

AG Series

Linkage-type adaptive grippers

Application field

The AG/DH series are able to applied with collabrative and industrial robots for loading, pick&place, assembly, inspection in machining, electronics, medical... etc. industries.

Features

Plug and Play

The linkage-type adaptive grippers support the Plug & Play with most brands of collabrative robot.

Parallel & adaptive gripping

The linkage-type adaptive grippers is able to grip round, spherical or heterosexual workpieces with the flexible fingers.

Integrated design

The drive controller and communication are integrated inside the gripper, and can be used without external controller.

Long stroke and adjustable gripping force

With 80mm stroke, the PGI-140 is compatible to grip objects with different size

Self-locking

The PGC series is able to maintain the gripping of the workpiece when the power is off, and improve the safety of the gripping process

Intelligent feedback

The AG/DH series is easy to monitor the gripping process according to the functions such as grasping status detection, real-time position detection and drop detection.



AG-160-95

Linkage-type adaptive gripper

DH-ROBOTICS

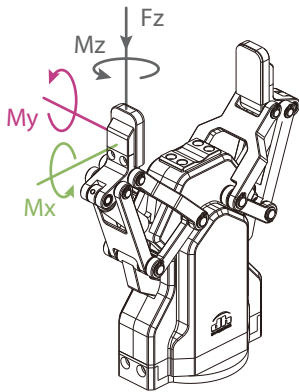

Allowable vertical load (static)

Fz: 300 N

Allowable vertical load (static)

Mx: 4.75 N·m

My: 4.75 N·m

Mz: 4.75 N·m

Gripping force

45~160 N

Stroke

95 mm

Mechanical specifications

Recommended workpiece weight* 3 kg

Repeat accuracy (positioning) ± 0.03 mm

Opening/closing time 0.7 s/0.7 s

Driving method Screw drive +Linkage system

Weight 1 kg

Noise emission < 50 dB

Electrical specifications

Communication Standard: Modbus RTU (RS485), Digital I/O interface Optional: TCP/IP, USB2.0, CAN2.0A,PROFINET,EtherCAT

Rated voltage 24 V DC ± 10%

Rated current 0.8 A

Peak current 1.5 A

IP class IP 54

Recommended environment 0~40°C, under 85% RH

*It depends on the shape of the grasping object, the material and friction of the contact surface, and the acceleration of the motion,if you have any questions, please contact us.

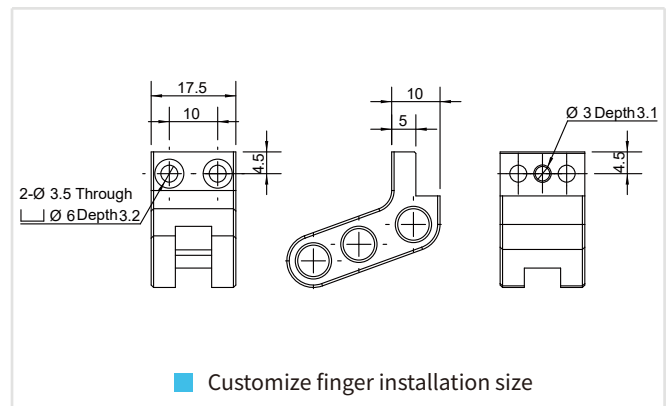
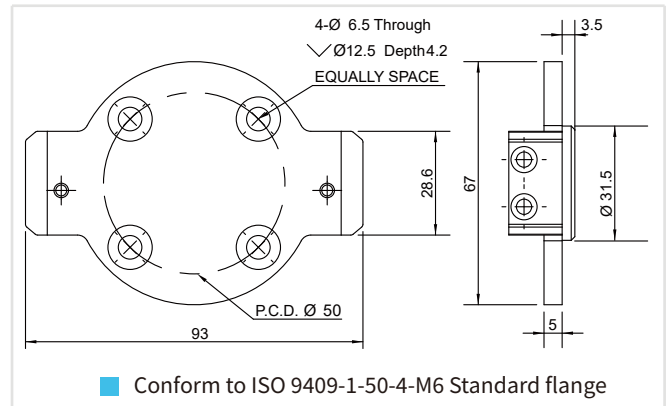
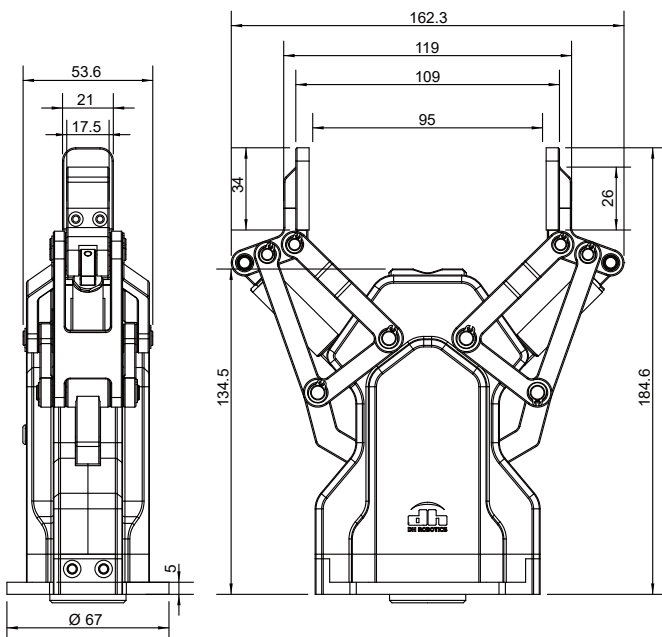

AG-105-145

DH-ROBOTICS

Linkage-type adaptive gripper

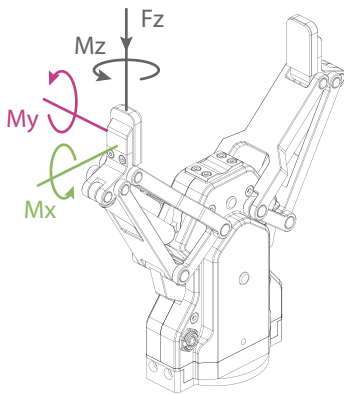

Allowable vertical load (static)

Fz: 300 N

Allowable vertical load (static)

Mx: 1.95 N·m

My: 1.95 N·m

Mz: 1.95 N·m

Gripping force

35~105 N

Stroke

145 mm

Mechanical specifications

Recommended workpiece weight* 2 kg

Repeat accuracy (positioning) ± 0.03 mm

Opening/closing time 0.7 s/0.7 s

Driving method Screw drive +Linkage system

Weight 1.3 kg

Noise emission < 50 dB

Electrical specifications

Communication Standard: Modbus RTU (RS485), Digital I/O interface Optional: TCP/IP, USB2.0, CAN2.0A,PROFINET,EtherCAT

Rated voltage 24 V DC ± 10%

Rated current 0.8 A

Peak current 1.5 A

IP class IP 54

Recommended environment 0~40°C, under 85% RH

*It depends on the shape of the grasping object, the material and friction of the contact surface, and the acceleration of the motion,If you have any questions, please contact us.

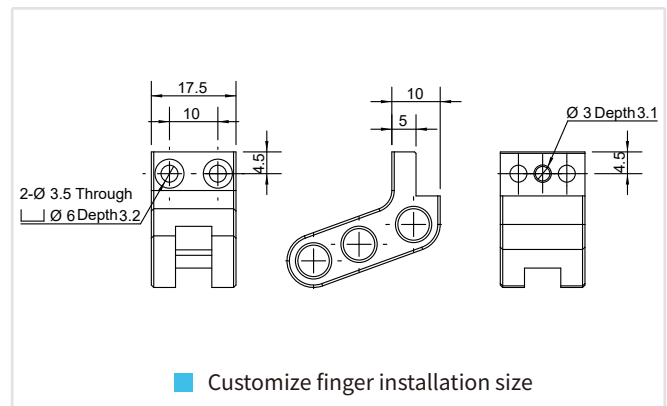
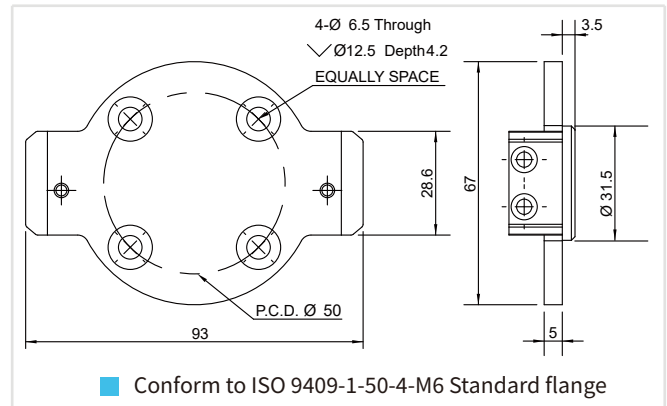
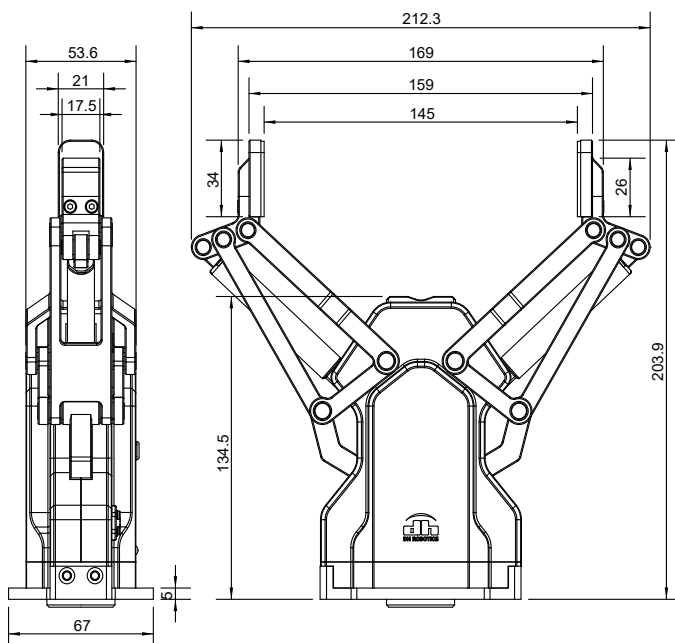

DH-3

Linkage-type adaptive gripper

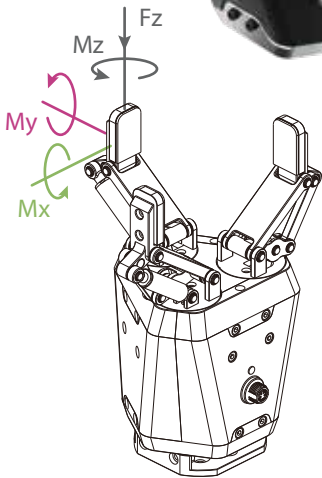

Allowable vertical load (static)

Fz: 150 N

Allowable vertical load (static)

Mx: 2.5 N·m

My: 2 N·m

Mz: 3 N·m

DH-ROBOTICS

Gripping force

Stroke

**10~65 N 106 mm (parallel)
122 mm (centric)**

Mechanical specifications

Recommended workpiece weight* 1.8 kg

Repeat accuracy (positioning) ± 0.03 mm

Opening/closing time 0.7 s/0.7 s

Driving method Screw, nut + gear drive + linkage mechanism

Weight 1.68 kg

Noise emission < 50 dB

Electrical specifications

Communication Standard: Modbus RTU (RS485), Digital I/O interface Optional: TCP/IP, USB2.0, CAN2.0A, PROFINET, EtherCAT

Rated voltage 24 V DC ± 10%

Rated current 0.5 A

Peak current 1 A

Recommended environment 0~40°C, under 85% RH

*It depends on the shape of the grasping object, the material and friction of the contact surface, and the acceleration of the motion, if you have any questions, please contact us.

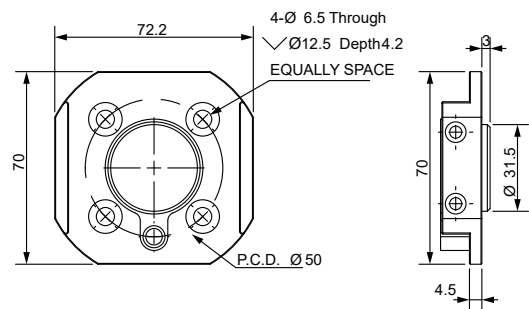
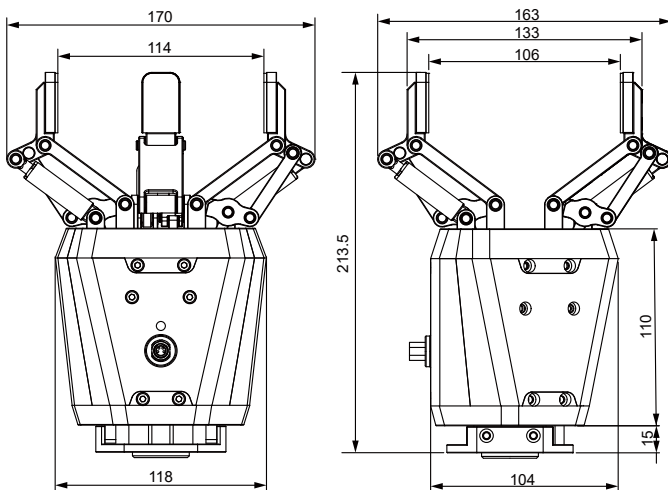

Conform to ISO 9409-1-50-4-M6 Standard flange

