

DH-ROBOTICS

SERVO ELECTRIC CYLINDER

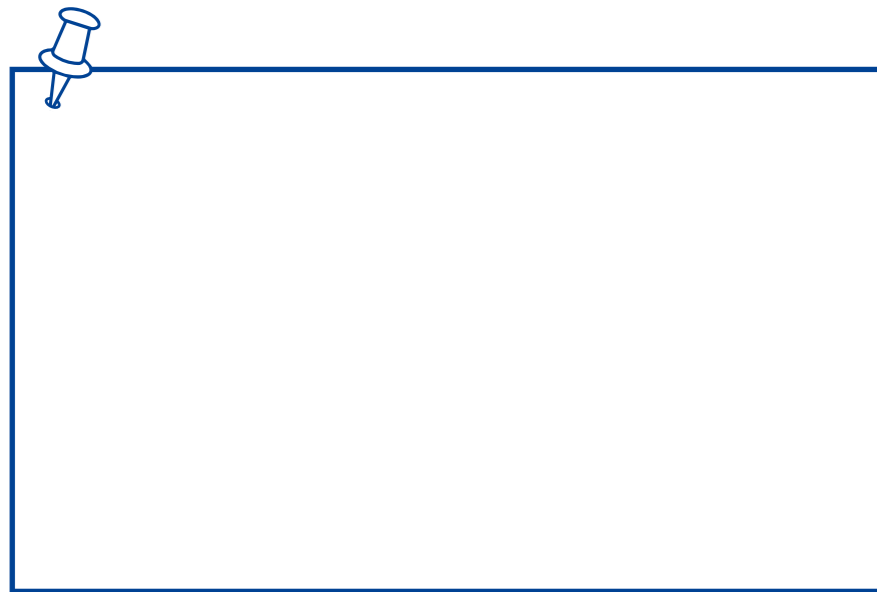

DH-Robotics Technology Co.,Ltd.

Linked in | **YouTube** Search DH-Robotics

EN-3.3.2023.11

en.dh-robotics.com

info@dh-robotics.com

14th Floor, Building A4, Nanshan Intelligence Park, No. 1001 Xueyuan Avenue, Taoyuan Street,
Nanshan District, Shenzhen City, Guangdong Province, China.

MCE Series

The MCE series is miniature linear stage cylinder features high energy density, large load capacity, and a compact and exquisite design. It is suitable for various applications, enabling the completion of complex tasks such as handling arranging, and transporting.

High Energy Density

Small size, high energy, high rigidity, with a maximum horizontal load capacity of **15kg**.

Compact Design

Compact overall structure with a width of only **35mm**, allowing for sensitive.

Fast and Precise

Equipped with a high-performance servo motor and precision grinding screw, achieving a maximum speed of up to **330mm/s**. The repeated positioning accuracy reaches **±0.003 mm**.

Programmable parameters, a variety of motion modes

The position, speed, and thrust parameters are programmable to implement essential functions of pushing, pulling, pressing, and positioning at high speed. Either the position mode or pushing & pressing mode is available.



Position mode



Pushing & pressing mode

Preferred applications



Application



MCE-4G



MCE-3WG



MCE-3G

LCE Series

The LCE series adopts an embedded rail structure, integrating a ball screw and servo motor for outstanding characteristics of long travel, high rigidity, and high precision. Widely applied in automation tasks such as positioning, picking, and handling, it provides users with a reliable and efficient solution.

Compact Precision Design

Featuring a compact and precision-engineered structure, our motor and rail integrated design significantly reduces dimensions. With a minimum width of just **35 mm**, it surpasses similar products in volume even under equivalent load conditions.

Strong Rigidity, High Load Capacity

With adjustable parameters for thrust, position, and speed, our system boasts robust rigidity and large load capacity. It seamlessly integrates with fixtures or related mechanisms to accomplish intricate tasks such as handling, arrangement, and transport, ensuring stable and outstanding load performance.

High Precision, High Speed

Equipped with a precision lead screw, the product achieves remarkable repeatability positioning accuracy of $\pm 0.02\text{mm}$. It attains impressive speeds, with a maximum velocity of up to **1000mm/s** (for a 20mm lead), and accelerates up to **5000mm/s²**.

Compact Size, Flexible Installation

Compared to conventional assemblies, our product reduces width dimensions by **30%** under the same load, resulting in a compact size and flexible installation.

Application

3C Electronics

New Energy

Automotive

Mechanical Processing



Advantages of Electric Cylinder over Pneumatic Cylinder

Flexibly adjustable position, force, and speed

	Electric cylinder	Pneumatic cylinder
Position	<ol style="list-style-type: none"> Multi-location programming The accuracy is determined by the software with positioning repeatability accurate to ± 0.02 mm 	<ol style="list-style-type: none"> A magnetic switch and a mechanically controlled valve are used to achieve positioning The accuracy is determined by the stopper and installation method
Force	<ol style="list-style-type: none"> Controllable and programmable Capable of approaching at high speed and pressing & pushing at low speed 	<ol style="list-style-type: none"> The pressure of the air channel shall be adjusted in each adjustment The speed is coupled with force. To apply high thrust at low speed, an air-liquid converter shall be activated
Speed	<ol style="list-style-type: none"> Multi-section acceleration and uniform motion The max. speed can reach nearly 1000 mm/s by the use of a large-lead screw 	<ol style="list-style-type: none"> Large speed fluctuation Delayed action The speed of standard pneumatic cylinders mostly ranges from 50 to 500 mm/s

Speed of electric cylinder

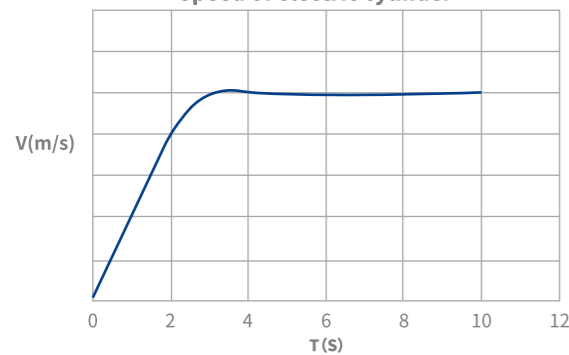

The speed and thrust of the electric cylinder are more stable and smooth

Speed of pneumatic cylinder

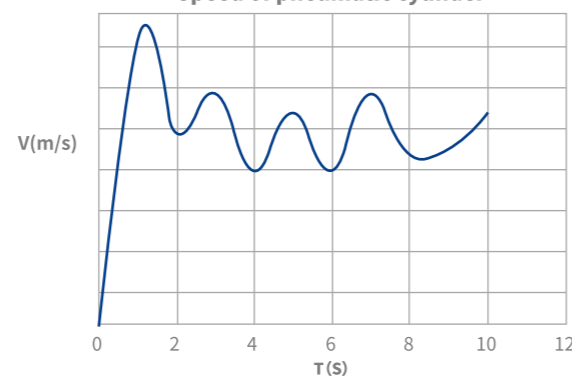

A pneumatic cylinder is compressible, resulting in poor motion stability and slow start

Plug and play

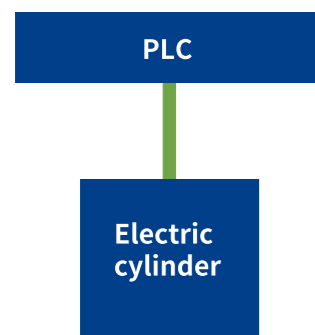

Connection diagram of electric cylinder

A controller is optional for the electric cylinder and can work simply by connecting with the PLC. Position information is returned in real time, and no external photoelectric switch is required.

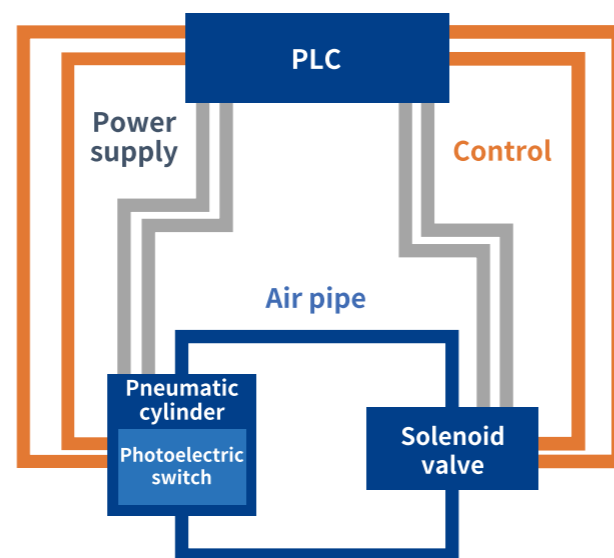

Connection diagram of pneumatic cylinder

Advantages of Servo Electric Cylinder over Stepper Electric Cylinder

Better thrust and load

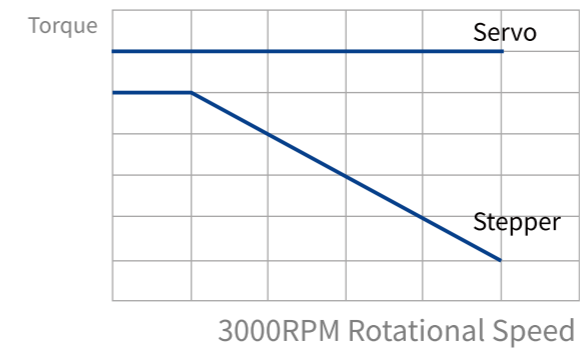

Stepper motor is limited by principle of the motor, high speed and strong force can no be met at the same time. Above 1000 RPM speed, the output torque drops sharply. At 3000 RPM speed (servo motor standard speed), the output torque of the servo motor will only be left a third or less. The output torque of the servo motor remains the same within the rated speed range, while the maximum speed and maximum torque of the stepper motor can not be achieved at the same time.

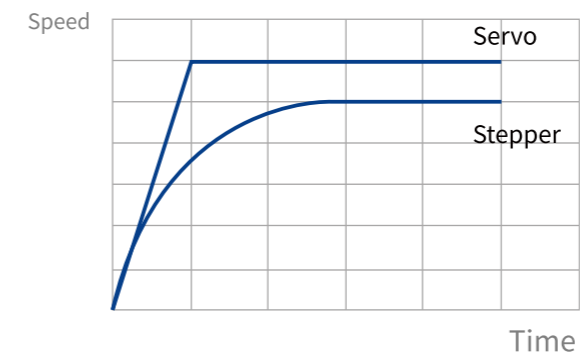

Closed-loop stepper motors have a speed limit of 3000 RPM speed, while servo motors can reach 6000 RPM speed or higher. Since stepper motors have the characteristic of decreasing torque as speed increases, the acceleration also decreases sharply as the speed increases, resulting in a longer acceleration section, making the working beat duration increase.

Applications

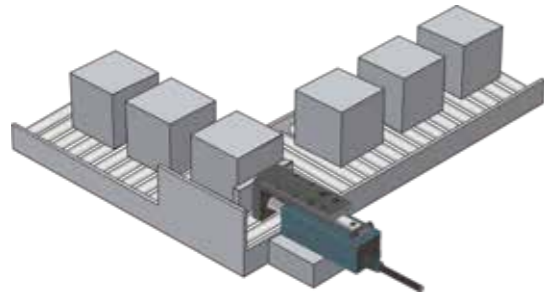

Pushing and conveying

The electric cylinder pushes the workpiece on the conveyor belt in the production line to another conveyor belt at a specific angle in place of repetitive manual operation to achieve automated production.

Advantages

The MCE series electric cylinder runs at high speed to significantly improve productivity. The thrust is adjustable up to 200 N to meet workpiece handling requirements at different weight levels. In addition, the acceleration can be programmed, enabling effective prevention of damage to workpieces, improved productivity, and reduced labour cost.

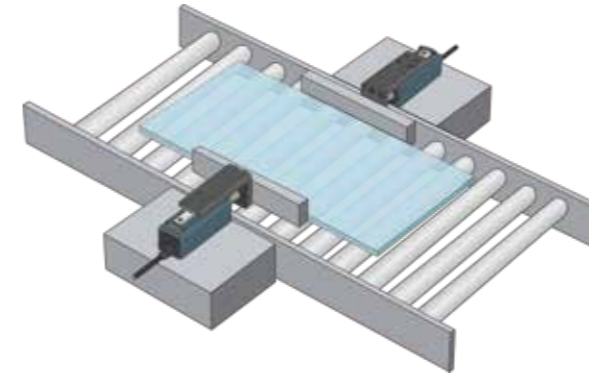

Positioning correction

The use of an electric cylinder for positioning solves the problem of large positioning error and difficult commissioning in a pneumatic cylinder. The thrust is adjustable so that damage to workpiece may be avoided. For example glass substrate positioning and panel positioning devices are used.

Advantages

The MCE series electric cylinder has the positioning repeatability of ± 0.02 mm and can perform well for accurate positioning at high speed.

Pressure loading

The MCE miniature electric cylinder pushes a heavy workpiece into the punching machine in place of manual handling, which reduces the risk of accident and improves productivity.

Advantages

The MCE series electric cylinder has excellent load capacity, with a maximum weight capacity of 15 kg in the horizontal direction. The parameters are adjustable for accurate speed governing and positioning to ensure the machining accuracy of workpiece.

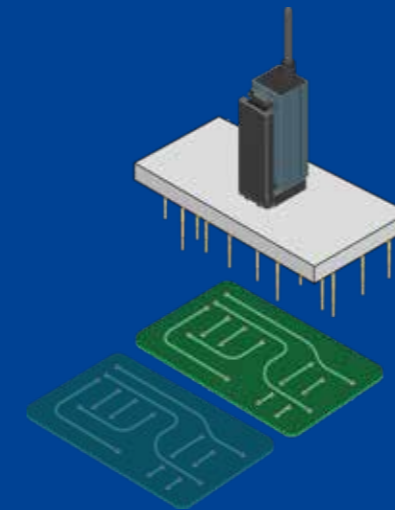
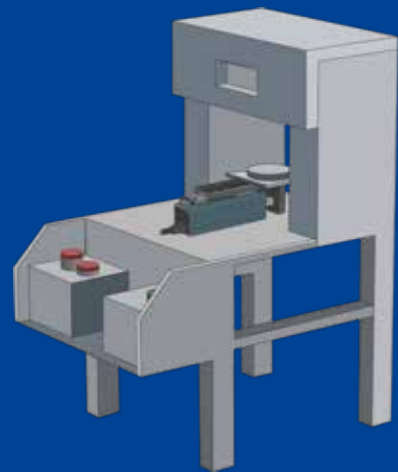

Detection

The MCE miniature electric cylinder is used to lift and lower the probes to test the conduction performance of the circuit board. The MCE miniature electric cylinder can perform well to allow multiple probes to work at a time.

Advantages

The MCE parameters are adjustable, and the position, speed, and thrust can be accurately programmed to achieve soft landing and pushing & pressing of workpieces. The MCE performs well in meeting the flexible production requirements in 3C electronics industry.

Pushing & pressing

The MCE miniature electric cylinder is used instead of conventional servo + sensor system to push and press mount components into the base in the component mounting process.

Advantages

The MCE can be programmed to achieve soft landing and pushing & pressing of workpieces at low speed after approaching the workpieces at high speed, speeding up the cycle time while reducing the defect rate and production costs.

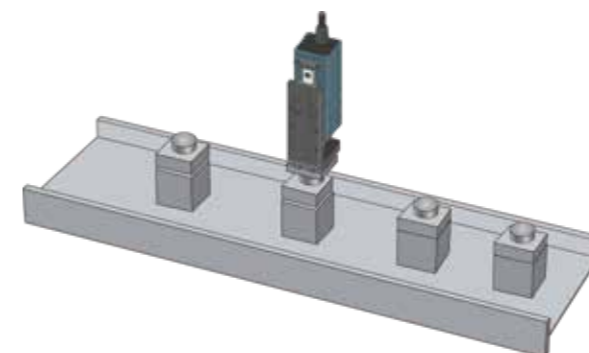
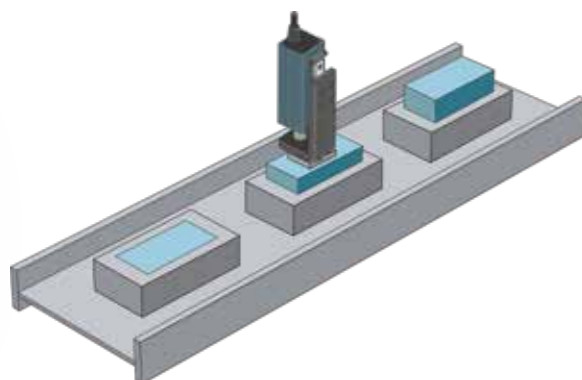

Installation

The MCE miniature electric cylinder is used to press fit the cover of the electronic component onto the component body. The position, speed, and thrust of the electric cylinder can be governed to complete operation tasks more efficiently and stably.

Advantages

The position, speed, and thrust parameters of the MCE can be programmed to achieve soft landing and pushing & pressing of workpieces, meeting the flexible production requirements in 3C electronics industry while reducing the defect rate and downtime.

MCE-3G

MINIATURE ELECTRIC TABLE TYPE CYLINDER

SELECTION METHOD

Cylinder Series	Width	Guide Type	Lead(mm)/Screw Type	Stroke (mm)	Integrated or not	Brake	Cable Mounting Direction	Cable Length	Customized*
MCE	3 G	01 □	030	C	O	B	L1	0	
	G Guide WG Wide guide	01 02 04 06 None Ball screw P Grinding screw rod	030 050 C Integrated driver E Non-integrated driver	O Without brake W With brake	B Backward F Forward	L1 1m L3 3m L5 5m L10 10m	0 No customization 1 Customization		



Horizontal mounting



Horizontal mounting on side

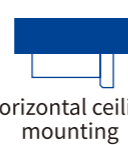

Horizontal ceiling mounting



Vertical mounting

*Note: For customization fees, consult with the sales staff of DH-Robotics

TECHNICAL SPECIFICATIONS

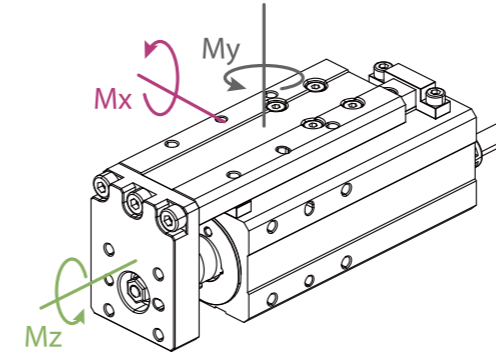

Technical Parameters				
Total stroke(mm)	30, 50			
Screw lead(mm)	1	2	4	6
Rated thrust(N)	200	100	50	30
Min. thrust(N)	60	30	15	9
Max. speed(mm/s)	50	100	200	300
Max. acceleration(mm/s ²)	2000	3000	3000	3000
Max. weight capacity - horizontal(kg)	8	6	3	2
Max. weight capacity - vertical(kg)	2	1.5	0.75	0.5
Positioning repeatability(mm)	±0.02 ±0.003(Grinding screw rod)			
Idle stroke(mm)	Below 0.1 mm			

Operating Environment	
Communication protocol	Built-in: 485+4-way I/O(NPN, PNP) External: Depending on the selected driver
Adaptable to external driver	SAC Serie
Rated voltage	24 V DC ± 10%
Current	1.5 A(Rated)/3 A(Peak)
Protection rating	IP 40
Recommended operating environment	0 to 40°C, below 85% RH
Compliance with international standards	CE, FCC, RoHS

Allowable load moment	
Mx	9.9 N·m
My	9.9 N·m
Mz	3.3 N·m

Stroke	30 mm	50 mm
Width	35 mm	35 mm
Weight	0.47 kg	0.55 kg

Dimensions

Note:
1.A and B are additional hole distances for a 50-stroke, where A is the distance for locating pins and B is the distance for M4 mounting holes. For a 30-stroke, there are no additional hole distances, so both A and B for 30-stroke are 0.
2.Dotted line dimensions on the drawing are tail end forward.

Caution:
When resetting the origin, the slider will continuously move to ME (mechanical end), so please be careful not to interfere with surrounding objects.

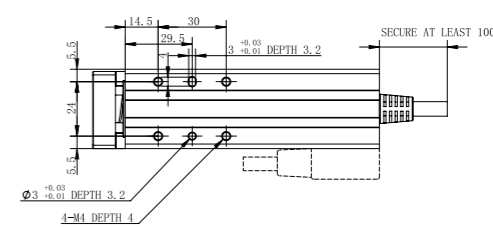
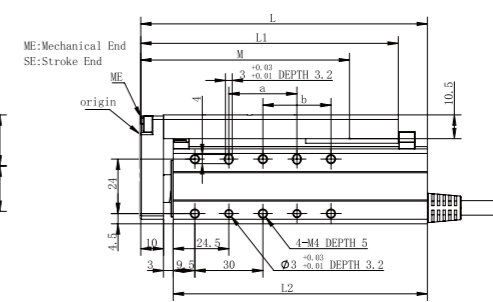
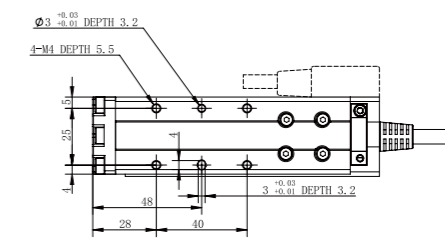
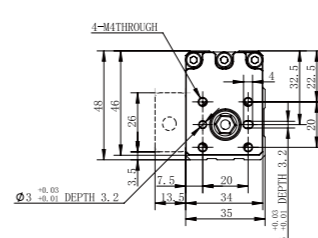

	mm	
Stroke	30	50
L	105	125
L1	93.5	113.5
L2	92	112
L2 (With brake)	112	132
M	72	92
a	0	30
b	0	30

MCE-3WG

MINIATURE ELECTRIC TABLE TYPE CYLINDER

SELECTION METHOD

Cylinder Series	Width	Guide Type	Lead(mm)/Screw Type	Stroke (mm)	Integrated or not	Brake	Cable Mounting Direction	Cable Length	Customized*
MCE	3 WG	01 <input type="checkbox"/>	030	C	O	B	L1	0	
	G Guide WG Wide guide	01 02 04 06 None Ball screw P Grinding screw rod	030 050 C Integrated driver E Non-integrated driver	O Without brake W With brake	B Backward F Forward	L1 1m L3 3m L5 5m L10 10m	0 No customization 1 Customization		





Horizontal mounting



Horizontal ceiling mounting



Vertical mounting

*Note: For customization fees, consult with the sales staff of DH-Robotics

TECHNICAL SPECIFICATIONS

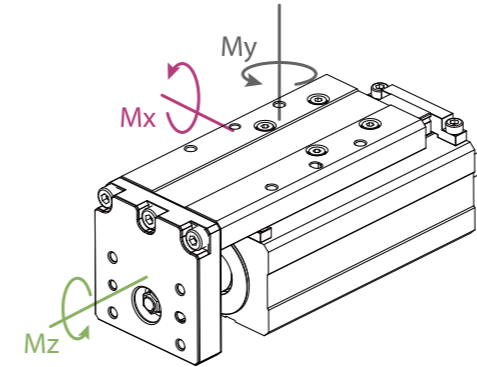

Technical Parameters

Total stroke(mm)	30, 50			
Screw lead(mm)	1	2	4	6
Rated thrust(N)	200	100	50	30
Min. thrust(N)	60	30	15	9
Max. speed(mm/s)	50	100	200	300
Max. acceleration(mm/s ²)	2000	3000	3000	3000
Max. weight capacity - horizontal(kg)	8	6	3	2
Max. weight capacity - vertical(kg)	2	1.5	0.75	0.5
Positioning repeatability(mm)	±0.02 ±0.003(Grinding screw rod)			
Idle stroke(mm)	Below 0.1 mm			

Operating Environment

Communication protocol	Built-in: 485+4-way I/O(NPN, PNP) External: Depending on the selected driver
Adaptable to external driver	SAC Serie
Rated voltage	24 V DC ± 10%
Current	1.5 A(Rated)/3 A(Peak)
Protection rating	IP 40
Recommended operating environment	0 to 40°C, below 85% RH
Compliance with international standards	CE, FCC, RoHS

Allowable load moment

Mx	9.9 N·m
My	9.9 N·m
Mz*	12.2 N·m

*The MCE-3WG uses a more functional wide guide to provide a higher eccentric load moment, when compared with MCE-3G

Stroke

	30 mm	50 mm
Width	46 mm	46 mm
Weight	0.62 kg	0.7 kg

Dimensions

Note:

- M: Allows for the permissible load eccentricity distance.
- Dotted lines in the drawing indicate hole dimensions for installation when the stroke is 30mm.
- Dotted lines in the drawing indicate the dimensions of the tail when the feature faces forward in the direction of exit.

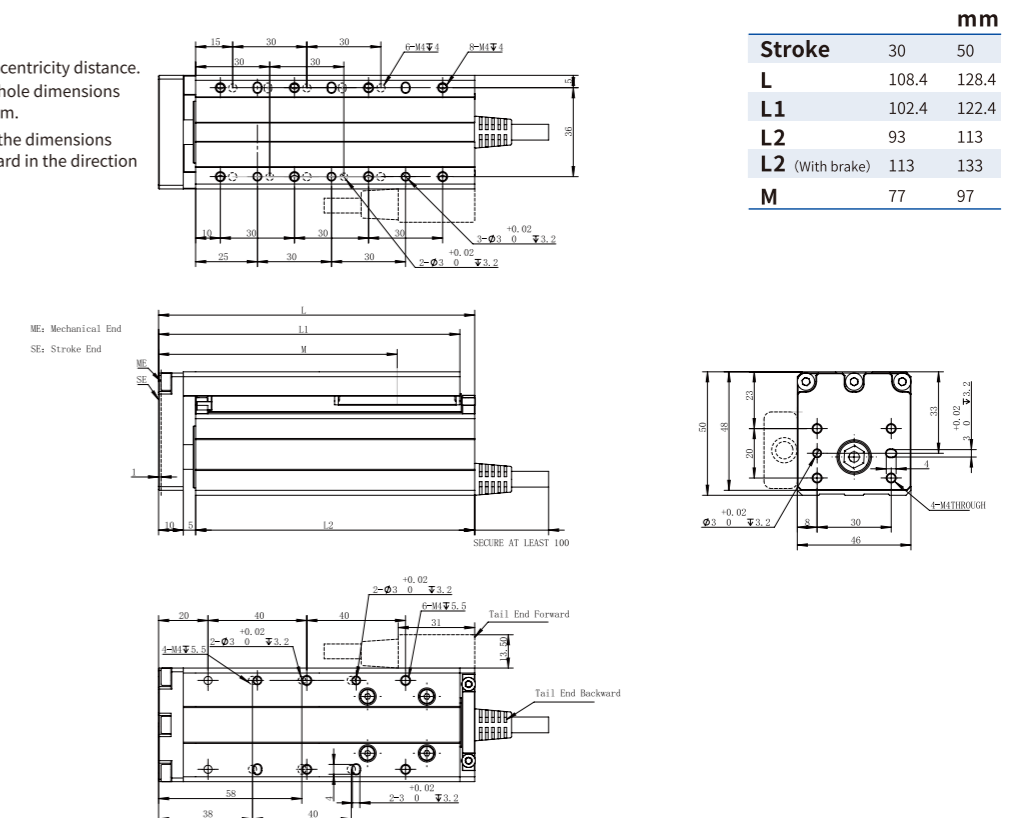

MCE-4G

MINIATURE ELECTRIC TABLE TYPE CYLINDER

SELECTION METHOD

Cylinder Series	Width	Guide Type	Lead(mm)/Screw Type	Stroke (mm)	Integrated or not	Brake	Cable Mounting Direction	Cable Length	Customized*
MCE	4 G	05 □	075	E	O	B	L1	0	
	G Guide	05 10	075 150	None Ball screw P Grinding screw rod	E Non-integrated driver	O Without brake W With brake	B Backward F Forward	L1 1m L3 3m L5 5m L10 10m	0 No customization 1 Customization

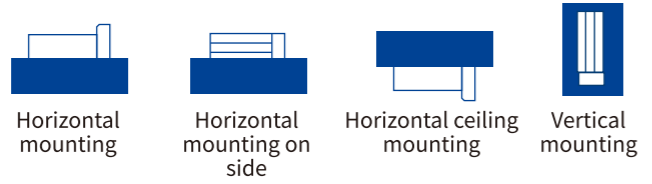
TECHNICAL SPECIFICATIONS

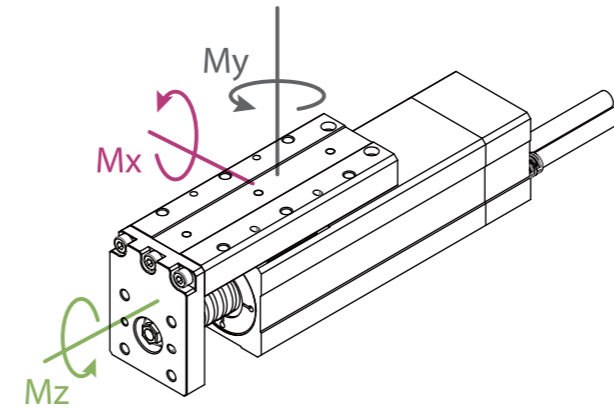

Technical Parameters

Total stroke(mm)	75, 150
Screw lead(mm)	5 10
Rated thrust(N)	170 85
Min. thrust(N)	51 25.5
Max. acceleration(mm/s ²)	2000 3000
Max. speed(mm/s)	165 330
Max. weight capacity - horizontal(kg)	15 15
Max. weight capacity - vertical(kg)	6 3
Positioning repeatability(mm)	±0.02 ±0.003(Grinding screw rod)
Idle stroke(mm)	Below 0.1 mm

Operating Environment

Communication protocol	External: Depending on the selected driver
Adaptable to external driver	SAC Serie
Rated voltage	24 V DC ± 10%
Current	2.5 A(Rated)/7 A(Peak)
Protection rating	IP 40
Recommended operating environment	0 to 40°C, below 85% RH
Compliance with international standards	CE, FCC, RoHS

Allowable load moment

Mx	18.8 N·m
My	18.8 N·m
Mz	30.5 N·m

Mechanical Parameters

Stroke	75 mm	150 mm
Width	43.5 mm	43.5 mm
Weight	1.4 kg	1.65 kg

Dimensions

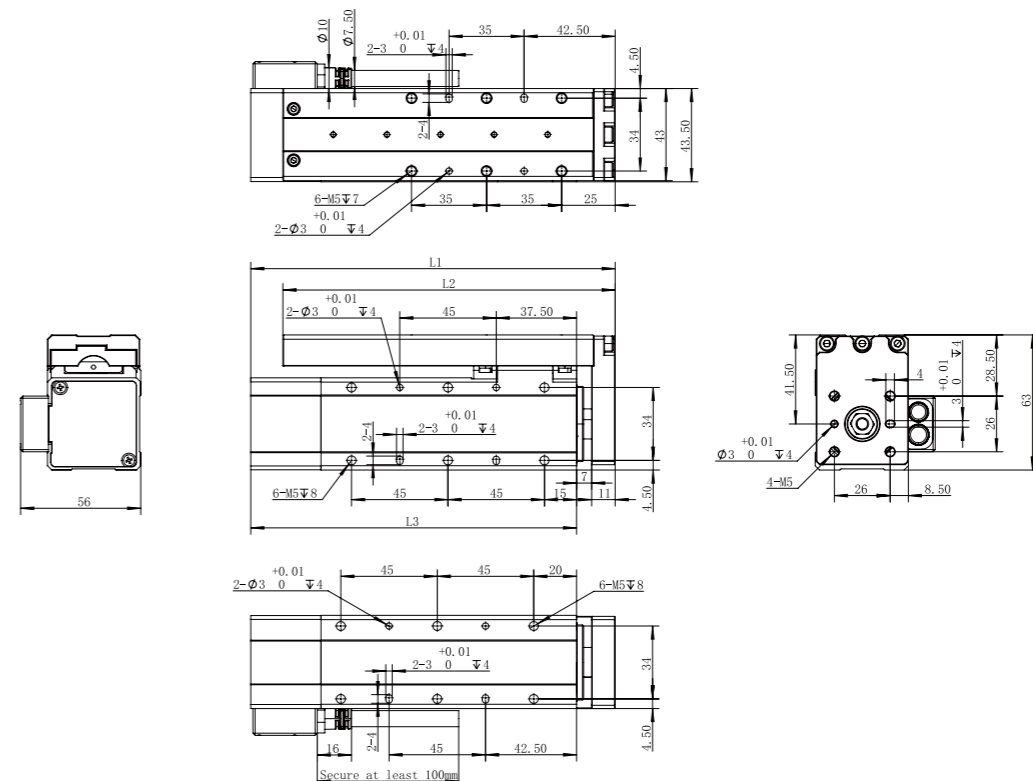

Without Brake mm

Stroke	75	150
L1	170	235
L2	155	235
L3	152	217

With Brake mm

Stroke	75	150
L1	185	235
L2	160	235
L3	167	217

*Note: For customization fees, consult with the sales staff of DH-Robotics

LCE-4

LINEAR ELECTRIC CYLINDER

SELECTION METHOD

Cylinder Series	Width	Guide Type	Lead (mm)	Stroke (mm)	Integrated or not	Brake	Cable Mounting Direction	Cable Length	Customized**																															
LCE	4 C		02	100	E	O	B	L1	0																															
	<table border="1"> <tr><td>4C</td><td>Motor Hidden in</td></tr> <tr><td>4ML</td><td>Motor Left Side</td></tr> <tr><td>4MR</td><td>Motor Right Side</td></tr> <tr><td>4MB</td><td>Motor Bottom Side</td></tr> </table>	4C	Motor Hidden in	4ML	Motor Left Side	4MR	Motor Right Side	4MB	Motor Bottom Side		<table border="1"> <tr><td>02</td></tr> <tr><td>05</td></tr> <tr><td>10</td></tr> </table>	02	05	10	100~500mm(50mm pitch)	E Non-integrated driver	<table border="1"> <tr><td>O</td><td>Without brake</td></tr> <tr><td>W</td><td>With brake</td></tr> </table>	O	Without brake	W	With brake	<table border="1"> <tr><td>B</td><td>Backward^①</td></tr> <tr><td>F</td><td>Forward</td></tr> </table>	B	Backward ^①	F	Forward	<table border="1"> <tr><td>L1</td><td>1m</td></tr> <tr><td>L3</td><td>3m</td></tr> <tr><td>L5</td><td>5m</td></tr> <tr><td>L10</td><td>10m</td></tr> </table>	L1	1m	L3	3m	L5	5m	L10	10m	<table border="1"> <tr><td>0</td><td>No customization</td></tr> <tr><td>1</td><td>Customization</td></tr> </table>	0	No customization	1	Customization
4C	Motor Hidden in																																							
4ML	Motor Left Side																																							
4MR	Motor Right Side																																							
4MB	Motor Bottom Side																																							
02																																								
05																																								
10																																								
O	Without brake																																							
W	With brake																																							
B	Backward ^①																																							
F	Forward																																							
L1	1m																																							
L3	3m																																							
L5	5m																																							
L10	10m																																							
0	No customization																																							
1	Customization																																							

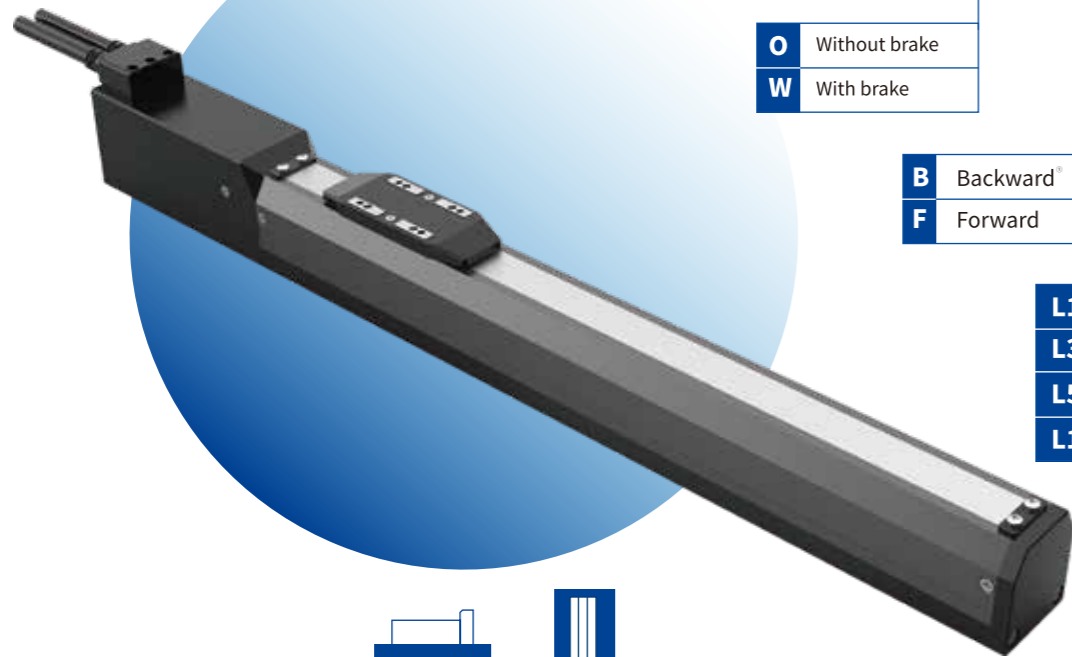

TECHNICAL SPECIFICATIONS

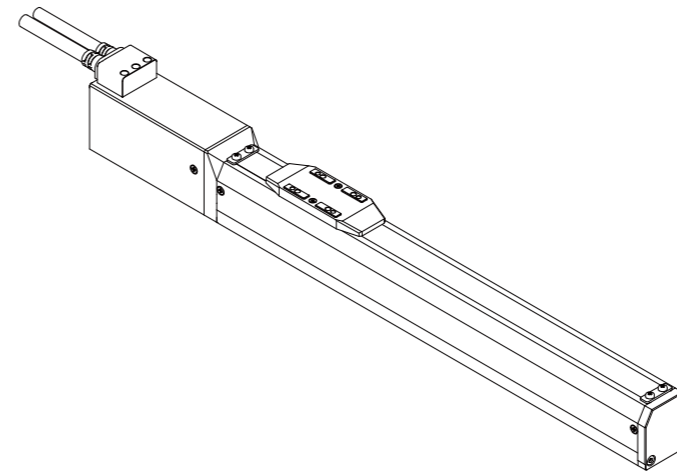

Technical Parameters			
Total stroke	100~500mm(50mm pitch)		
Screw lead	2 mm	5 mm	10 mm
Rated thrust	125 N	50 N	25 N
Min. thrust	37.5 N	15 N	7.5 N
Max. acceleration	5000 mm/s ²	5000 mm/s ²	5000 mm/s ²
Max. speed	100 mm/s	250 mm/s	500 mm/s
Max. weight capacity - horizontal	15 kg	15 kg	12 kg
Max. weight capacity - vertical	6 kg	3 kg	1.5 kg
Positioning repeatability	±0.02 mm		
Idle stroke	Below 0.1 mm		
Operating Environment			
Communication protocol	External: Depending on the selected driver		
Adaptable to external driver	SAC Serie		
Rated voltage	24 V DC ± 10%		
Current	1.5 A(Rated)/3 A(Peak)		
Protection rating	IP 40		
Recommended operating environment	0 to 40°C, below 85% RH		
Compliance with international standards	CE, FCC, RoHS		
Allowable load moment			
Mx	36.4 N·m		
My	42.3 N·m		
Mz	14.33 N·m		

*Note: ① LCE-4ML/MR/MB no tail end backward option
 ② For customization fees, consult with the sales staff of DH-Robotics

LCE-4C Dimensions

Motor Hidden in

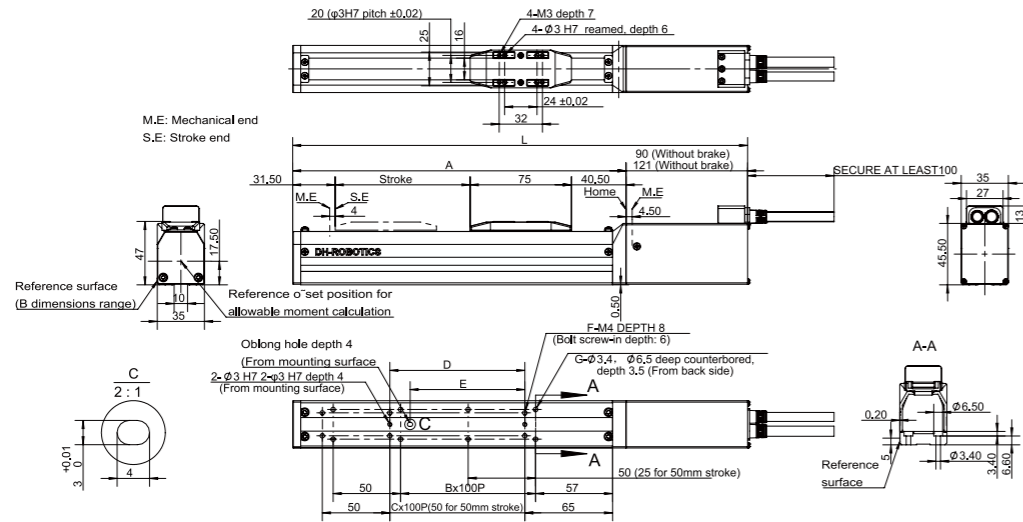

Stroke	100	150	200	250	300	350	400	450	500	
L	w/o brake	337	387	437	487	537	587	637	687	737
	w/ brake	367	417	467	517	567	617	667	717	767
A	247	297	347	397	447	497	547	597	647	
B	0	1	1	2	2	3	3	4	4	
C	1	1	2	2	3	3	4	4	5	
D	100	100	200	200	300	300	400	400	500	
E	85	85	185	185	285	285	385	385	485	
F	6	6	8	8	10	10	12	12	14	
G	8	10	10	12	12	14	14	16	16	
Mass (kg)	w/o brake	1.4	1.5	1.6	1.7	1.8	1.9	2.0	2.1	2.2
	w/ brake	1.6	1.7	1.8	1.9	2.0	2.1	2.2	2.3	2.4

LCE-4MR Dimensions

Motor Right Side

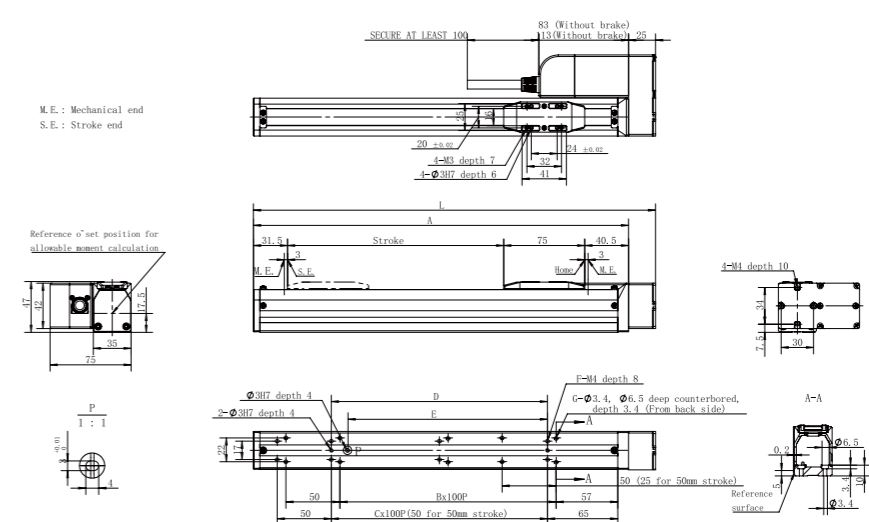

Stroke	100	150	200	250	300	350	400	450	500	
L	272	322	372	422	472	522	572	622	672	
A	247	297	347	397	447	497	547	597	647	
B	0	1	1	2	2	3	3	4	4	
C	1	1	2	2	3	3	4	4	5	
D	100	100	200	200	300	300	400	400	500	
E	85	85	185	185	285	285	385	385	485	
F	6	6	8	8	10	10	12	12	14	
G	8	10	10	12	12	14	14	16	16	
Mass (kg)	w/o brake	1.3	1.4	1.5	1.6	1.7	1.8	1.9	2	2.1
	w/ brake	1.5	1.6	1.7	1.8	1.9	2	2.1	2.2	2.3

LCE-4ML Dimensions

Motor Left Side

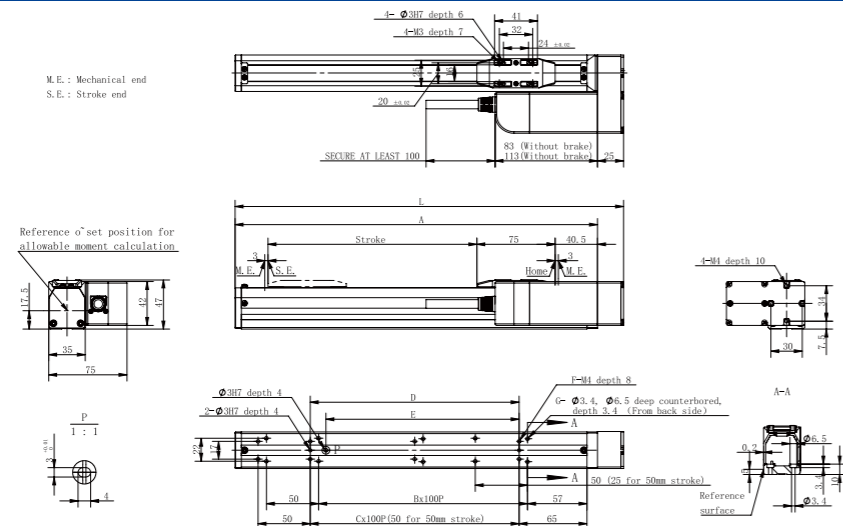

Stroke	100	150	200	250	300	350	400	450	500	
L	272	322	372	422	472	522	572	622	672	
A	247	297	347	397	447	497	547	597	647	
B	0	1	1	2	2	3	3	4	4	
C	1	1	2	2	3	3	4	4	5	
D	100	100	200	200	300	300	400	400	500	
E	85	85	185	185	285	285	385	385	485	
F	6	6	8	8	10	10	12	12	14	
G	8	10	10	12	12	14	14	16	16	
Mass (kg)	w/o brake	1.3	1.4	1.5	1.6	1.7	1.8	1.9	2	2.1
	w/ brake	1.5	1.6	1.7	1.8	1.9	2	2.1	2.2	2.3

LCE-4MB Dimensions

Motor Bottom Side

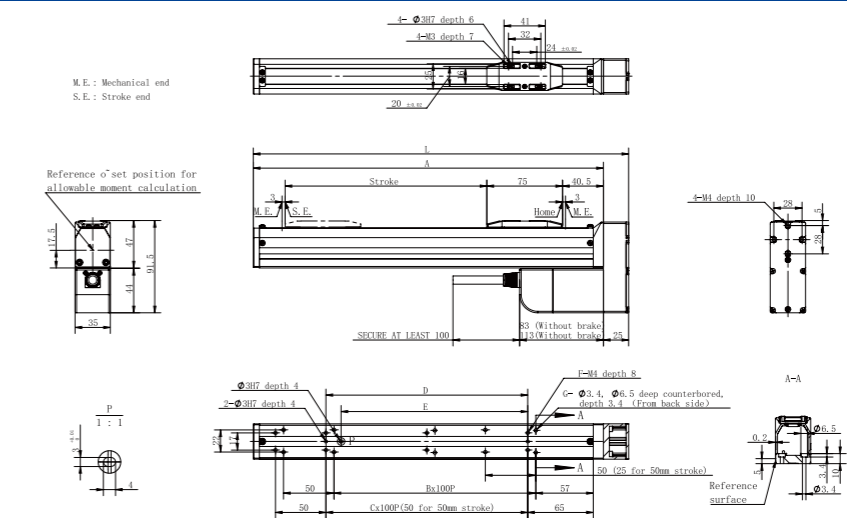

Stroke	100	150	200	250	300	350	400	450	500	
L	272	322	372	422	472	522	572	622	672	
A	247	297	347	397	447	497	547	597	647	
B	0	1	1	2	2	3	3	4	4	
C	1	1	2	2	3	3	4	4	5	
D	100	100	200	200	300	300	400	400	500	
E	85	85	185	185	285	285	385	385	485	
F	6	6	8	8	10	10	12	12	14	
G	8	10	10	12	12	14	14	16	16	
Mass (kg)	w/o brake	1.3	1.4	1.5	1.6	1.7	1.8	1.9	2	2.1
	w/ brake	1.5	1.6	1.7	1.8	1.9	2	2.1	2.2	2.3

LCE-5

LINEAR ELECTRIC CYLINDER

SELECTION METHOD

Cylinder Series	Width	Guide Type	Lead (mm)	Stroke (mm)	Integrated or not	Brake	Cable Mounting Direction	Cable Length	Customized**																															
LCE	5 C		05	100	E	O	B	L1	0																															
	<table border="1"> <tr><td>5C</td><td>Motor Hidden in</td></tr> <tr><td>5ML</td><td>Motor Left Side</td></tr> <tr><td>5MR</td><td>Motor Right Side</td></tr> <tr><td>5MB</td><td>Motor Bottom Side</td></tr> </table>	5C	Motor Hidden in	5ML	Motor Left Side	5MR	Motor Right Side	5MB	Motor Bottom Side		<table border="1"> <tr><td>05</td></tr> <tr><td>10</td></tr> <tr><td>20</td></tr> </table>	05	10	20	100~800mm(50 mm pitch)	E Non-integrated driver	<table border="1"> <tr><td>O</td><td>Without brake</td></tr> <tr><td>W</td><td>With brake</td></tr> </table>	O	Without brake	W	With brake	<table border="1"> <tr><td>B</td><td>Backward*</td></tr> <tr><td>F</td><td>Forward</td></tr> </table>	B	Backward*	F	Forward	<table border="1"> <tr><td>L1</td><td>1m</td></tr> <tr><td>L3</td><td>3m</td></tr> <tr><td>L5</td><td>5m</td></tr> <tr><td>L10</td><td>10m</td></tr> </table>	L1	1m	L3	3m	L5	5m	L10	10m	<table border="1"> <tr><td>0</td><td>No customization</td></tr> <tr><td>1</td><td>Customization</td></tr> </table>	0	No customization	1	Customization
5C	Motor Hidden in																																							
5ML	Motor Left Side																																							
5MR	Motor Right Side																																							
5MB	Motor Bottom Side																																							
05																																								
10																																								
20																																								
O	Without brake																																							
W	With brake																																							
B	Backward*																																							
F	Forward																																							
L1	1m																																							
L3	3m																																							
L5	5m																																							
L10	10m																																							
0	No customization																																							
1	Customization																																							

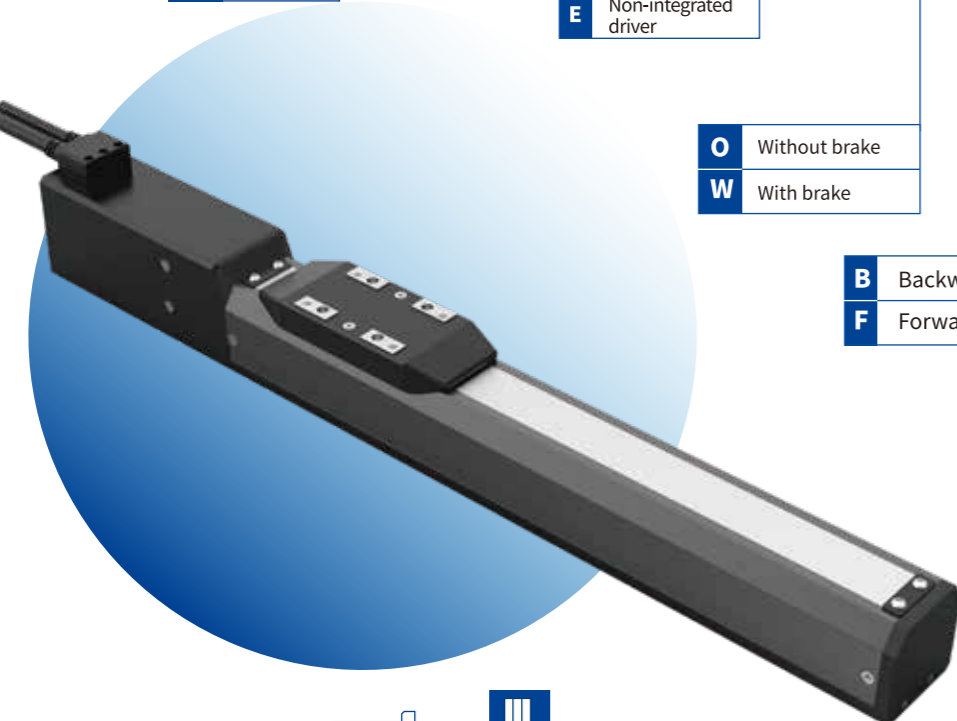



Horizontal mounting



Vertical mounting

TECHNICAL SPECIFICATIONS

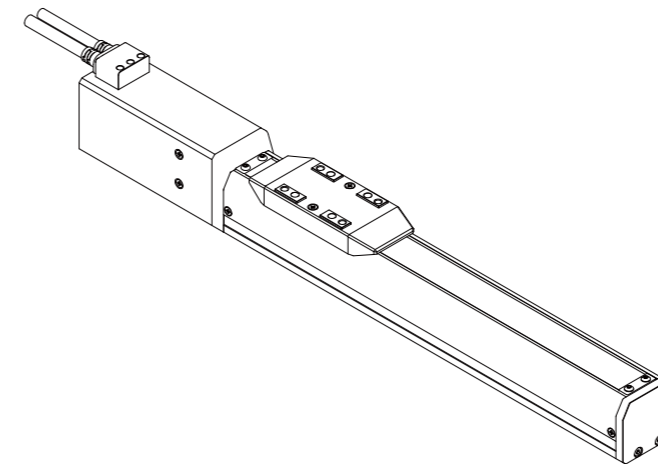

Technical Parameters

Total stroke	100~800mm(50 mm pitch)		
Screw lead	5 mm	10 mm	20 mm
Rated thrust	320 N	160 N	80 N
Min. thrust	96 N	48 N	24 N
Max. acceleration	5000 mm/s ²	5000 mm/s ²	5000 mm/s ²
Max. speed	250 mm/s	500 mm/s	1000 mm/s
Max. weight capacity - horizontal	35 kg	25 kg	15 kg
Max. weight capacity - vertical	10 kg	5 kg	2.5 kg
Positioning repeatability	±0.02 mm		
Idle stroke	Below 0.1 mm		

Operating Environment

Communication protocol	Standard configurations: Modbus RTU (RS485), Digital I/O Option: EtherCAT Need to adapt to the external purchase of other brands of drives
Rated voltage	24 V DC ± 10%
Rated power	100 W
Protection rating	IP 40
Recommended operating environment	0 to 40°C, below 85% RH
Compliance with international standards	CE, FCC, RoHS

Allowable load moment

Mx	78.6 N·m
My	91.0 N·m
Mz	31.5 N·m

*Note: ① LCE-5ML/MR/MB no tail end backward option
② For customization fees, consult with the sales staff of DH-Robotics

LCE-5C Dimensions

Motor Hidden in

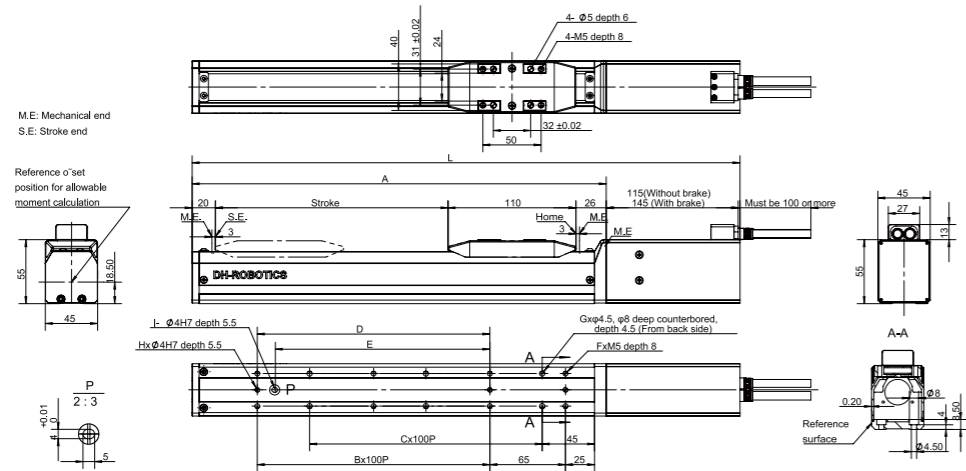

Stroke	100	150	200	250	300	350	400	450	500	550	600	650	700	750	800
	L	371	421	471	521	571	621	671	721	771	821	871	921	971	1021
A	256	306	356	406	456	506	556	606	656	706	756	806	856	906	956
B	1	1	2	2	3	3	4	4	5	5	6	6	7	7	8
C	1	2	2	3	3	4	4	5	5	6	6	7	7	8	8
D	100	100	200	200	300	300	400	400	500	500	600	600	700	700	800
E	85	85	185	185	285	285	385	385	485	485	585	585	685	685	785
F	6	6	8	8	10	10	12	12	14	14	16	16	18	18	20
G	4	6	6	8	8	10	10	12	14	14	16	16	18	18	20
H	3	3	3	3	3	3	3	3	3	3	3	3	3	3	3
I	1	1	1	1	1	1	1	1	1	1	1	1	1	1	1
Mass (kg)	w/o brake	1.6	1.9	2.2	2.5	2.8	3.1	3.4	3.7	4	4.3	4.6	4.9	5.2	5.5
	w/ brake	1.8	2.1	2.4	2.7	3	3.3	3.6	3.9	4.2	4.5	4.8	5.1	5.4	5.7

LCE-5MR Dimensions

Motor Right Side

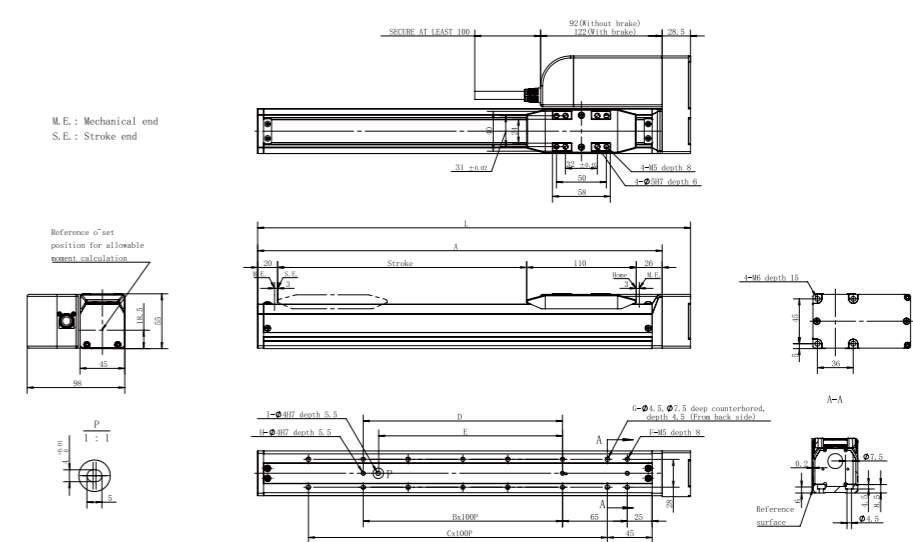

Stroke	100	150	200	250	300	350	400	450	500	550	600	650	700	750	800
	L	284.5	334.5	384.5	434.5	484.5	534.5	584.5	634.5	684.5	734.5	784.5	834.5	884.5	934.5
A	256	306	356	406	456	506	556	606	656	706	756	806	856	906	956
B	1	1	2	2	3	3	4	4	5	5	6	6	7	7	8
C	1	2	2	3	3	4	4	5	5	6	6	7	7	8	8
D	100	100	200	200	300	300	400	400	500	500	600	600	700	700	800
E	85	85	185	185	285	285	385	385	485	485	585	585	685	685	785
F	6	6	8	8	10	10	12	12	14	14	16	16	18	18	20
G	4	6	6	8	8	10	10	12	14	14	16	16	18	18	20
H	3	3	3	3	3	3	3	3	3	3	3	3	3	3	3
I	1	1	1	1	1	1	1	1	1	1	1	1	1	1	1
Mass (kg)	w/o brake	1.6	1.9	2.2	2.5	2.8	3.1	3.4	3.7	4	4.3	4.6	4.9	5.2	5.5
	w/ brake	1.8	2.1	2.4	2.7	3	3.3	3.6	3.9	4.2	4.5	4.8	5.1	5.4	5.7

LCE-5ML Dimensions

Motor Left Side

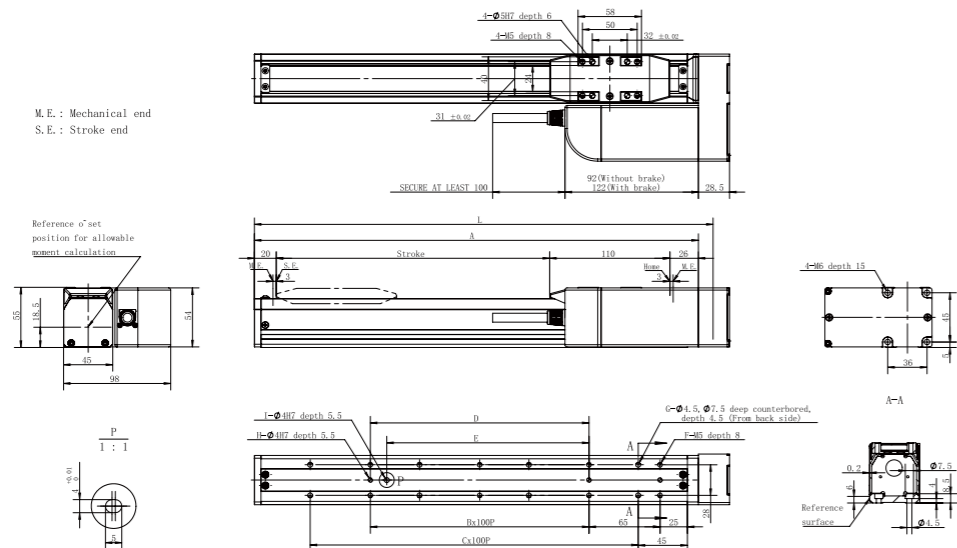

Stroke	100	150	200	250	300	350	400	450	500	550	600	650	700	750	800
	L	284.5	334.5	384.5	434.5	484.5	534.5	584.5	634.5	684.5	734.5	784.5	834.5	884.5	934.5
A	256	306	356	406	456	506	556	606	656	706	756	806	856	906	956
B	1	1	2	2	3	3	4	4	5	5	6	6	7	7	8
C	1	2	2	3	3	4	4	5	5	6	6	7	7	8	8
D	100	100	200	200	300	300	400	400	500	500	600	600	700	700	800
E	85	85	185	185	285	285	385	385	485	485	585	585	685	685	785
F	6	6	8	8	10	10	12	12	14	14	16	16	18	18	20
G	4	6	6	8	8	10	10	12	14	14	16	16	18	18	20
H	3	3	3	3	3	3	3	3	3	3	3	3	3	3	3
I	1	1	1	1	1	1	1	1	1	1	1	1	1	1	1
Mass (kg)	w/o brake	1.6	1.9	2.2	2.5	2.8	3.1	3.4	3.7	4	4.3	4.6	4.9	5.2	5.5
	w/ brake	1.8	2.1	2.4	2.7	3	3.3	3.6	3.9	4.2	4.5	4.8	5.1	5.4	5.7

LCE-5MB Dimensions

Motor Bottom Side

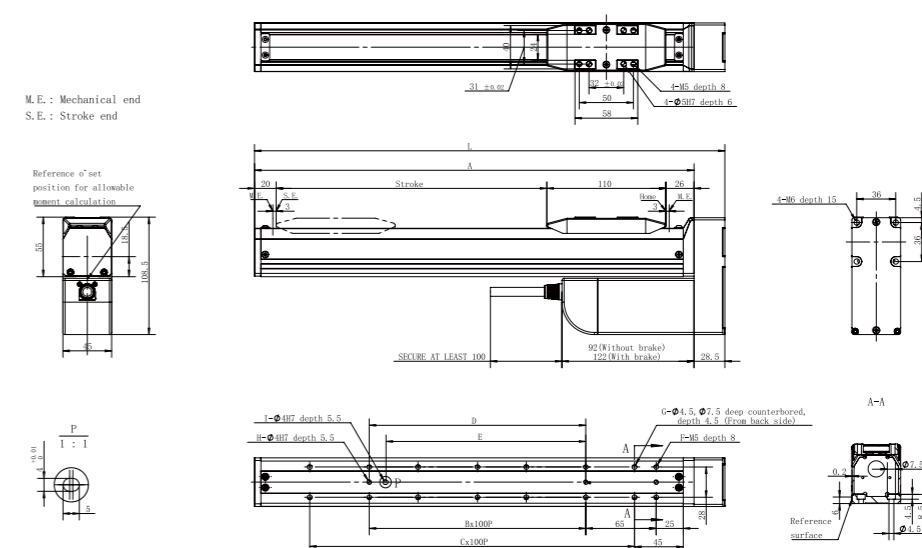

Stroke	100	150	200	250	300	350	400	450	500	550	600	650	700	750	800
	L	284.5	334.5	384.5	434.5	484.5	534.5	584.5	634.5	684.5	734.5	784.5	834.5	884.5	934.5
A	256	306	356	406	456	506	556	606	656	706	756	806	856	906	956
B	1	1	2	2	3	3	4	4	5	5	6	6	7	7	8
C	1	2	2	3	3	4	4	5	5	6	6	7	7	8	8
D	100	100	200	200	300	300	400	400	500	500	600	600	700	700	800
E	85	85	185	185	285	285	385	385	485	485	585	585	685	685	785
F	6	6	8	8	10	10	12	12	14	14	16	16	18	18	20
G	4	6	6	8	8	10	10	12	14	14	16	16	18	18	20
H	3	3	3	3	3	3	3	3	3	3	3	3	3	3	3
I	1	1	1	1	1	1	1	1	1	1	1	1	1	1	1
Mass (kg)	w/o brake	1.6	1.9	2.2	2.5	2.8	3.1	3.4	3.7	4	4.3	4.6	4.9	5.2	5.5
	w/ brake	1.8	2.1	2.4	2.7	3	3.3	3.6	3.9	4.2	4.5	4.8	5.1	5.4	5.7

LCE-7

LINEAR ELECTRIC CYLINDER

SELECTION METHOD

Cylinder Series	Width	Guide Type	Lead (mm)	Stroke (mm)	Integrated or not	Brake	Cable Mounting Direction	Cable Length	Customized**																																
LCE	7 C		05	100	E	O	B	L1	0																																
	<table border="1"> <tr><td>7C</td><td>Motor Hidden in</td></tr> <tr><td>7ML</td><td>Motor Left Side</td></tr> <tr><td>7MR</td><td>Motor Right Side</td></tr> <tr><td>7MB</td><td>Motor Bottom Side</td></tr> </table>	7C	Motor Hidden in	7ML	Motor Left Side	7MR	Motor Right Side	7MB	Motor Bottom Side		<table border="1"> <tr><td>05</td></tr> <tr><td>10</td></tr> <tr><td>16</td></tr> <tr><td>20</td></tr> </table>	05	10	16	20	100~800mm(50 mm pitch)	E Non-integrated driver	<table border="1"> <tr><td>O</td><td>Without brake</td></tr> <tr><td>W</td><td>With brake</td></tr> </table>	O	Without brake	W	With brake	<table border="1"> <tr><td>B</td><td>Backward^①</td></tr> <tr><td>F</td><td>Forward</td></tr> </table>	B	Backward ^①	F	Forward	<table border="1"> <tr><td>L1</td><td>1m</td></tr> <tr><td>L3</td><td>3m</td></tr> <tr><td>L5</td><td>5m</td></tr> <tr><td>L10</td><td>10m</td></tr> </table>	L1	1m	L3	3m	L5	5m	L10	10m	<table border="1"> <tr><td>0</td><td>No customization</td></tr> <tr><td>1</td><td>Customization</td></tr> </table>	0	No customization	1	Customization
7C	Motor Hidden in																																								
7ML	Motor Left Side																																								
7MR	Motor Right Side																																								
7MB	Motor Bottom Side																																								
05																																									
10																																									
16																																									
20																																									
O	Without brake																																								
W	With brake																																								
B	Backward ^①																																								
F	Forward																																								
L1	1m																																								
L3	3m																																								
L5	5m																																								
L10	10m																																								
0	No customization																																								
1	Customization																																								

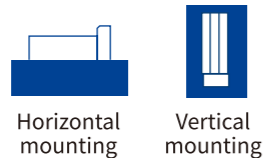
*Note: ① LCE-7ML/MR/MB no tail end backward option
② For customization fees, consult with the sales staff of DH-Robotics

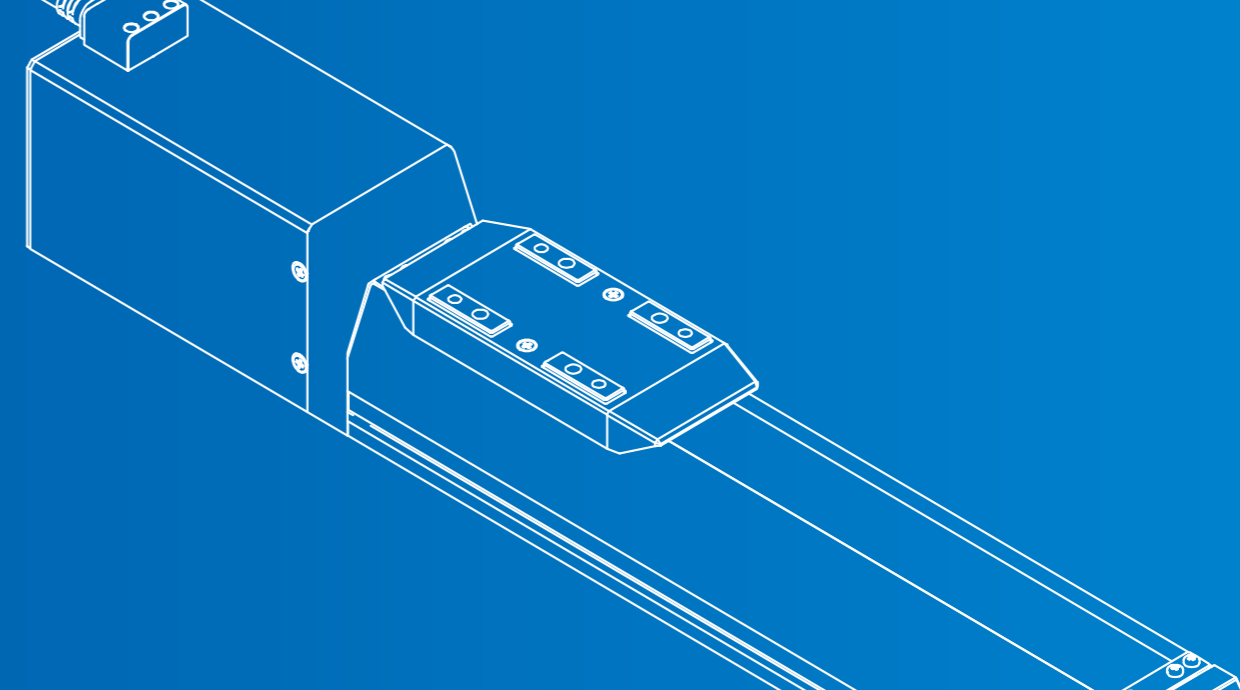

TECHNICAL SPECIFICATIONS

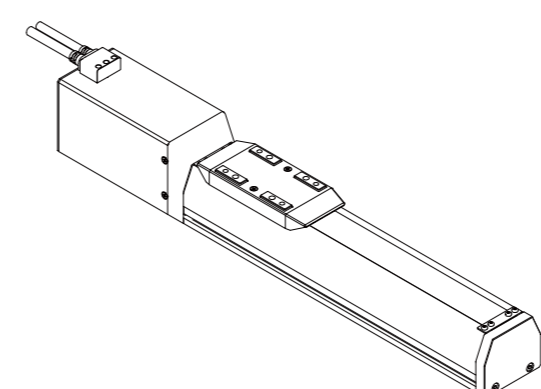

Technical Parameters

Total stroke	100~800mm(50mm pitch)			
Screw lead	5 mm	10 mm	16 mm	20 mm
Rated thrust	680 N	340 N	210 N	170 N
Min. thrust	204 N	102 N	63 N	51 N
Max. acceleration	5000 mm/s ²	5000 mm/s ²	5000 mm/s ²	5000 mm/s ²
Max. speed	250 mm/s	500 mm/s	800 mm/s	1000 mm/s
Max. weight capacity - horizontal	55 kg	50 kg	45 kg	35 kg
Max. weight capacity - vertical	25 kg	15 kg	8 kg	6 kg
Positioning repeatability	±0.02 mm			
Idle stroke	Below 0.1 mm			

Operating Environment

Communication protocol	Standard configurations: Modbus RTU (RS485), Digital I/O Option: EtherCAT Need to adapt to the external purchase of other brands of drives
Rated voltage	24 V DC ± 10%
Rated power	200 W
Protection rating	IP 40
Recommended operating environment	0 to 40°C, below 85% RH
Compliance with international standards	CE, FCC, RoHS

Allowable load moment

Mx	290 N·m
My	290 N·m
Mz	176 N·m

LCE-7C Dimensions

Motor Hidden in

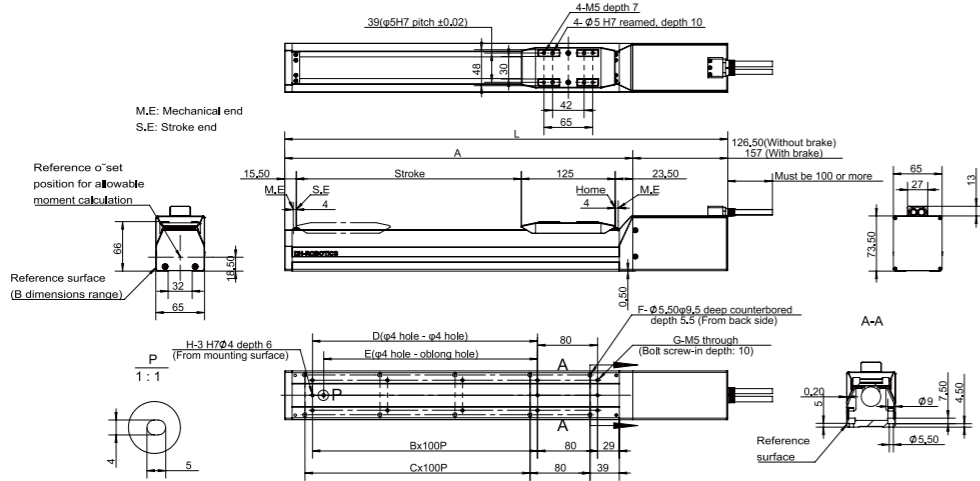

Stroke	100	150	200	250	300	350	400	450	500	550	600	650	700	750	800	
L	w/o brake	390.5	440.5	490.5	540.5	590.5	640.5	690.5	740.5	790.5	840.5	890.5	940.5	990.5	1040.5	1090.5
	w/ brake	421	471	521	571	621	671	721	771	821	871	921	971	1021	1071	1121
A	264	314	364	414	464	514	564	614	664	714	764	814	864	914	964	
B	1	1	2	2	3	3	4	4	5	5	6	6	7	7	8	
C	1	1	2	2	3	3	4	4	5	5	6	6	7	7	8	
D	100	100	200	200	300	300	400	400	500	500	600	600	700	700	800	
E	85	85	185	185	285	285	385	385	485	485	585	585	685	685	785	
F	6	6	8	8	10	10	12	12	14	14	16	16	18	18	20	
G	6	6	8	8	10	10	12	12	14	14	16	16	18	18	20	
H	3	3	3	3	3	3	3	3	3	3	3	3	3	3	3	
Mass (kg)	w/o brake	3.8	4.1	4.4	4.7	5.0	5.3	5.6	5.9	6.2	6.5	6.8	7.1	7.4	7.7	8
	w/ brake	4.2	4.5	4.8	5.1	5.4	5.7	6.0	6.3	6.6	6.9	7.2	7.5	7.8	8.1	8.4

LCE-7MR Dimensions

Motor Right Side

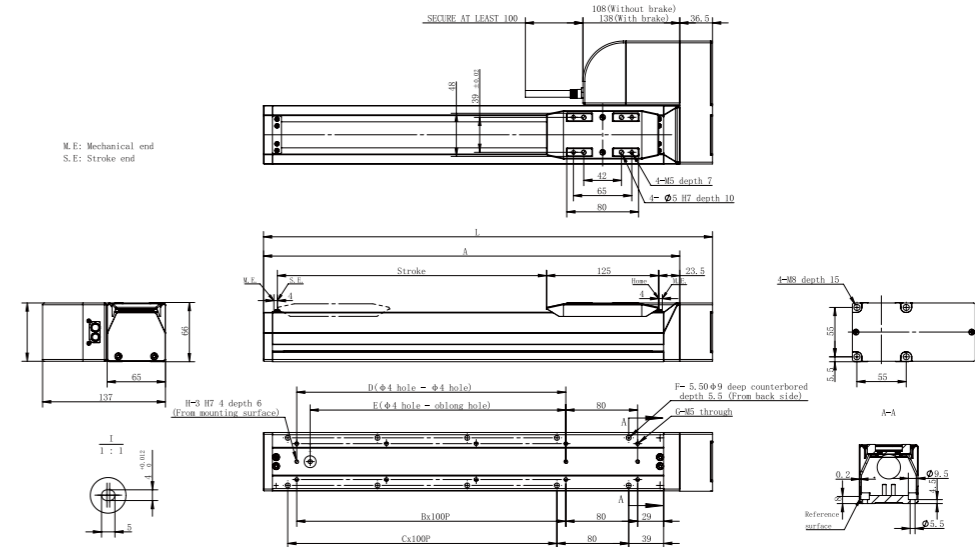

Stroke	100	150	200	250	300	350	400	450	500	550	600	650	700	750	800	
L	w/o brake	390.5	440.5	490.5	540.5	590.5	640.5	690.5	740.5	790.5	840.5	890.5	940.5	990.5	1040.5	
	w/ brake	421	471	521	571	621	671	721	771	821	871	921	971	1021	1071	
A	264	314	364	414	464	514	564	614	664	714	764	814	864	914	964	
B	1	1	2	2	3	3	4	4	5	5	6	6	7	7	8	
C	1	1	2	2	3	3	4	4	5	5	6	6	7	7	8	
D	100	100	200	200	300	300	400	400	500	500	600	600	700	700	800	
E	85	85	185	185	285	285	385	385	485	485	585	585	685	685	785	
F	6	6	8	8	10	10	12	12	14	14	16	16	18	18	20	
G	6	6	8	8	10	10	12	12	14	14	16	16	18	18	20	
H	3	3	3	3	3	3	3	3	3	3	3	3	3	3	3	
Mass (kg)	w/o brake	3.8	4.1	4.4	4.7	5.0	5.3	5.6	5.9	6.2	6.5	6.8	7.1	7.4	7.7	8
	w/ brake	4.2	4.5	4.8	5.1	5.4	5.7	6.0	6.3	6.6	6.9	7.2	7.5	7.8	8.1	8.4

LCE-7ML Dimensions

Motor Left Side

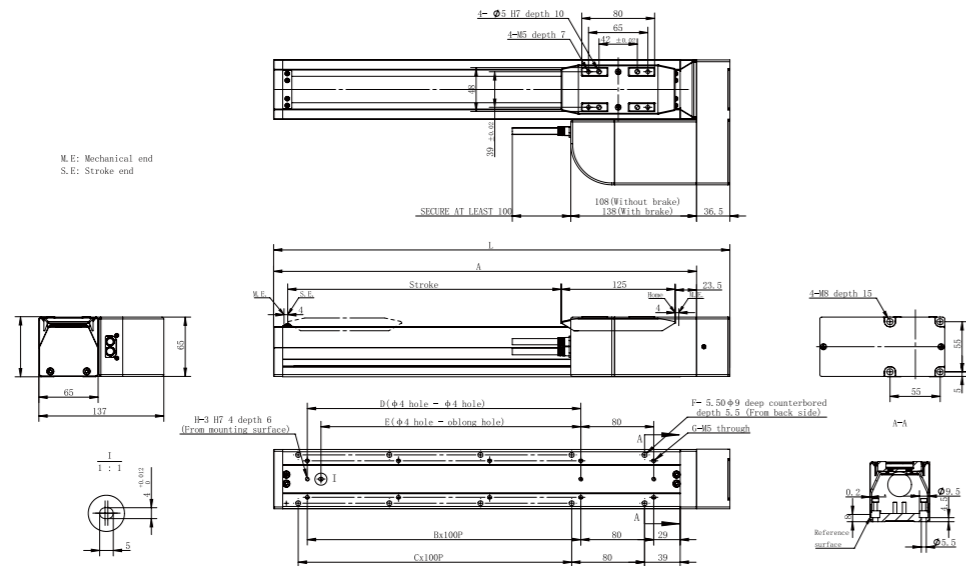

Stroke	100	150	200	250	300	350	400	450	500	550	600	650	700	750	800	
L	w/o brake	390.5	440.5	490.5	540.5	590.5	640.5	690.5	740.5	790.5	840.5	890.5	940.5	990.5	1040.5	
	w/ brake	421	471	521	571	621	671	721	771	821	871	921	971	1021	1071	
A	264	314	364	414	464	514	564	614	664	714	764	814	864	914	964	
B	1	1	2	2	3	3	4	4	5	5	6	6	7	7	8	
C	1	1	2	2	3	3	4	4	5	5	6	6	7	7	8	
D	100	100	200	200	300	300	400	400	500	500	600	600	700	700	800	
E	85	85	185	185	285	285	385	385	485	485	585	585	685	685	785	
F	6	6	8	8	10	10	12	12	14	14	16	16	18	18	20	
G	6	6	8	8	10	10	12	12	14	14	16	16	18	18	20	
H	3	3	3	3	3	3	3	3	3	3	3	3	3	3	3	
Mass (kg)	w/o brake	3.8	4.1	4.4	4.7	5.0	5.3	5.6	5.9	6.2	6.5	6.8	7.1	7.4	7.7	8
	w/ brake	4.2	4.5	4.8	5.1	5.4	5.7	6.0	6.3	6.6	6.9	7.2	7.5	7.8	8.1	8.4

LCE-7MB Dimensions

Motor Bottom Side

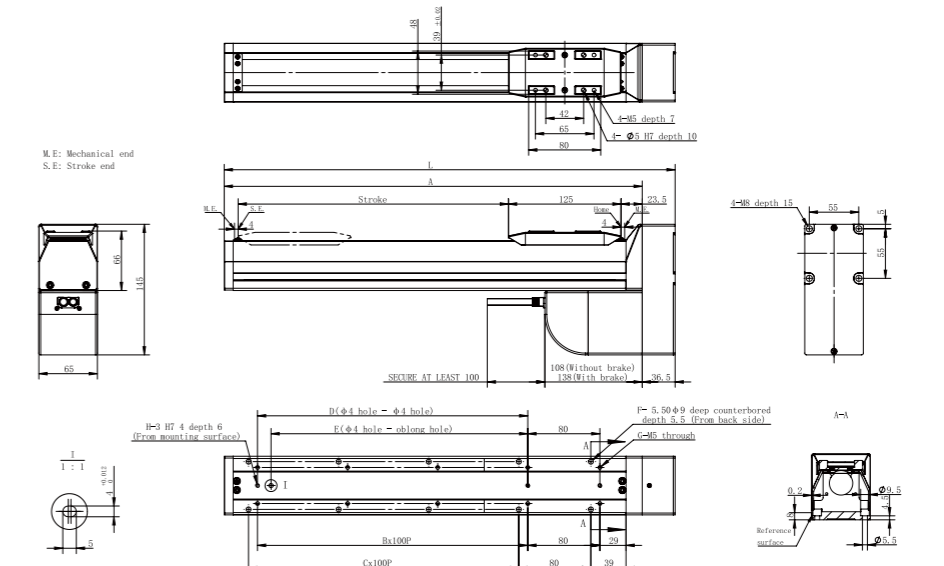

Stroke	100	150	200	250	300	350	400	450	500	550	600	650	700	750	800	
L	w/o brake	390.5	440.5	490.5	540.5	590.5	640.5	690.5	740.5	790.5	840.5	890.5	940.5	990.5	1040.5	
	w/ brake	421	471	521	571	621	671	721	771	821	871	921	971	1021	1071	
A	264	314	364	414	464	514	564	614	664	714	764	814	864	914	964	
B	1	1	2	2	3	3	4	4	5	5	6	6	7	7	8	
C	1	1	2	2	3	3	4	4	5	5	6	6	7	7	8	
D	100	100	200	200	300	300	400	400	500	500	600	600	700	700	800	
E	85	85	185	185	285	285	385	385	485	485	585	585	685	685	785	
F	6	6	8	8	10	10	12	12	14	14	16	16	18	18	20	
G	6	6	8	8	10	10	12	12	14	14	16	16	18	18	20	
H	3	3	3	3	3	3	3	3	3	3	3	3	3	3	3	
Mass (kg)	w/o brake	3.8	4.1	4.4	4.7	5.0	5.3	5.6	5.9	6.2	6.5	6.8	7.1	7.4	7.7	8
	w/ brake	4.2	4.5	4.8	5.1	5.4	5.7	6.0	6.3	6.6	6.9	7.2	7.5	7.8	8.1	8.4

RCE-5

ELECTRIC ROD TYPE CYLINDER

SELECTION METHOD

Cylinder Series	Width	Guide Type	Lead (mm)	Stroke (mm)	Integrated or not	Brake	Cable Mounting Direction	Cable Length	Customized**																															
RCE	5 C		05	100	E	O	B	L1	0																															
	<table border="1"> <tr><td>5C</td><td>Motor Hidden in</td></tr> <tr><td>5ML</td><td>Motor Left Side</td></tr> <tr><td>5MR</td><td>Motor Right Side</td></tr> <tr><td>5MB</td><td>Motor Bottom Side</td></tr> </table>	5C	Motor Hidden in	5ML	Motor Left Side	5MR	Motor Right Side	5MB	Motor Bottom Side		<table border="1"> <tr><td>05</td></tr> <tr><td>10</td></tr> <tr><td>20</td></tr> </table>	05	10	20	100~800mm(50 mm pitch)	E Non-integrated driver	<table border="1"> <tr><td>O</td><td>Without brake</td></tr> <tr><td>W</td><td>With brake</td></tr> </table>	O	Without brake	W	With brake	<table border="1"> <tr><td>B</td><td>Backward*</td></tr> <tr><td>F</td><td>Forward</td></tr> </table>	B	Backward*	F	Forward	<table border="1"> <tr><td>L1</td><td>1m</td></tr> <tr><td>L3</td><td>3m</td></tr> <tr><td>L5</td><td>5m</td></tr> <tr><td>L10</td><td>10m</td></tr> </table>	L1	1m	L3	3m	L5	5m	L10	10m	<table border="1"> <tr><td>0</td><td>No customization</td></tr> <tr><td>1</td><td>Customization</td></tr> </table>	0	No customization	1	Customization
5C	Motor Hidden in																																							
5ML	Motor Left Side																																							
5MR	Motor Right Side																																							
5MB	Motor Bottom Side																																							
05																																								
10																																								
20																																								
O	Without brake																																							
W	With brake																																							
B	Backward*																																							
F	Forward																																							
L1	1m																																							
L3	3m																																							
L5	5m																																							
L10	10m																																							
0	No customization																																							
1	Customization																																							

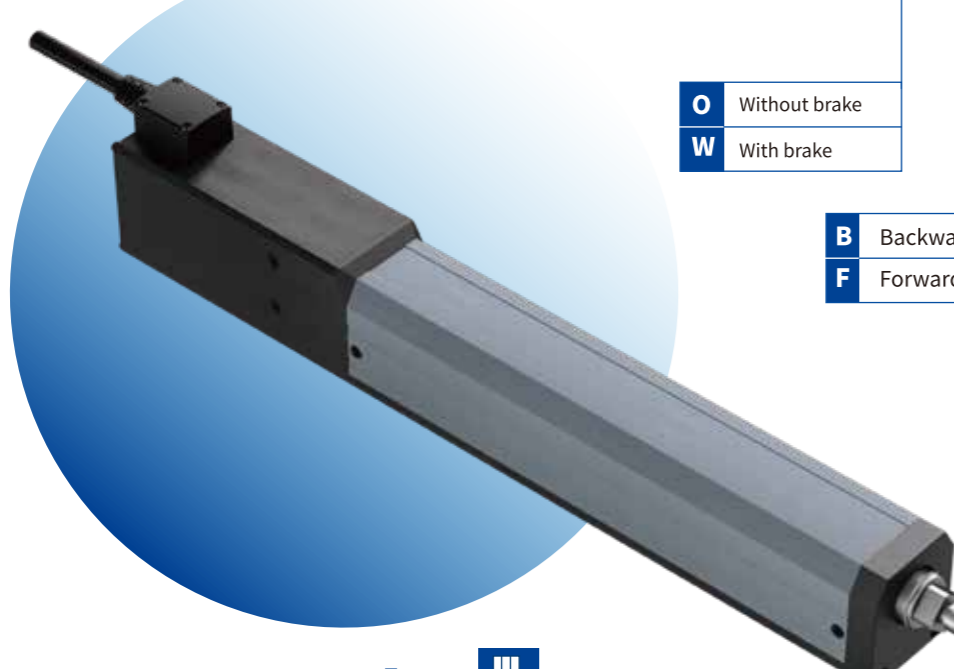



Horizontal mounting



Vertical mounting

*Note: ① RCE-5ML/MR/MB no tail end backward option
 ② For customization fees, consult with the sales staff of DH-Robotics

TECHNICAL SPECIFICATIONS

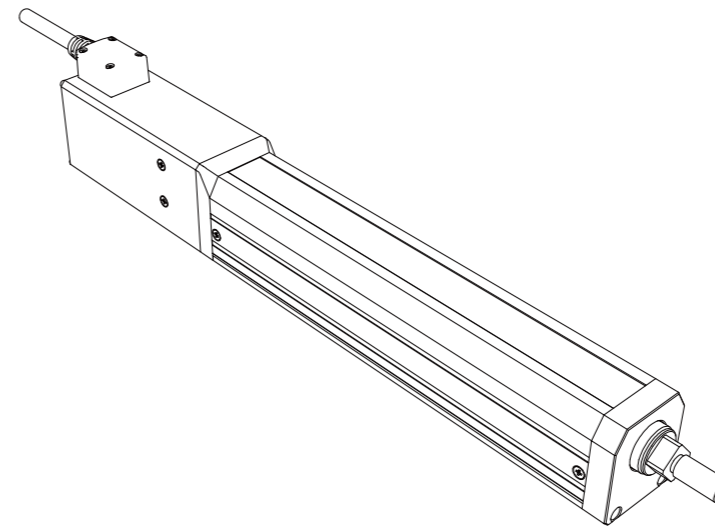

*① This load condition requires the external addition of auxiliary guides to withstand radial loads.

*② With the rod fully retracted into the main body, the angular displacement at the rod end due to the maximum allowable static torque is measured (using the initial value as a reference).

Technical Parameters

Total stroke	100~800mm(50 mm pitch)		
Screw lead	5 mm	10 mm	20 mm
Rated thrust	320 N	160 N	80 N
Min. thrust	96 N	48 N	24 N
Max. speed	250 mm/s	500 mm/s	1000 mm/s
Max. weight capacity - horizontal*①	35 kg	25 kg	15 kg
Max. weight capacity - vertical	10 kg	5 kg	2.5 kg
Positioning repeatability	±0.02 mm		
Idle stroke	Below 0.1 mm		
Rod Diameter	φ22mm		
Maximum Allowable Static Torque at Rod End	1.5 N·m		
Maximum Angular Displacement at Rod End*②	±1°		

Operating Environment

Communication protocol	Standard configurations: Modbus RTU (RS485), Digital I/O Option: EtherCAT Need to adapt to the external purchase of other brands of drives
Rated voltage	24 V DC ± 10%
Rated power	100 W
Protection rating	IP 40
Recommended operating environment	0 to 40°C, below 85% RH
Compliance with international standards	CE, FCC, RoHS

RCE-5C Dimensions

Motor Hidden in

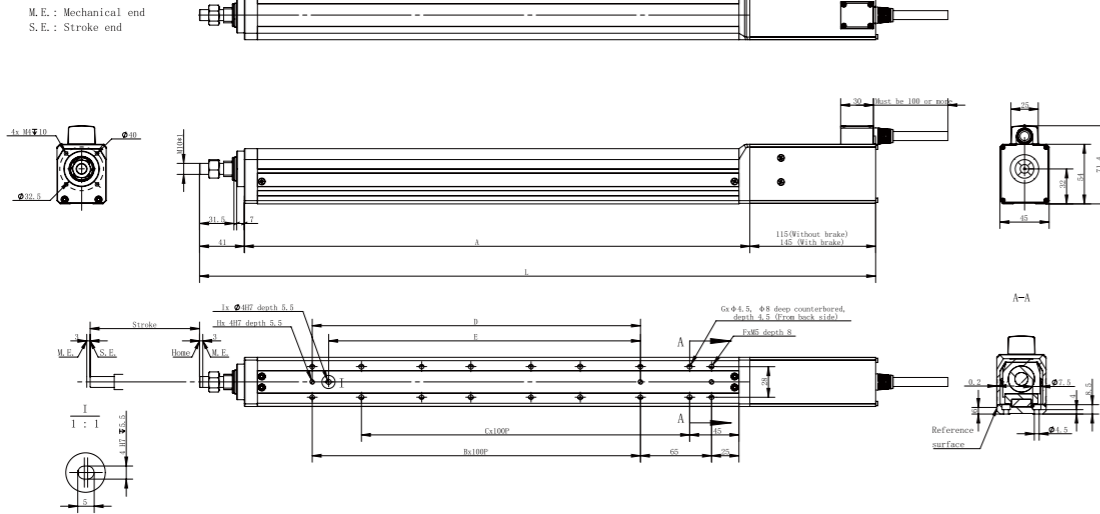

Stroke	50	100	150	200	250	300	350	400	450	500	550	600	650	700	750	800	
L	398	418	408	518	568	618	668	718	768	818	868	918	968	1018	1068	1118	
A	212	262	312	362	412	462	512	562	612	662	712	762	812	862	912	962	
B	0	1	1	2	2	3	3	4	4	5	5	6	6	7	7	8	
C	1	1	2	2	3	3	4	4	5	5	6	6	7	7	8	8	
D	0	100	100	200	200	300	300	400	400	500	500	600	600	700	700	800	
E	0	85	85	185	185	285	285	385	385	485	485	585	585	685	685	785	
F	4	6	6	8	8	10	10	12	12	14	14	16	16	18	18	20	
G	4	4	6	6	8	8	10	10	12	14	14	16	16	18	18	18	
H	2	3	3	3	3	3	3	3	3	3	3	3	3	3	3	3	
I	0	1	1	1	1	1	1	1	1	1	1	1	1	1	1	1	
Mass (kg)	w/o brake	1.9	2.2	2.5	2.8	3.1	3.4	3.7	4	4.3	4.6	4.9	5.2	5.5	5.8	6.1	6.4
	w/ brake	2.1	2.4	2.7	3	3.3	3.6	3.9	4.2	4.5	4.8	5.1	5.4	5.7	6	6.3	6.6

RCE-5MR Dimensions

Motor Right Side

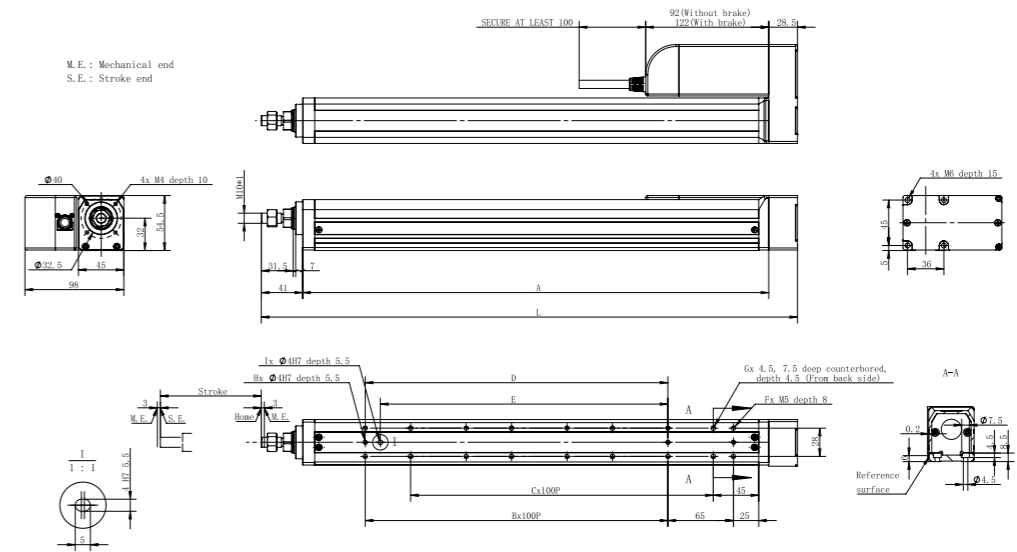

Stroke	50	100	150	200	250	300	350	400	450	500	550	600	650	700	750	800	
L	281.5	331.5	381.5	431.5	481.5	531.5	581.5	631.5	681.5	731.5	781.5	831.5	881.5	931.5	981.5	1031.5	
A	212	262	312	362	412	462	512	562	612	662	712	762	812	862	912	962	
B	0	1	1	2	2	3	3	4	4	5	5	6	6	7	7	8	
C	1	1	2	2	3	3	4	4	5	5	6	6	7	7	8	8	
D	0	100	100	200	200	300	300	400	400	500	500	600	600	700	700	800	
E	0	85	85	185	185	285	285	385	385	485	485	585	585	685	685	785	
F	4	6	6	8	8	10	10	12	12	14	14	16	16	18	18	20	
G	4	4	6	6	8	8	10	10	12	14	14	16	16	18	18	18	
H	2	3	3	3	3	3	3	3	3	3	3	3	3	3	3	3	
I	0	1	1	1	1	1	1	1	1	1	1	1	1	1	1	1	
Mass (kg)	w/o brake	1.9	2.2	2.5	2.8	3.1	3.4	3.7	4	4.3	4.6	4.9	5.2	5.5	5.8	6.1	6.4
	w/ brake	2.1	2.4	2.7	3	3.3	3.6	3.9	4.2	4.5	4.8	5.1	5.4	5.7	6	6.3	6.6

RCE-5ML Dimensions

Motor Left Side

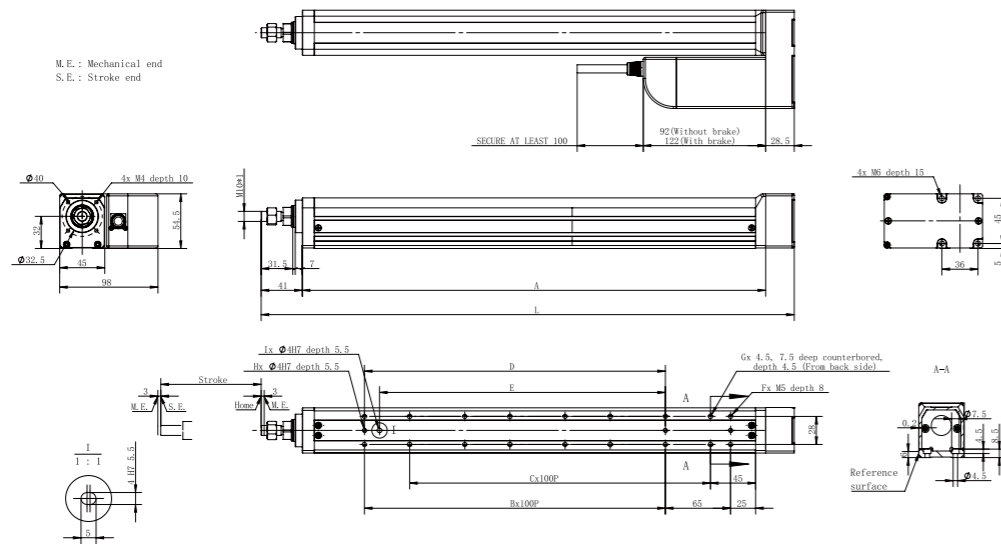

Stroke	50	100	150	200	250	300	350	400	450	500	550	600	650	700	750	800	
L	281.5	331.5	381.5	431.5	481.5	531.5	581.5	631.5	681.5	731.5	781.5	831.5	881.5	931.5	981.5	1031.5	
A	212	262	312	362	412	462	512	562	612	662	712	762	812	862	912	962	
B	0	1	1	2	2	3	3	4	4	5	5	6	6	7	7	8	
C	1	1	2	2	3	3	4	4	5	5	6	6	7	7	8	8	
D	0	100	100	200	200	300	300	400	400	500	500	600	600	700	700	800	
E	0	85	85	185	185	285	285	385	385	485	485	585	585	685	685	785	
F	4	6	6	8	8	10	10	12	12	14	14	16	16	18	18	20	
G	4	4	6	6	8	8	10	10	12	14	14	16	16	18	18	18	
H	2	3	3	3	3	3	3	3	3	3	3	3	3	3	3	3	
I	0	1	1	1	1	1	1	1	1	1	1	1	1	1	1	1	
Mass (kg)	w/o brake	1.9	2.2	2.5	2.8	3.1	3.4	3.7	4	4.3	4.6	4.9	5.2	5.5	5.8	6.1	6.4
	w/ brake	2.1	2.4	2.7	3	3.3	3.6	3.9	4.2	4.5	4.8	5.1	5.4	5.7	6	6.3	6.6

RCE-5MB Dimensions

Motor Bottom Side

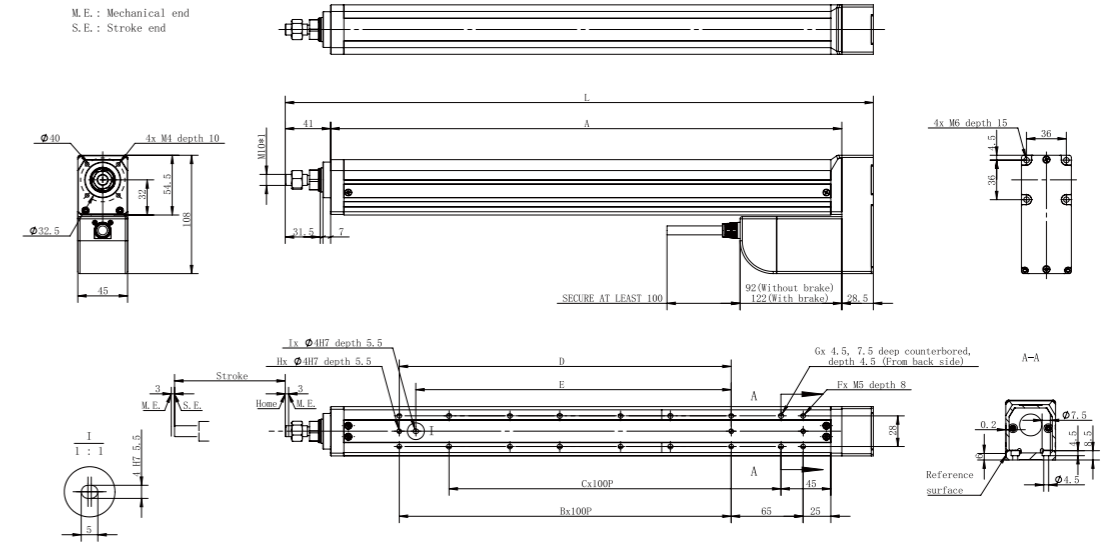

Stroke	50	100	150	200	250	300	350	400	450	500	550	600	650	700	750	800	
L	281.5	331.5	381.5	431.5	481.5	531.5	581.5	631.5	681.5	731.5	781.5	831.5	881.5	931.5	981.5	1031.5	
A	212	262	312	362	412	462	512	562	612	662	712	762	812	862	912	962	
B	0	1	1	2	2	3	3	4	4	5	5	6	6	7	7	8	
C	1	1	2	2	3	3	4	4	5	5	6	6	7	7	8	8	
D	0	100	100	200	200	300	300	400	400	500	500	600	600	700	700	800	
E	0	85	85	185	185	285	285	385	385	485	485	585	585	685	685	785	
F	4	6	6	8	8	10	10	12	12	14	14	16	16	18	18	20	
G	4	4	6	6	8	8	10	10	12	14	14	16	16	18	18	18	
H	2	3	3	3	3	3	3	3	3	3	3	3	3	3	3	3	
I	0	1	1	1	1	1	1	1	1	1	1	1	1	1	1	1	
Mass (kg)	w/o brake	1.9	2.2	2.5	2.8	3.1	3.4	3.7	4	4.3	4.6	4.9	5.2	5.5	5.8	6.1	6.4
	w/ brake	2.1	2.4	2.7	3	3.3	3.6	3.9	4.2	4.5	4.8	5.1	5.4	5.7	6	6.3	6.6

SAC-N

SINGLE AXIS DRIVER

SELECTION METHOD

Drives Series	Type	Communication interface	Voltage	Rated Current	Encoder	Customized																				
SAC	N	M1	K	03	A1	0																				
	<table border="1"> <tr><td>N</td><td>Standard</td></tr> <tr><td>NF</td><td>Standard+ Force Sensor</td></tr> </table>	N	Standard	NF	Standard+ Force Sensor	<table border="1"> <tr><td>M1</td><td>ModbusRTU(RS485)+Pulse+NPN</td></tr> <tr><td>M2</td><td>ModbusRTU(RS485)+Pulse+PNP</td></tr> </table>	M1	ModbusRTU(RS485)+Pulse+NPN	M2	ModbusRTU(RS485)+Pulse+PNP	<table border="1"> <tr><td>K</td><td>24 V</td></tr> </table>	K	24 V	<table border="1"> <tr><td>03</td><td>3 A</td></tr> <tr><td>10</td><td>10 A</td></tr> </table>	03	3 A	10	10 A	<table border="1"> <tr><td>A1</td><td>Incremental ABZ+ Single-Turn Absolute SSI</td></tr> </table>	A1	Incremental ABZ+ Single-Turn Absolute SSI	<table border="1"> <tr><td>0</td><td>No customization</td></tr> <tr><td>1</td><td>Customization</td></tr> </table>	0	No customization	1	Customization
N	Standard																									
NF	Standard+ Force Sensor																									
M1	ModbusRTU(RS485)+Pulse+NPN																									
M2	ModbusRTU(RS485)+Pulse+PNP																									
K	24 V																									
03	3 A																									
10	10 A																									
A1	Incremental ABZ+ Single-Turn Absolute SSI																									
0	No customization																									
1	Customization																									



Adaptable Products: MCE Series and LCE-4

TECHNICAL SPECIFICATIONS

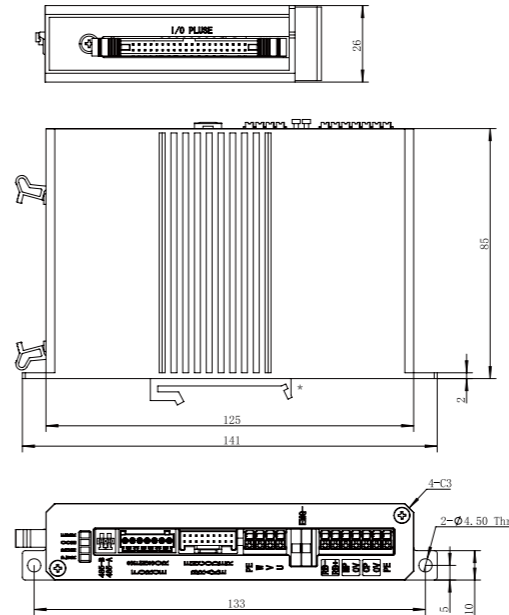

*Guide rail clips are industry standard size and can be removed when installed with screws

Technical Parameters

Number of controllable axes	1
Support control methods	I/O, Pulse(24V), ModbusRTU RS485
Number of points	64
I/O and pulse connection holder	40PIN Connector
Number of I/O	16 in 16 out
Debugging protocols	RS485(Modbus-RTU)
Pulse type	Opticalcoupler
Max. pulse frequency	100Kpps
Brake control	Support
Force-controlled closed-loop control	Support

Operating Environment

Input voltage	24 V DC ±10%
Output Current	3 A(Rated)/9 A(Peak) 10A(Rated)/25A(Peak)
Recommended operating environment	0 to 40°C, below 85% RH
IP class	IP 20
Weigh	300 g

Interface Diagram

1. Power Supply, Discharge, and PE Interface

Logic Power Supply Interface: Supplies power to internal logic circuits, brake, and some external interfaces.

Motor Power Supply Interface: Supplies power to the motor for motion.

PE (Protective Earth) Interface: Connects to the equipment's protective earth (ground) connection.

2. Emergency Stop

Emergency Stop Control Interface: Used for emergency stop control.

3. Motor Interface

UVW and PE connections for the motor of the actuator.

4. Feedback and Brake Interface

Connects to the encoder and brake of the actuator.

5. Sensor Interface:

Relay sensor interface.

6. RS485 Interface

Used for debugging, control, and monitoring.

7. Indicators

Power indicator and status indicator.

8. I/O and Pulse (24V) Interface

40-Pin Terminal Block, including I/O interfaces and pulse(24V) input interfaces.

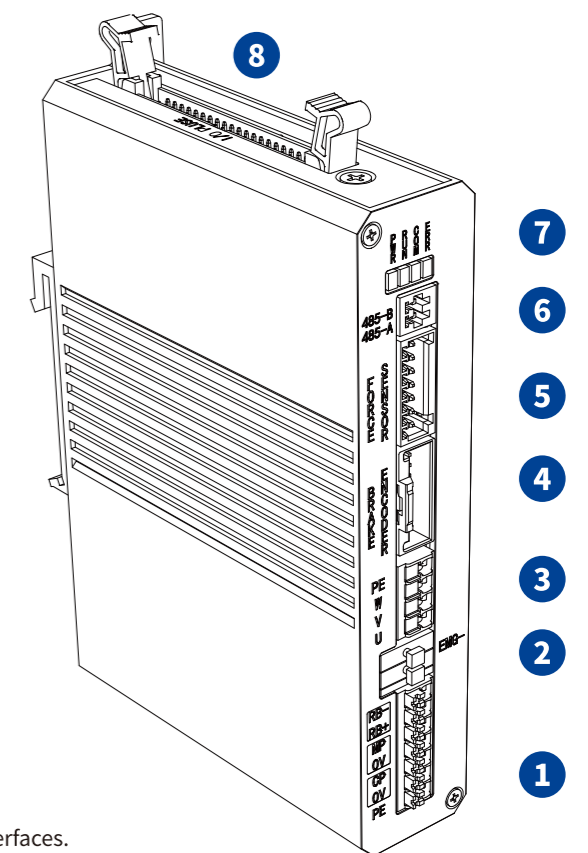

SAC-S

SINGLE AXIS DRIVER

SELECTION METHOD

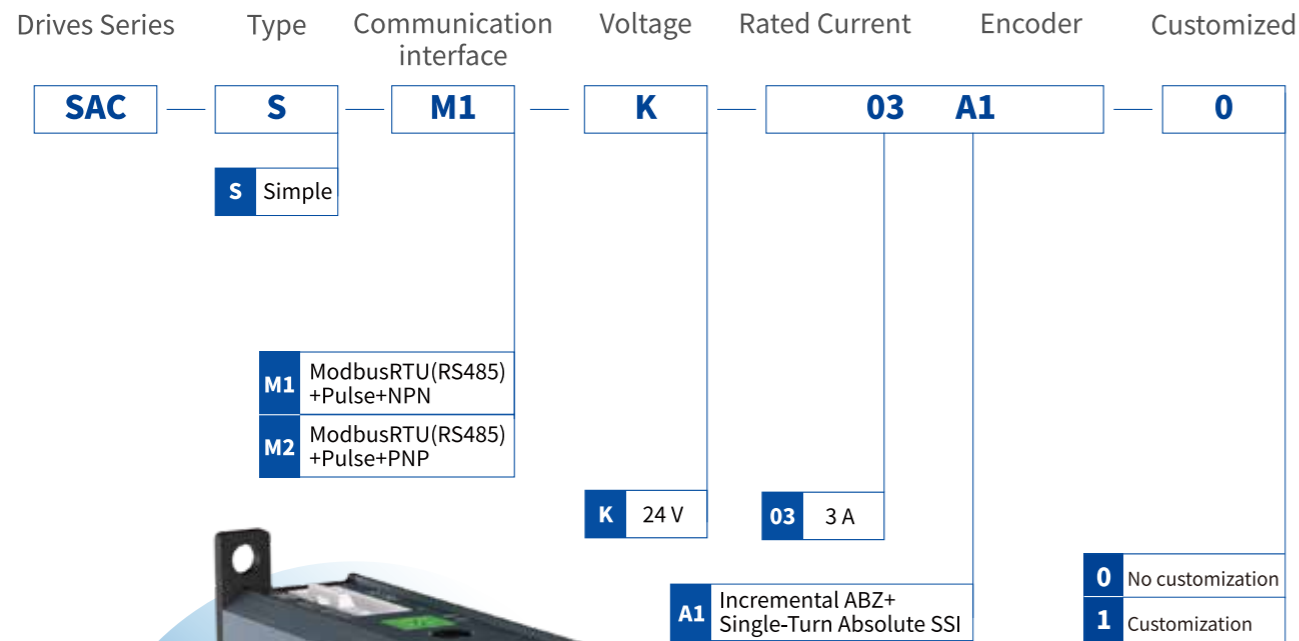

Adaptable Products: MCE Series and LCE-4

TECHNICAL SPECIFICATIONS

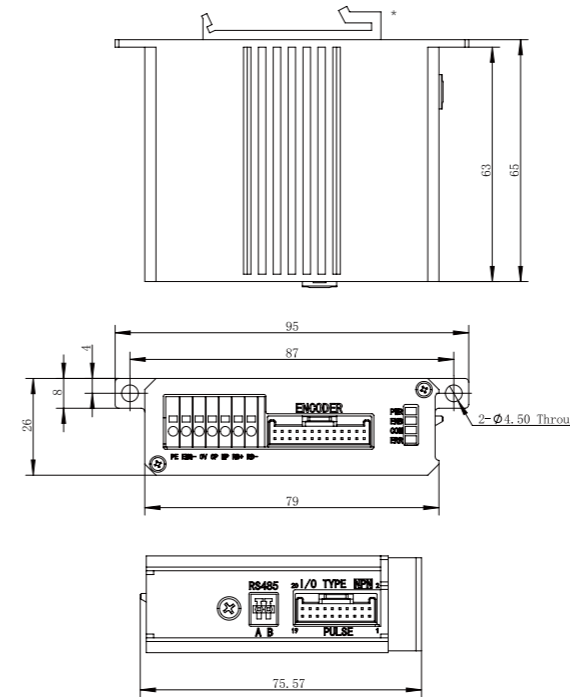

*Guide rail clips are industry standard size and can be removed when installed with screws

Technical Parameters

Number of controllable axes	1
Support control methods	I/O, Pulse(24V), ModbusRTU RS485
Number of points	16
I/O and pulse connection holder	20PIN Connector
Number of I/O	8 in 8 out
Debugging protocols	RS485(Modbus-RTU)
Pulse type	Opticalcoupler
Max. pulse frequency	100Kpps
Brake control	Support
Force-controlled closed-loop control	No support

Operating Environment

Input voltage	24 V DC ±10%
Output Current	3 A(Rated)/9 A(Peak)
Recommended operating environment	0 to 40°C, below 85% RH
IP class	IP 20
Weigh	150 g

Interface Diagram

1. Power Supply, Discharge, Emergency Stop, and PE Interface

Logic Power Supply Interface: Supplies power to internal logic circuits, brake, and some external interfaces.

Motor Power Supply Interface: Supplies power to the motor for motion.

PE (Protective Earth) Interface: Connects to the equipment's protective earth (ground) connection.

2. Actuator Interface

Connects to the actuator of the electric cylinder, including motor power line, encoder line, and brake line interfaces.

3. Indicators

Power indicator and status indicator.

4. RS485 Interface

Used for debugging, control, and monitoring.

5. I/O and Pulse(24V) Interface

20-Pin Terminal Block, including I/O interfaces and pulse(24V) input interfaces.

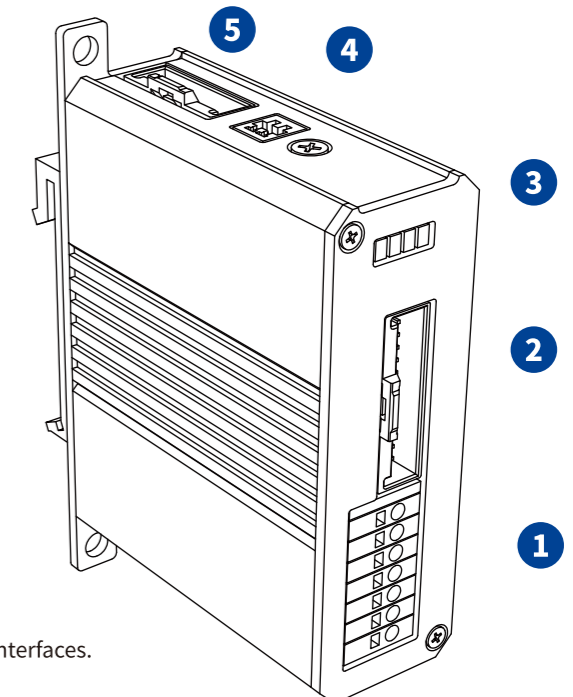

SAC-N2

DUAL AXIS DRIVER

SELECTION METHOD

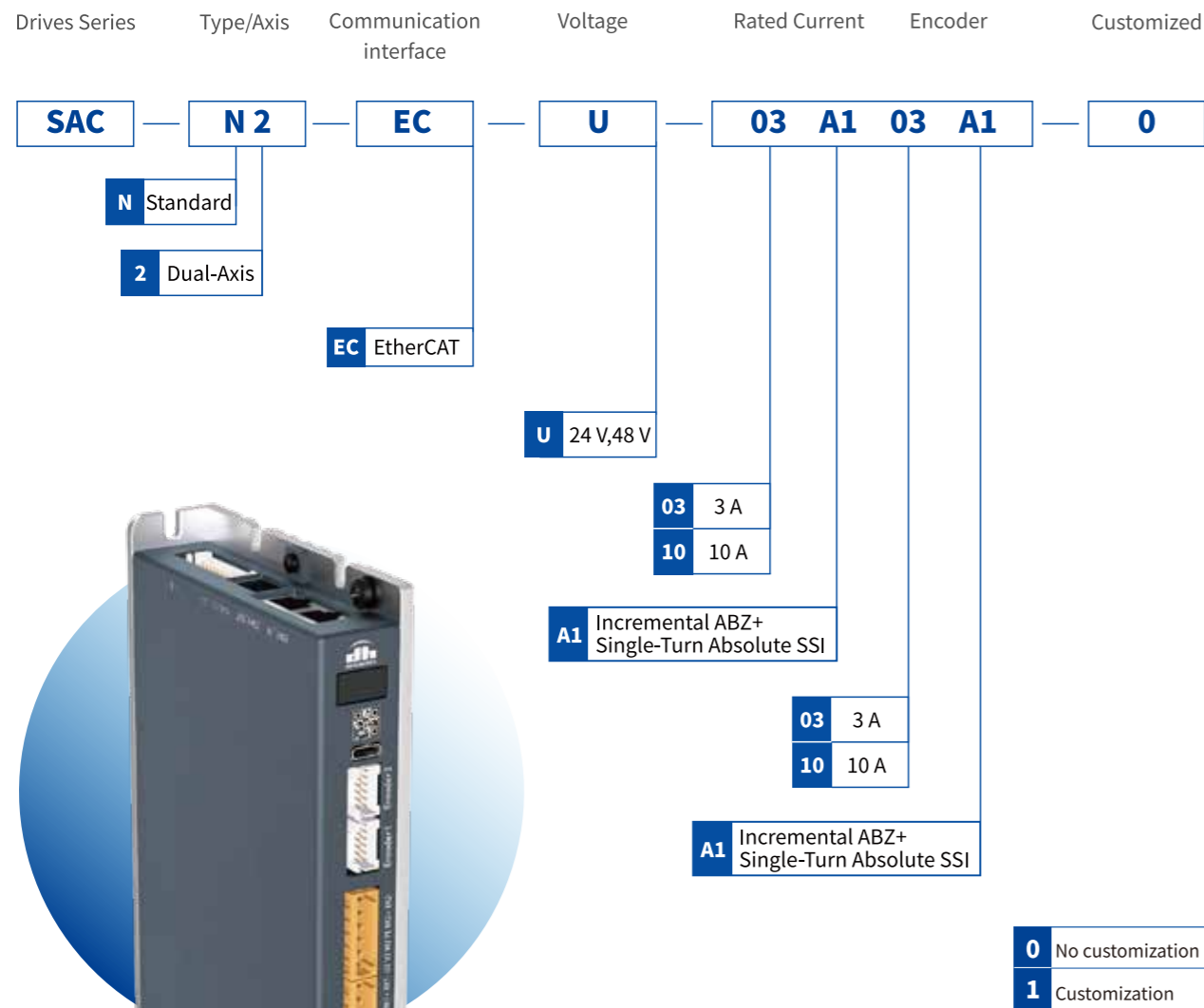

TECHNICAL SPECIFICATIONS

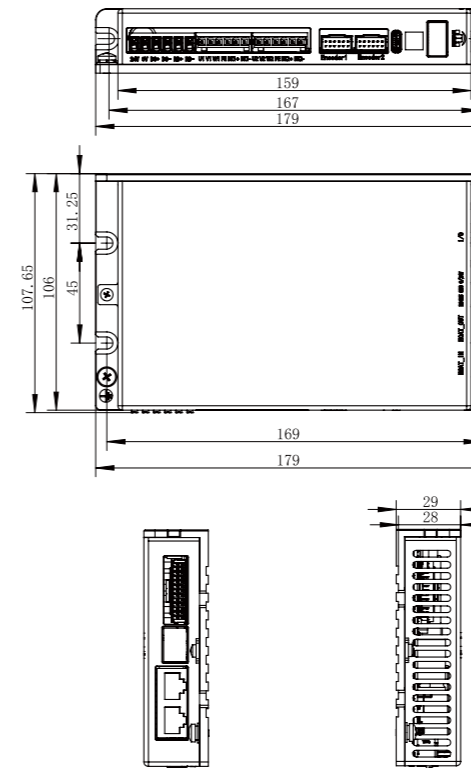

Technical Parameters

Controlled Axis	2
Supported Control Methods	EtherCAT, IO, MODBUS
EtherCAT Control Modes	Position Mode, Velocity Mode, Torque Mode, and Hybrid Mode
Power Supply Voltage	24 V
Motor Voltage	24 V
Output Rated Current	3 A / 10 A
Encoder	Supports BissC\SSI\Endat\Motegi\ABZ
Limit Switch, Home Position, Probe	Supported

Operating Environment

Overload	3 times overload for more than 2.5 seconds
Minimum EtherCAT Period	200 us
Filters	4 or more
Closed-Loop Control	Supported
Gantry Control	Synchronized in nanoseconds
High-Precision Encoder and Sampling	Supports 23-bit resolution
Auto-Tuning Gain	Supported
Protection	Overcurrent, Overvoltage, Overheating protection; STO (Safe Torque Off) function
Speed Loop Response	3.5 KHz
Weight	<0.6 KG
Maximum Power	24 V, 240 W; 48 V 480 W
Protection Level	IP20
Operating Temperature	0~55 °C

Interface Diagram

1. Logic Power (24 V / 0 V):

Logic power interface, supplying 24V power to internal control chips, communication chips, IO, and STO.

2. Motor Power (DC+ / DC-):

Motor power interface, capable of accepting 24/48V, supplying power to the motor.

3. Overvoltage Discharge Resistor (RB+ / RB-):

External overvoltage discharge resistor interface.

4. Axis 1 Power Line, PE, Brake:

EAxis 1 motor three-phase power output U1V1W1, PE (ground), and brake control interface BK1+ / BK1-.

5. Axis 2 Power Line, PE, Brake:

2 motor three-phase power output U2V2W2, PE (ground), and brake control interface BK2+ / BK2-.

6. Axis 1 Encoder:

Axis 1 encoder differential interface Encoder1, supports ABZ/SSI/BissC/Motegi, etc.

7. Axis 2 Encoder:

Axis 2 encoder differential interface Encoder2, supports ABZ/SSI/BissC/Motegi, etc.

8. Debug Interface:

Type-C debug interface, connecting to the upper computer for debugging.

9. Panel Display:

Three-digit LED display showing the current status of the drive.

10. ECAT_IN:

EtherCAT bus input interface.

11. ECAT_OUT:

EtherCAT bus output interface.

12. STO and 485 Interface:

STO and 485 interfaces with an attached 24V power supply.

13. I/O and Pulse(24V) Interface:

Axis 1 and Axis 2 I/O, PE (ground), and pulse(24V) interfaces with an attached 24V power supply.

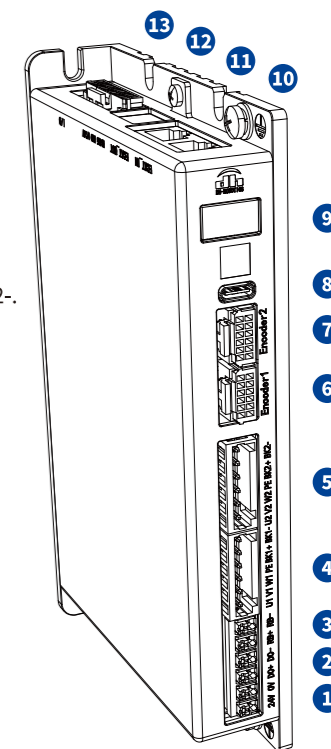

DH-Robotics' Gripper and Cylinder Communication Protocol Conversion Box

The communication within DH-Robotics' Servo Gripper and Servo Electric Cylinder defaults to Modbus RTU (RS485) and a small number of I/O. If customers choose other communication protocols, they will need to use the communication protocol conversion box. The following communication protocol conversion boxes are available for selection:

	Communication Protocol Conversion Box Name	Ordering Model
	EtherCAT 1-1	M2E-B1-1
	EtherCAT 1-4	M2E-B1-4
	EtherCAT转 I/O 1-more	Please contact our technical staff confirm the specific parameters
	TCP/IP 1-1	M2T-B1-1-YBT
	PROFINET 1-2	M2P2-B1-2-HJ
	PROFINET 1-11	M2P-B1-11-9

Customer trust

More than 800 customers around the world are using DH-Robotics products

The number of customers continues to grow rapidly. . .



Product Distribution

Chinese Agent Distribution Cities

Beijing/Changchun/Changsha/Chengdu/Chongqing/Dalian/Dongguan/
Guangzhou/Hangzhou/Hefei/Jinan/Nanchang/Nanjing/Ningbo/Qingdao/
Shanghai/Shenyang/Shenzhen/Suzhou/Wuhan/Wuxi/Xi'an/Xiamen/Yantai/
Yangzhou/Zhengzhou/Zhuhai

Overseas Agents Distribution Area

Europe: Spain / France / Italy / Germany / UK / Czech Republic / Romania / Russia / Netherlands / Lithuania / Sweden / Denmark / Norway

Asia: Israel / Bangladesh / India / Japan / Thailand / South Korea / Malaysia

Australia: Australia / New Zealand

America: United States / Mexico

Middle East: Saudi Arabia / Tunisia / Türkiye