



AHRS IMU Sensor | WT901C

The Robust Acceleration, Angular velocity, Angle & Magnetic filed Detector

The WT901C is a IMU sensor device, detecting acceleration, angular velocity, angle as well as magnetic filed. The robust housing and the small outline makes it perfectly suitable for industrial applications such as condition monitoring and predictive maintenance. Configuring the device enables the customer to address a broad variety of application by interpreting the sensor data by smart algorithms and Kalman filtering.

BUILT-IN SENSORS



Accelerometer

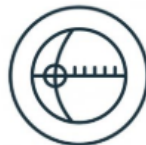

Gyroscope

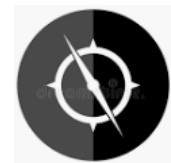

Magnetometer



Tutorial Link

[Google Drive](#)

Link to instructions DEMO:

[WITMOTION Youtube Channel](#)

[WT901C Playlist](#)

If you have technical problems or cannot find the information that you need in the provided documents, please contact our support team. Our engineering team is committed to providing the required support necessary to ensure that you are successful with the operation of our AHRS sensors.

Contact

[Technical Support Contact Info](#)

Application

- AGV Truck
- Platform Stability
- Auto Safety System
- 3D Virtual Reality
- Industrial Control
- Robot
- Car Navigation
- UAV
- Truck-mounted Satellite Antenna Equipment

WT901C RS232 | Datasheet v23-0104 | www.wit-motion.com



Contents

Tutorial Link	- 2 -
Contact.....	- 2 -
Application	- 2 -
Contents.....	- 3 -
1 Overview.....	- 4 -
2 Features.....	- 5 -
3 Specification	- 6 -
3.1 Parameter	- 6 -
3.2 Size.....	- 12 -
3.3 Axial Direction	- 12 -
4 Pin Definition	- 13 -
5 Casing Specification	- 14 -
6 Communication Protocol	- 15 -



1 Overview

WT901C's scientific name is AHRS IMU sensor. A sensor measures 3-axis angle, angular velocity, acceleration and magnetic field. Its strength lies in the algorithm which can calculate three-axis angle accurately.

WT901C is employed where the highest measurement accuracy is required. WT901C offers several advantages over competing sensor:

- Heated for best data availability: new WITMOTION patented zero-bias automatic detection calibration algorithm outperforms traditional accelerometer sensor
- High precision Roll Pitch Yaw (X Y Z axis) Acceleration + Angular Velocity + Angle + Magnetic Field output
- Low cost of ownership: remote diagnostics and lifetime technical support by WITMOTION service team
- Developed tutorial: providing manual, datasheet, Demo video, PC software, mobile phone APP, and 51 serial, STM32, Arduino, and Matlab sample code, communication protocol
- WITMOTION sensors have been praised by thousands of engineers as a recommended attitude measurement solution



2 Features

- The default baud rate of this device is 9600 and could be changed.
- The interface of this product only leads to a serial port
- The module consists of a high precision gyroscope, accelerometer, geomagnetic field and barometer sensor. The product can solve the current real-time motion posture of the module quickly by using the high-performance microprocessor, advanced dynamic solutions and Kalman filter algorithm.
- The advanced digital filtering technology of this product can effectively reduce the measurement noise and improve the measurement accuracy.
- Maximum 200Hz data output rate. Output content can be arbitrarily selected, the output speed 0.2HZ~ 200HZ adjustable.

3 Specification

3.1 Parameter

Parameter	Specification
➤ Working Voltage	RS232: 5V-36V
➤ Current	<40mA
➤ Size	51.3mm x 36mm X 15mm
➤ Data	Angle: X Y Z, 3-axis Acceleration: X Y Z, 3-axis Angular Velocity: X Y Z, 3-axis Magnetic Field : X Y Z, 3-axis Time, Quaternion
➤ Output frequency	0.2Hz--200Hz
➤ Interface	Serial RS232 level
➤ Baud rate	9600(default, could be changed)

Measurement Range & Accuracy

Sensor	Measurement Range	Accuracy/ Remark
➤ Accelerometer	X, Y, Z, 3-axis ±16g	Accuracy: 0.01g Resolution: 16bit Stability: 0.005g
➤ Gyroscope	X, Y, Z, 3-axis -±2000°/s	Resolution: 16bit Stability: 0.05°/s
➤ Magnetometer	X, Y, Z, 3-axis ±4900μT	0.15μT/LSB typ. (16-bit)
➤ Angle/ Inclinator	X, Y, Z, 3-axis X, Z-axis: ±180° Y ±90° (Y-axis 90° is singular point)	Accuracy: X, Y-axis: 0.05° Z-axis: 1°(after magnetic calibration)



Accelerometer Parameters

Parameter	Condition	Typical Value
Range		$\pm 16g$
Resolution		0.0005(g/LSB)
RMS noise	Bandwidth = 100Hz	0.75~1mg-rms
Static zero drift	Placed horizontally	$\pm 20 \sim 40mg$
Temperature drift	-40°C ~ +85°C	$\pm 0.15mg/^\circ C$
Bandwidth		5~256Hz

Gyro Parameters

Parameter	Condition	Typical Value
Range		$\pm 2000^\circ/s$
Resolution	$\pm 2000^\circ/s$	0.061($^\circ/s$)/(LSB)
RMS noise	Bandwidth = 100Hz	0.028~0.07($^\circ/s$)-rms
Static zero drift	Placed horizontally	$\pm 0.5 \sim 1^\circ/s$
Temperature drift	-40°C ~ +85°C	$\pm 0.005 \sim 0.015 (^\circ/s)/^\circ C$
Bandwidth		5~256Hz



Magnetometer parameters

Parameter	Condition	Typical Value
Range		± 2 Gauss
Resolution	± 2 Gauss	0.0667mGauss/LSB

Pitch and roll angle parameters

Parameter	Condition	Typical Value
Range		XY: $\pm 180^\circ$; Y: $\pm 90^\circ$
Inclination accuracy		0.2°
Resolution	Placed horizontally	0.0055°
Temperature drift	-40°C ~ +85°C	$\pm 0.5 \sim 1^\circ$

Heading Angle Parameter

Parameter	Condition	Typical Value
Range		Z:±180°
Heading accuracy	9-axis algorithm, magnetic field calibration, dynamic/static 6-axis algorithm, static	1° (without interference from magnetic field) 0.5° (Dynamic integral cumulative error exists)
Resolution	Placed horizontally	0.0055°



Module Parameters

Basic Parameters

Parameter	Condition	Minimum value	Default	Maximum value
Interface	UART	4800bps	115200bps	230400bps
Output content		3-axis acceleration, 3-axis angular velocity, 3-axis magnetic field, 3-axis angle, magnetic field, quaternion		
Output rate		0.2Hz	10Hz	200Hz
Transmission distance	TTL			1M
	232			10M
Operating temperature		-40°C		85°C
Storage temperature		-40°C		100°C
Shock proof				20000g



Electrical parameters

Parameter	Condition	Min	Default	Max
Supply voltage		5V	12V	36V
Working current	Work (5V)		5.7V	
	Sleep (5V)		0.5mA	

3.2 Size



Parameter	Specification	Tolerance	Comment
Length	51.3	± 0.1	Unit: millimeter.
Width	36	± 0.1	
Height	15	± 0.1	
Weight	13	± 1	Unit: gram

3.3 Axial Direction

The coordinate system used for attitude angle settlement is the northeast sky coordinate system. Place the module in the positive direction, as shown in the figure below, direction left is the Y-axis, the direction forward is the X-axis, and direction upward is the Z-axis. Euler angle represents the rotation order of the coordinate system when the attitude is defined as Z-Y-X, that is, first turn around the Z-axis, then turn around the Y-axis, and then turn around the X-axis.



4 Pin Definition

Interface Standard



PIN	Function
➤ VCC	5-36V input supply
➤ RX	Serial data input, RS232 interface
➤ TX	Serial data output, RS232 interface
➤ GND	Ground

5 Casing Specification

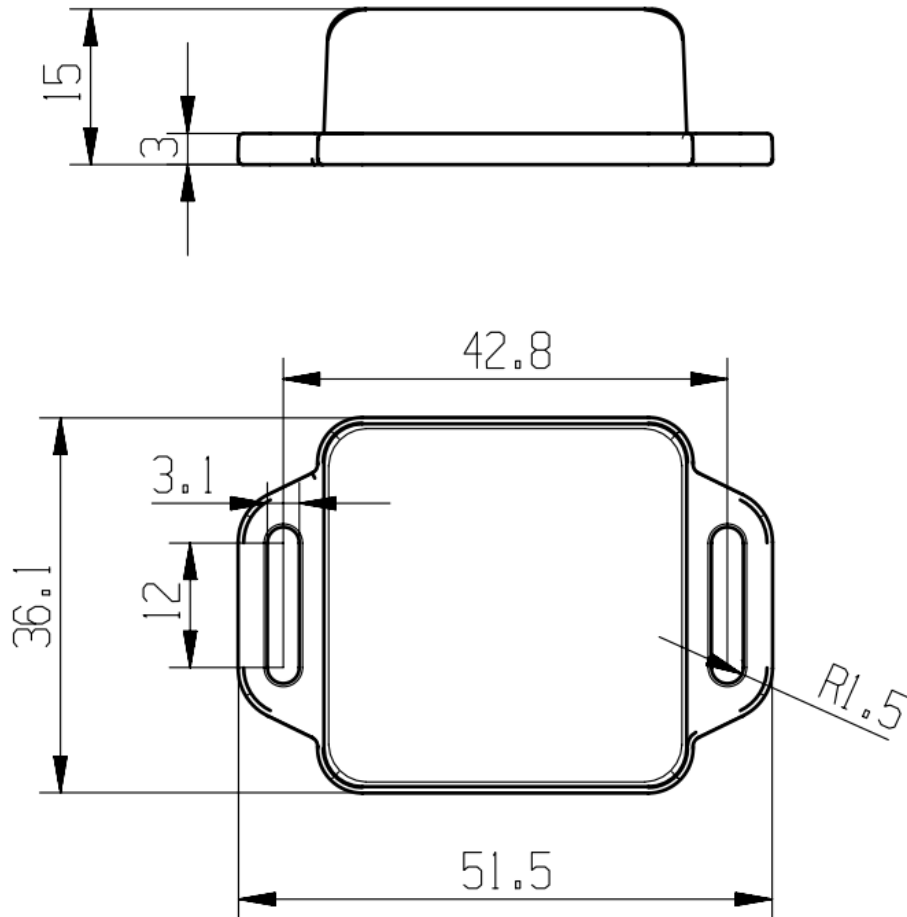



6 Communication Protocol

Level: RS232 level

Baud rate: 4800, 9600 (default), 19200 38400, 57600, 115200, 230400, stop bit and parity

Link to [WITMOTION Protocol](#).