



qTop LTE GNSS BG95/BG96 AMC shield

Data Sheet

Abstract

Data Sheet gives information about the qTop LTE GNSS BG95/BG96 AMC shield. Features and device description.

IBT-QTC-BG9X-AMC-DS

www.iot-bots.com





Table of Contents

Revision History	2
Overview	3
Features	3
Description	4
Functional diagram	6
Pinout	8
Overview	8
Power and Control	9
Modem UART	9
Modem Control and Status	10
I2C BUS	10
Minimal connection, power On / Off	10
PCB Jumpers	11
Overview	11
Modem UART	13
RXD / TXD	13
RTS / CTS	13
GPS UART	13
Modem Control and Status	14
qJam interface	14
RTC Voltage	14
I2C SDA & I2C SCL Pull-ups	14
UID NVM chip Address	15
Network LED	15
Test Points	15
Modem FW Update	17
Getting Started	17
FCC & IC Compliance	18
Abbreviations	19
Trademark notice	19
Ordering info	19



Revision History

NoNo	Version	Date	Author	Description
1	1.0	03.01.2021	lotbotscom	Initial
2	1.1	07.03.2021	lotbotscom	Content update
3				



Overview

qTop BG95/BG96 (BG9x) LTE GNSS Arduino MKR Compatible Shields are the easiest way to bring the cellular wireless and GNSS location functionality to your Arduino MKR Compatible board DIY IOT project.

qTop BG95/BG96 LTE GNSS shields are based on Quectel BG95/BG96 LTE CAT M1 / NB-IOT / EGPRS GNSS wireless modules correspondently.

qTop BG95/BG96 shields are developed to be used together with popular Arduino MKR Compatible IOT boards to build various DIY IOT cellular connectivity projects.

Features

- LTE Cellular and GNSS Navigation all-in-one: Multi-mode LPWA and GNSS Quectel BG95/BG96 module based shield;
- Reliable and Optimized Power Management: Integrated High Efficiency Single Inductor Buck-Boost TPS63020 converter;
- Flexible and compatible interface: All modem UARTs pins are accessible through PCB jumpers and 3,3V translators;
- Flexible antenna options: Two built-in u.FL connectors for Cellular and GNSS antennas to be connected;
- Shield identification feature: UID EEPROM chip integrated allows to keep Shield info, version and unique ID of the product;
- Sensor Add-On capability: Built in qJam connector gives opportunity to bring to the system any qJam family devices;
- Popular IOT board compatibility: pin-to-pin compatible with favorite Arduino MKR IOT boards;
- Shock & Vibration resistant SIM Card Holder: World's smallest hinged nano-SIM Card holder integrated.

Description

qTop BG9x LTE GNSS AMC Shields (Devices) are Arduino MKR Compatible PCB shields to be used for building DIY IOT project together with Arduino MKR Compatible IOT board to get cellular connectivity and GNSS location info for the system to be implemented.

There are two options exists:

- qTop BG96 LTE GNSS AMC Shield: based on BG96 Quectel Modem:

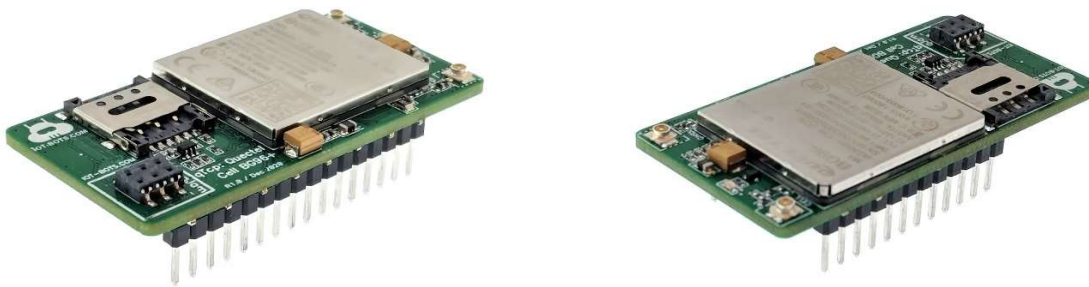

Pic.1. qTop BG96 LTE GNSS Shield

- qTop BG95 LTE GNSS AMC Shield: based on BG95 Quectel Modem:



Pic.2. qTop BG95 LTE GNSS Shield

High quality four layers FR-4 PCB is used to carry all Device components on, placed at both PCB sides. The Device dimensions are shown at picture below.

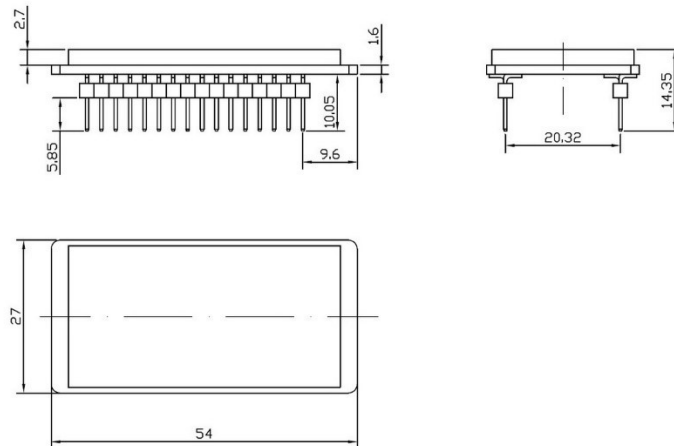

Note : All dimensions are preliminary

Pic.3. qTop BG9x LTE GNSS AMC Shield dimensions (mm)

The main qTop BG9x LTE GNSS AMC Shield components highlighted at picture below.

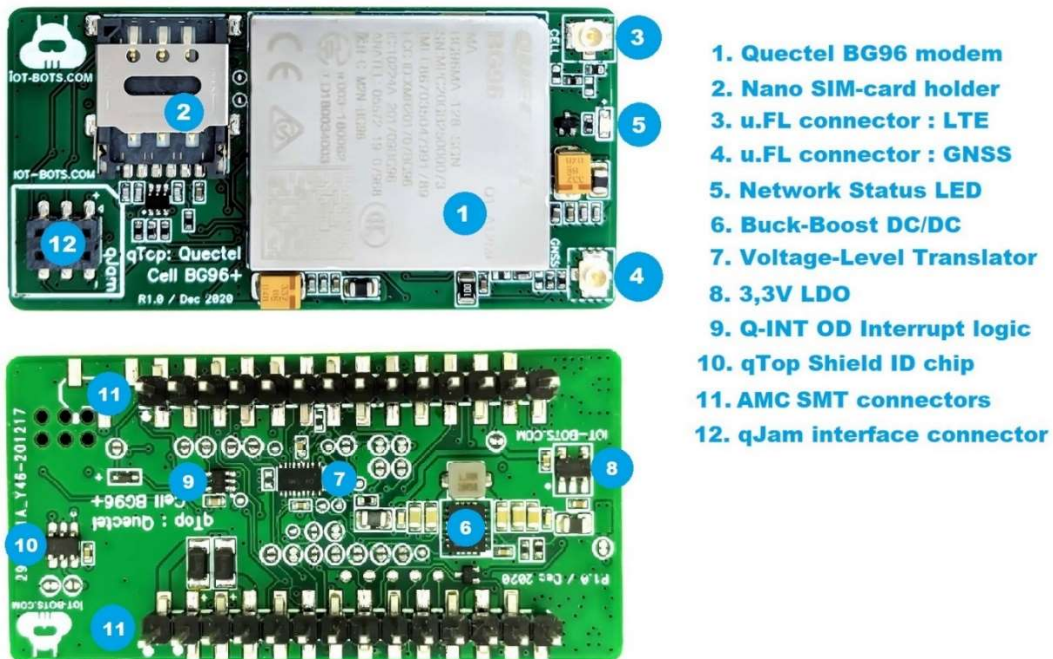

Pic.4. qTop BG9x LTE GNSS AMC Shield components

Functional diagram

The core part of BG95 shield is BG95-M3 and BG96 shield is BG96 Quectel modems. BG95/BG96 is an embedded IoT (LTE Cat M1, LTE Cat NB1 and EGPRS) wireless communication module. It provides data connectivity on LTE-TDD/LTE-FDD/GPRS/EDGE networks and supports half-duplex operation in LTE networks. It also provides GNSS functionality to meet customers' specific application demands.

More info about modems could be found at Quectel website:

BG95-M3 : <https://www.quectel.com/product/lte-bg95-m3/>

BG96 : <https://www.quectel.com/product/lte-bg96-cat-m1-nb1-egprs/>

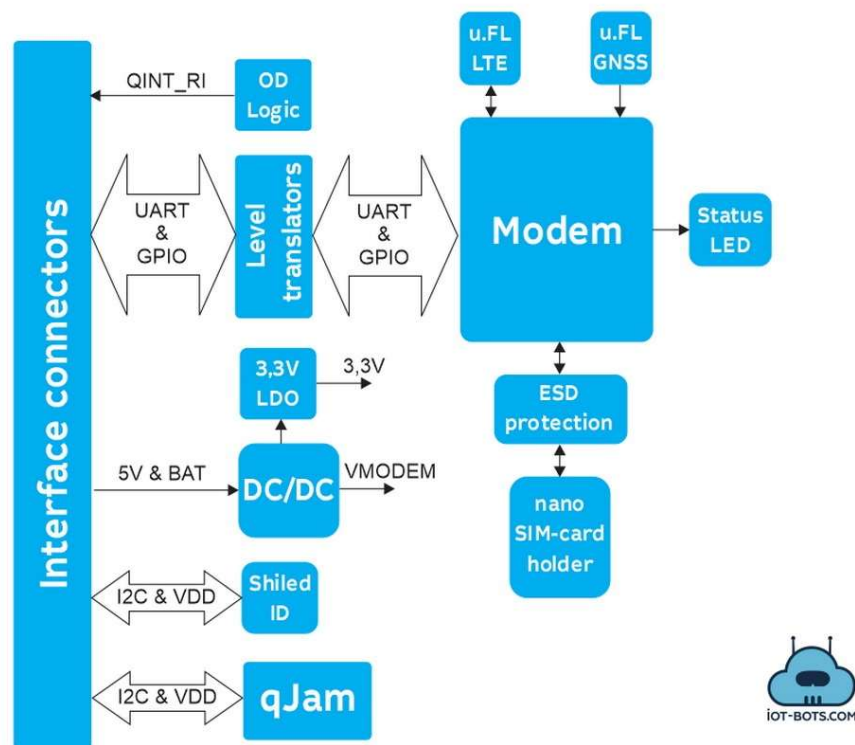

Pic.6. qTop BG9x LTE GNSS AMC Shield Functional Diagram

Two u.FL connectors are used for internal or external Antennas (LTE and GNSS). Shield provides 3,3VDC power for active GNSS antenna.



Shield supports nano-SIM card to be inserted into Hinged Lid SIM Card Holder type located at the top of PCB. All SIM-card traces are ESD-protected.

Network indication LED, located in the center of the edge of the board lets observe modem network status.

TPS63020 Buck-Boost Converter is used to power modem, so shield is fully functional even with input voltage drops down to 3.3 V.

DC/DC output voltage is also used to power LDO, which provides 3,3 VDC for the level translators, Open-Drain (OD) logic IC and active GNSS antenna to be connected.

Level translators are used to shift voltage levels between IOT board with 3,3V signals and 1,8V levels used by modem logic.

All qTop Shields have device ID feature - each qTop shield has integrated EEPROM chip with UID feature. EEPROM is preprogrammed by manufacture (IOT-BOTS.COM) with shield type and info, so IOT controller with appropriate FW loaded, at power up time could identify type of the shield and configures FW to work with. So, no needs to re-flash IOT controller with new FW if you want to change shield, for example, to change wireless connectivity from LTE to LoRa : just turn power off, replace a shield and turn power on - system will recognize new HW plugged in and start working with that device. UID feature could be used by End User as particular device identification (for sure, IMEI could be used as well) or to keep a small piece of data (device settings, as example).

OD logic is simple gate IC, used to convert push-pull RI modem signal to open-drain logic to be compatible with Q_INT line of qJam interface - so many different devices (sensors, actuators, modems, etc) interrupt outputs could be connected to single line to be used by IOT controller to react on system or external events.

And finally, to bring more value for our qTop products, each qTop shield (except GNSS shields) supports qJam connection system : it is developed by our team, tiny 6-pin connecting system, which allows end user to easily bring small I2C devices (sensors, actuators, system devices, memories) to an IOT solution to be developed. Need just put qJam compatible device into qJam connector of the controller board - no cables, soldering or wires required. It has power (3,3V), I2C bus, Q_INT open-

drain interrupt line and Q_IO GPIO line to be used by qJam device as additional control or status signal.

So, any qJam compatible device could be located at the top of the Shield to bring more feature to an IOT solution or project you are working on.

Pinout

Overview

qTop BG9x LTE GNSS AMC Shields could be used with most Arduino MKR Compatible IOT boards (Main Board).

The following picture and Table 1 detail the pinout of qTop BG9x LTE GNSS AMC Shield. Some pins are not connected by default to give more flexibility to our product. So, they could be connected to the Shield blocks, using PCB jumpers, to bring additional functionality, described in this document below.

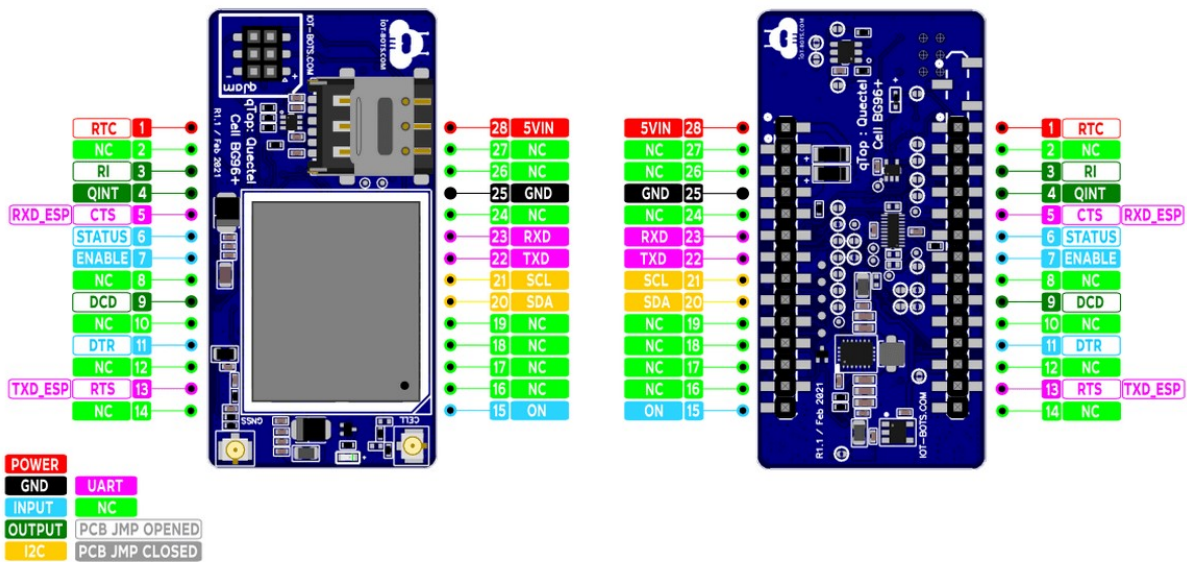

Pic.7. qTop BG9x LTE GNSS AMC Shield Pinout

Table 1

Pin	Name	Description	Type	Default connection	Voltage, V		
					Min	Typ.	Max
1	RTC	RTC Voltage	Input	Not Connected	0	3,0	3,0
2	NC	Not Connected	-	-	-	-	-
3	RI	Modem RI	Input	Not Connected	0	3,3	5,5
4	QINT	qJam Interrupt	Output, OD	Not Connected	0	3,3	5,5
5	CTS	Modem UART CTS	Output, PP	Not Connected	0	3,3	5,5
6	STATUS	Modem STATUS	Output, PP	Not Connected	0	3,3	5,5
7	ENABLE	Device Power On/Off	Input	Device Power On/Off	0	3,3	5,5
8	NC	Not Connected	-	-	-	-	-
9	DCD	Modem DCD Pin	Output, PP	Not Connected	0	3,3	5,5
10	NC	Not Connected	-	-	-	-	-
11	DTR	Modem UART DTR	Input	Not Connected	0	3,3	5,5
12	NC	Not Connected	-	-	-	-	-
13	RTS	Modem UART RTS	Input	Not Connected	0	3,3	5,5
14	NC	Not Connected	-	-	-	-	-
15	ON	Modem On/Off	Input	Modem On/Off	0	3,3	5,5
16	NC	Not Connected	-	-	-	-	-
17	NC	Not Connected	-	-	-	-	-
18	NC	Not Connected	-	-	-	-	-
19	NC	Not Connected	-	-	-	-	-
20	SDA	I2C SDA	IO, OD	I2C SDA	0	3,3	5,5
21	SCL	I2C SCL	Input	I2C SCL	0	3,3	5,5
22	TXD	Modem UART TX	Output, PP	GSM UART TX	0	3,3	5,5
23	RXD	Modem UART RX	Input	GSM UART RX	0	3,3	5,5
24	NC	Not Connected	-	-	-	-	-
25	GND	Ground	Power	Ground	0	0	0
26	NC	Not Connected	-	-	-	-	-
27	NC	Not Connected	-	-	-	-	-
28	5VIN	Power In	Power	Power In	0	3,6...5,0	5,5

Power and Control

- GND : the common ground for all power and logic;
- 5VIN : positive voltage to get qTop shield powered;
- RTC : Real Time Clock battery voltage;
- ENABLE : Device Power On / Off;
- ON : Modem On / Off;

Modem UART

- RXD : Modem UART RX line;



- TXD : Modem UART TX line;
- RTS : Pin can serve several functions, based on PCB jumpers settings:
 - Modem UART RTS signal;
 - GPS receiver UART RX line;
- CTS : Pin can serve several functions, based on PCB jumpers settings:
 - Modem UART CTS signal;
 - GPS receiver UART TX line;

Modem Control and Status

- DTR : Modem DTR signal;
- DCD : Modem DCD signal;
- RI : Modem RI signal;
- STATUS : Pin can serve several functions, based on PCB jumpers settings:
 - Modem STATUS signal;
 - qJam interface QIO line;

I2C BUS

- I2C SDA : I2C Bus SDA line, connected to UID NVM chip and qJam interface;
- I2C SCL : I2C Bus SCL line, connected to UID NVM chip and qJam interface;
- Both lines are NOT connected to Modem I2C bus.

Minimal connection, power On / Off

To get Device fully functional, just part of lines to be used:

- 5VIN & GND (Device Power);
- ENABLE (Device Power On/Off Control : DC/DC On/Off);
- ON (Modem On/Off Control);
- RXD & TXD (Modem UART TXD & RXD lines);
- I2C SDA & I2C SCL (UID NVM & qJam interface).

To get Modem ON these steps to be done:

- Bring the power to 5VIN & GND pins;
- Turn ENABLE pin On (HIGH);
- Turn ON pin On (HIGH) for 1 sec;

- Turn ON pin Off (LOW);
- Check URC and AT Commands reply on Modem UART or check STATUS line HIGH level (if line connected);

To get Modem OFF these steps to be done:

- Turn ON pin On (HIGH) for 1 sec;
- Turn ON pin Off (LOW);
- Wait for “Power Off” UART message from Modem or check STATUS line LOW level (if line connected);
- Turn ENABLE pin Off (LOW);
- Remove the power from VIN & GND pins.

PCB Jumpers

Overview

We have developed qTop line devices to be flexible as possible to be used in various IOT solutions.

So, to achieve the maximum flexibility, the numbers of PCB jumpers have been implemented. Open and Closed PCB jumpers could be seen at picture below.



Pic.8. Open and Closed PCB jumpers

The Table 2 below lists all these PCB jumpers. There are two PCB jumper abbreviations used:

- Abbreviation “SC” – initially closed;

- Abbreviation “SO” – initially open.

SP1 PCB jumper is used for Modem FW upgrade.

Table 2

NoNo	Name	Description	Default State	Functional area
1	SC1	CTS / CTS_GPS_TXD bridge	Closed	GPS UART / GSM UART
2	SC2	RTS / RTS_GPS_RXD bridge	Closed	NVM
3	SC3	GSM_TXD / GSM_TXD_ESP32 bridge	Closed	GSM UART
4	SC4	GSM_RXD / GSM_RXD_ESP32 bridge	Closed	GSM UART
5	SC5	UID NVM Address Selection	Closed	UID NVM
6	SC6	GPS Antenna Power Enable	Closed	GPS
7	SC7	GSM_NET LED Enable	Closed	Modem Control & Status
8	SO1	GPS_TXD / CTS_GPS_TXD bridge	Open	GPS UART / GSM UART
9	SO2	GPS_RXD / RTS_GPS_RXD bridge	Open	GPS UART / GSM UART
10	SO4	GSM_TXD / GSM_TXD_ESP_RTS bridge	Open	GSM UART
11	SO5	GSM_RTS / GSM_TXD_ESP_RTS bridge	Open	GSM UART
12	SO6	GSM_RXD / GSM_RXD_ESP_CTS bridge	Open	GSM UART
13	SO7	GSM_RTS / GSM_RXD_ESP_CTS bridge	Open	GSM UART
14	SO8	GSM_DTR / GSM_DTR_EXT bridge	Open	Modem Control & Status
15	SO9	GSM_DCD / GSM_DCD_EXT bridge	Open	Modem Control & Status
16	SO10	GSM_RI / GSM_RI_EXT bridge	Open	Modem Control & Status
17	SO11	GSM_STATUS / GSM_STATUS_EXT bridge	Open	Modem Control & Status
18	SO12	qJam QIO / GSM_STATUS_EXT bridge	Open	qJam IO
19	SO13	GSM RI QINT/ QINT_EXT bridge	Open	Modem Control & Status
20	SO14	qJam QINT / QINT_EXT bridge	Open	qJam INT
21	SO15	VDD_RTC / VDD_RTC_EXT bridge	Open	Modem RTC
22	SO16	UID NVM Address Selection	Open	UID NVM
23	SO17	I2C SDA Pull-Up Resistor Enable	Open	I2C
24	SO18	I2C SCL Pull-Up Resistor Enable	Open	I2C
25	SP1	USB Boot Pin Power On	Open	Modem FW Upgrade

Initially Closed PCB jumper could be opened by cutting trace between jumper pads.
Open PCB jumper could be closed by soldering using iron's tip.

Picture below shows location of PCB jumpers.

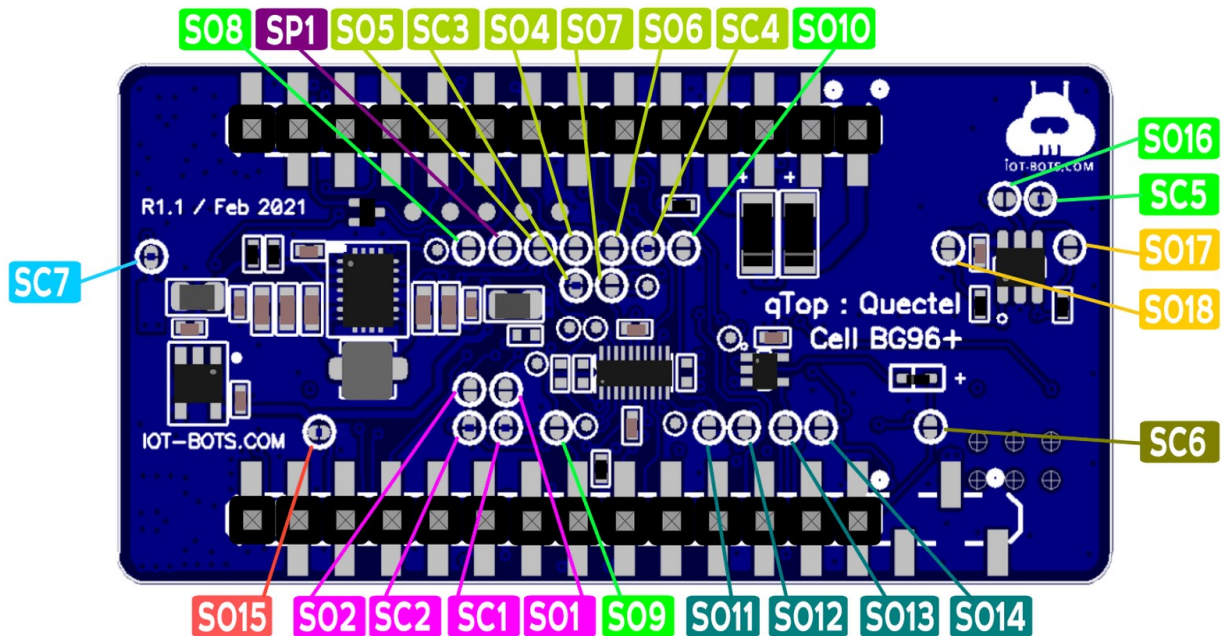

Pic.9. qTop BG9x LTE/GNSS AMC Shield PCB jumpers

Modem UART

RXD / TXD

To get Modem GSM RXD and GSM TXD lines available, these jumpers setting should be done:

GSM RXD : SC4 Closed / SO6 Open;

GSM TXD : SC3 Closed / SO4 Open;

RTS / CTS

To get Modem RTS and CTS lines available, these jumpers setting should be done:

RTS : SC2 Closed / SO2 Open / SO4 Open / SO5 Closed;

CTS : SC1 Closed / SO1 Open / SO6 Open / SO7 Closed;

GPS UART

To get Modem GPS RXD and GPS TXD lines available, these jumpers setting should be done:

GPS RXD: SC2 Open / SO2 Closed / SO4 Open / SO5 Closed;



GPS TXD: SC1 Open / SO1 Closed / SO6 Open / SO7 Closed;

Modem Control and Status

To get Modem control and status lines available, these jumpers setting should be done:

DTR : SO8 Closed;

DCD : SO9 Closed;

RI : SO10 Closed;

STATUS : SO11 Closed / SO12 Open;

qJam interface

To get qJam interface QIO line available, these jumpers setting should be done:

QIO : SO11 Open / SO12 Closed;

To get qJam interface QINT line available, these jumpers setting should be done:

QINT : SO14 Closed;

To get Modem RI signal to be available at qJam interface QINT line, these jumpers setting should be done:

RI_QINT : SO13 Closed;

RTC Voltage

To get Modem RTC pin connected to input RTC voltage, these jumpers setting should be done:

VDD_RTC : SO15 Closed;

I2C SDA & I2C SCL Pull-ups

If qTop shield is used with MCU controller boards with no I2C BUS pull-ups installed, to get bus working properly these jumpers setting should be done:

I2C SDA : SO17 Closed;



I2C SCL : SO18 Closed;

UID NVM chip Address

To change I2C BUS address of UID NVM chip installed these jumpers setting should be done:

“0xA4” : SC5 Closed / SO16 Open (Default settings);

“0xA6” : SC5 Open / SO16 Closed;

Network LED

To get Network LED Enabled or Disabled these jumpers setting should be done:

LED Enabled : SC7 Closed (Default settings);

LED Disabled : SC7 Open.

Test Points

qTop BG9x LTE GNSS AMC Shield has numerous amounts of test points to check device functionality. All of them are listed in Table 3 below.

Table 3

NoNo	Name	Description	Voltage Range	Functional area
1	TP1	GSM_TXD	0...3,3V	GSM UART
2	TP2	GSM_RXD	0...3,3V	GSM UART
3	TP3	GSM_RTS	0...3,3V	GSM UART
4	TP4	GSM_CTS	0...3,3V	GSM UART
5	TP5	GSM_DTR	0...3,3V	GSM UART
6	TP6	GSM_DCD	0...3,3V	GSM UART
7	TP7	GSM_RI	0...3,3V	GSM UART
8	TP8	GSM_STATUS	0...3,3V	GSM UART
9	TP9	USB_VBUS	0...5V	Modem USB
10	TP10	USB_DP	USB IO	Modem USB
11	TP11	USB_DN	USB IO	Modem USB
12	TP12	USB_BOOT	0...1,8V	Modem FW Upgrade
13	TP13	GND	0V	GSM UART
14	TP14	DEBUG_UART_TXD	0...1,8V	DEBUG UART
15	TP15	DEBUG_UART_RXD	0...1,8V	DEBUG UART

Pictures below show location of Test Points.

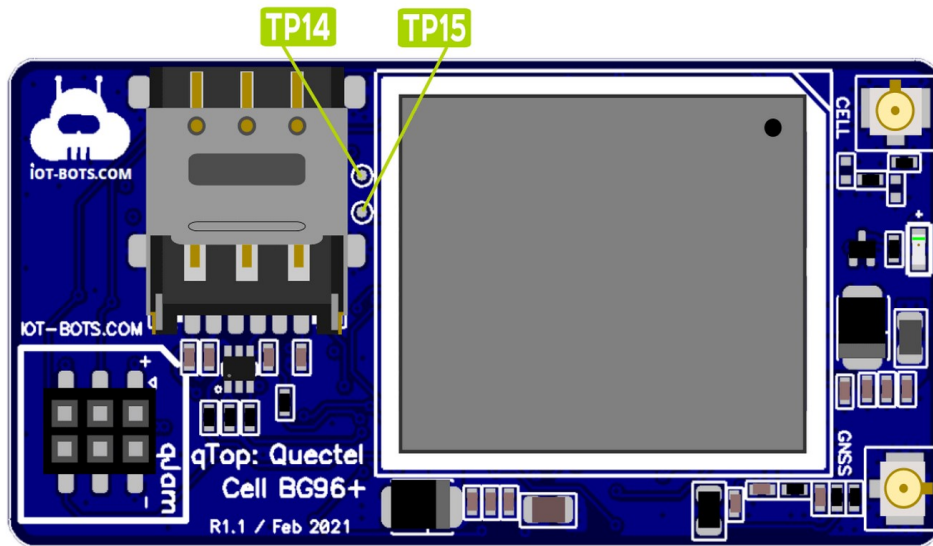

Pic.10. qTop BG9x LTE GNSS AMC Shield Test Points (Top)

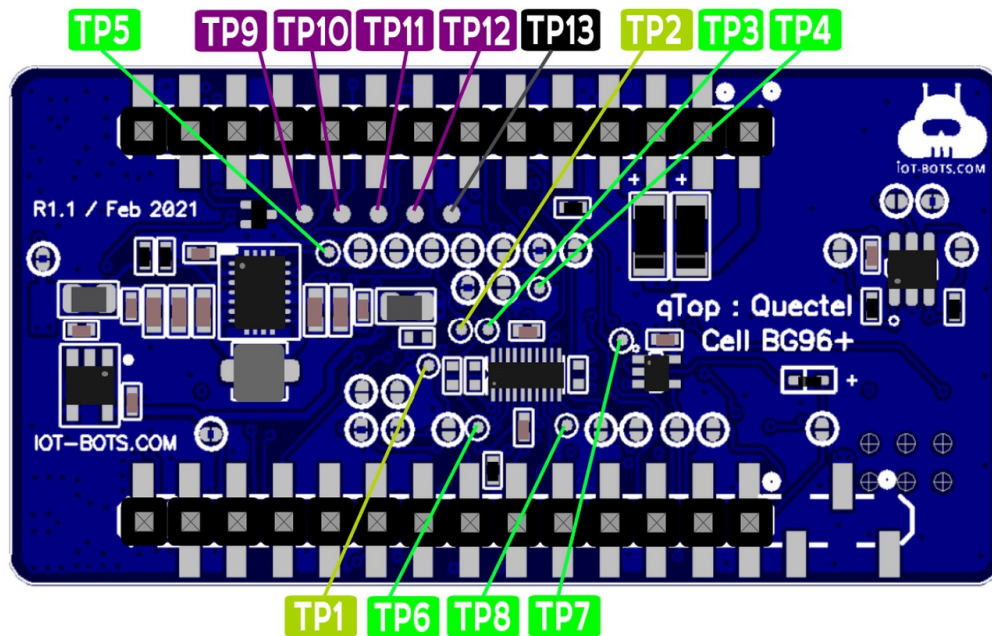

Pic.11. qTop BG9x LTE GNSS AMC Shield Test Points (Bottom)



Modem FW Update

Each qTop BG9x LTE/GNSS AMC Shield contains Test Points to upgrade Modem FW. To make FW upgrade these equipment setup steps to be done:

- These Test Points to be connected to Host (PC) USB interface:
 - TP9 : USB_VBUS
 - TP10 : USB_DP
 - TP11 : USB_DN
 - TP13 : GND
- SP1 PCB Jumper should be closed;
- After Device and Modem power on, Modem will be enumerated as serial port;
- Follow Modem FW Upgrade steps, described in appropriate app note document.

Test Points could be connected to the USB cable by soldering as at picture below or by pogo pins (<https://www.digikey.com/en/products/detail/mill-max-manufacturing-corp/0914-0-15-20-77-14-11-0/1147053>).

As soon as FW upgrade finished, SP1 PCB Jumper should be opened.

Getting Started

qTop BG9x LTE GNSS AMC Shields could be used with the most Arduino MKR IOT boards (Main Board).

To get board up and running these steps to be done:

- LTE and GNSS antennas **MUST** be connected to PCB u.FL connectors (directly or using u.FL-SMA adapter cables);
- SIM Card should be inserted;
- Appropriate FW should be flashed into Main Board;
- qTop Modem Shield should be plugged in right direction into appropriate connectors of Main board;
- If needed, qJam device could be plugged into Shield qJam connector;
- LiPol Battery or +5VDC 2.0+A power supply should be connected to a Main board.

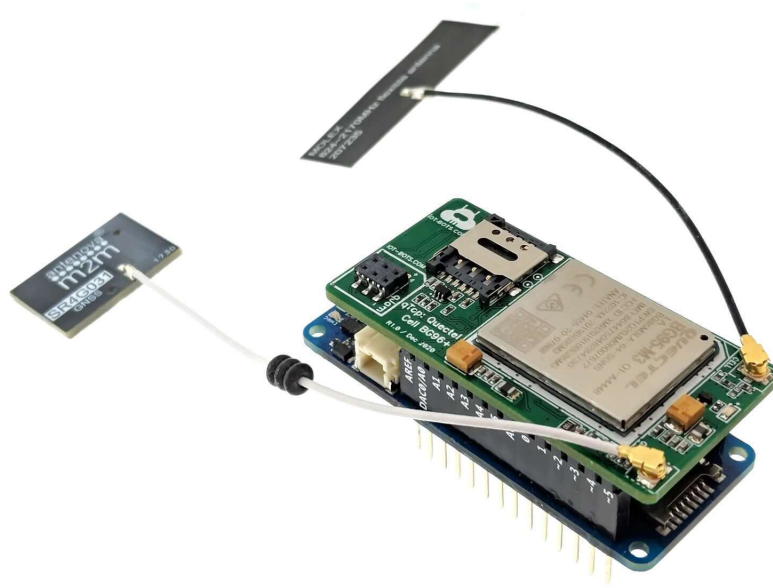

Pic.12. qTop BG95 LTE GNSS AMC Shield Setup (Arduino MKR Zero Board)

Several demos are implemented and published to get qTop Modem Shields up and running in a minute:

qTop BG95 AMC Arduino MKR Demo: <https://www.iot-bots.com/blogs/news/bg95-arduino-mkr-shield-and-thingsboard-dashboard-new-option-from-iot-bots-com>

qTop BG96 AFC Adafruit Feather ESP32 Demo: <https://www.iot-bots.com/blogs/news/get-your-nice-looking-iot-dashboard-in-a-minute-with-our-diy-iot-esp32-bg96-bme280-thingsboard-solution>

FCC & IC Compliance

If the device antenna is located farther than 20cm from the human body and there are no co-located transmitters then the Modem FCC/IC approvals can be re-used by the end product;

If the device antenna is located closer than 20cm from the human body or there are co-located transmitters, then the additional FCC/IC testing may be required for the end product (Modem FCC/IC approvals cannot be reused).



qTop BG9x LTE/GNSS AXC Shield are based on Quectel Module and use Quectel module's FCC & IC identification numbers.

Product SKU	FCC ID	IC ID
IBT-QTC-AMC-BG96	XMR201707BG96	10224A-201709BG96
IBT-QTC-AMC-BG95	XMR201910BG95M3	10224A-2019BG95M3

The FCC certificate could be found at the following link by searching for the FCCID listed above:

<https://www.fcc.gov/oet/ea/fccid>

The IC ID certificate could be found at the following link by searching for the IC ID listed above:

<https://sms-sgs.ic.gc.ca/equipmentSearch/searchRadioEquipments?execution=e1s1&lang=en>

Abbreviations

No	Abbreviation	Explanation
1	AFC	Adafruit Feather Compatible
2	AMC	Arduino MKR Compatible

Trademark notice

All referenced brands, product names, service names, and trademarks are the property of their respective owners.

Ordering info

No	Item	SKU
1	qTop BG96 LTE/GNSS AMC Shield	IBT-QTC-AMC-BG96
2	qTop BG95 LTE/GNSS AMC Shield	IBT-QTC-AMC-BG95