

DONGGUAN E-S MOTOR CO.,LTD

Precision Works, Professional Transmission

Tel : 86.135.3263.9595 | E-Mail : sales@e-smotor.com | www.e-smotor.com

997-24120 motor , 24V DC

Model	Voltage	No-load speed RPM	No-load current A	Rated speed RPM	Rated torque N.m	Output power Watt	Rated current A	Stall torque N.m	Stall Current A
997-24120	24V DC	12,000	1.6	11,000	0.5	120	12	5	20

60PG-997 planetary gear motor , 24V DC

Gear ratio	3.6	4.25	13	15	18	47	55	65	77	168	198	234	276	326
Gear stage	1	1	2	2	2	3	3	3	3	4	4	4	4	4
Gearbox length L (mm)	40.5	40.5	52	52	52	63.5	63.5	63.5	63.5	75	75	75	75	75
No-load speed (RPM)	3300	2820	920	800	666	255	220	184	155	70	60	50	42	36
Rated speed (RPM)	3000	2500	800	710	600	210	185	153	130	60	50	42	36	30
Rated Torque (N.m)	1.62	1.9	5	6	7	16	19	22	26	50	60	60	60	60
max. instantaneous allowable torque (N.m)	9	9	36	36	36	72	72	72	90	90	90	90	90	90



DONGGUAN E-S MOTOR CO.,LTD

Precision Works, Professional Transmission

Tel : 86.135.3263.9595 | E-Mail : sales@e-smotor.com | www.e-smotor.com

Encoder

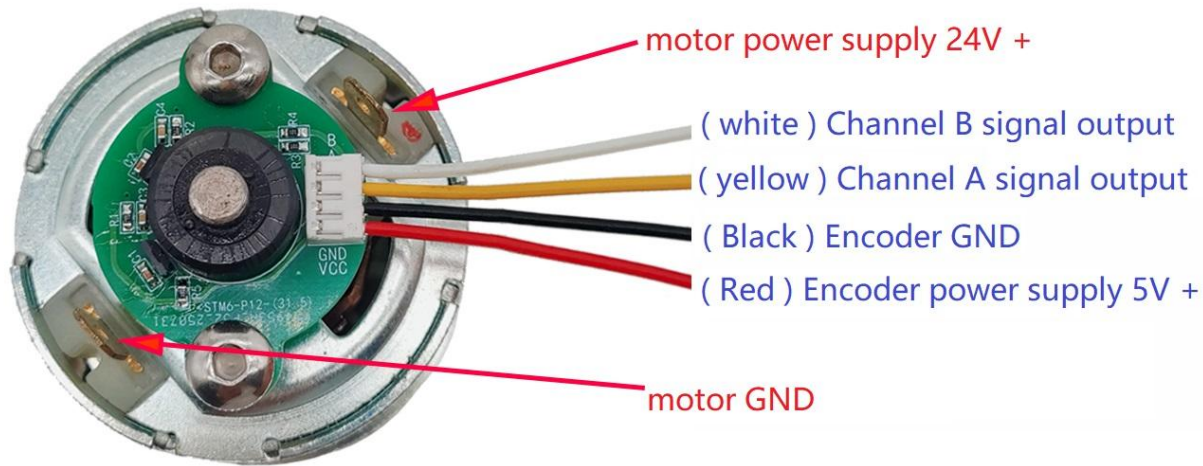

Encoder specification

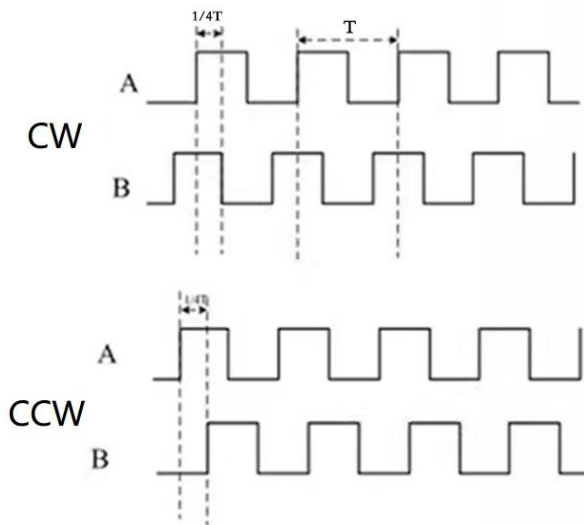

Item : Hall sensor Magnetic Encoder

Working Voltage : 5V

Operating Temperature : -20 to 80 °C

operating frequency : 20k Hz

Pulse : 14 PPR

Magnet disk size : 18 * 5 * 4 mm

Output signal:

A/B 2 square wave, 1/4 cycle difference



DONGGUAN E-S MOTOR CO.,LTD

Precision Works, Professional Transmission

Tel : 86.135.3263.9595 | E-Mail : sales@e-smotor.com | www.e-smotor.com