

## DS213 Mini Oscilloscope User Manual v1.1

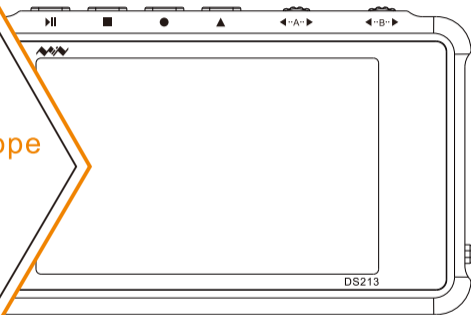

This user manual is based on DS213 DFU V3.73, APP V1.27.

# Contents

Important Safety Information	-----	P1
I. Overview	-----	P3
II. Interface Introduction	-----	P7
III. Getting Started	-----	P15
IV. General Inspection	-----	P23
V. Function Inspection	-----	P24
VI. Battery Disposal	-----	P25
VII. Technical Support	-----	P26

## Important Safety Information



- Read carefully all the following safety precautions to avoid personal injury and prevent damage to the device or any products connected to it. Failure to follow these safety instructions could result in personal injuries or risk of fire.



- Follow all the safety precautions to prevent potential risks. Avoid fire and personal injuries.
- Use proper power supply. Please use power supply specified for this product and certified for your country/district of use.
- Connect and disconnect properly. Do not connect or disconnect probe or test leads while they are connected to voltage source. Before you connect or disconnect current probes, please disconnect power to the circuit under test.
- Observe all the terminal ratings. To avoid fire or shock hazard, please do not measure signals above 40V. Please read the User Manual carefully to learn more about ratings before connection.



- Do not operate in a humid environment.
- Do not operate in a potentially inflammable/explosive atmosphere.
- Please keep the device surface clean and dry.

## Operating Environment

Operating Environment	Requirement	
Temperature	Operating Condition	+0°C to +50°C
	Non-operating Condition	-20°C to +60°C
Humidity	Operating Condition	High Temperature: 40°C to 50°C, 0% to 90%RH
		Low Temperature : 0° C to 40°C, 10% to 90%RH
	Non-operating Condition	High temperature: 40°C to 60°C, 5% to 95%RH
		Low temperature: 0° C to 40°C, 5% to 95%RH

## I. Overview

DS213 is a “5-track, 4-wave line” digital storage oscilloscope for general-purpose electronic engineering task and it is based on ARM Cortex M3 core. DS213 uses FPGA to manage external ADC's control and data cache mode. It provides 4 application partitions for loading and upgrading up to 4 different application firmware. It also has built-in 8MB USB flash drive for storing waveforms and upgrading system firmware.

### 1. Performance parameters

#### 1.1 Performance parameters

Maximum sampling rate: 100M Sa/s

Analog bandwidth: 15M

Analog input impedance: 1M $\Omega$

Coupling: AC/DC

Maximum input voltage:  $\pm 40V$ (X1 probe)

$\pm 400V$ (X10 probe)

Horizontal sensitivity: 100nS/Div–1S/Div(1–2–5 stepping)

Vertical sensitivity: 10mV/Div–10V/Div(1–2–5 stepping)

Standard digital channel input impedance: 100K $\Omega$

Max digital channel input voltage: +5V

## 1.2 Functionalities

Trigger type: Edge trigger, level trigger, pulse width trigger(See P10 for details)

Trigger mode: Auto, Normal, Single, Slow

Auto measurement: Frequency, Cycle, Duty, Positive Pulse Width, Negative Pulse Width, Vpp/  
Vrms/Vavg/Vmax/Vmin

Inbuilt signal Generator: 10Hz~8MHz square wave, 10Hz~20KHz sine wave/triangular wave/  
sawtooth wave

## 1.3 Product parameters

Storage: Inbuilt 8MB U disk storage for waveform data and images

Battery: Internal 1000mAh Lithium battery, external Micro USB port

Display: Color TFT LCD display (240X400 pixels)

Dimension: 99.5×59×13.5mm

## 2. Buttons and Interface

Shortcut functions: ▲ + ■ Save screenshot  
▲ + ■ Save system setting  
▲ + ● Auto calibration

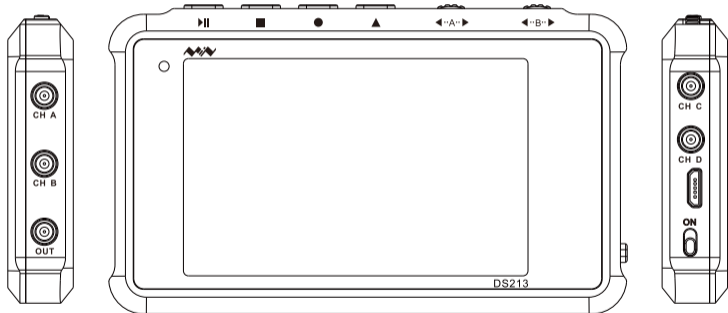

Button	Function
⏸	Run/Pause (K1 key)
■	Display Menu (K2 key)
●	Switch Channel (K3 key)
▲	Fn Combination Key (Hold this key and roll Encoder A to fast adjust data) (K4 key)
◀-A-▶	Adjust/Change Option
◀-B-▶	Cursor, movable from A to U
CH A	Analog Input Channel A
CH B	Analog Input Channel B
CH C	Analog Input Channel C
CH D	Analog Input Channel D
OUT	Waveform Output Channel
USB	Charging/Data Connection
ON	Power Button



## II. Interface Introduction

### 1. Channels and Menu Colors

Orange for common menu

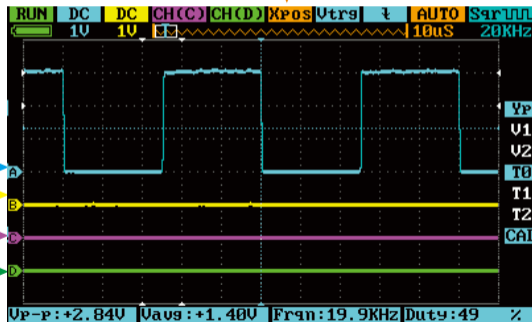

Blue for Channel A  
Yellow for Channel B  
Purple for Channel C  
Green for Channel D

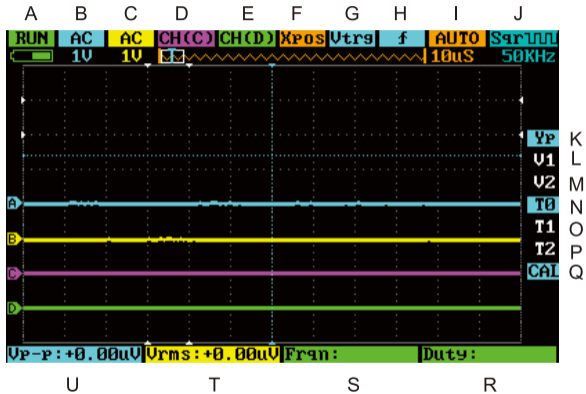

## 2.Home Screen Introduction



Menu	Icon	Item	Options
A	RUN	RUN/HOLD	(Operating status) Run/Pause
			Battery supply
B	AC	AC/DC/--/AC 10X/DC 10X	(Channel A) AC/ DC coupling/Hide/AC 10 times attenuation/ DC 10 times attenuation
		10mV-10V (1-2-5 sequence step) 0.1V-100V (1-2-5 sequence step) (10X attenuation)	Voltage value per grid
C	AC	AC/DC/--/AC 10X/DC 10X	(Channel B) AC/DC coupling/ Hide/AC 10 times attenuation/ DC 10 times attenuation
		10mV-10V (1-2-5 sequence step) 0.1V-100V (1-2-5 sequence step) (10X attenuation)	Voltage value per grid
D	CH (C)	CH(C)/(A+B)/(A-B)/ (C&D)/(C D)/ INV A/INV B/--	CH(C): Choose Channel C for input (A+B): Adding of waveforms of Channel A & Channel B (A-B): Subtraction of waveforms of Channel A & Channel B (C&D): AND operation of waveforms of Channel C & Channel D (C D): OR operation of waveforms of Channel C & Channel D INV A: Inversion of waveform of Channel A INV B: Inversion of waveform of Channel B Hide



Menu	Icon	Item	Options
E	CH (D)	CH (D)/REC_A/REC_B/ REC_C/REC_D/--	CH(D): Choose Channel D for input REC_A: Reload the last waveform saved in Ch_A REC_B: Reload the last waveform saved in Ch_B REC_C: Reload the last waveform saved in Ch_C REC_D: Reload the last waveform saved in Ch_D --: Hide
F	Xpos	Xpos	Choose waveform position: roll Encoder A to observe waveforms around triggering
G	Vtrg	Vtrg	Trigger line: roll Encoder A to adjust trigger voltage value, press Switch button "●" to choose channel
H		 ,  , <Vt, >Vt, <TL, >TL, <TH, >TH	Trigger mode: falling edge trigger/ rising edge trigger/ smaller than trigger/larger than trigger/ negative pulse width smaller than trigger/ negative pulse width larger than trigger/ positive pulse width smaller than trigger/ positive pulse width larger than trigger

Menu	Icon	Item	Options
I	AUTO 10uS	AUTO/NORM/SINGL/SLOW	Auto/Normal/Single/Slow Scan
		100nS—1S ( 1-2-5 stepping )	Timebase (x-axis voltage per grid)
J	Sqr  50KHz	Sqr/Sin/Tri/Saw ( Vpp= 3V )	(Waveform output) Square wave/ sine wave/triangular wave/sawtooth wave
		( Sqr)10Hz—8MHz	1-2-5 stepping for lower than 1MHz
		(Sin/Tri/Saw) 10Hz—20KHz	2-4-6-8 stepping for higher than 1MHz
K	Yp	Yp	Waveform position line: roll Encoder A to adjust position line, press Switch button “●” to switch
L	V1	V1	Cursor V1: Visual voltage upper limit, press Switch button “●” to display/hide
M	V2	V2	Cursor V2: Visual voltage lower limit, press Switch button “●” to display/hide

Menu	Icon	Item	Options
N	T0	T0	Choose waveform display window: roll Encoder A to choose waveform stored in different position to display in current window
O	T1	T1	Time measurement Vernier T1: Roll Encoder A to adjust Vernier T1's value, press switch button to display/hide
P	T2	T2	Time measurement Vernier T2: Roll Encoder A to adjust Vernier T2's value, press switch button to display/hide
Q	CAL	CAL	Manual calibration: roll Encoder A to lever calibration, press switch button "●" to switch time measurement area of channel A/B
R	Duty	TwH, TwL, $\Delta T$ , Frqn, Cycl, Duty	TwH: High level time of single cycle TwL: Low level time of single cycle $\Delta T$ : Time length of Vernier T1 and T2 ( $\Delta T=T1-T2$ ) Frqn: Signal Frequency Cycl: Signal Cycle Duty
S	Frqn		

Menu	Icon	Item	Options
T	Vrms: +0.00uV	Vavg, Vmax, Vmin, Vrms, Vp-p, $\Delta V$ , Vtrg, Vbat	Vavg: Average Voltage Vmax: Max Voltage Vmin: Min Voltage Vrms: Root-Mean-Square Voltage Vp-p: Peak-to-Peak Voltage $\Delta V$ : Voltage Value of Vernier V1 and V2 ( $\Delta V=V1-V2$ ) Vtrg: Trigger Line Voltage of X-axis Vbat: Battery voltage
U	Vp-p: +0.00uV		

### 3. Menu Introduction

Under home screen, press menu button “” to enter menu options; press menu button “” again to exit.



<b>Options</b>	<b>Functions</b>	<b>Operation</b>
SaveWav000	Save dat file to built-in U disk	Roll Encoder A to choose file number, press K3 to confirm
LoadWav000	Load dat file	Roll Encoder A to choose file number, press K3 to confirm
SaveBuf 000	Save buf file (sampling data in buffering area) to built-in U disk	Roll Encoder A to choose file number, press K3 to confirm
SaveCsv 000	Save csv file (export sampling data in buffering area) to built-in U disk	Roll Encoder A to choose file number, press K3 to confirm
Volume 0%~100%	Adjust buzzer volume	Roll Encoder A to adjust volume
LcdBk 10%~100%	Adjust backlight brightness	Roll Encoder A to adjust backlight brightness
PwrDnT Off~60m	Adjust standby time	Roll Encoder A to adjust standby time



### III. Getting Started

#### 1. Operation Techniques

- 1) When noise and ripple waves need to be observed with signal accessed, AC coupling should be selected;
- 2) Vernier V1 and V2 can be used to measure the voltage difference between any two points;
- 3) Vernier T1 and T2 can be used to measure the time difference between any two points;

#### 2. Application Cases:

##### Case 1. Measure a simple signal

To observe a certain unknown signal, rapidly show and measure its frequency and peak value.

##### Operating steps:

- 1) Connect the ground wire, and connect the probe of Channel A (or Channel B) to the measured point of the circuit;
- 2) Set Channel A (or Channel B) as "AUTO" mode and "DC" coupling, adjust (horizontal) time scale and (vertical) voltage scale to present a clear signal display;

- 3) Adjust "Vtrg" to present stable signal display;
- 4) Select measuring data, such as Vpp (peak-to-peak voltage), Vavg (average voltage), FRQ (frequency), etc.

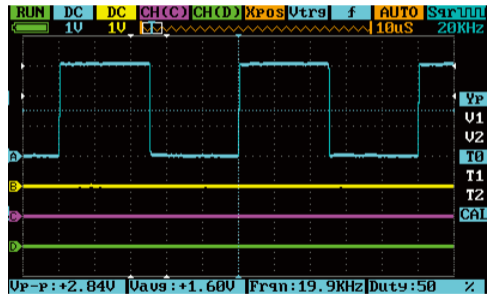

See the following picture for measurement display:



## Case 2. Capture single signal

The advantage and feature of digital oscilloscope includes conveniently capturing aperiodic signals like pulses and burrs. If a certain single signal is captured, prior knowledge is needed before setting trigger level and trigger edge. For example, if the pulse is a TTL level logic signal, the trigger level should be set as "2V", trigger edge as "rising edge". If the condition of measured signal is uncertain, common trigger models can be adopted first to observe so as to determine specific triggers.

### Operating steps:

- 1) Connect the probe of Channel B to the measuring point of the circuit;
- 2) Set the trigger: set position H as " " (rising edge trigger), position I as "SINGL"(single trigger), and position C trigger as "AC" (AC coupling);
- 3) Adjust horizontal time base and vertical gear to proper range;
- 4) Adjust G "Vtrg" and select proper trigger level;
- 5) Press " " run button and wait for the appearance of signals that caters to trigger conditions. If a certain signal reaches the set trigger level, it will be sampled and then showed on the screen.

This function can be used to capture the occasional events, such as large amplitude sudden burrs: set the trigger level right higher than normal signal, press " " button then wait. When burrs occur, DSO will automatically trigger and record the waveforms around the occurrence for observing. See the picture below.

This function can be used to capture the occasional events, such as large amplitude sudden burrs: set the trigger level right higher than normal signal, press "▶||" button then wait. When burrs occur, DSO will automatically trigger and record the waveforms around the occurrence for observing. See the picture below.

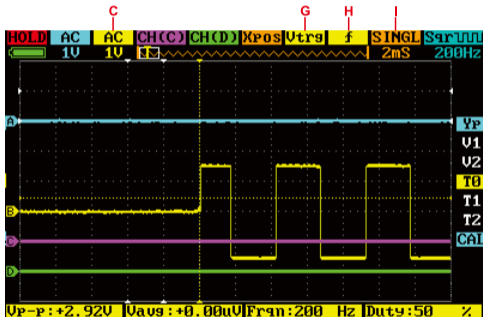

### Case 3. Use a Vernier to measure signal

Vernier can be used to rapidly measure waveforms in terms of time and voltage.

#### A. Measure the period of the third peak of signal source

##### Operating steps:

- 1) Roll Encoder B to move cursor to position O (T1);
- 2) Roll Encoder A to place Vernier T1 to the second peak of the signal;
- 3) Roll Encoder B to move cursor to the position P (T2);
- 4) Roll Encoder A to place Vernier T2 to the third peak of the signal;

Conclusion:  $\Delta T = 50\mu\text{s}$  is the period of the third peak.

#### B. Measure the peak-to-peak voltage of signal source

##### Operating steps:

- 1) Roll Encoder B to move cursor to position L (V1);
- 2) Roll Encoder A to place Vernier V1 to the peak of signal;
- 3) Roll Encoder B to move cursor to position M (V2);
- 4) Roll Encoder A to place Vernier V2 to the trough of signal;

Conclusion:  $\Delta V = 3.20\text{V}$  is the peak-to-peak voltage of signal.

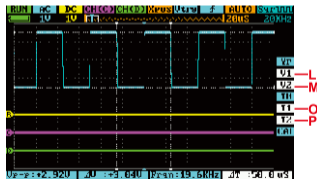

## Case 4. Waveform Comparison

REC\_A function in position D can be used to compare signal waveforms.

### Operating steps:

- 1) Input a known waveform signal in Channel A, press button "■", select "SaveWav 001", and press button "●" to save the waveform, see following picture;

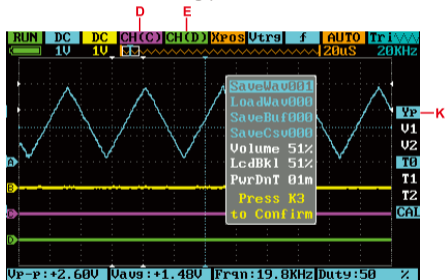

2) Input the waveform signal that is to be compared in Channel A, select "REC\_A" in position E, press button "●" to select "LoadWav001", see following picture;

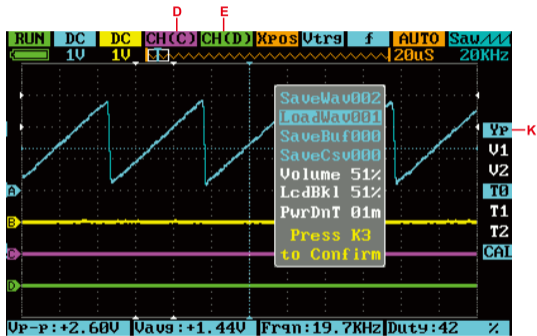

3) Move "Yp" in position K to adjust the horizontal line and then compare the waveforms.  
See following picture.

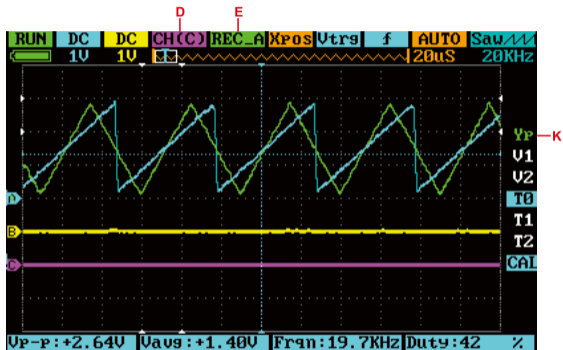



## IV. General Inspection

When you get a new DS213 Mini Oscilloscope, you are advised to inspect the product by the following steps.

- Inspect damages caused by shipping. If the packaging carton is seriously damaged, keep the package until the oscilloscope & accessories pass the electrical and the mechanical test.
- Inspect the product. Please contact the seller if the following problems occur:
  - 1) product surface is damaged,
  - 2) product doesn't work properly,
  - 3) product does not pass performance test.

If the damage is resulted from shipping, please keep the package and contact the seller for repair or exchange.

## V. Function Inspection

Take a quick function inspection of DS213, to make sure it works normally. Please follow these steps:

1. Switch on the power button, enter the home page of the DSO.
2. Input a standard signal (eg. Square wave 20KHz,  $V_{pp}=5V$ ) into oscilloscope's "CH A" with a probe:
  - 1) Set the tap on the probe to X1, insert the probe's MCX plug to "CH A", and insert the pin of probe into "OUT";
  - 2) Check if there is a distortion of measurement and standard, calibrate if different. Check the other channels with the same method.

## VI. Battery Disposal



FCC compliance statement

This device is complied with the regulation in the 15th part of FCC regulation.

Operation is subject to the following two conditions:

- (1) This device may not cause harmful interference, and
- (2) This device must accept any interference received, including the interference that may cause undesired operation.



The CE mark is a registered trademark of European Community. This CE mark shows that the product complies with all the relevant European Legal Directives.



This product contains batteries and/or recyclable electronic parts. Please do not dispose of the product together with household garbage. Please handle it according to your local laws and regulations.

## VII. Technical Support

To upgrade the firmware of oscilloscope, please carry out the steps below:

1. Visit [www.miniware.com.cn](http://www.miniware.com.cn), download the applicable firmware appropriate to oscilloscope to your PC.
2. Hold button “▶||” and turn on DS213, to enter DFU mode for upgrade.
3. Use USB data cord to connect DS213 to your PC, and a removable hard disk named “DFU X.XX” will appear on your PC. Copy the hex firmware to the root directory of that disk. After the extension of the firmware changes from “.hex” to “.rdy”, restart DS213. Then the upgrading process is completed.

