

HMC-20

Human Machine Controller

Configurable HMI interface

Version date 23/07/2024



Main features HMC-20

7" or 3,4" RGB TN TFT display

24bit 800x480px 1000 cd/m²

4x5 keypad interface

PWM backlight 10V/300mA

10 digital I/O

GPU 256/65K colors

Internal font ROM 8x16dots

RTC with external low power Xtal

Real time command interpreter

Rotation function 90° step

Internal widgets

SD-card interface

USB2.0 port ESD protected

Font ROM chip 150 countries

64Mb serial NOR flash with HMAC

Piezo electric buzzer

Resistive or capacitive touch

interface

3V battery holder for RTC

User application board connector

High efficiency power supply

Demo code

UAB-23

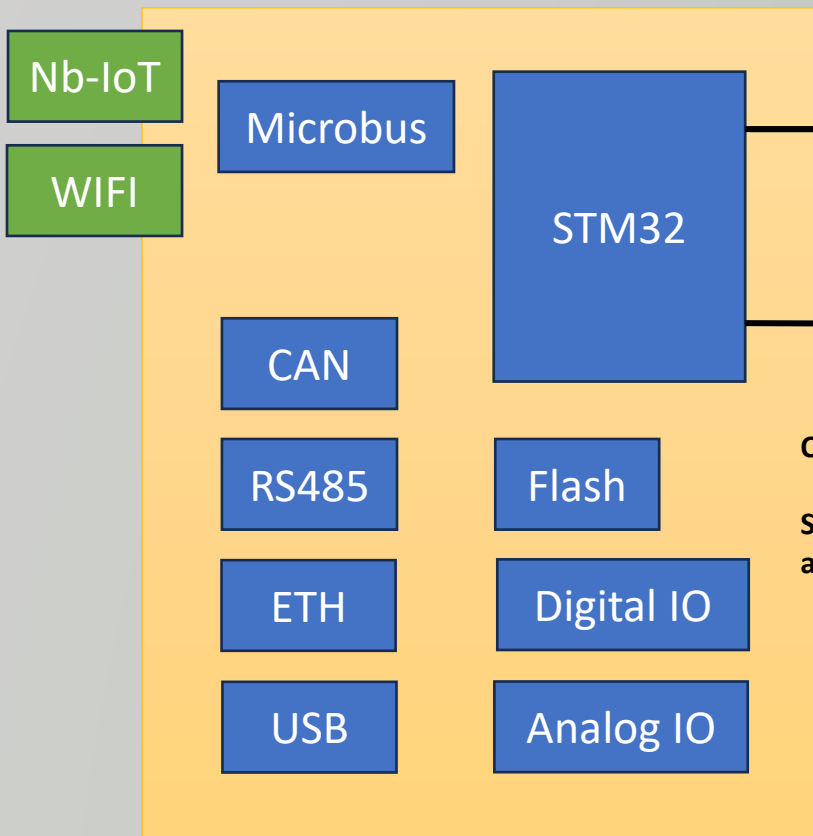

- Developed by customer with specific interfacing
- Generic board delivered by Saleconix

SD card access

SPI

UART

Open protocol

Same commands as widget events

HMC-20

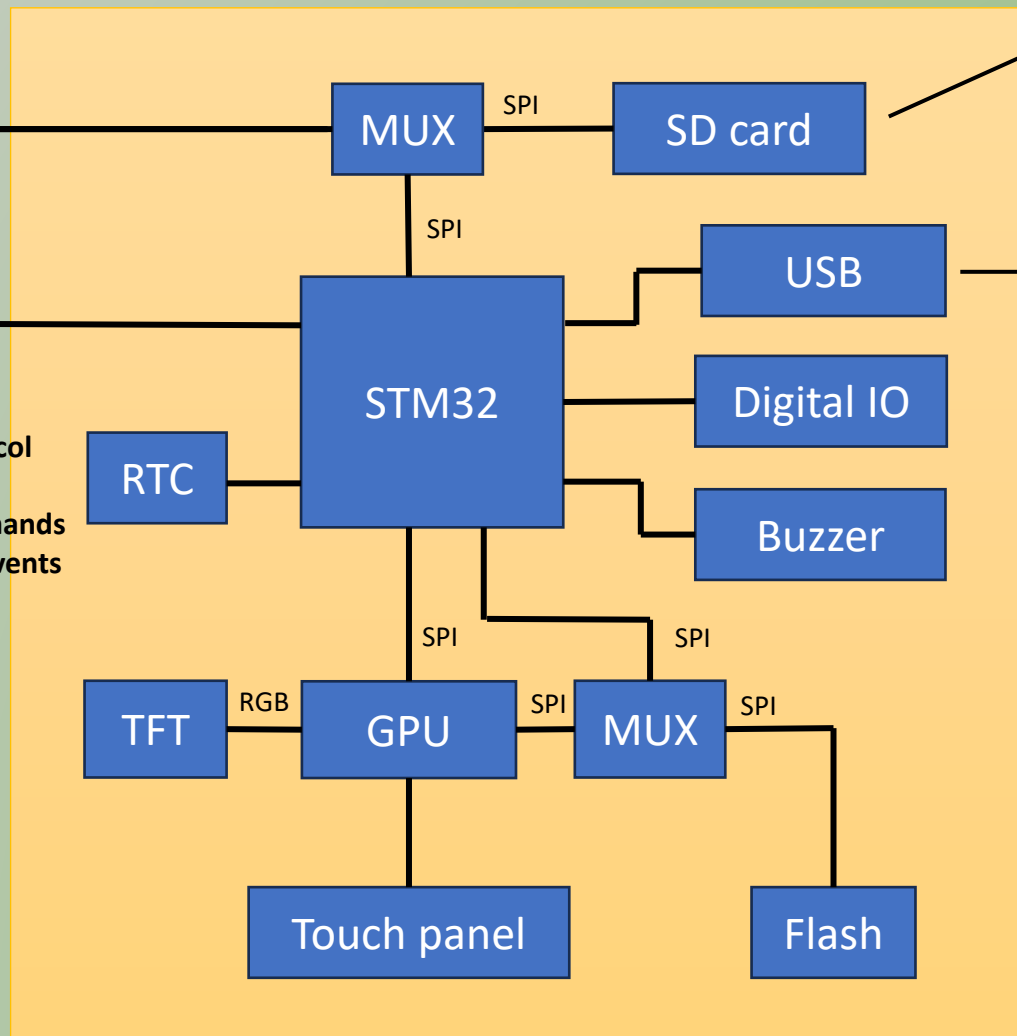

Contains

- BMP/JPG (widgets)
- GUI layout and interactions
- Extra fonts
- firmware update
- logging

After connection:

- SD card available as drive
- UART as debug interface
- Firmware updates

HMC-20 can also be used autonomously (e.g. driving LED/relay)

UAB-23

HMC-20

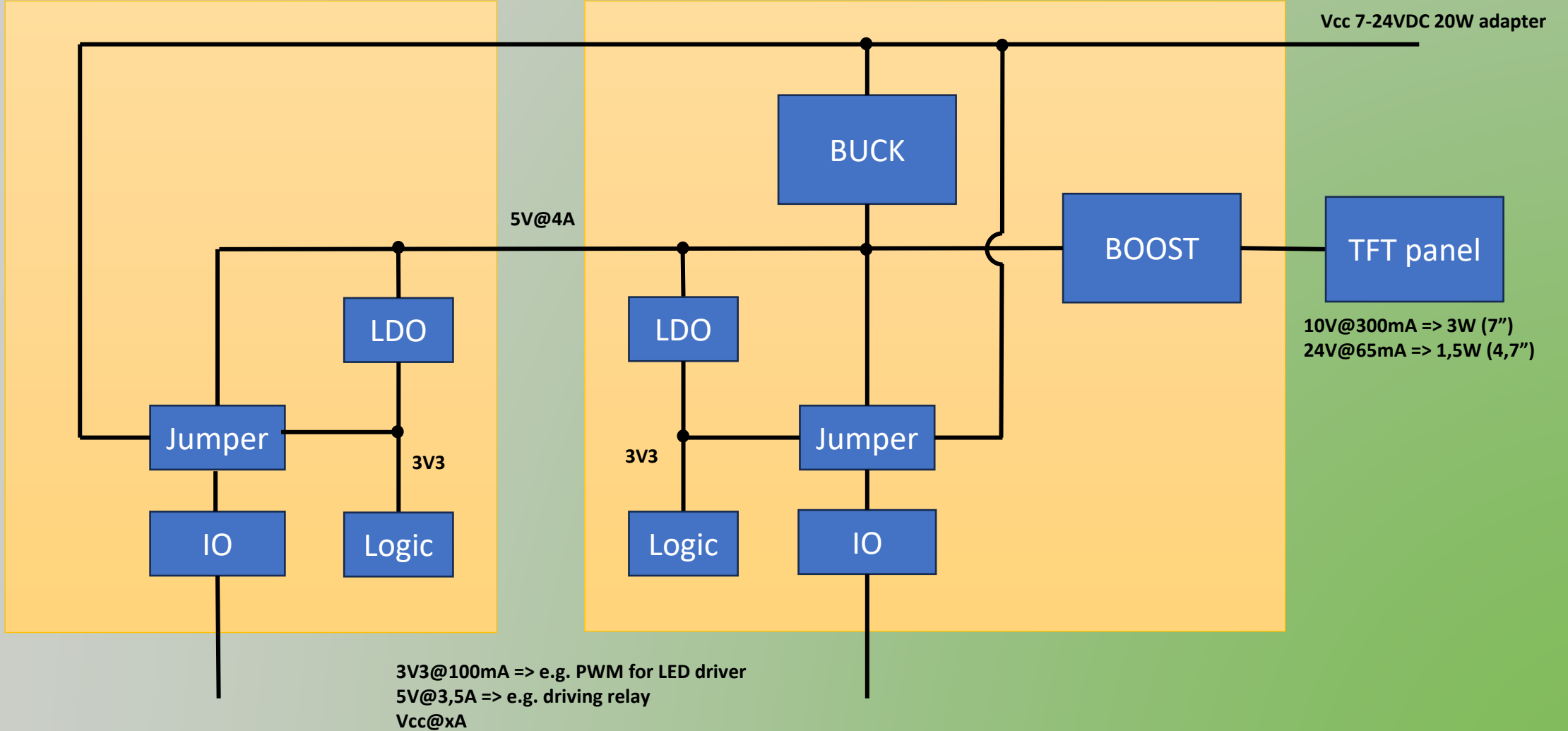

HMC-20

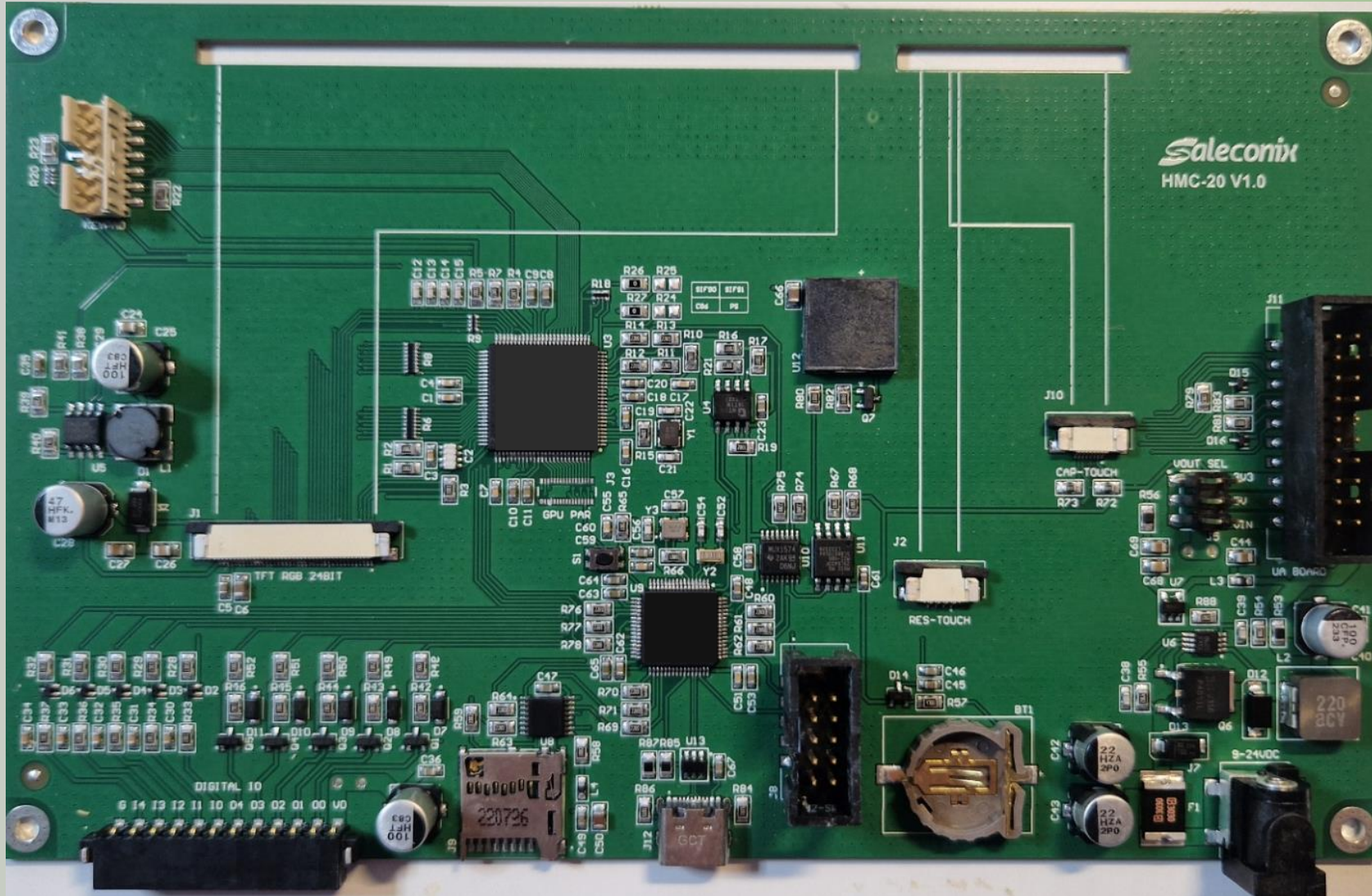

Casing

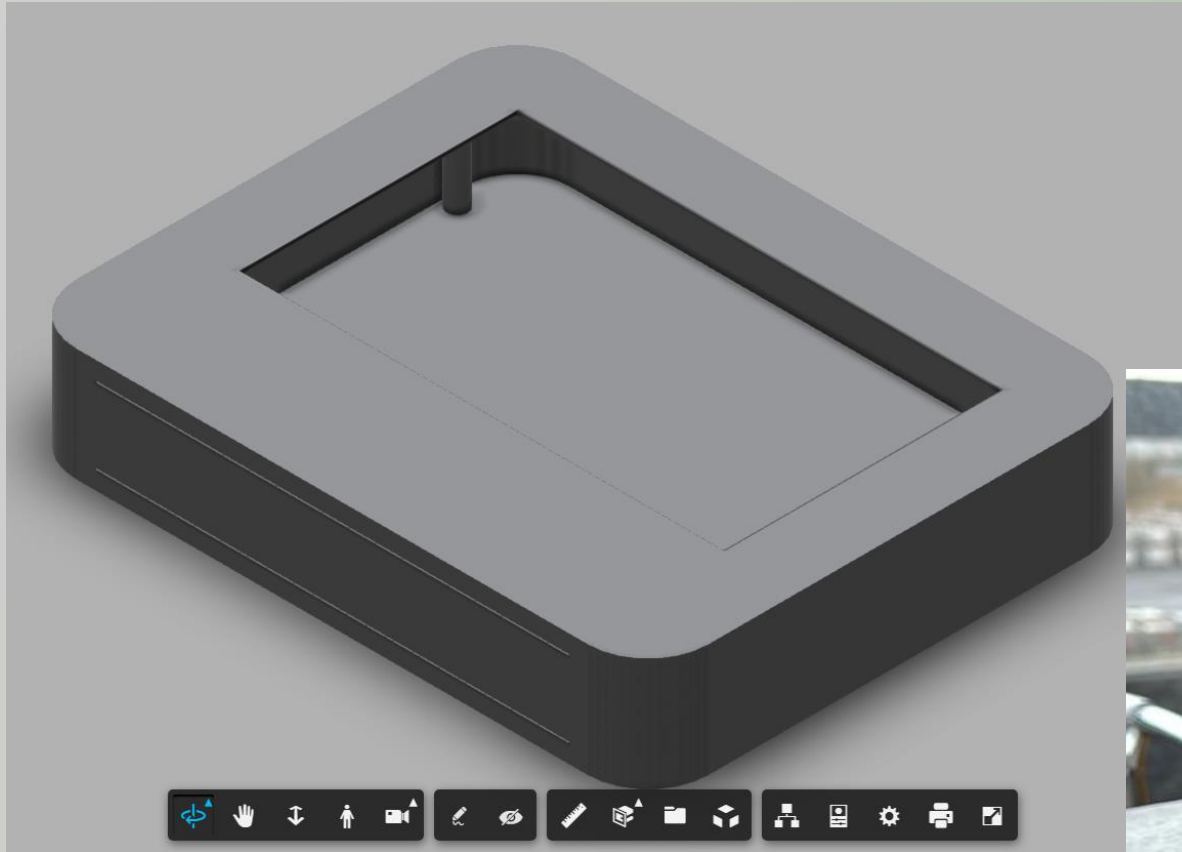

Update widgets and layout

1: SD card contains new sources and “copy.txt” dummy file

2: After startup all the data will be copied to internal Flash and dummy file will be deleted

3: SD card is no longer necessary as long as no layout changes are needed

Advantages:

- fast access with internal flash
- SD card can be omitted when updating is not necessary
- SD card can be re-used for different modules

Capacitive versus resistive TFT

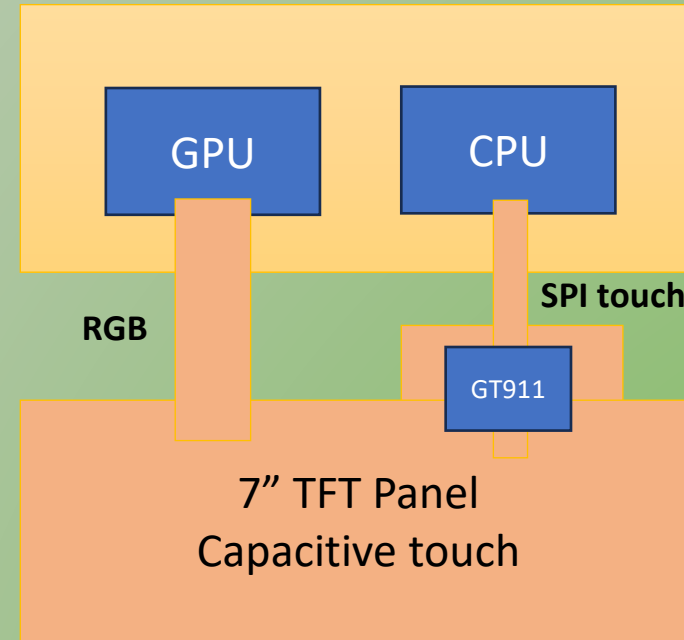
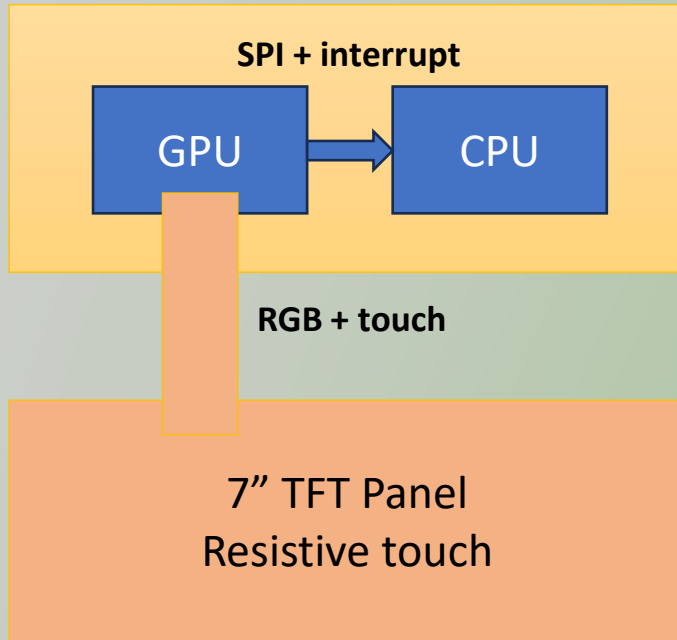

Widgets and attributes

Category	Widget	ID	Representation	Behavior	Events	
Visual	Page	Name/type	Level	Active	Touch: press, release, up, down, left, right	
	Button		Background	Border (type/color)		
	Led		Image	Sound (type/onoff)		
	Progressbar		Color	Visibility		
	Textual		Location	Coordinate system		
Non visual	Timer		Size	Clockpart	Start, Stop	Run out
	Pincode					Pass, Fail Savesuccessfull
	Function					Execute
	Clock					Set time/date

Level: foreground – background

Coordinate system: center - corner

Page: silent update mode → render after modifying widgets

All attributes and properties can be changed by commands

Real time interpreter example

Performs predefined actions in a random order. Can be as widget events or sent by serial port. There are three predefined forms:

Property assign type A: `[pagename].[widget].[propname]=[property]`

Property assign type B: `[pagename].[propname]=[property]`

Command type: `[command] [argument]`

Example:

```
okbutton.setTouchPressEvent(  
    "code.unlockkeypad.cmd='exe'\n" // Unlock the keypad  
    "code.enter.act=true\n"       // Unlock the enter button  
    "code.crosshome.act=true\n"   // Unlock the cross home button  
    "code.ok.vis=false\n"        // Make the text 'ok' invisible  
    "code.pincodesaved.vis=false\n" // Make the text 'pincodesaved' invisible  
    "code.popup.vis=false\n"     // Make the green popup window invisible  
    "page 'code'"                // Redraw the code page  
);
```

3,4 inch display in commercial case

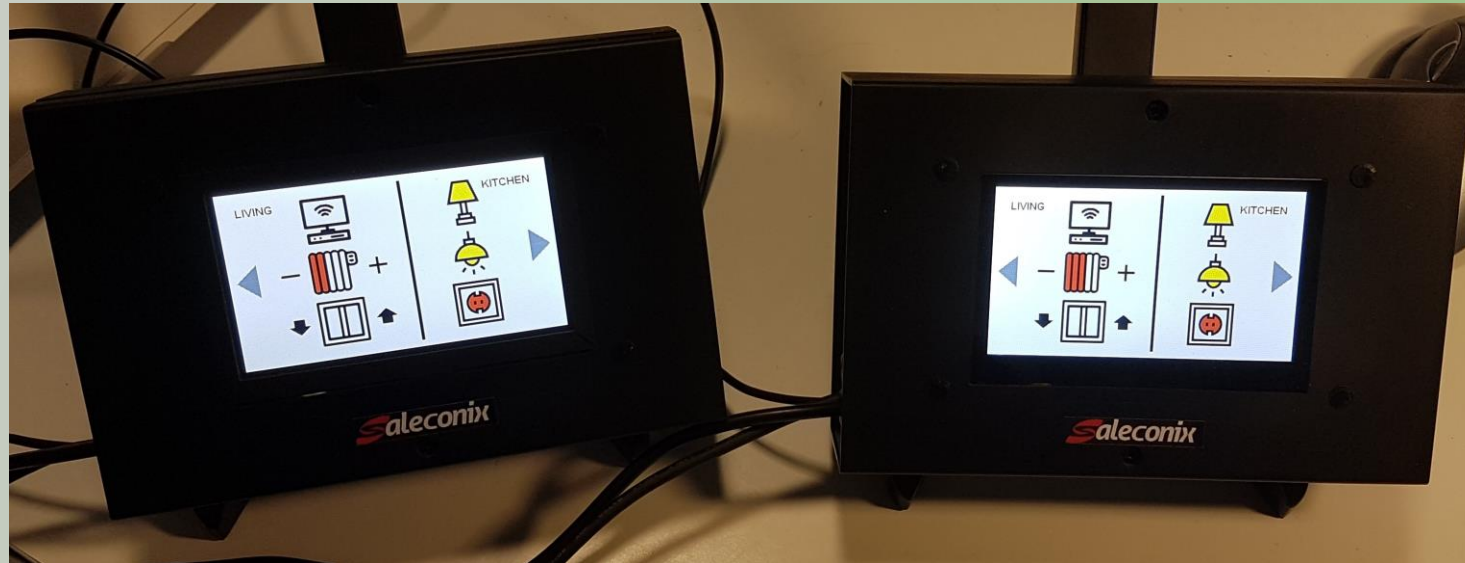

Saleconix company profile

Hardware design

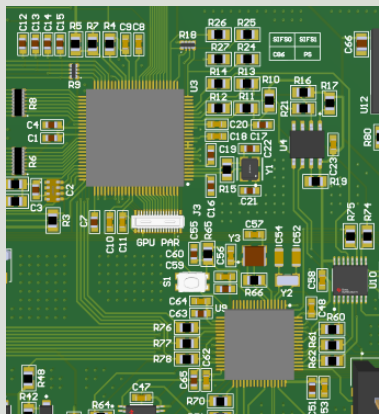
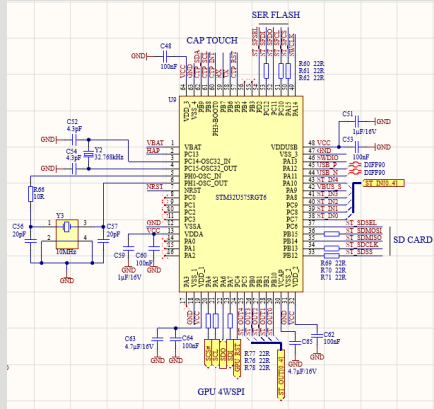

PCB prototyping

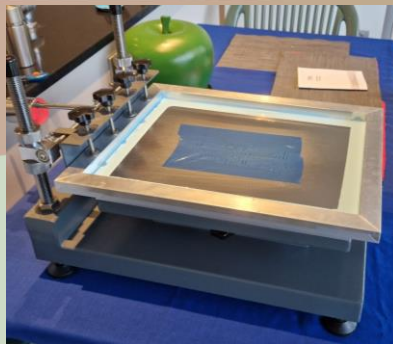
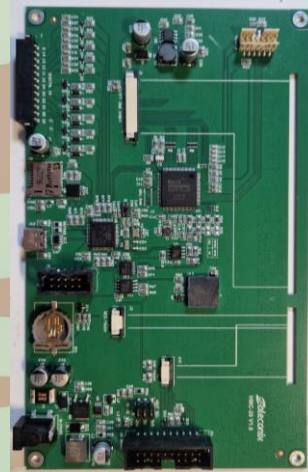

Verification and testing

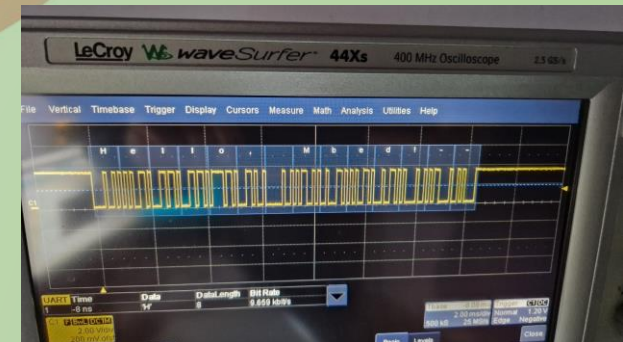
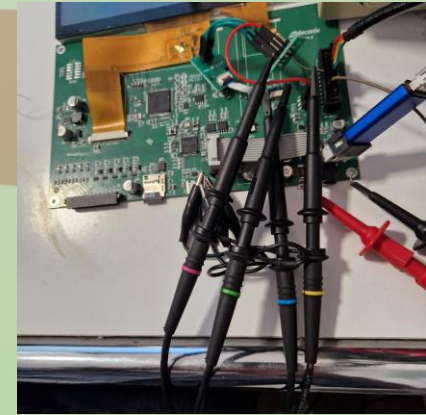

Saleconix company profile

Firmware development

```
4 #define MODULE "WIDGET_VIS"
5 //0:NONE 1:ERROR 2:WARNING 3:INFO 4:FINE
6 #define LOGLEVEL 2
7 #include "logging.h"
8
9 WidgetVisibleType::WidgetVisibleType(const char* objName, uint16_t type)
10 : Widget(objName, type, _status(noback), _x(0), _y(0), _w(0), _h(0), _wext(0), _hext(0),
11 _bco(0), _bcoset(false), _img(0), _imgset(false), _lcd(nullptr), _active(true), _sound(true),
12 _level(0), _visible(true), _cornercoords(false), _bordercolor(0), _border(false),
13 _touchReleaseEvent(nullptr), _touchMoveDownEvent(nullptr),
14 _touchMoveLeftEvent(nullptr), _touchMoveRightEvent(nullptr), _touchMoveUpEvent(nullptr) {
15     _isVisible = true;
16     if (!_tickerattached) {
17         _ticker.attach([&](_queue->call(tickerHandler));), 1s);
18         _tickerattached = true;
19     }
20 }
```

EMC analysis

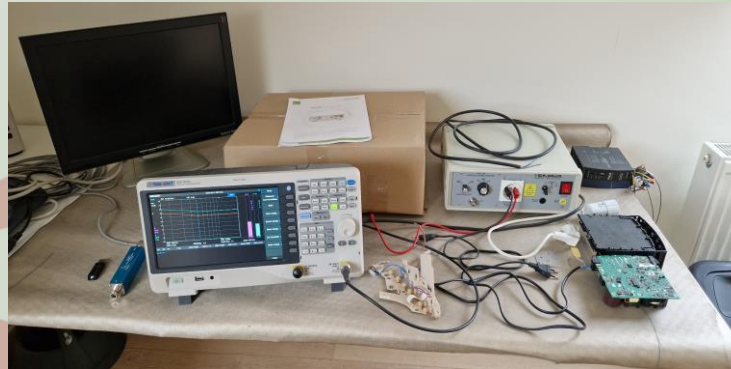

Mechanical design 3D printing

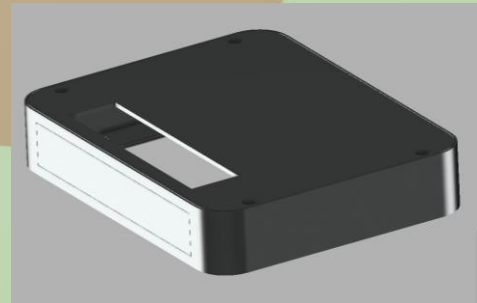

Production

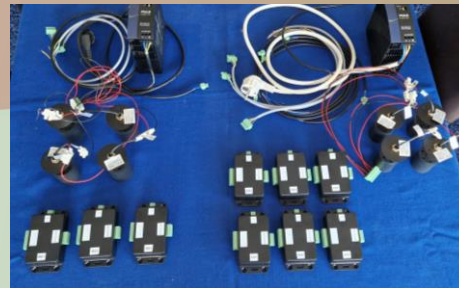



Additional information?

info@saleconix.be