



INSPIRE-ROBOTS

PRODUCT SELECTION GUIDE

Micro Linear Servo Actuator | The Dexterous Hands | Electric Gripper

Web: en.inspire-robots.com

E-mail: sales@inspire-robots.com

Phone: +86 13161665075

Address (Beijing): chuangxingongchang A3-4,NO.69,yangzhuang street,shijingshan District,Beijing,China.

Office (Shenzhen): Room 506, Building 1, Phase 1, Shenzhen Software Park, Nanshan District, Shenzhen,China.



ABOUT INSPIRE ROBOTS

Smaller and Higher-precision Motion Control Experts

Beijing Inspire Robots Technology Co., Ltd., established in May 2016, is a high-tech company focusing on the R & D manufacturing of micro high-precision motion parts. The main products include Micro Linear Servo Actuator and Dexterous hands, which have unique advantages in micro-size, high precision and force control. Products are widely used in robotics, new energy, 3C electronics, semiconductors and biomedical fields.

Products and Application

Inspire Robots' products can meet the demand in the fields such as biomedical, precision manufacturing, aerospace, education and scientific research, with an emphasis in micro servo motion and precision force control.

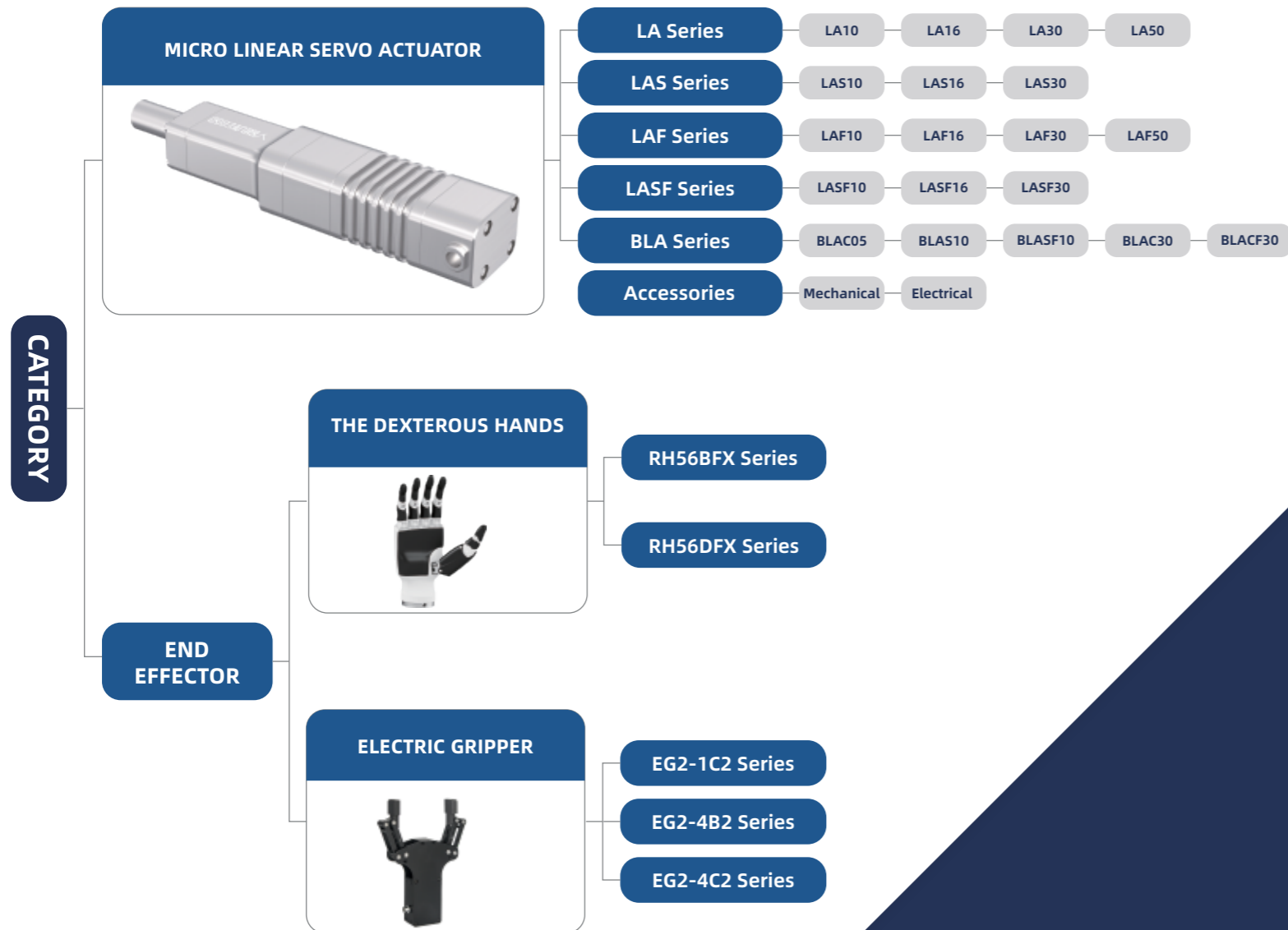

CATALOG

01/ About Inspire Robots	01
02/ Micro Linear Servo Actuator	03
Series	05
LA Series	07
LAS Series	15
LAF Series	21
LASF Series	25
BLA Series	28
Accessories	33
03/ The Dexterous Hands	35
04/ Electric Gripper	38

MICRO LINEAR SERVO ACTUATOR

Micro Linear Servo Actuator is a small integrated system combining core-less motor, precision planetary reducer, position sensor, precision screw mechanism and closed-loop control system in a single package. Its compact dimensions, large load capacity, and high precision at any point throughout its stroke range enables it to act as a core component in electromechanical systems such as robots, medical equipment, and industrial equipment. A built-in absolute position sensor enables the retention of position information even during a power loss, without the need for a reference point.

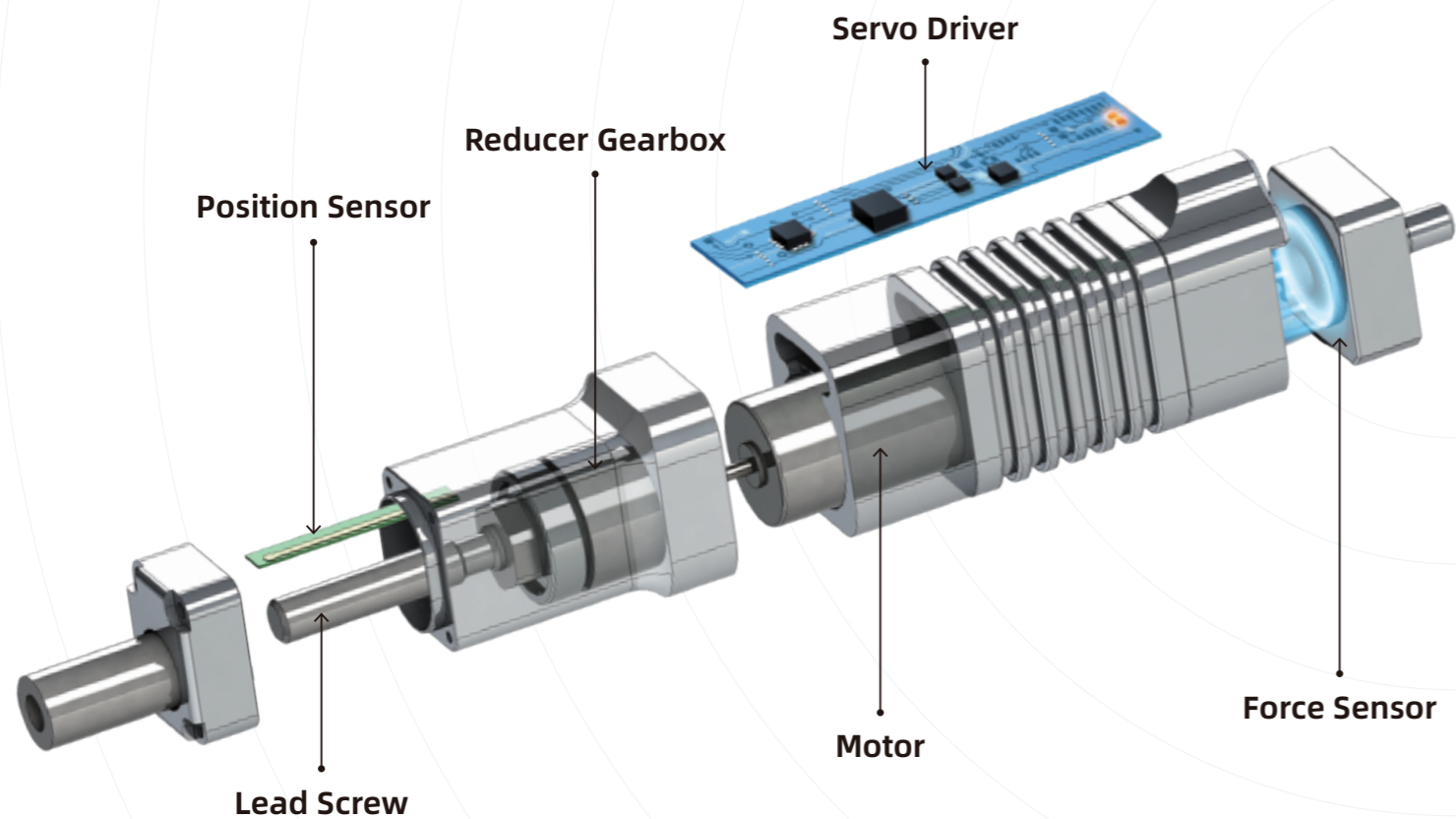

APPLICATIONS



ROBOTIC



Humanoid Robot



Bionic Robot



Surgical Robot



Teleoperation Robot



Dexterous Hands

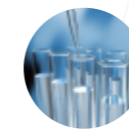

BIOMEDICAL INSTRUMENT



Minimally Invasive Surgical Instrument



Aesthetic Medicine Instrument



In-Vitro Diagnostics



Rehabilitation Equipment / Exoskeleton



Laboratory Automation



AUTOMATED INDUSTRY



New Energy



3C Electronic Equipment



Semiconductor Equipment



Optical Device



Auto Industry Equipment



3D Printing



Other Precise Instrument



AEROSPACE



Aircraft



Manned Spacecraft



EDUCATION AND SCIENTIFIC RESEARCH

Controller Integrated

Force Control (Force Control Model)

Small Size

High Precision

High Power Density

Micro Linear Servo Actuator

Series Introduction

LA Series

Tandem placement of motor and screw structure.

Advantages: Slender appearance, small cross-section, light weight.

LAS Series

Parallel placement of motor and screw structure.

Advantages: Compact dimensions, light weight.

LAF Series

Adding integrated force sensor on the LA series basis.

Enabling real time push rod force detection and control.

LASF Series

Adding integrated force sensor on the LAS series basis.

Enabling real time push rod force detection and control.

BLA Series

BLA Series Micro Linear Servo Actuator integrates brushless motor and planetary roller screw. The drive control system includes FOC control algorithm, with four closed-loop controls of current, speed, position and force output.

BLA series is mainly used in 3C automation, semiconductor and new energy industry, and is suitable for tooling fixtures, electric fixtures, wafer handling, circuit board welding testing, microfluidic valves. etc.



LA10 Series

Micro Linear Servo Actuator

Model Instruction

Series	Speed Level	Mechanical Interface	Electronic Interface	Model code
LA10	02	1	D	LA10-021D
Stroke	02 03 07 09	1-Standard Interface 2-Ear Interface 3-Octagonal Interface	D-LVTTL Serial port P-PWM Serial port	

Standard Parameters

Stroke	Weight	Operating Voltage	Repeatability	Operating Temperature Range	Quiescent Current	Peak Current	IP level
10mm	21g	DC8V±10%	±0.02mm	-10°C~+60°C	0.02A	2A	IP40

Speed Levels and Associated Parameters

Speed Level	Maximum Force	Locked-Rotor Force	Maximum Self-Locking Force	No-load Speed	Full Load Speed	No-Load Current
02	70N	100N	100N	18mm/s	8mm/s	0.2A
03	56N	80N	100N	36mm/s	16mm/s	0.24A
07	42N	60N	50N	50mm/s	21mm/s	0.5A
09	21N	30N	38N	70mm/s	36mm/s	0.5A



Standard Interface



Ear Interface



Octagonal Interface

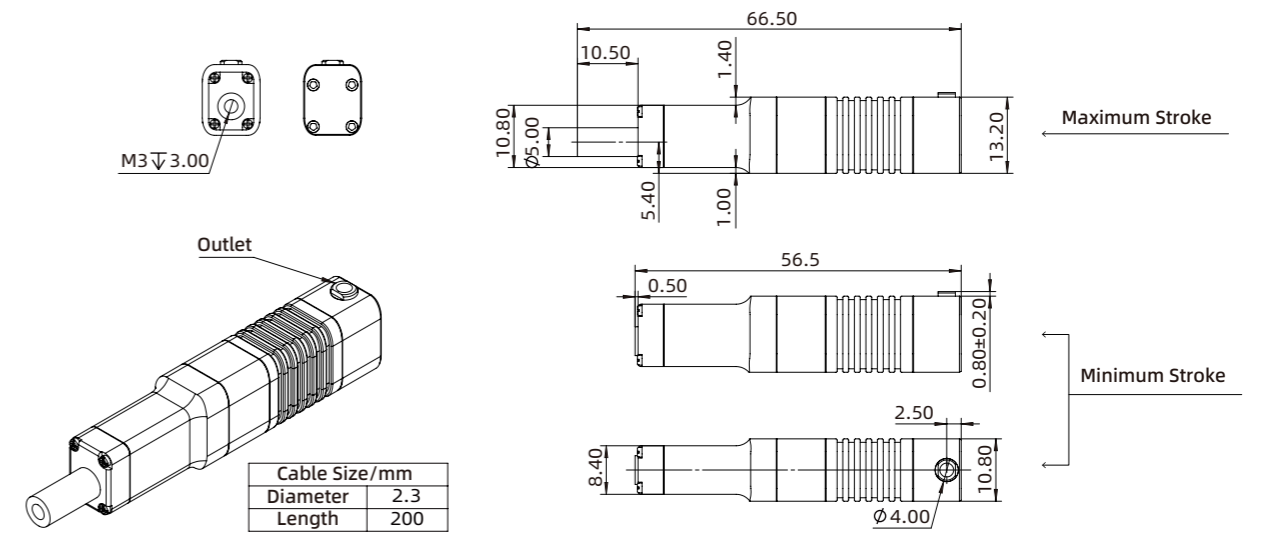

Standard Interface

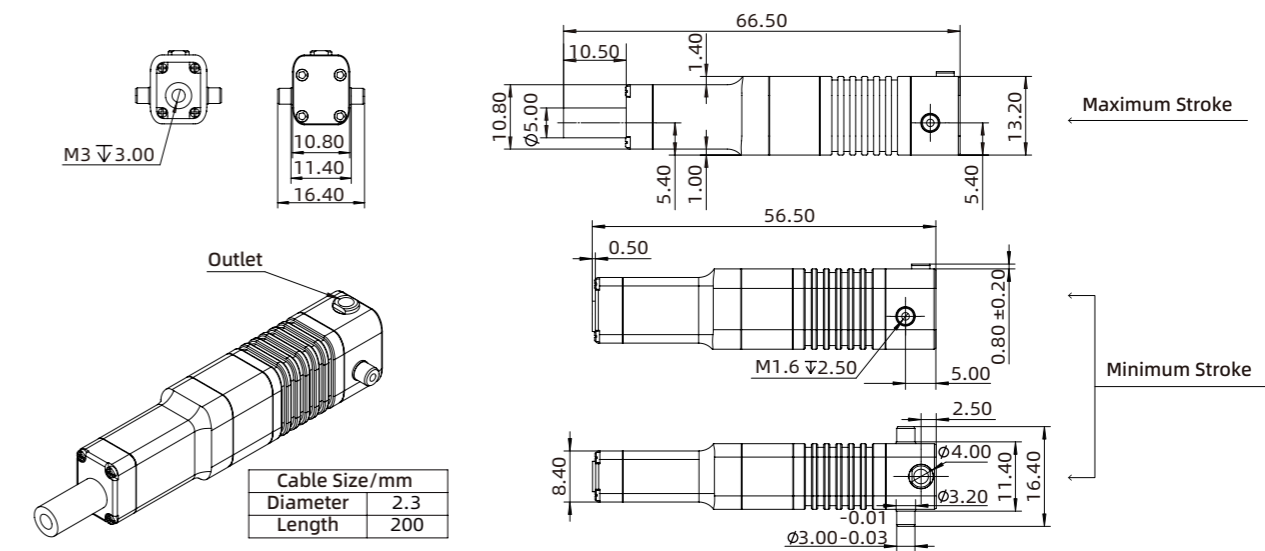

Ear Interface

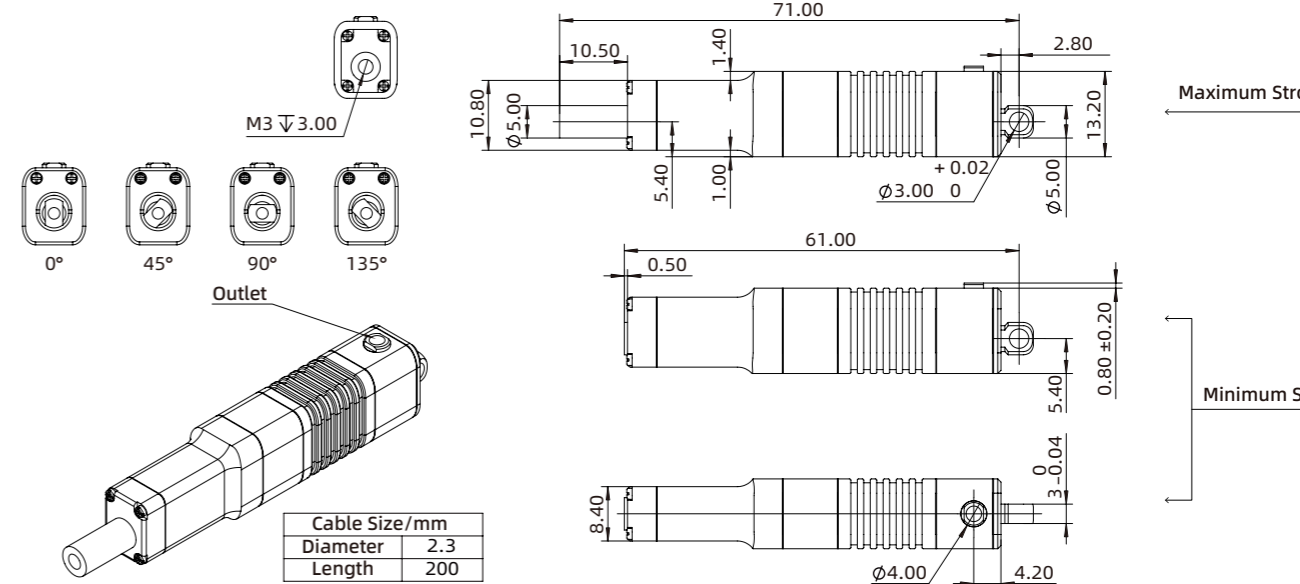

Octagonal Interface

LA16 Series

Micro Linear Servo Actuator

Model Instruction

Series	Speed Level	Mechanical Interface	Electronic Interface	Model code
LA16	02	1	D	LA16-021D
Stroke	02 03 07 09	1-Standard Interface 2-Ear Interface 3-Octagonal Interface	D-LVTTL Serial port P-PWM Serial port	

Standard Parameters

Stroke	Weight	Operating Voltage	Repeatability	Operating Temperature Range	Quiescent Current	Peak Current	IP level
16mm	23g	DC8V±10%	±0.03mm	-10°C~+60°C	0.02A	2A	IP40

Speed Levels and Associated Parameters

Speed Level	Maximum Force	Locked-Rotor Force	Maximum Self-Locking Force	No-load Speed	Full Load Speed	No-Load Current
02	70N	100N	100N	18mm/s	8mm/s	0.2A
03	56N	80N	100N	36mm/s	16mm/s	0.24A
07	42N	60N	50N	50mm/s	21mm/s	0.5A
09	21N	30N	38N	70mm/s	36mm/s	0.5A



Standard Interface



Ear Interface



Octagonal Interface

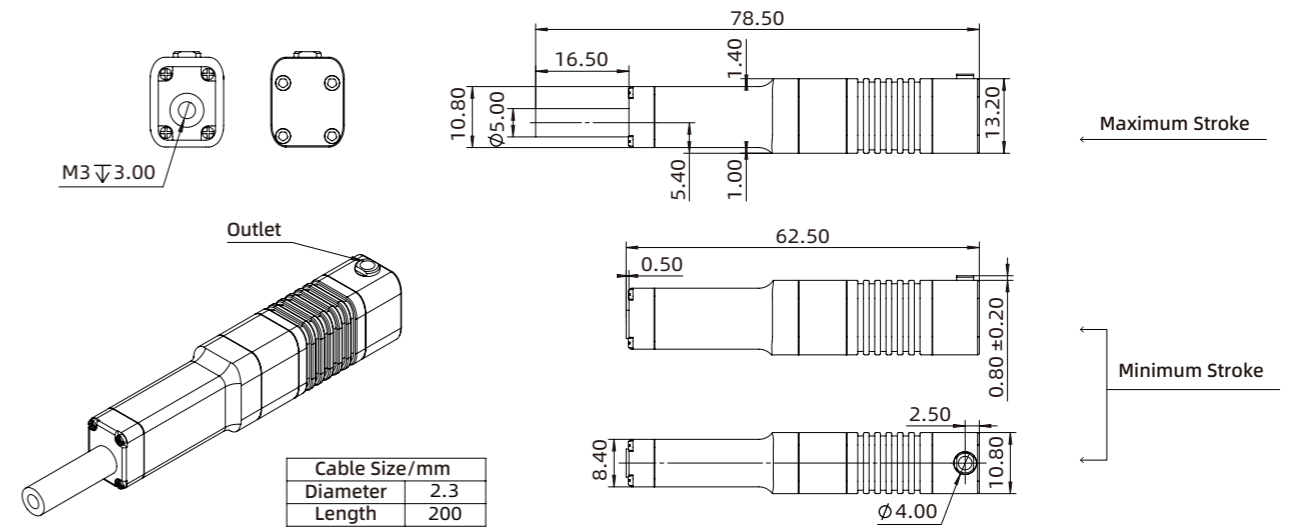

Standard Interface

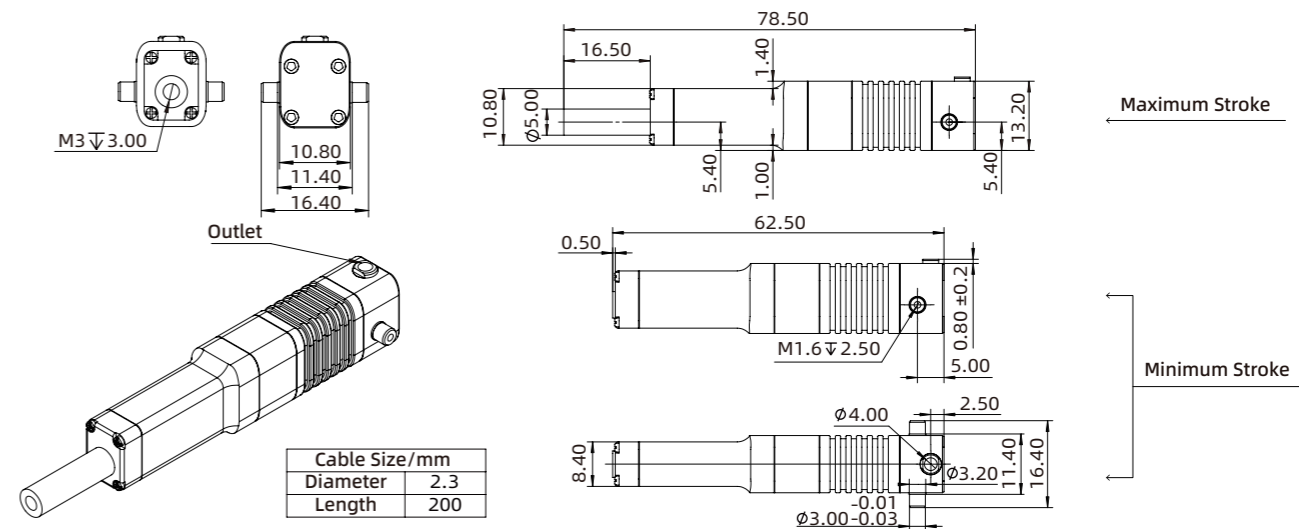

Ear Interface

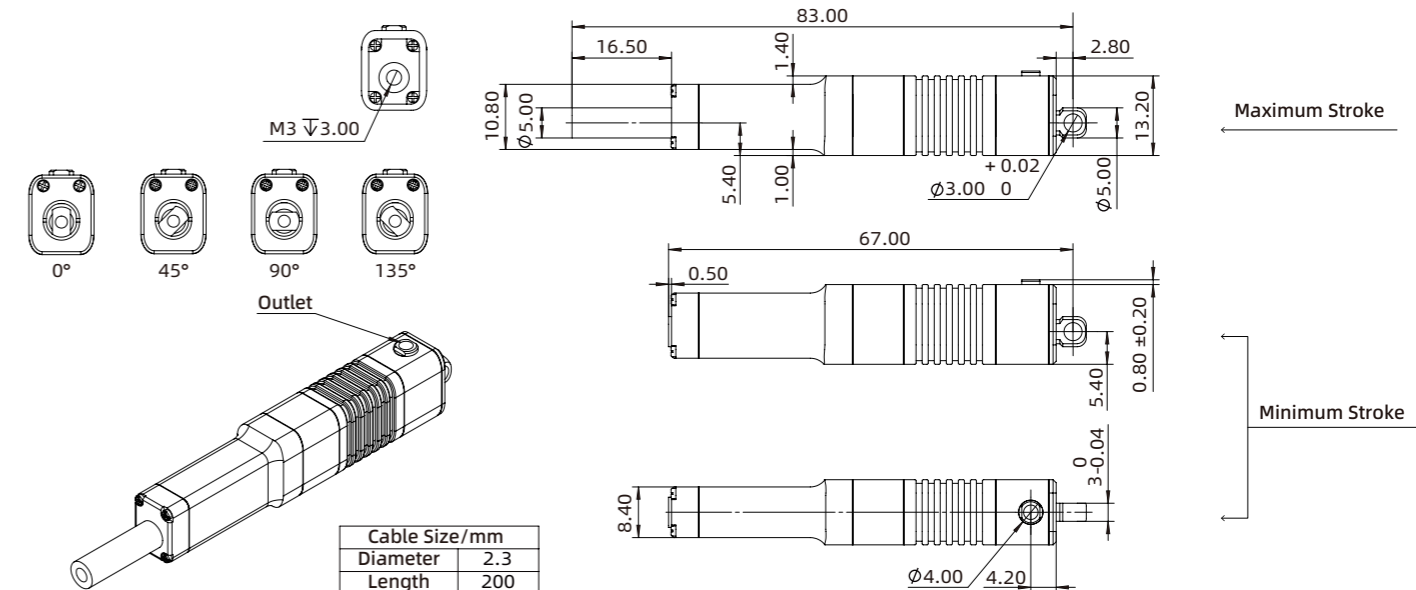

Octagonal Interface

LA30 Series

Micro Linear Servo Actuator

Model Instruction

Series	Speed Level	Mechanical Interface	Electronic Interface	Model code LA30-021D
LA30	02	1	D	
Stroke	02	1-Standard Interface 2-Ear Interface 3-Octagonal Interface	D-LVTTL Serial port P-PWM Serial port	

Standard Parameters

Stroke	Weight	Operating Voltage	Repeatability	Operating Temperature Range	Quiescent Current	Peak Current	IP level
30mm	30g	DC8V±10%	±0.06mm	-10°C~+60°C	0.02A	2A	IP40

Speed Levels and Associated Parameters

Speed Level	Maximum Force	Locked-Rotor Force	Maximum Self-Locking Force	No-load Speed	Full Load Speed	No-Load Current
02	50N	80N	80N	17mm/s	8mm/s	0.3A



Standard Interface



Ear Interface



Octagonal Interface

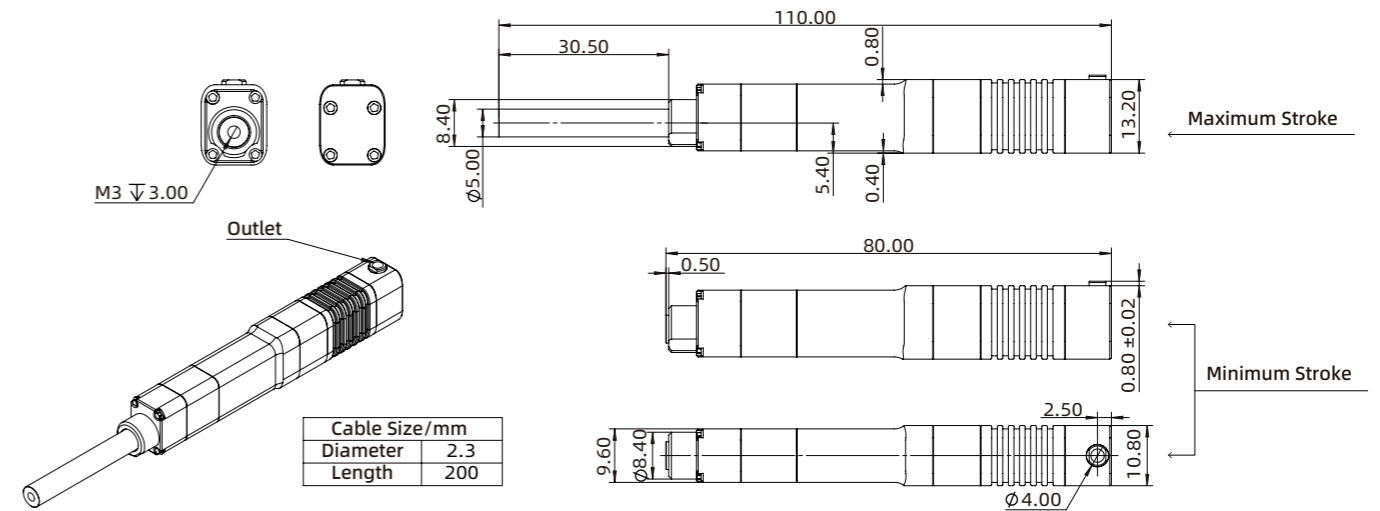

Standard Interface

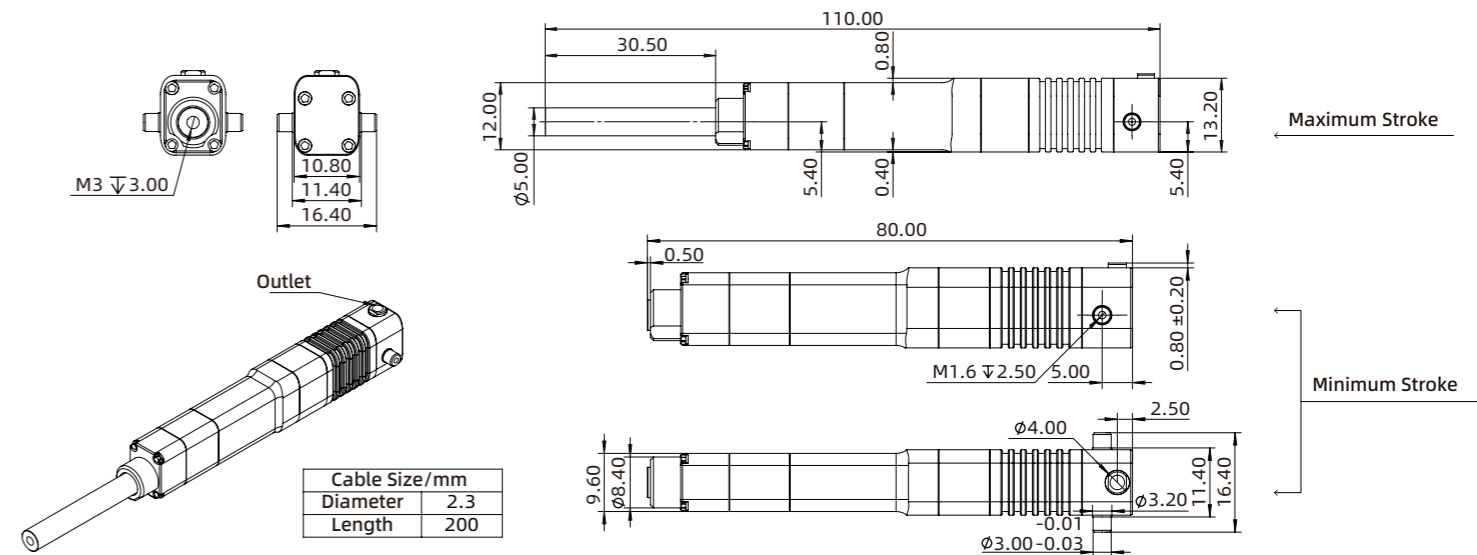

Ear Interface

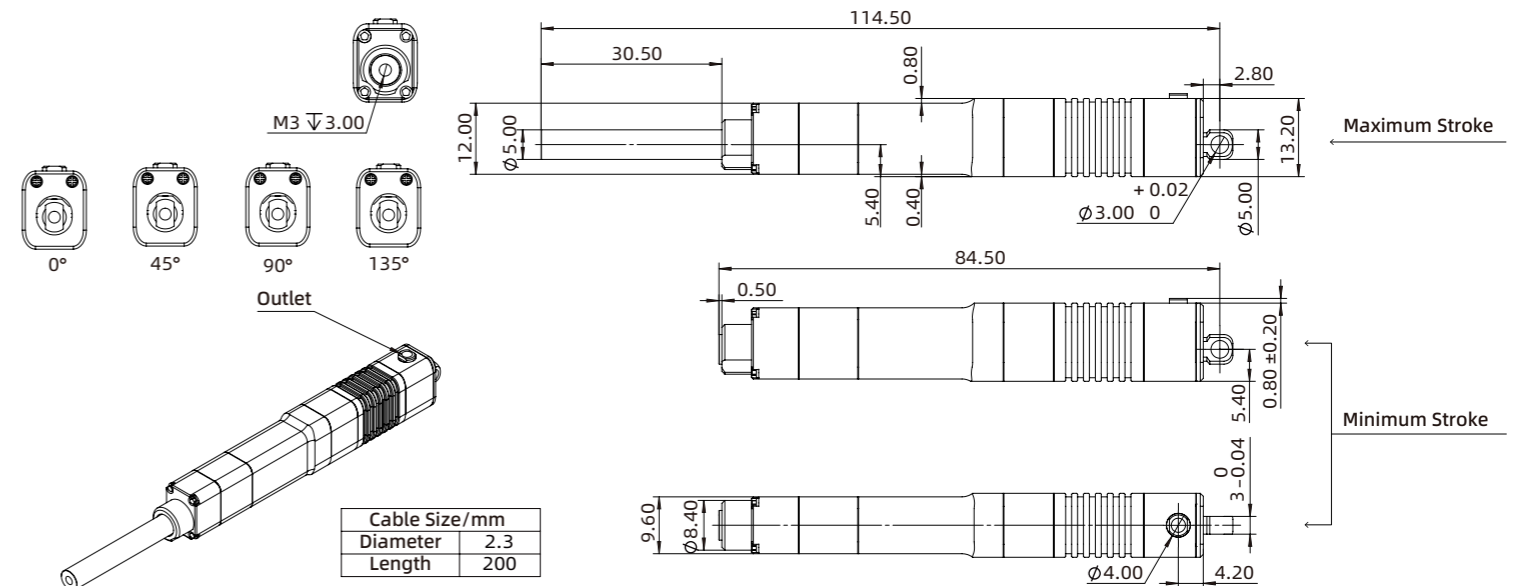

Octagonal Interface

LA50 Series

Micro Linear Servo Actuator

Model Instruction

Series	Speed Level	Mechanical Interface	Electronic Interface	Model code LA50-021D
LA50	02	1	D	
Stroke	02	1-Standard Interface 2-Ear Interface 3-Octagonal Interface	D-LVTTL Serial port P-PWM Serial port	

Standard Parameters

Stroke	Weight	Operating Voltage	Repeatability	Operating Temperature Range	Quiescent Current	Peak Current	IP level
50mm	42g	DC8V±10%	±0.1mm	-10°C~+60°C	0.02A	2A	IP40

Speed Levels and Associated Parameters

Speed Level	Maximum Force	Locked-Rotor Force	Maximum Self-Locking Force	No-load Speed	Full Load Speed	No-Load Current
02	50N	80N	80N	17mm/s	8mm/s	0.3A



Standard Interface



Ear Interface



Octagonal Interface

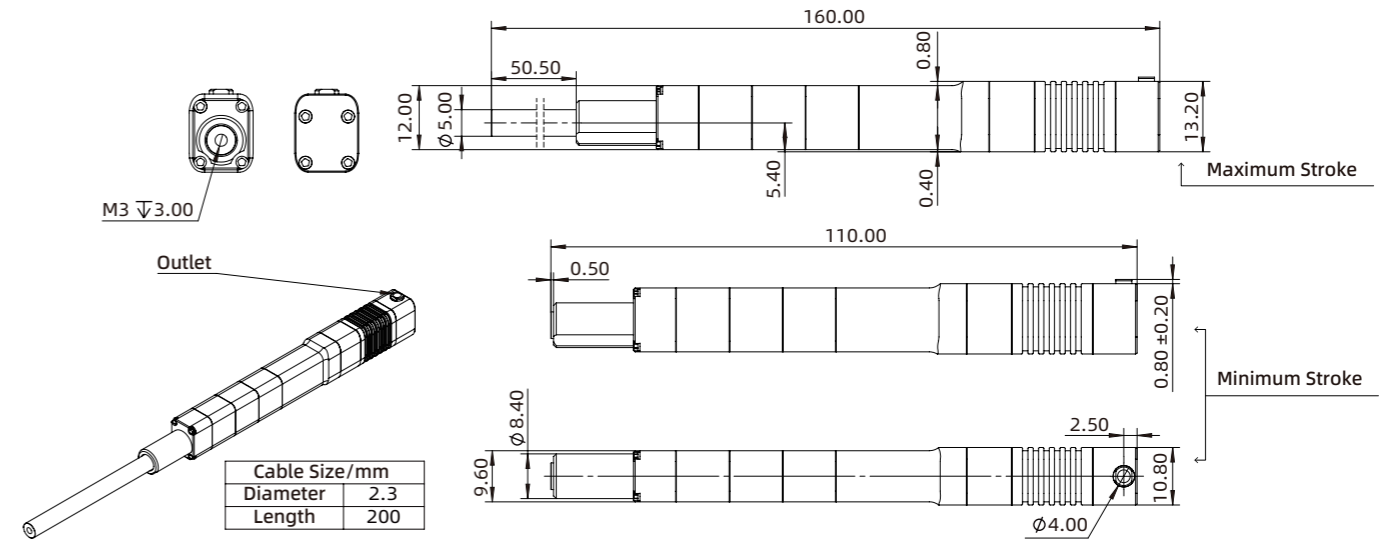

Standard Interface

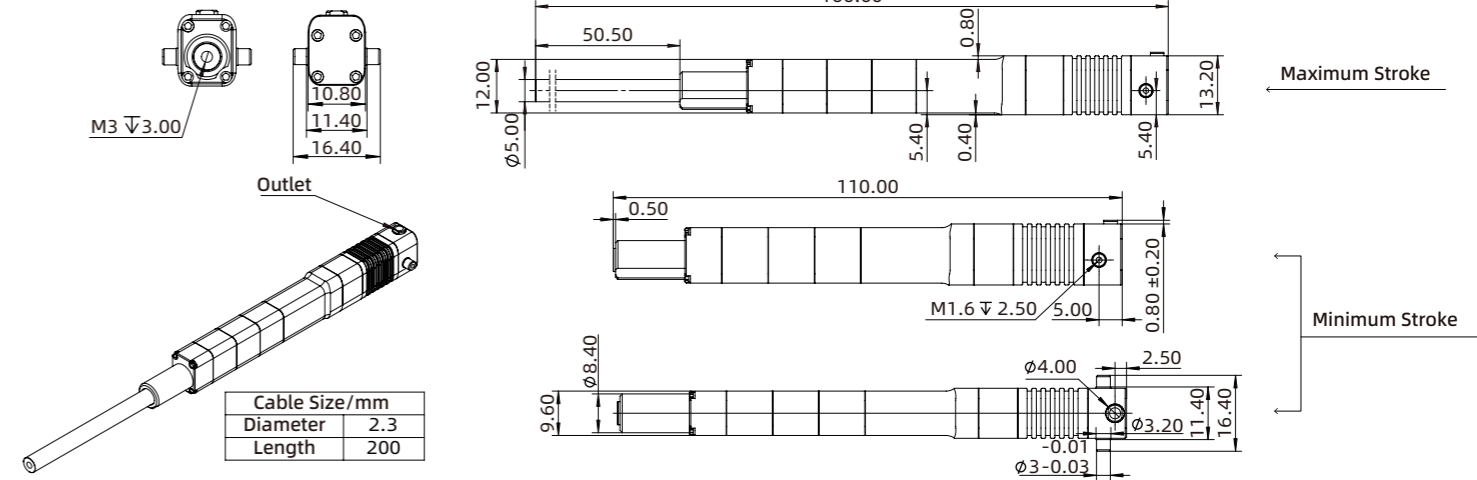

Ear Interface

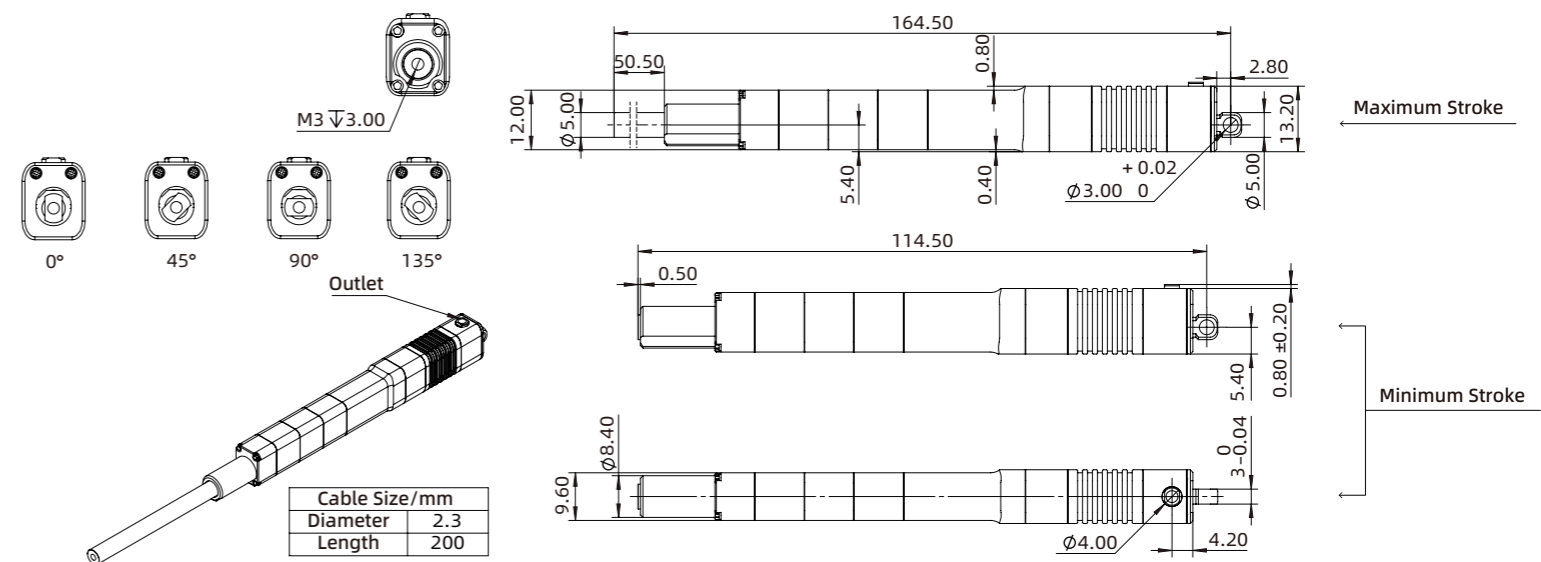

Octagonal Interface

LAS10 Series

Micro Linear Servo Actuator

Model Instruction

Series	Speed Level	Mechanical Interface	Electronic Interface	Model code
LAS10	02	1	D	LAS10-021D
Stroke	02 03 06 08 10	1-Standard Interface 3-Octagonal Interface	D-LVTTL Serial port P-PWM Serial port	

Standard Parameters

Stroke	Weight	Operating Voltage	Repeatability	Operating Temperature Range	Quiescent Current	Peak Current	IP level
10mm	24g	DC8V±10%	±0.02mm	-10°C~+60°C	0.02A	2A	IP40

Speed Levels and Associated Parameters

Speed Level	Maximum Force	Locked-Rotor Force	Maximum Self-Locking Force	No-load Speed	Full Load Speed	No-Load Current
02	105N	150N	150N	13mm/s	4mm/s	0.2A
03	56N	80N	150N	26mm/s	12mm/s	0.24A
06	49N	70N	50N	38mm/s	18mm/s	0.5A
08	35N	50N	38N	53mm/s	27mm/s	0.5A
10	31.5N	45N	30N	62mm/s	39mm/s	0.5A



Standard Interface



Octagonal Interface

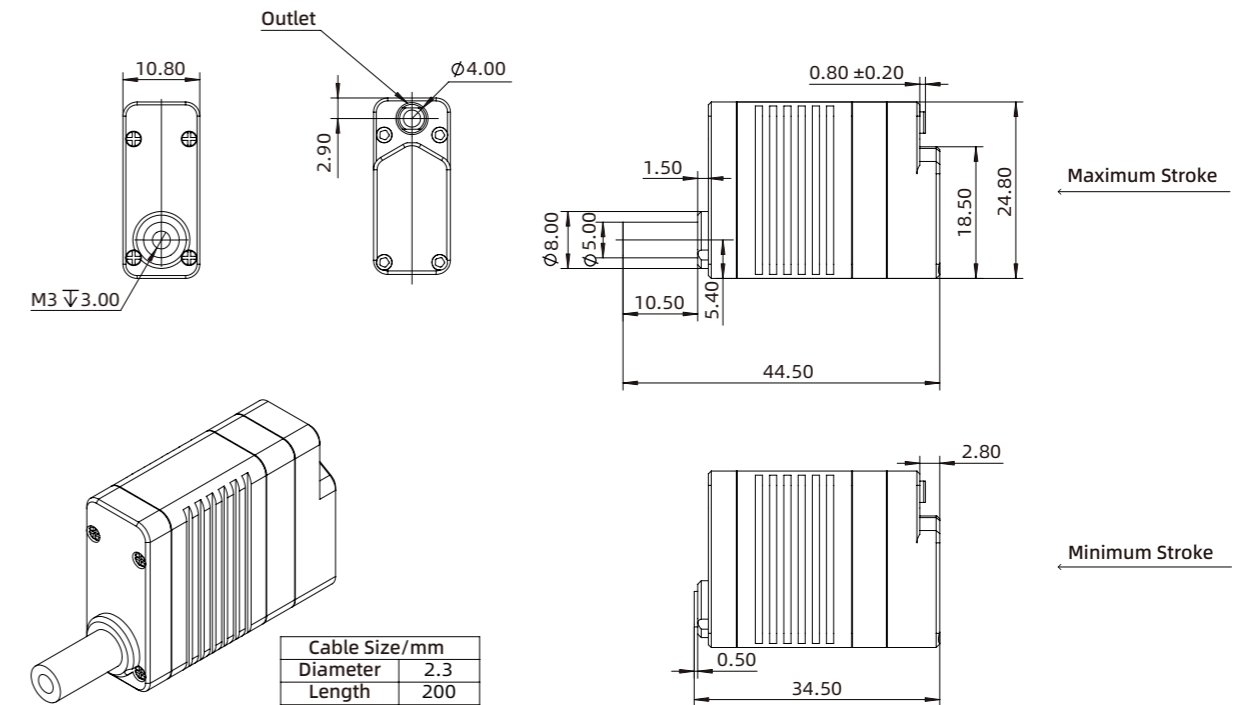

Standard Interface

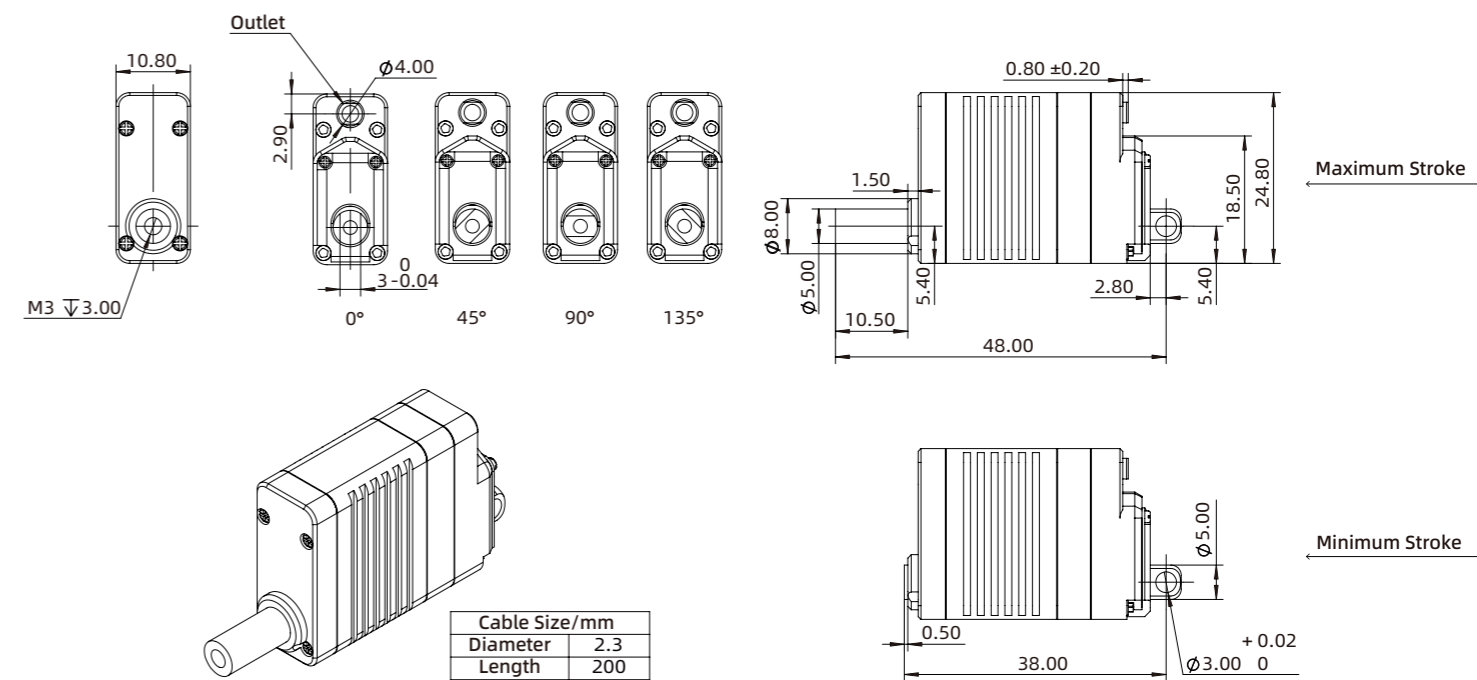

Octagonal Interface

LAS16 Series

Micro Linear Servo Actuator

Model Instruction

Series	Speed Level	Mechanical Interface	Electronic Interface	Model code
LAS16	02	1	D	LAS16-021D
Stroke	02 03 06 08 10	1-Standard Interface 3-Octagonal Interface	D-LVTTL Serial port P-PWM Serial port	

Standard Parameters

Stroke	Weight	Operating Voltage	Repeatability	Operating Temperature Range	Quiescent Current	Peak Current	IP level
16mm	27g	DC8V±10%	±0.03mm	-10°C~+60°C	0.02A	2A	IP40

Speed Levels and Associated Parameters

Speed Level	Maximum Force	Locked-Rotor Force	Maximum Self-Locking Force	No-load Speed	Full Load Speed	No-Load Current
02	105N	150N	150N	13mm/s	4mm/s	0.2A
03	56N	80N	150N	26mm/s	12mm/s	0.24A
06	49N	70N	50N	38mm/s	18mm/s	0.5A
08	35N	50N	38N	53mm/s	27mm/s	0.5A
10	31.5N	45N	30N	62mm/s	39mm/s	0.5A



Standard Interface



Octagonal Interface

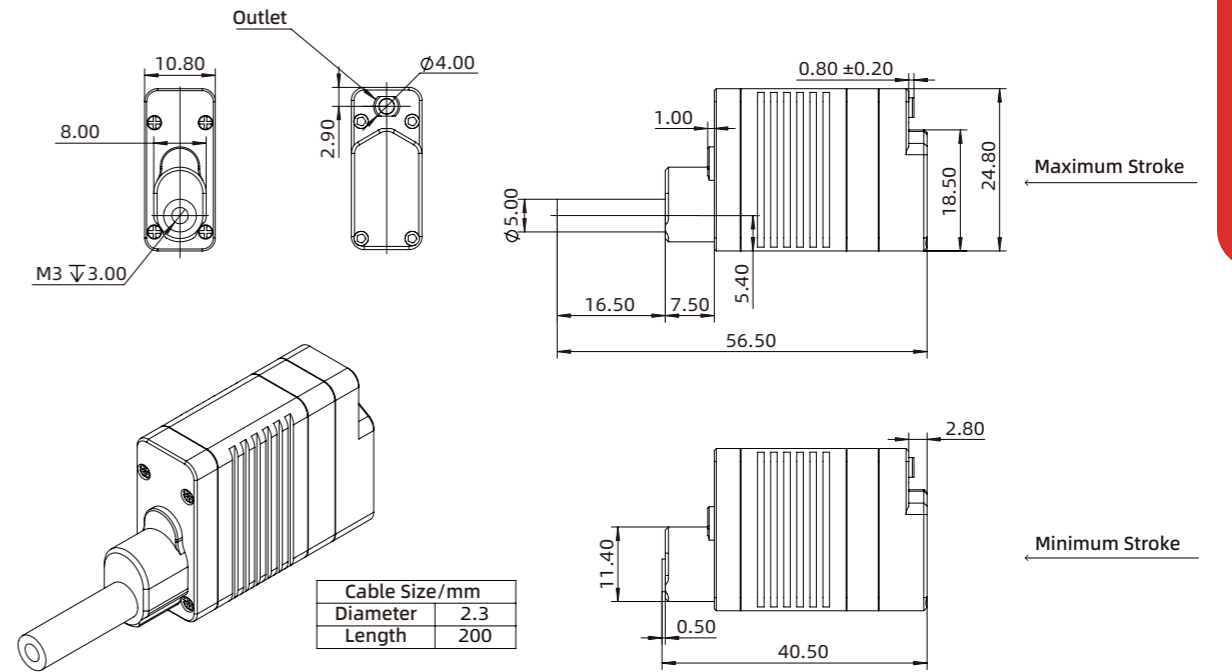

Standard Interface

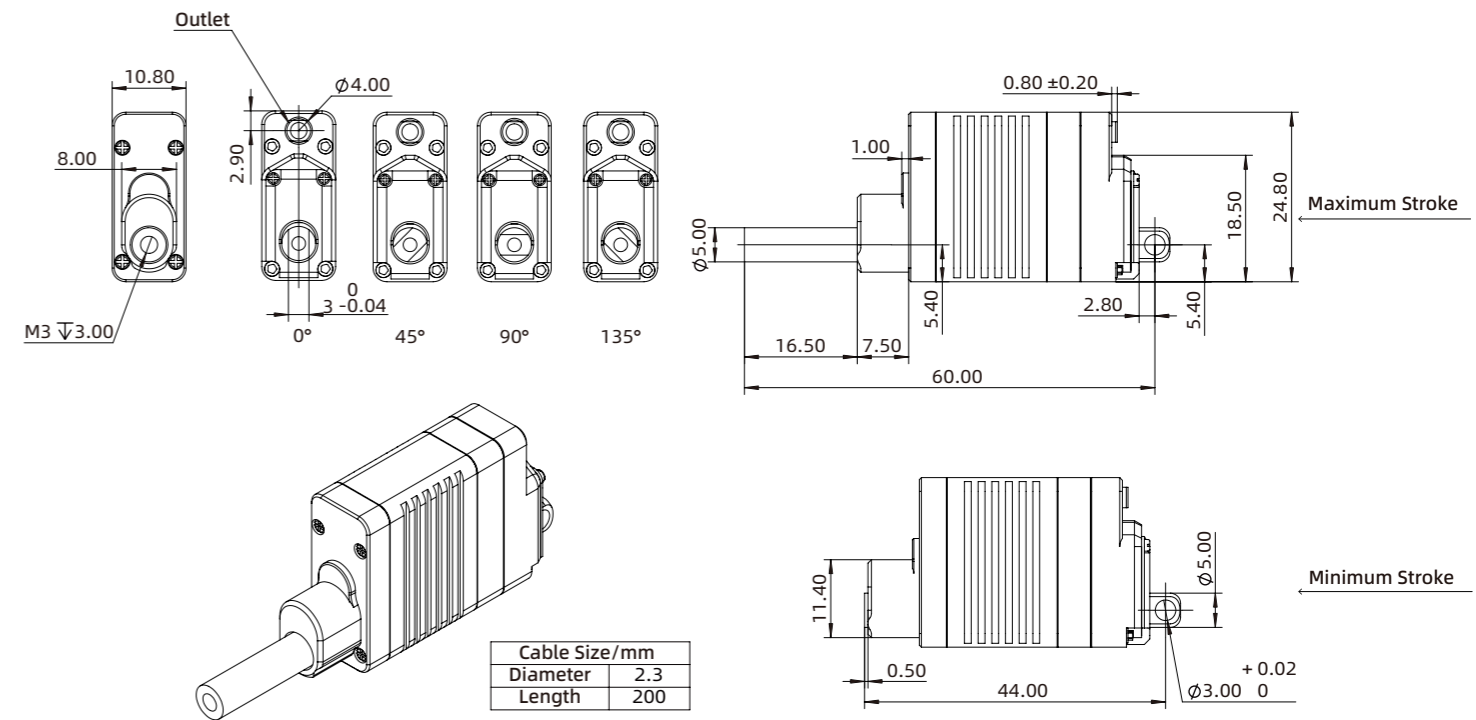

Octagonal Interface

LAS30 Series

Micro Linear Servo Actuator

Model Instruction

Series	Speed Level	Mechanical Interface	Electronic Interface	Model code
LAS30	02	1	D	LAS30-021D
Stroke	02	1-Standard Interface 3-Octagonal Interface	D-LVTTL Serial port P-PWM Serial port	

Standard Parameters

Stroke	Weight	Operating Voltage	Repeatability	Operating Temperature Range	Quiescent Current	Peak Current	IP level
30mm	35g	DC8V±10%	±0.06mm	-10°C~+60°C	0.02A	2A	IP40

Speed Levels and Associated Parameters

Speed Level	Maximum Force	Locked-Rotor Force	Maximum Self-Locking Force	No-load Speed	Full Load Speed	No-Load Current
02	80N	110N	110N	13mm/s	6mm/s	0.3A



Standard Interface



Octagonal Interface

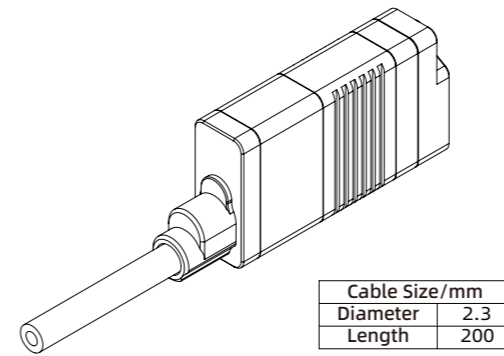
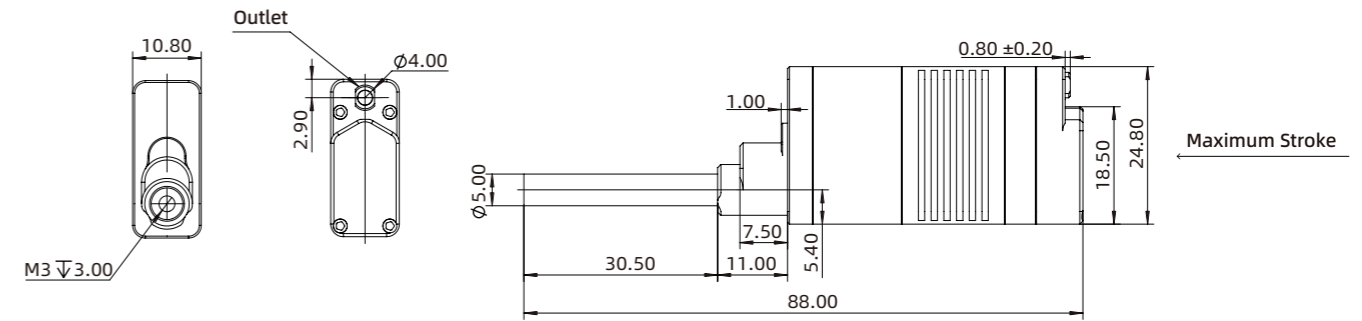

Cable Size/mm	
Diameter	2.3
Length	200

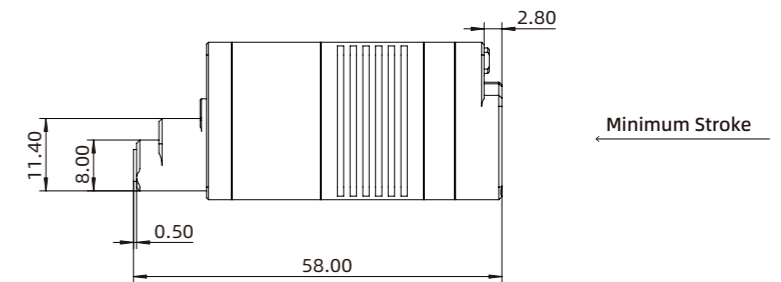

Standard Interface

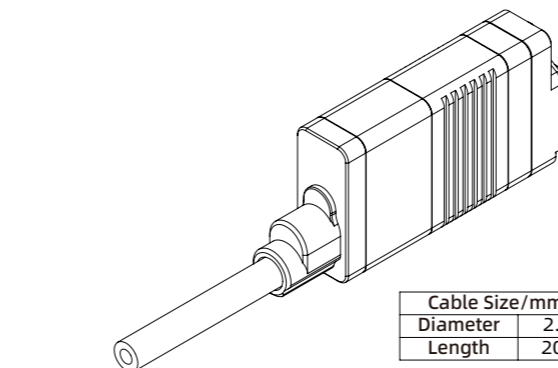
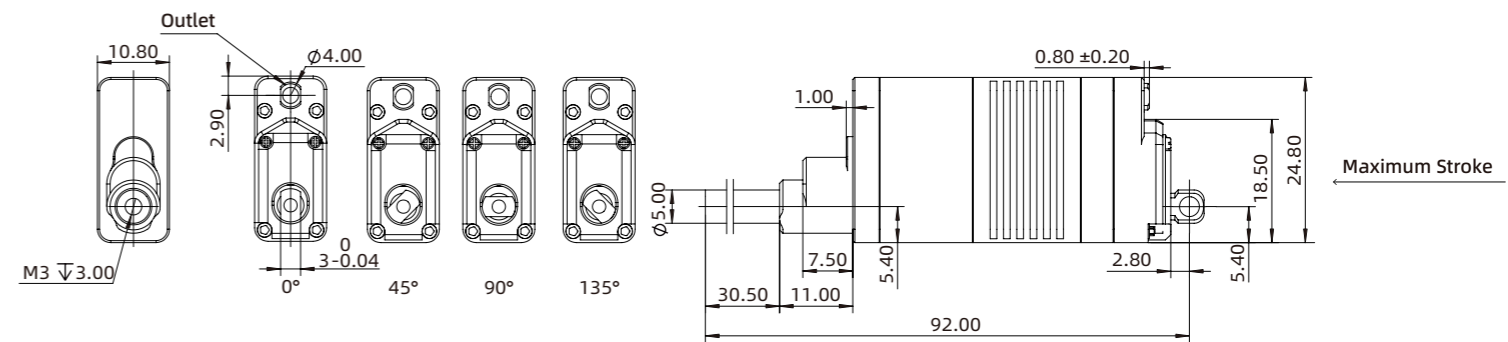

Cable Size/mm	
Diameter	2.3
Length	200

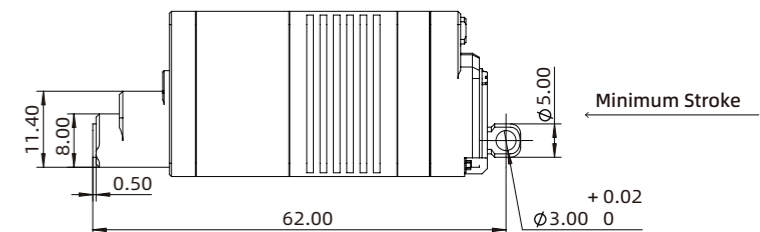

Octagonal Interface

LAS Series

LAF10 Series

Micro Linear Servo Actuator

Model Instruction

Series	Speed Level	Mechanical Interface	Electronic Interface	Model code
LAF10	02	4	D	LAF10-024D
Stroke	02 03 07 09	4-Spherical Plain Bearing	D-LVTTL Serial port	

Standard Parameters

Stroke	Weight	Operating Voltage	Repeatability	Operating Temperature Range	Quiescent Current	Peak Current	Force Sensor Detection Range	Force Sensor Resolution	IP Level
10mm	29g	DC8V±10%	±0.02mm	-10°C~+60°C	0.05A	2A	-100N~+100N	1N	IP40

Speed Levels and Associated Parameters

Speed Level	Maximum Force	Locked-Rotor Force	Maximum Self-Locking Force	No-load Speed	Full Load Speed	No-Load Current
02	70N	100N	100N	18mm/s	8mm/s	0.23A
03	56N	80N	100N	36mm/s	16mm/s	0.27A
07	42N	60N	50N	50mm/s	21mm/s	0.53A
09	21N	30N	38N	70mm/s	36mm/s	0.53A

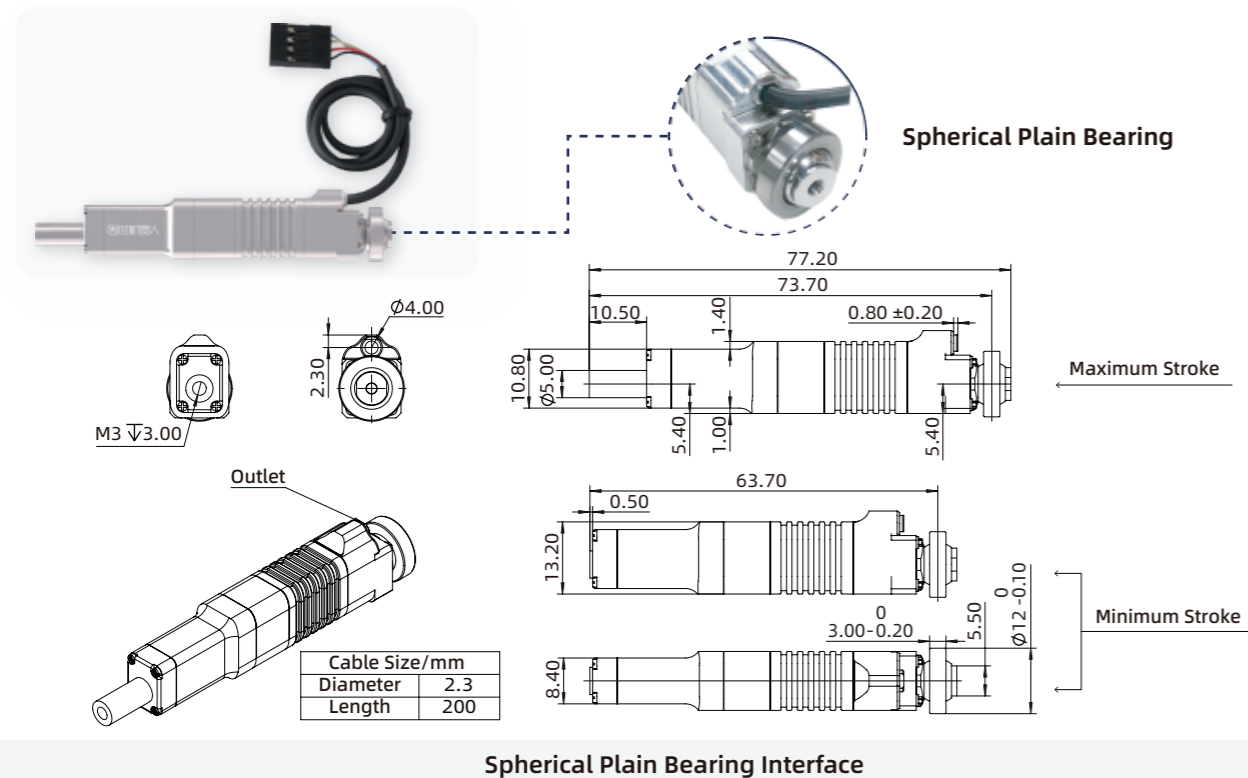

LAF16 Series

Micro Linear Servo Actuator

Model Instruction

Series	Speed Level	Mechanical Interface	Electronic Interface	Model code
LAF16	02	4	D	LAF16-024D
Stroke	02 03 07 09	4-Spherical Plain Bearing	D-LVTTL Serial port	

Standard Parameters

Stroke	Weight	Operating Voltage	Repeatability	Operating Temperature Range	Quiescent Current	Peak Current	Force Sensor Detection Range	Force Sensor Resolution	IP Level
16mm	33g	DC8V±10%	±0.03mm	-10°C~+60°C	0.05A	2A	-100N~+100N	1N	IP40

Speed Levels and Associated Parameters

Speed Level	Maximum Force	Locked-Rotor Force	Maximum Self-Locking Force	No-load Speed	Full Load Speed	No-Load Current
02	70N	100N	100N	18mm/s	8mm/s	0.23A
03	56N	80N	100N	36mm/s	16mm/s	0.27A
07	42N	60N	50N	50mm/s	21mm/s	0.53A
09	21N	30N	38N	70mm/s	36mm/s	0.53A

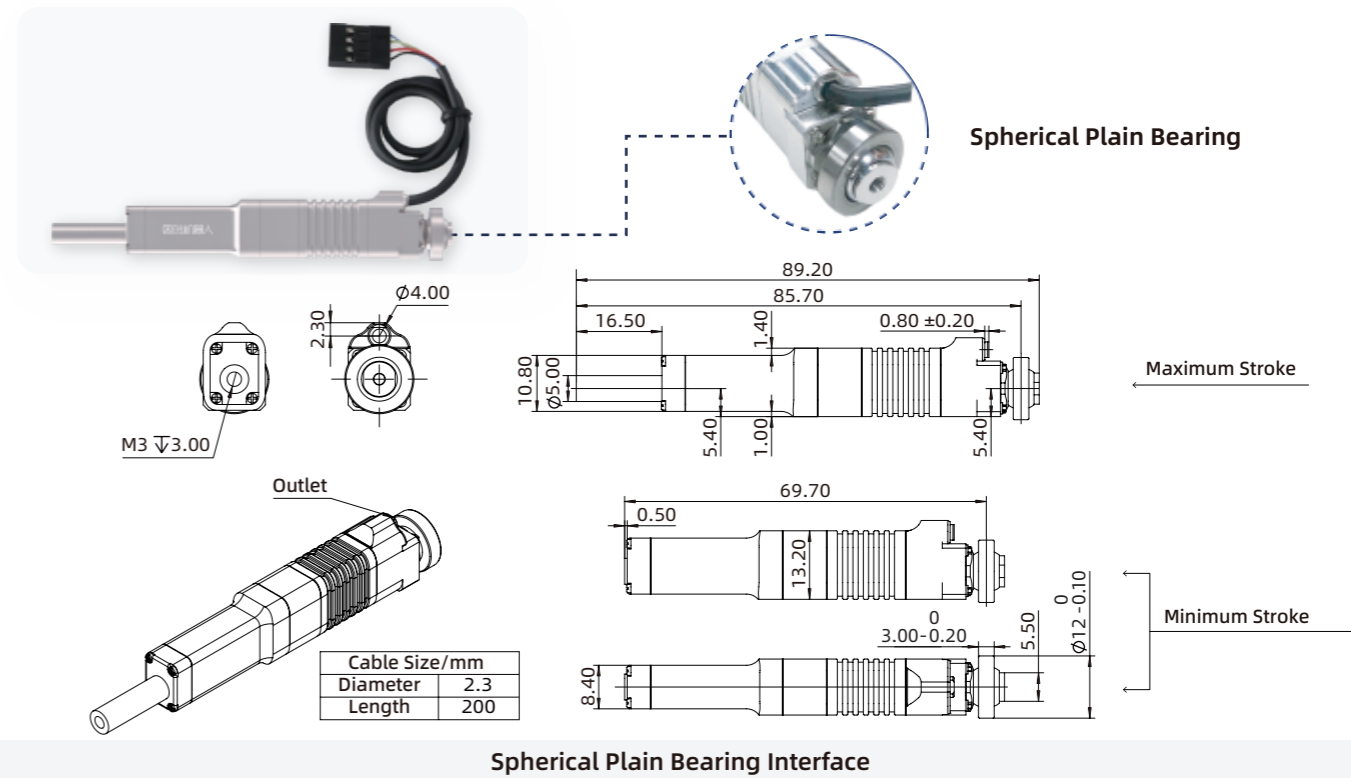

LAF30 Series

Micro Linear Servo Actuator

Model Instruction

Series	Speed Level	Mechanical Interface	Electronic Interface	Model code
LAF30	02	4	D	LAF30-024D
Stroke	02	4-Spherical Plain Bearing	D-LVTTL Serial port	

Standard Parameters

Stroke	Weight	Operating Voltage	Repeatability	Operating Temperature Range	Quiescent Current	Peak Current	Force Sensor Detection Range	Force Sensor Resolution	IP level
30mm	38g	DC8V±10%	±0.06mm	-10°C~+60°C	0.05A	2A	-100N~+100N	1N	IP40

Speed Levels and Associated Parameters

Speed Level	Maximum Force	Locked-Rotor Force	Maximum Self-Locking Force	No-load Speed	Full Load Speed	No-Load Current
02	50N	80N	80N	17mm/s	8mm/s	0.3A

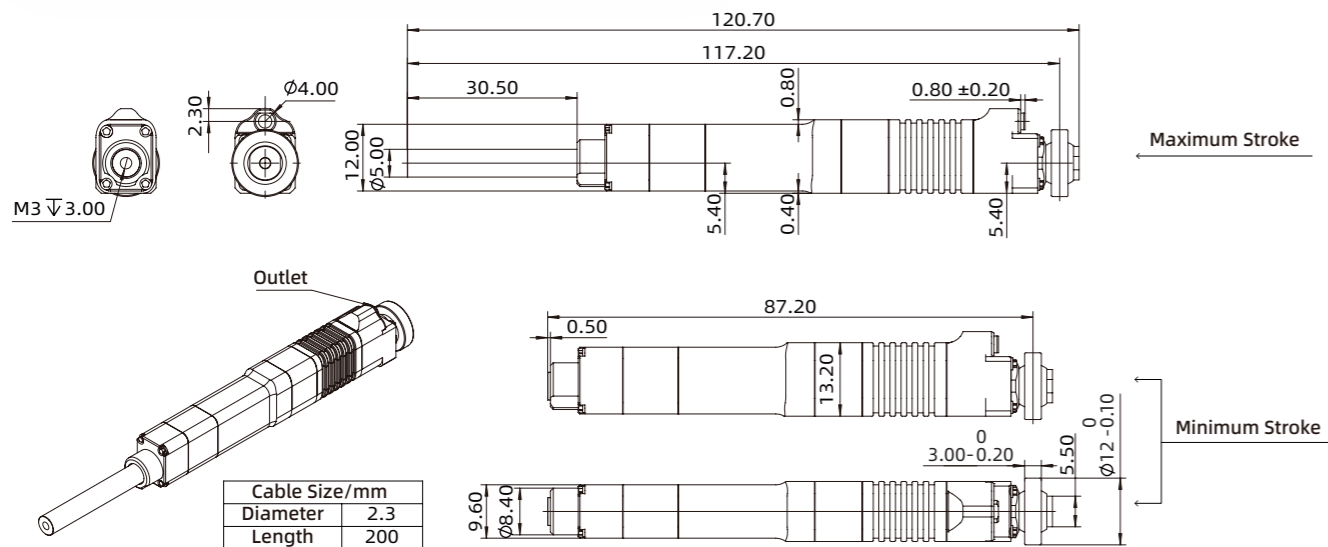
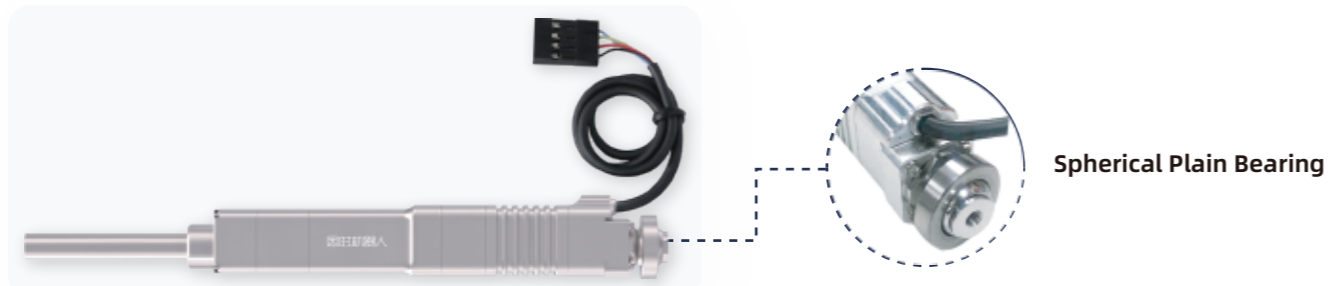

Spherical Plain Bearing Interface

LAF50 Series

Micro Linear Servo Actuator

Model Instruction

Series	Speed Level	Mechanical Interface	Electronic Interface	Model code
LAF50	02	4	D	LAF50-024D
Stroke	02	4-Spherical Plain Bearing	D-LVTTL Serial port	

Standard Parameters

Stroke	Weight	Operating Voltage	Repeatability	Operating Temperature Range	Quiescent Current	Peak Current	Force Sensor Detection Range	Force Sensor Resolution	IP level
50mm	50g	DC8V±10%	±0.1mm	-10°C~+60°C	0.05A	2A	-100N~+100N	1N	IP40

Speed Levels and Associated Parameters

Speed Level	Maximum Force	Locked-Rotor Force	Maximum Self-Locking Force	No-load Speed	Full Load Speed	No-Load Current
02	50N	80N	80N	17mm/s	8mm/s	0.3A

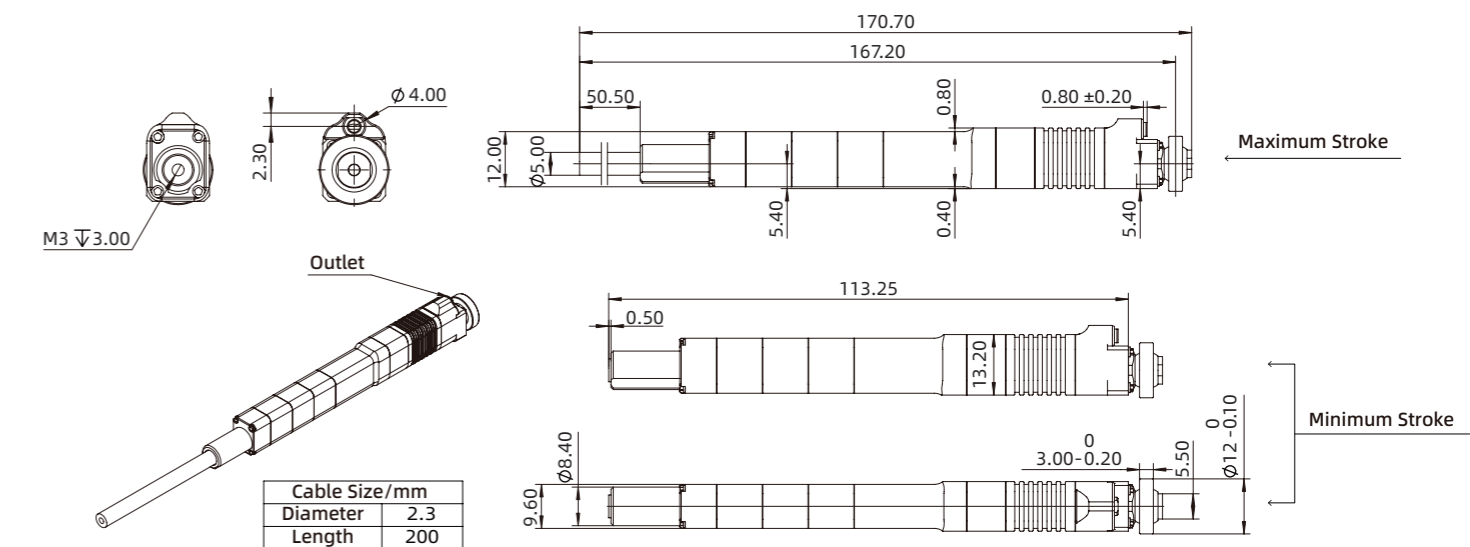
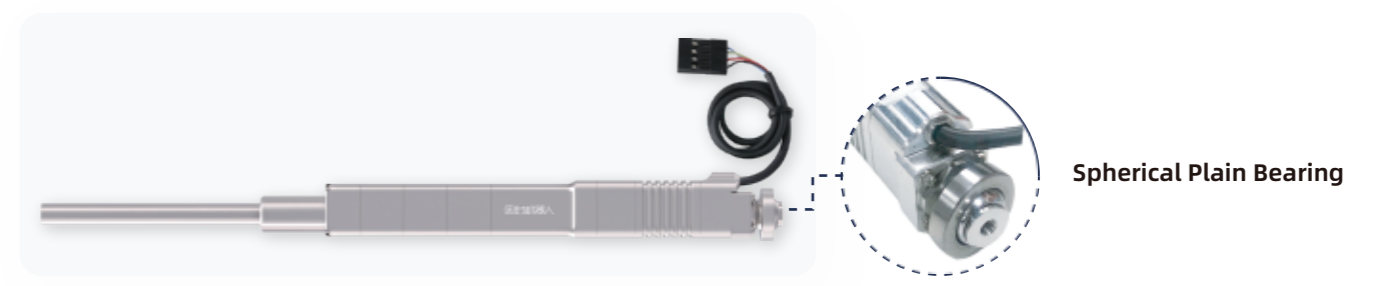

Spherical Plain Bearing Interface

LASF10 Series

Micro Linear Servo Actuator

Model Instruction

Series	Speed Level	Mechanical Interface	Electronic Interface	Model code
LASF10	02	4	D	LASF10-024D
Stroke	02 03 06 08 10	4-Spherical Plain Bearing	D-LVTTL Serial port	

Standard Parameters

Stroke	Weight	Operating Voltage	Repeatability	Operating Temperature Range	Quiescent Current	Peak Current	Force Sensor Detection Range	Force Sensor Resolution	IP level
10mm	32g	DC8V±10%	±0.02mm	-10°C~+60°C	0.05A	2A	-100N~+100N	1N	IP40

Speed Levels and Associated Parameters

Speed Level	Maximum Force	Locked-Rotor Force	Maximum Self-Locking Force	No-load Speed	Full Load Speed	No-Load Current
02	105N	150N	150N	13mm/s	4mm/s	0.53A
03	56N	80N	150N	26mm/s	12mm/s	0.63A
06	49N	70N	50N	38mm/s	18mm/s	0.73A
08	35N	50N	38N	53mm/s	27mm/s	0.73A
10	31.5N	45N	30N	62mm/s	39mm/s	0.73A

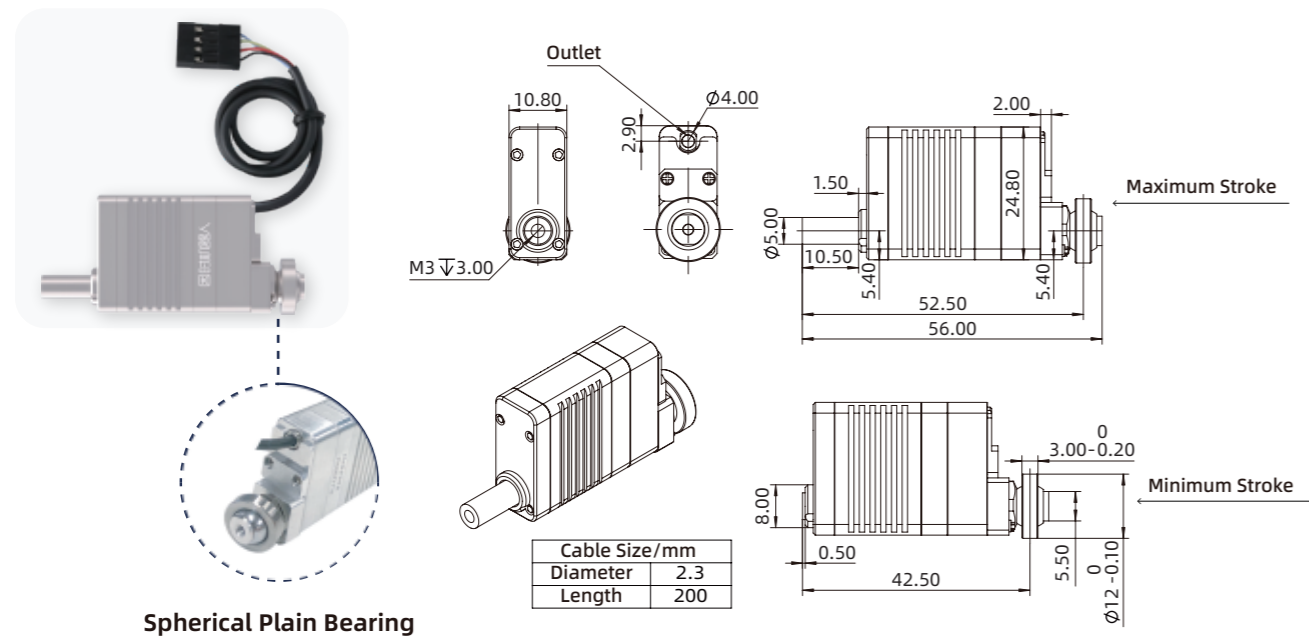

Spherical Plain Bearing Interface

LAFS16 Series

Micro Linear Servo Actuator

Model Instruction

Series	Speed Level	Mechanical Interface	Electronic Interface	Model code
LASF16	02	4	D	LASF16-024D
Stroke	02 03 06 08 10	4-Spherical Plain Bearing	D-LVTTL Serial port	

Standard Parameters

Stroke	Weight	Operating Voltage	Repeatability	Operating Temperature Range	Quiescent Current	Peak Current	Force Sensor Detection Range	Force Sensor Resolution	IP level
16mm	36g	DC8V±10%	±0.03mm	-10°C~+60°C	0.05A	2A	-100N~+100N	1N	IP40

Speed Levels and Associated Parameters

Speed Level	Maximum Force	Locked-Rotor Force	Maximum Self-Locking Force	No-load Speed	Full Load Speed	No-Load Current
02	105N	150N	150N	13mm/s	4mm/s	0.53A
03	56N	80N	150N	26mm/s	12mm/s	0.63A
06	49N	70N	50N	38mm/s	18mm/s	0.73A
08	35N	50N	38N	53mm/s	27mm/s	0.73A
10	31.5N	45N	30N	62mm/s	39mm/s	0.73A

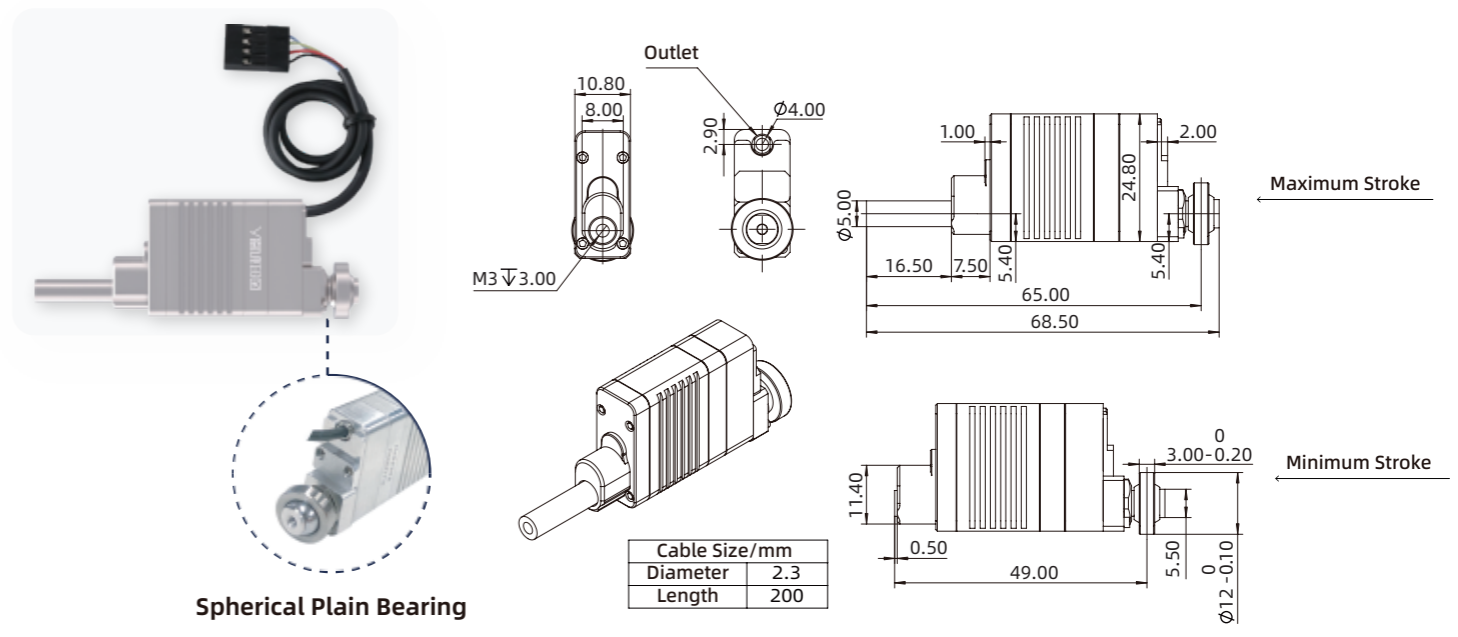

Spherical Plain Bearing Interface

LASF30 Series

Micro Linear Servo Actuator

Model Instruction

Series	Speed Level	Mechanical Interface	Electronic Interface	Model code
LASF30	02	4	D	LASF30-024D
Stroke	02	4-Spherical Plain Bearing	D-LVTTL Serial port	

Standard Parameters

Stroke	Weight	Operating Voltage	Repeatability	Operating Temperature Range	Quiescent Current	Peak Current	Force Sensor Detection Range	Force Sensor Resolution	IP level
30mm	44g	DC8V±10%	±0.06mm	-10°C~+60°C	0.05A	2A	-100N~+100N	1N	IP40

Speed Levels and Associated Parameters

Speed Level	Maximum Force	Locked-Rotor Force	Maximum Self-Locking Force	No-load Speed	Full Load Speed	No-Load Current
02	80N	110N	110N	13mm/s	6mm/s	0.3A

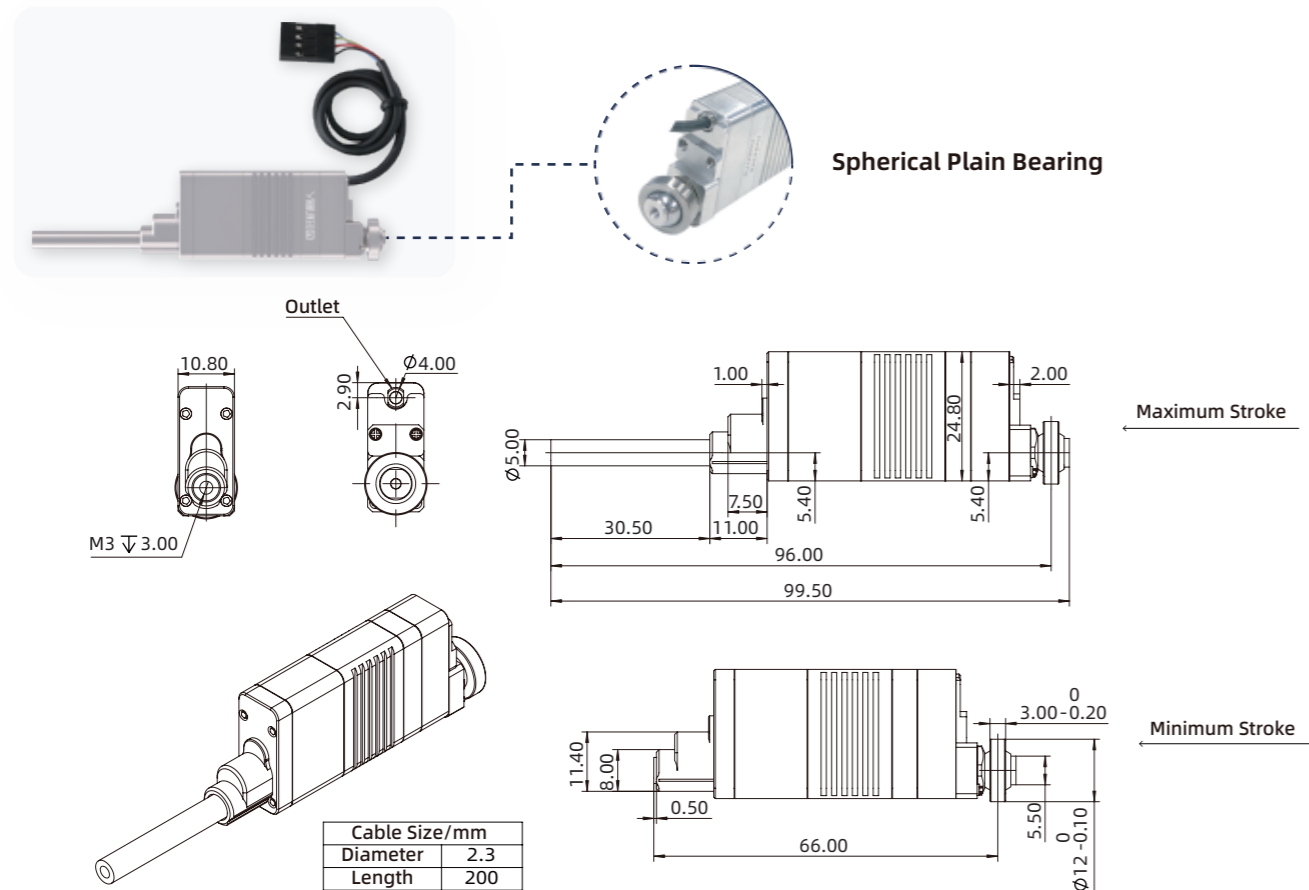

Spherical Plain Bearing Interface

BLAC05-C162

Micro Linear Servo Actuator

Standard Parameters

Stroke	Weight	Operating Voltage	Repeatability	Operating Temperature Range	Quiescent Current	Peak Current	IP level
5mm	170g	DC12V±10%	± 0.002mm	-10°C~+60°C	55mA	1.4A	IP40

Associated Parameters

Maximum Force	Locked-Rotor Force	Maximum Self-Locking Force	No-load Speed	Full Load Speed	No-Load Current	Communication interface	Motor
250N	300N	150N	2.4mm/s	2mm/s	200mA	RS485	Coreless Brushless DC Motors

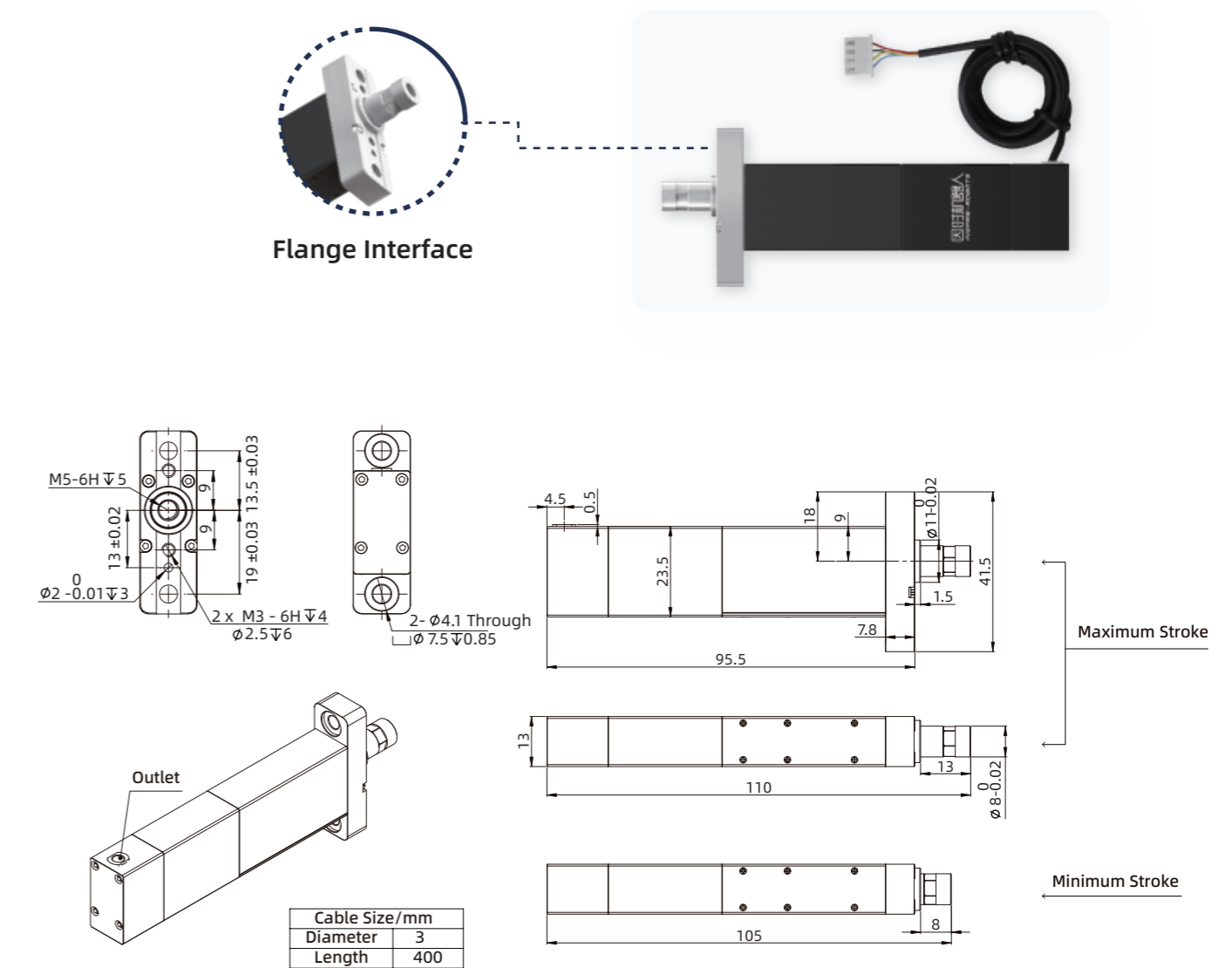

Flange Interface

BLAS10-C152

Micro Linear Servo Actuator

Standard Parameters

Stroke	Weight	Operating Voltage	Repeatability	Operating Temperature Range	Quiescent Current	Peak Current	IP Level
10mm	87g	DC12V±10%	±0.01mm	-10°C~+60°C	50mA	2A	IP40

Associated Parameters

Maximum Force	Locked-Rotor Force	Maximum Self-Locking Force	No-load Speed	Full Load Speed	No-Load Current	Communication interface	Motor
150N	200N	70N	8mm/s	5mm/s	400mA	RS485	Coreless Brushless DC Motors

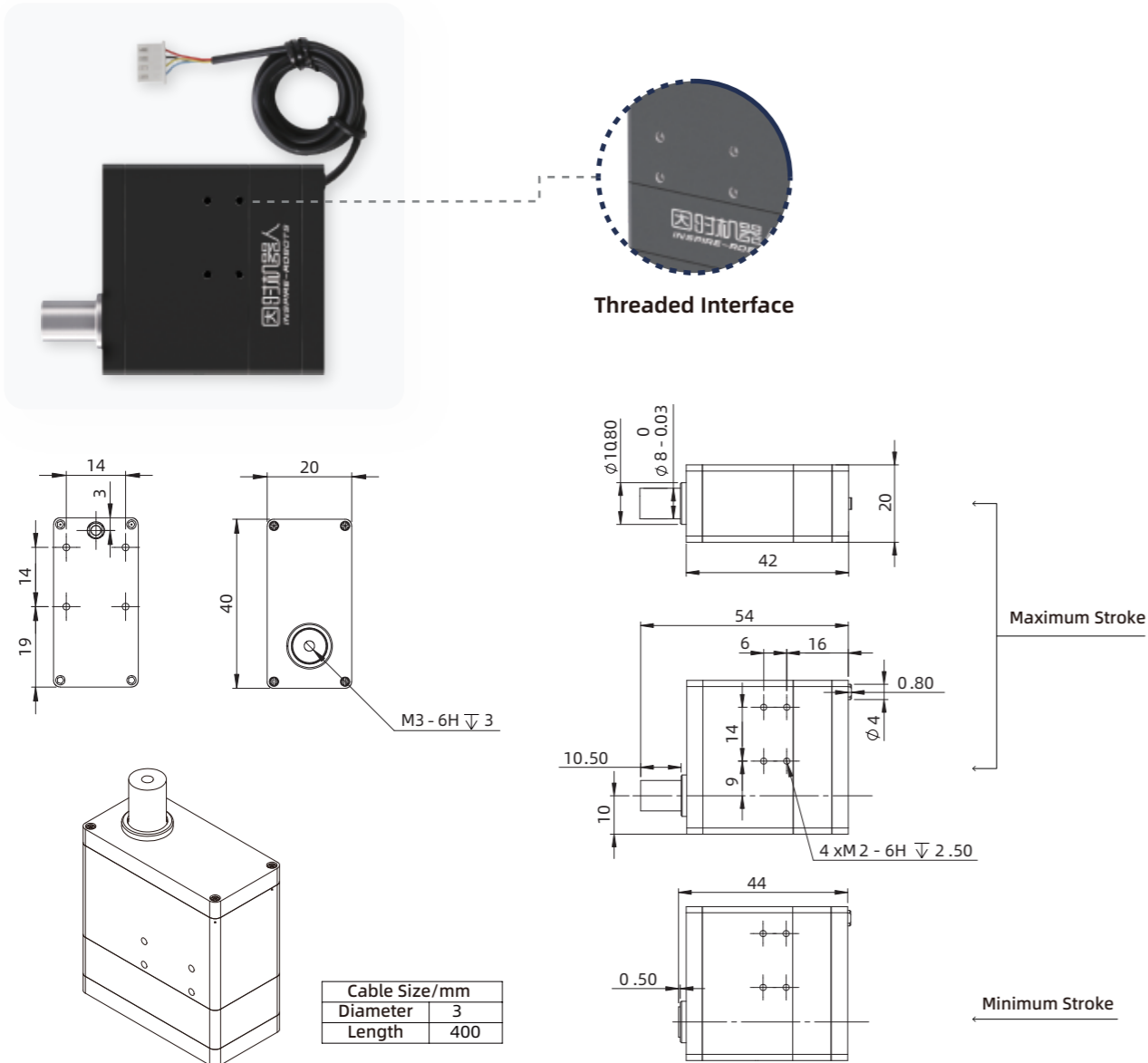

Threaded Interface

BLASF10-C142

Micro Linear Servo Actuator

Standard Parameters

Stroke	Weight	Operating Voltage	Repeatability	Operating Temperature Range	Quiescent Current	Peak Current	Force Sensor Detection Range	Force Sensor Resolution	IP Level
10mm	93g	DC12V±10%	±0.01mm	-10°C~+60°C	65mA	2A	-200N~+200N	1N	IP40

Associated Parameters

Maximum Force	Locked-Rotor Force	Maximum Self-Locking Force	No-load Speed	Full Load Speed	No-Load Current	Communication interface	Motor
150N	200N	70N	8mm/s	5mm/s	400mA	RS485	Coreless Brushless DC Motors

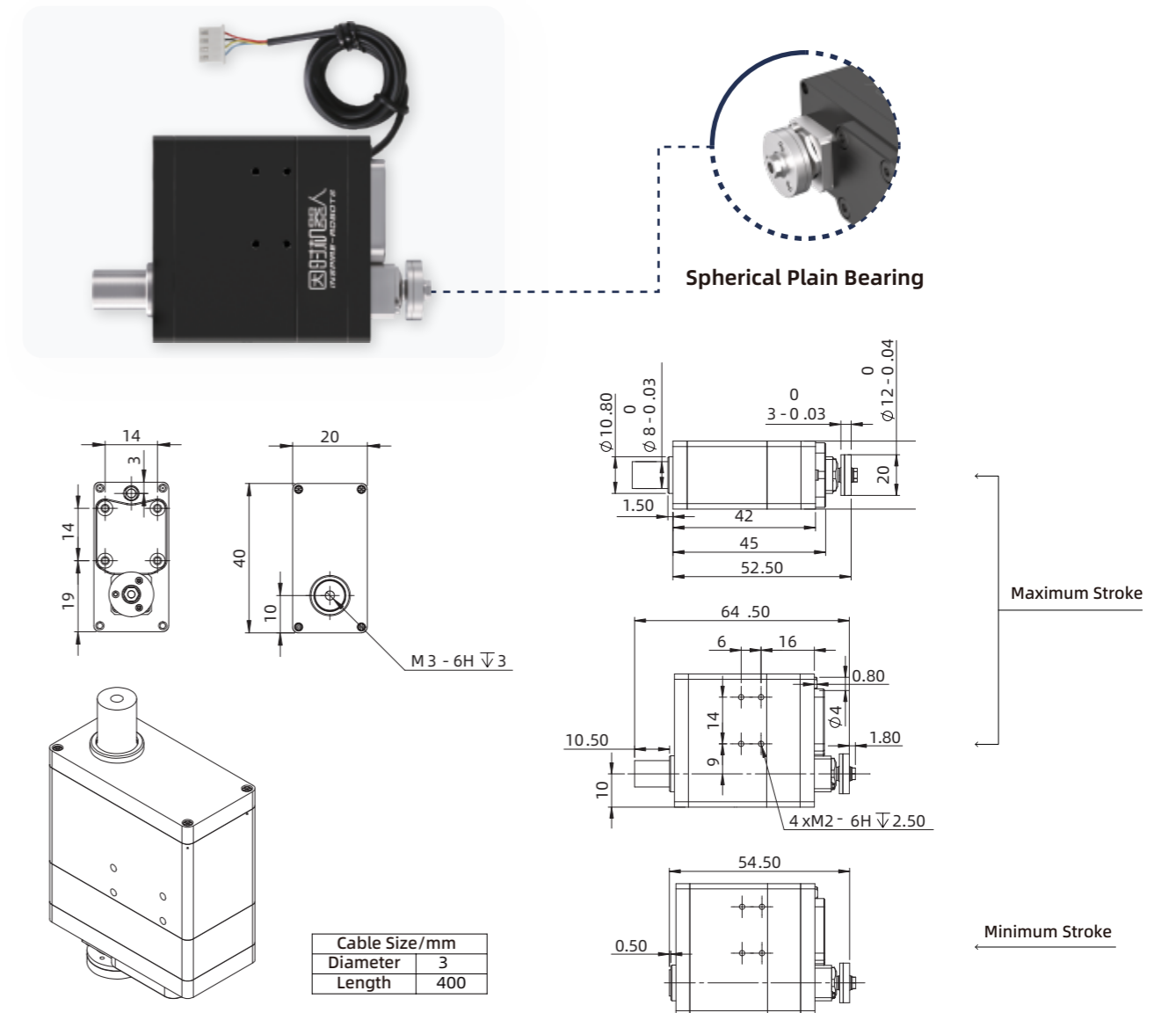

Spherical Plain Bearing Interface

BLAC30-C132

Micro Linear Servo Actuator

Standard Parameters

Stroke	Weight	Operating Voltage	Repeatability	Operating Temperature Range	Quiescent Current	Peak Current	IP level
30mm	113g	DC12V±10%	±0.01mm	-10°C~+60°C	50mA	2A	IP40

Associated Parameters

Maximum Force	Locked-Rotor Force	Maximum Self-Locking Force	No-load Speed	Full Load Speed	No-Load Current	Communication interface	Motor
120N	150N	60N	32mm/s	16mm/s	600mA	RS485	Coreless Brushless DC Motors

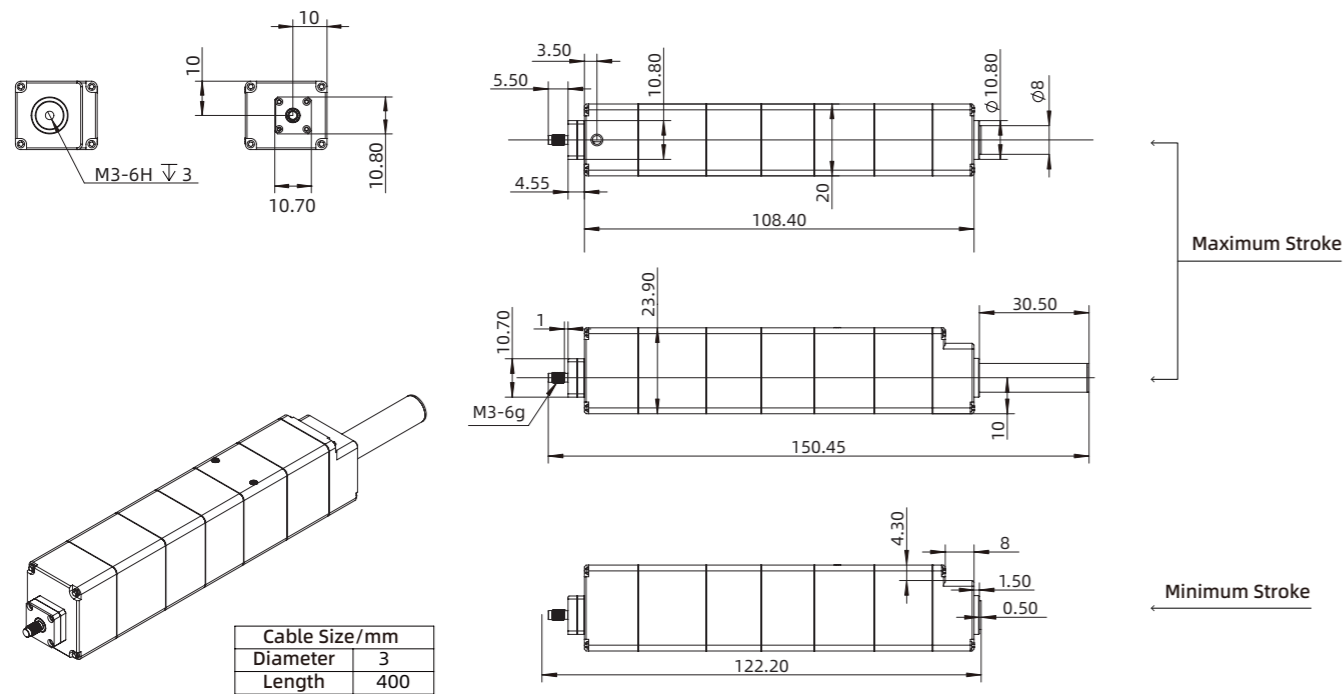
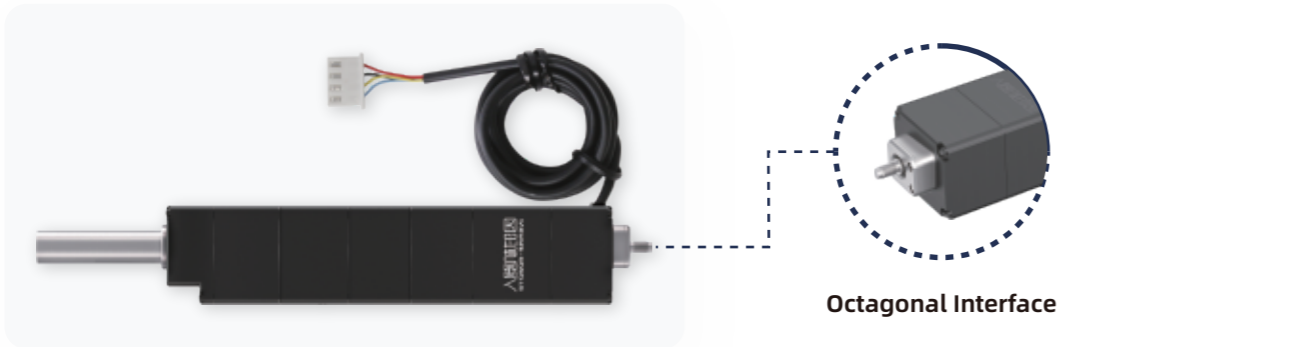

Octagonal Interface

BLACF30-C142

Micro Linear Servo Actuator

Standard Parameters

Stroke	Weight	Operating Voltage	Repeatability	Operating Temperature Range	Quiescent Current	Peak Current	Force Sensor Detection Range	Force Sensor Resolution	IP level
30mm	112g	DC12V±10%	±0.01mm	-10°C~+60°C	65mA	2A	-200N ~+200N	1N	IP40

Associated Parameters

Maximum Force	Locked-Rotor Force	Maximum Self-Locking Force	No-load Speed	Full Load Speed	No-Load Current	Communication interface	Motor
120N	150N	60N	32mm/s	16mm/s	600mA	RS485	Coreless Brushless DC Motors

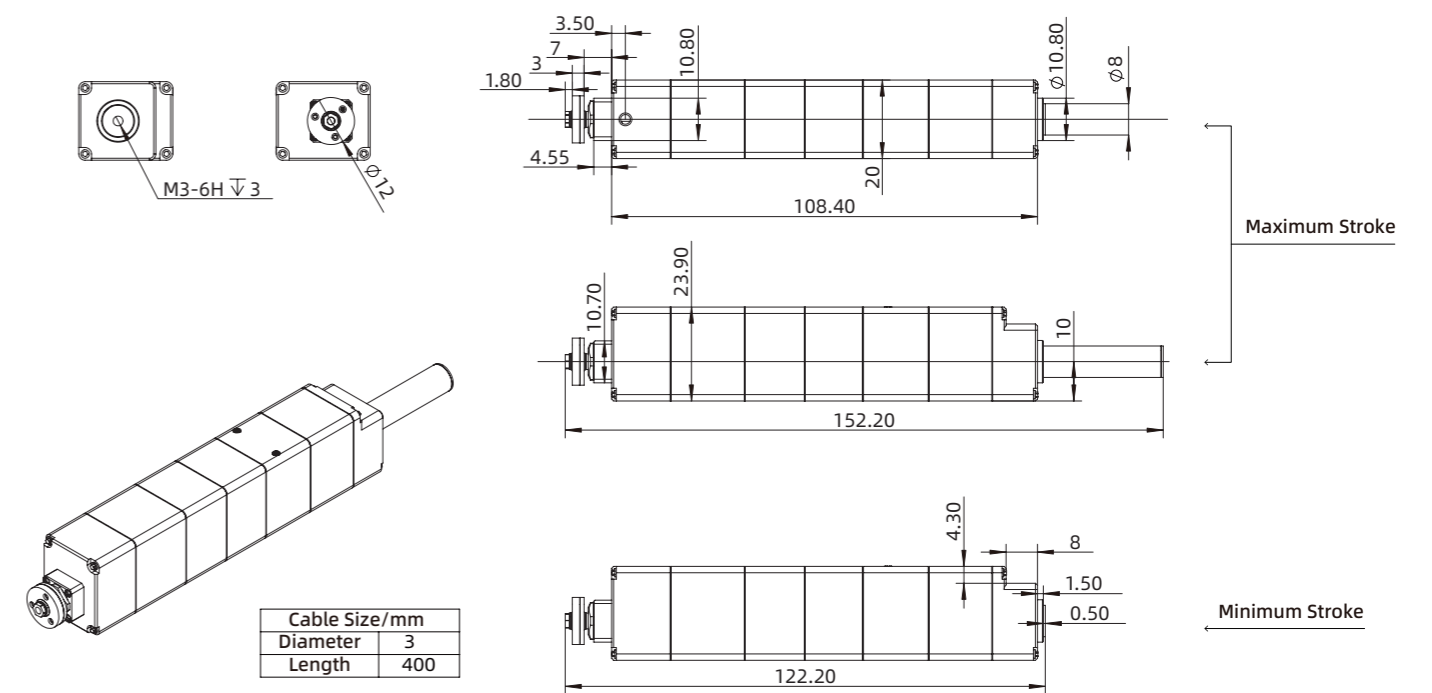

Spherical Plain Bearing Interface

Accessories

Micro Linear Servo Actuator

Octagonal Joint

MODEL : AMI-LA-ACBO-S20/S30/T20/T25/T30

Attention : The octagonal interface comes standard with an AMI-LA-ACBO-S30 octagonal joint, and the installation angle of the octagonal joint can be adjusted as required. In addition to AMI-LA-ACBO-S30, you can also purchase the following types of octagonal joints as needed.



Actuator Joint

MODEL : AMI-LA-ACR1-S20/S30/T20/T25/T30

All models of actuators come standard with M3 standard internal thread, with a depth of 3mm, and actuator joint can be selected as required.



Ball Joint

MODEL : AMI-LA-BR-P30

The front end of the actuator joint can also be equipped with a ball joint if needed. The ball joint have to be used with the actuator joint AMI-LA-ACR1-T30.

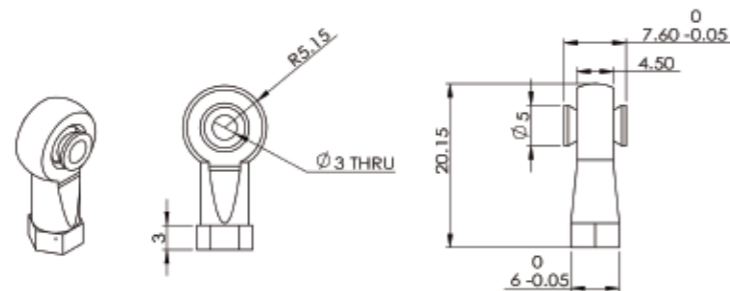

Dimensions of ball joint AMI-LA-BR-P30

Accessories

Micro Linear Servo Actuator

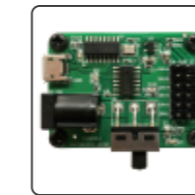

USB to LVTTTL Converter

MODEL : AES-LA-31-06 DIMENSIONS : 45X33X32MM

AES-LA-31-06 Converter converts USB signal input to LVTTTL 3.3V signal output, enabling drive control, parameter modification, and status query. Can connect to six micro linear servo actuators with different IDs.

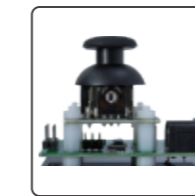

Joystick Controller

MODEL : AEC-LA-B1-02 DIMENSIONS : 60X30X50MM

AEC-LA-B1-02 Joystick Controller enables micro linear servo actuator control in two modes: manual joystick control and autonomous reciprocating motion.

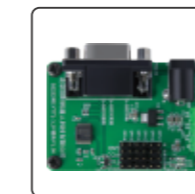

RS232 to LVTTTL Converter

MODEL : AES-LA-11-06 DIMENSIONS : 60X40X35MM

AES-LA-11-06 Converter converts RS232 level signal to LVTTTL 3.3V level signal to enable actuator control via RS232 Serial Port Signal.

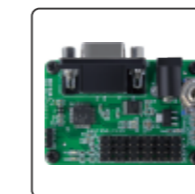

STM32 Controller

MODEL : AES-LA-71-0C DIMENSIONS : 60X40X50MM

AES-LA-71-0C is a STM32F103C8T6 controller with RS232 input and 12 channel LVTTTL 3.3V output, capable of simultaneous control for up to 12 micro linear actuators.

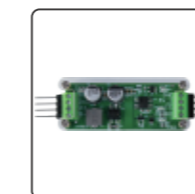

RS485 to LVTTTL Converter

MODEL : AED-LA-82-12 DIMENSIONS : 50X20X25MM

AED-LA-82-12 Converter converts RS485 level to LVTTTL 3.3V level for RS485 micro linear servo control, and/or acting as a 24V to 8V step-down module.

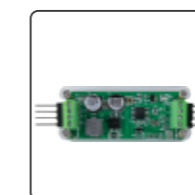

Modbus RTU to LVTTTL Converter

MODEL : AED-LA-92-12 DIMENSIONS : 50X20X25MM

AED-LA-92-12 Converter converts RS485 level to LVTTTL 3.3V level for RS485 servo control via Modbus RTU standard protocol, and/or acting as a 24V to 8V step-down module.

THE DEXTEROUS HANDS

The Dexterous Hands features an innovative linear drive design with six micro linear servo actuator inside. Highly simulated appearance, combined with Hybrid Position and Force Control Algorithm, with sub-millimeter-level positioning accuracy and kilograms of load capacity, can simulate human hands to achieve accurate grasping operation.

APPLICATIONS



Welcome Reception



Unmanned Retail



Building Services



Family Service

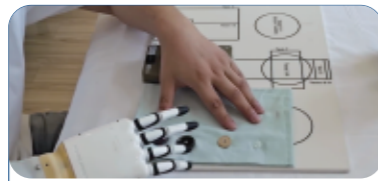

Elderly and Disabled Help



Special Industries



RH56BFX

The Dexterous Hands

RH56BFX series, known as "the Pianist", features high movement speed, integrated force sensor, and slightly reduced grip force, suitable for gesture interactions including piano playing. Support ROS, ROS plug-ins available.

Model	RH56BFX-2L	RH56BFX-2R
Side	The left hand	The right hand
Control interface	RS485	RS485
Degrees of freedom	6	6
Numbers of joints	12	12
Weight	540g	540g
Operating voltage	DC24V±10%	DC24V±10%
Quiescent current	0.20A	0.20A
Peak current	2A	2A
Repeatability	±0.20mm	±0.20mm
Maximum thumb grip	6N	6N
Maximum palm finger grip	4N	4N
Force resolution	0.50N	0.50N
Thumb lateral rotation range	> 65°	> 65°
Thumb lateral rotation speed	235°/s	235°/s
Thumb bend speed	150°/s	150°/s
Palm finger bend speed	570°/s	570°/s

RH56DFX

The Dexterous Hands

RH56DFX series features strong grip, integrated force sensor, and moderate speed, suitable for grasping operations for robots and prosthetics. Support ROS, ROS plug-ins available.

Model	RH56DFX-2L	RH56DFX-2R
Side	The left hand	The right hand
Control interface	RS485	RS485
Degrees of freedom	6	6
Numbers of joints	12	12
Weight	540g	540g
Operating voltage	DC24V±10%	DC24V±10%
Quiescent current	0.2A	0.2A
Peak current	2A	2A
Repeatability	±0.2mm	±0.2mm
Maximum thumb grip	15N	15N
Maximum palm finger grip	10N	10N
Force resolution	0.5N	0.5N
Thumb lateral rotation range	> 65°	> 65°
Thumb lateral rotation speed	107°/s	107°/s
Thumb bend speed	70°/s	70°/s
Palm finger bend speed	260°/s	260°/s

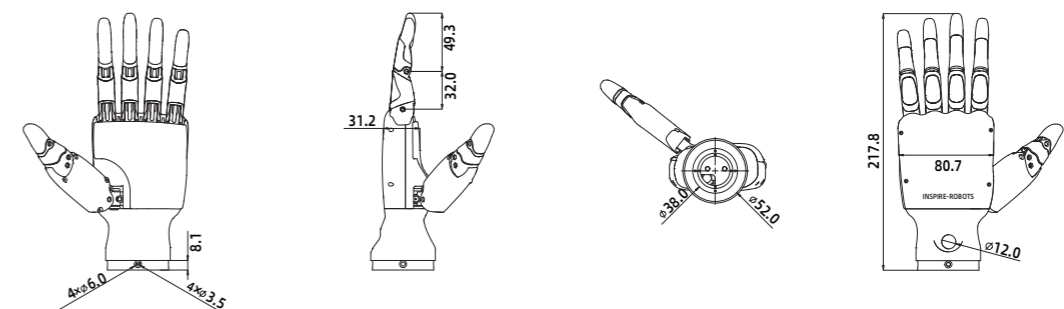

The Dexterous Hands Dimensions

EG2-1C2

Electric Gripper



Features: Flexible gripping, compact structure, five-sided flexible installation, controller integrated design, fast, efficient, high force repeatability.

Model	EG2-1C2
Communication interface	RS485 (Modbus RTU) /IO
Full stroke (both side)	0-12mm
Weight	150g
Grip force	2-30N
Force repeatability	±0.20N
Operating voltage	DC24V±10%
Idling current	0.03A
Peak current	0.80A
Positioning repeatability	± 0.01mm
Full stroke closing time	0.12S
Unloaded current	0.04A
Protection level	IP40
Recommended working temperature	0-40°C, Below 85%RH
Size	84.20*30*18mm

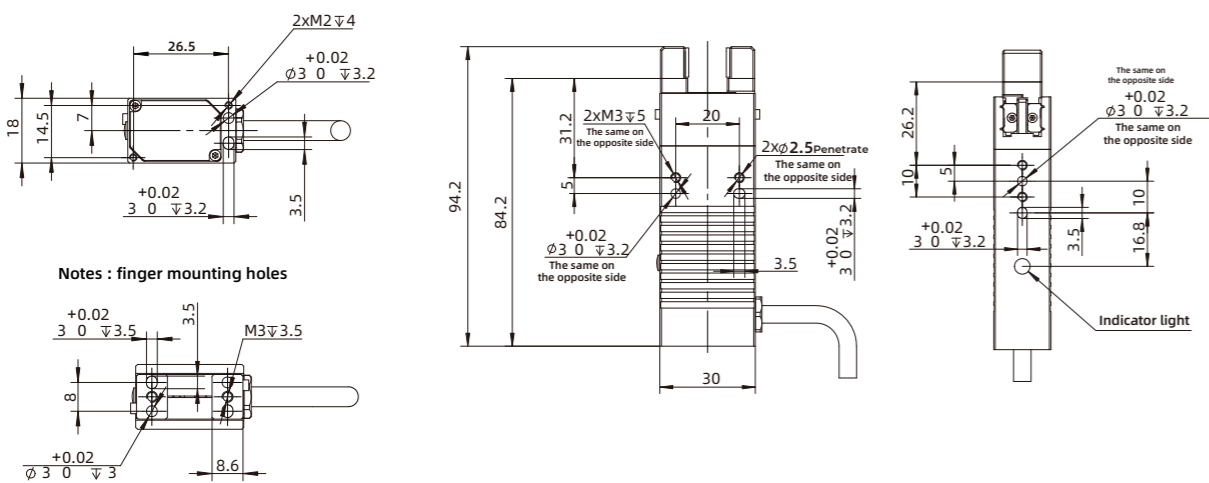

EG2-4B2

Electric Gripper



Features: Innovative linear mechanical linkage design, force and position control, large stroke, light weight, power off self-locking.

Model	EG2-4B2
Communication interface	RS485
Full stroke (both side)	70mm
Weight	223g
Grip force	0-15N
Force repeatability	±1N
Operating voltage	DC24V±10%
Idling current	30mA
Peak current	0.70A
Positioning repeatability	± 0.50mm
Full stroke closing time	0.85s
Unloaded current	200mA
Protection level	IP40
Recommended working temperature	0-40°C
Maximum speed	97mm/s

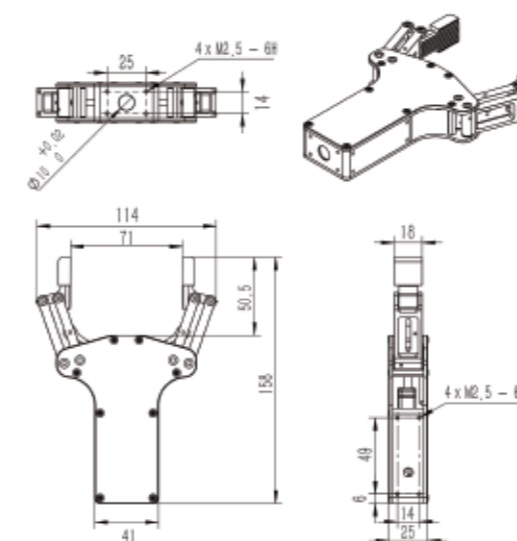

EG2-4C2

Electric Gripper

Features: Innovative linear mechanical linkage design, force and position control, large stroke, light weight, power off self-locking.

Model	EG2-4C2
Communication interface	RS485
Full stroke (both side)	70mm
Weight	231g
Grip force	0-20N
Force repeatability	±1N
Operating voltage	DC24V±10%
Idling current	30mA
Peak current	0.70A
Positioning repeatability	± 0.50mm
Full stroke closing time	1.3s
Unloaded current	200mA
Protection level	IP40
Recommended working temperature	0-40°C
Maximum speed	70mm/s

