

DIABLO

V1.2

User Manual



Safety Notice



Legal Notice

Before using this product, please read the User Manual carefully and operate the product accordingly. If any property damage or personal injury occurs as a consequence of not following the instructions in this User Manual while using the product, the company will not assume any responsibility.

We have made every effort to include the descriptions of various functions and the product's usage instructions in this Manual. However, due to the continuous iteration of the product, there may be discrepancies between the User Manual and the actual product purchased by the user. Users who require the latest version of the User Manual should contact with customer service to obtain a download link.

The color and look of the drawings in this Manual may differ from the real product. Please refer to the actual product.



Usage Restrictions

Before using this product, make sure that you are familiar with its functions and operating procedures.

It is unsuitable for: This product should not be used by persons with physical, sensory, or intellectual disabilities and persons without relevant experience and knowledge (including minors under the age of 18). Children under the age of 14 are prohibited from operating this product; Minors between the ages of 14 and 18 shall be accompanied by an adult guardian when using DIABLO.

Operating environment: Do not use this product in harsh environments such as high temperatures, high pressure, humidity, sand, rain, and snow. Please use this product in a safe and open environment.

Note for cleaning: This product cannot be washed with water, stains should be wiped off with a clean rag.



Safety check

Please check the product carefully before using. If any damage is discovered, do not use it and contact with customer service immediately.

After turning on the product, please check whether it is fully charged, if not, we recommend charging it to full capacity before use.

If the robot cannot function properly in standing mode and it is not due to the site or human factors, the user can refer to the chapter4 for trouble shooting.

Contents

1 Safety Precautions	1
1.1 Precautions for use	1
1.2 Battery and charging	2
1.3 Storage and transportation	3
1.4 Use DIABLO legally	3
1.5 FCC Statement	4
2 Introduction of DIABLO	5
2.1 Package contents	6
2.2 Description of parts	6
2.3 Product specifications	7
3 Instructions for Use	10
3.1 Prepare to turn on the robot	10
3.2 Description of the remote control	10
3.3 Operating instruction	14
3.4 Instructions for shutting down the robot	17
3.5 Instructions for charging	17
4 Description of the robot	18
4.1 Description of tail lights	18
4.2 Description of the detachable upper cover	19

1 Safety Precautions

1.1 Precautions for use

- a. Before use, **please ensure that you have carefully read the "DIABLO User Manual" and the "Safety Precautions"** and have a sufficient understanding of this robot. If unsafe conditions such as slipping, falling, or losing control occur, please immediately stop using and follow the steps on the "Emergency Stop Procedure Card". If you have any questions, please contact with customer service immediately.
- b. Children under the age of 14 are prohibited from operating DIABLO. Minors between the age of 14 and 18 should be accompanied by an adult guardian when using DIABLO.
- c. **DIABLO can only be used in an open area and must be away from inflammables or heat sources. While in use, please always keep DIABLO within your sight and away from crowds, obstacles, and other objects that it might collide with and cause damage. Do not use DIABLO on crowded streets, for it may cause injury to others.**
- d. It is prohibited to use DIABLO in rainy or snowy conditions or wading through water, and it must not come into contact with liquid. To avoid user injury or damage to DIABLO, it is strictly prohibited to turn on the power immediately after the robot is drenched with rain or water. **If your DIABLO accidentally gets wet, stop it immediately, press the emergency stop switch, and wipe it down with a soft dry cloth right away.**
- e. Please use the battery and adapter included in the box correctly. It is prohibited to use chargers other than that supplied by the factory. If you have any questions, please get in touch with customer service immediately.
- f. Please ensure that DIABLO has sufficient power. It is prohibited to operate DIABLO while charging. If the warning light on the tail of DIABLO illuminates, please do not use or immediately stop using DIABLO.
- g. In order to prevent batteries from being over-discharged and maximise battery life, we recommend recharging batteries every 3 months to maintain performance. The batteries shall not be sit unused for more than 3 months. Sitting unused for more than 3 months may cause damage to the batteries and in this case we will not provide any warranty service for the batteries.
- h. Please immediately cease using the DIABLO and get in touch with customer service if the joints actuators are affected by sharp objects, overheating, loose structure, broken wiring harness, damaged tires, strange noises, excessive running noise, or any other anomalous circumstances.

- i. Do not operate DIABLO on terrain that challenges its terrain adaptive capabilities to the extreme or use it on complex terrains, such as stepping on it or lying it on hard, sharp, uneven ground or dragging it sideways, etc.; such actions could cause the outer layer of the tire to wear out or cause DIABLO to turn over and get damaged.
- j. Do not operate DIABLO on slippery ground, such as a wet tiled floor, to avoid damage to the body of the robot.
- k. **To avoid injury, do not put your hands into DIABLO's body, the connection points between its joints, or the gaps between its legs, and do not touch the joint motors.**
- l. **It is prohibited to place any part of your body or valuables directly under DIABLO.**
- m. **When the robot is used for a long time and the system is overheated, please stop using the system immediately and shut down for 15 minutes. During this period, it is forbidden to touch the robot.**
- n. If your DIABLO accidentally comes into contact with sand, soil, vegetation, dirty water, etc., please clean it up immediately after use.
- o. When pressing the emergency stop switch, please grasp the handle tightly to avoid DIABLO being suddenly deactivated and losing control.
- p. **DIABLO's maximum weight-bearing capability is 4 kg in standing mode and 80 kg in creeping mode. When placing items on top of DIABLO, please make sure the items are secure to avoid property damage. To prevent damaging the loaded items, it is prohibited to use the emergency stop function while the robot is carrying a load.**
- q. When DIABLO is in a half-creeping mode and carries a load of more than 5 kg, the automatic battery protection might be triggered. DIABLO will directly enter the power-off protection state, and the user should press the emergency stop switch immediately.
- r. **DIABLO is not designed to transport people; to avoid injury, no one is allowed to ride on it.**
- s. After use, please make sure DIABLO is shut down and stored properly.
- t. Avoid using this product in a heavy statics environment. The company does not assume any responsibility for the unstable frequency of the receiver caused by heavy statics.

1.2 Battery and charging

- a. Please correctly use the battery and adapter included in the package.

- b. When charging the battery, please place the battery charging station and the power adapter in a flat, dry, and cool place, away from flammables or heat sources, and do not touch the power adapter.
- c. It is prohibited to operate DIABLO while charging. Before charging, please ensure that DIABLO is shut down or in a deactivated state.
- d. It is prohibited to operate DIABLO while charging. Before charging, please ensure that DIABLO is shut down or in a deactivated state.
- e. The ambient temperature for charging is 0-45°C.
- f. To prevent the risk of electric shock, it is strictly prohibited to immerse wires, plugs, and other parts of DIABLO in water or other liquids.
- g. In order to avoid fire or other damage caused by improper operation, make sure you have carefully read the instructions (precautions) of the battery and the adapter before charging.

1.3 Storage and transportation

- a. DIABLO should be stored in a dry and cool environment, away from direct sunlight, flammable substances, fire sources, and strong electromagnetic environments.
- b. Please use the handle when transporting DIABLO. Do not pull the wiring harness, and handle it with care; avoid dropping or throwing, which may damage its parts.

1.4 Use DIABLO legally

- a. It is prohibited to use this product for any illegal, criminal, or inappropriate activities (including but not limited to espionage, military operations, illegal investigations, etc.).
- b. It is prohibited to use this product to infringe on the privacy of others and any other personal and property rights.
- c. It is prohibited to send DIABLO into the vicinity of sensitive buildings and facilities. These may include national borders, power stations, substations, prisons, traffic arteries, railway and road transportation hubs, government buildings, military bases, facilities, etc.
- d. **Robots will be used in the manner permitted by local laws if the rules and regulations of the user's region and country permit their use, and the user is required to be aware of and abide by the laws and regulations of the region.**

- e. Note: All obligations deriving from secondary development, alteration, etc. are the user's responsibility.

1.5 FCC Statement

- a. This device complies with part 15 of the FCC Rules. Operation is subject to the following two conditions: (1) This device may not cause harmful interference, and (2) this device must accept any interference received, including interference that may cause undesired operation.

2 Introduction of DIABLO

DIABLO is a super agile & stylish two-wheeled-leg robot and an open development platform.

Powered by 6 M1502D free-moving direct-drive robot joints, the DIABLO boasts high power, smooth action, energy-saving, and high efficiency. Different from the traditional reducer scheme, the DIABLO is extremely quiet during operation and will not cause any noise concerns. Its unique transformation feature allows the robot to combine the agility of a legged robot with the robustness and speed of a wheeled robot.

The open development ecology also provides perfect interfaces for various forms of applications. DIABLO is the perfect carrier whether you need quiet company, stealth patrol, dexterous maneuvers, or smooth transportation.

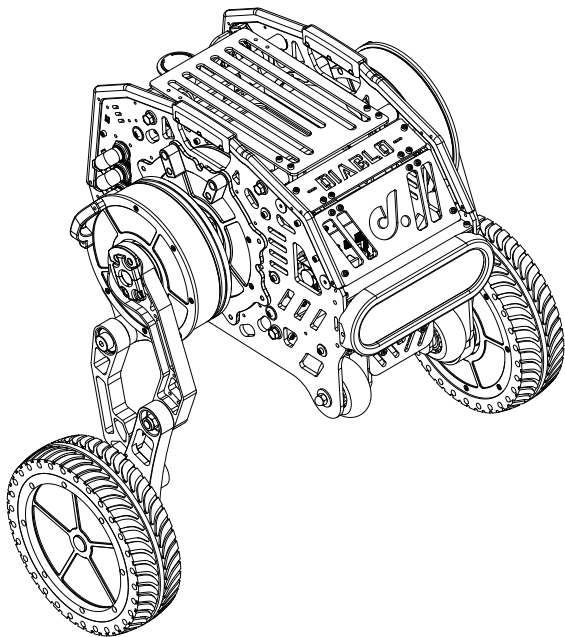

2.1 Package contents

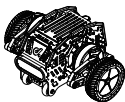

Two-wheeled robot DIABLO × 1

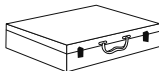

Portable aluminum case × 1



Remote control × 1

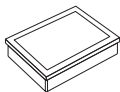

Accessory box × 1



Charger × 1



User manual × 1

Special note: The accessories box contains M2.5 Allen wrench*1, M3 Allen wrench*1, M4 Allen wrench*1, Phillips wrench*1, M3 locking nut*5, M3 square nut*5, M3X20 Screw*5, M3X16 Screw*5, M3X10 Screw*10, M4X15 Screw*5, M3X12 Thumb Screw*5, M6X16 Flange Screw*2, M3X14 Gasket*5, M6X18 Gasket*2, M4 Flange lock nut*5.

2.2 Description of parts

Side view of DIABLO

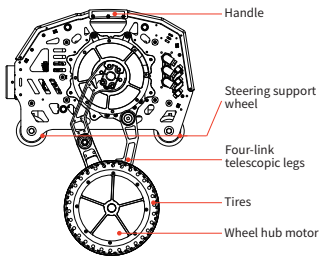

Top view of DIABLO

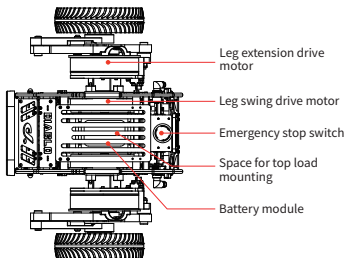

Front view of DIABLO

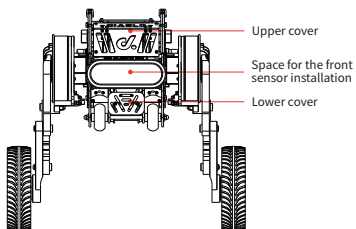

Back view of DIABLO

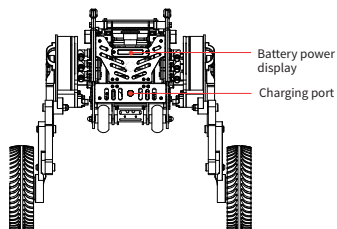

2.3 Product specifications

Power adapter specifications	
Model	XVE126-3290300
Output current	3A
Output voltage	32.9V
Input voltage	110V AC

Motor specifications	
Motor dimensions	$\Phi 144 \times 41.8$
Weight of a single motor	2.3kg
Operating voltage	28-32V
Rated voltage	32V
Stall current	28A

Rated current	12A (non-continuous work)
Rated torque	9.6Nm
Stall torque	20Nm
Rated speed	115rpm
Encoder resolution	15 bits

Robot specifications	
Net weight	22.9KG
Length, width, and height in standing mode	540×371×491mm
Length, width, and height in creeping mode	540×371×270mm
Maximum load in standing mode	4kg
Maximum load in creeping mod	80kg
Noise during operation	<49dB
Standing time in an upright position	The standing time is ≈3h at an ambient temperature of 25 °C.
Maximum continuous travel time in creeping mode	The travel time in creeping mode at high speed is ≈3h at an ambient temperature of 34 °C.
Standing time in half squat state	The standing time is ≈15min at an ambient temperature of 25 °C.
Maximum continuous travel time in standing mode	The travel time at low speed in standing mode is ≈3h at an ambient temperature of 34 °C.
Jumping height	The jumping height is about 8cm with no load

Remote control

Model	RadioLink T8S
Receiver sensitivity	-104dbm
Output frequency	2.4GHz
Maximum safe remote control distance	150m

Battery specifications

Battery type	Li-ion battery
Capacity	6AH
Cycle life	It retains more than 80% of its initial capacity after 1000 cycles

Description of the main control pins

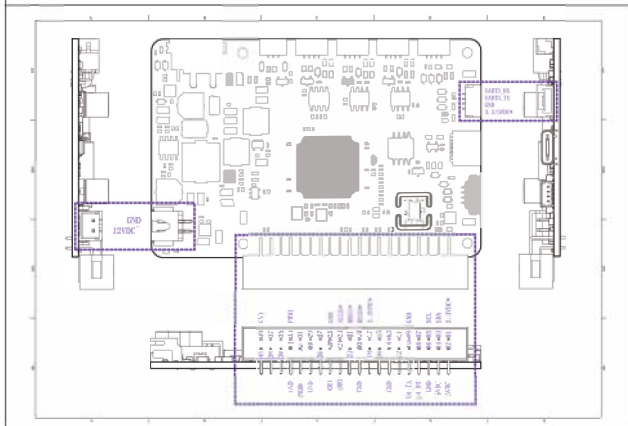

3 Instructions for Use

3.1 Prepare to turn on the robot

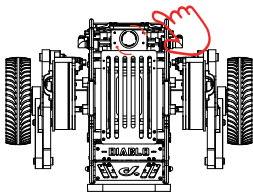

The red emergency stop is rotated clockwise, pulling the left trigger of the remote control down, and pulling the right trigger in the middle, and do not move the joystick of the remote control, after the power indicator light on the tail lights up, the robot is in the power-on state

3.2 Description of the remote control

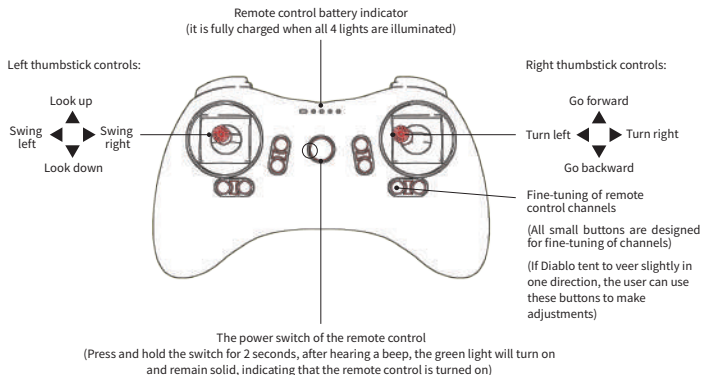

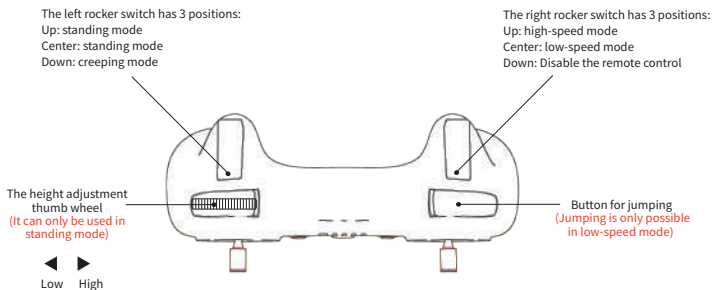

Note: In order to ensure the user's safety, In the creeping mode of the robot, first reset the buttons of the remote control (the left trigger is down, the right trigger is in the middle, the joystick is in the middle, release the jump button), and then the left trigger is in the middle, DIABLO can stand.

(The high-speed mode is a special mode that requires the user to have good controlling skills. The user should pay attention to safety when operating in this mode. It is prohibited to operate DIABLO in a complex road environment, such as one with too many people and vehicles. The user is responsible for any accidents involving equipment and people that occur in this mode)

Switching of rocker's switch position



Description of switch combinations

—first adjust the position of the left rocker switch, then adjust the right one

Left rocker switch	Right rocker switch	Jump key	Status	Remarks
Down	Down	Released	Creeping mode with remote control disabled	Left and right thumbstick, scroll wheel functions disabled
Down	Down	Click and hold for 2 seconds	The motor is in a deactivated state	This state can disable the robot's motor, please use it with caution in the standing mode
Down	Centre	Released	Creeping mode with low-speed movement	The left thumbstick is disabled, and the right thumbstick functions normally
Down	Up	Released	Creeping mode with high-speed movement	The left thumbstick is disabled, and the right thumbstick functions normally

Left rocker switch	Right rocker switch	Jump key	Status	Remarks
Centre	Down	Released	Standing mode with remote control disabled	Left and right thumbsticks disabled
Centre	Centre	Click and hold for 2 seconds	Standing mode with jumped	Left and right thumbstick functions normally
Centre	Up	Released	Standing mode with high-speed movement	Left and right thumbstick functions normally

Note : **In order to ensure the user's safety**, In the creeping mode of the robot, first reset the buttons of the remote control (the left trigger is down, the right trigger is in the middle, the joystick is in the middle, release the jump button), and then the left trigger is in the middle, DIABLO can stand.

Left rocker switch	Right rocker switch	Jump key	Status	Remarks
Up	Down	Released	Standing mode with remote control disabled	Left and right thumbsticks disabled

Note : **In order to ensure the user's safety**, In the creeping mode of the robot, first reset the buttons of the remote control (the left trigger is down, the right trigger is in the middle, the joystick is in the middle, release the jump button), and then the left trigger is in the middle, DIABLO can stand.

3.3 Operating instruction

Creeping mode

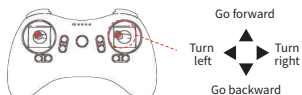
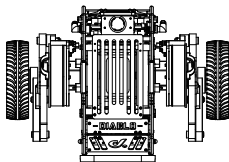

In the creeping mode, the left thumbstick has no function, and the right thumbstick is used to control the forward, backward, turn left, and turn right movements.

In the creeping mode, DIABLO cannot jump and the height cannot be adjusted.

Standing mode

- 1 The transition from creeping mode to standing mode

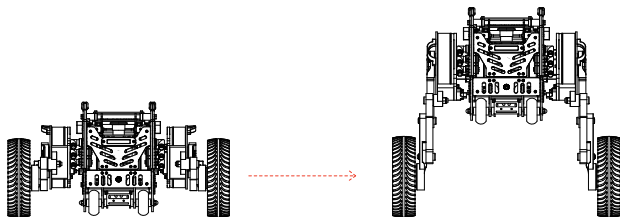

In order to ensure safety, In the creeping mode of the robot, first reset the buttons of the remote control (the left trigger is down, the right trigger is in the middle, the joystick is in the middle, release the jump button), and then the left trigger is in the middle, DIABLO can stand.

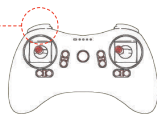

- 2 The right thumbstick is used to control Diablo's traveling status

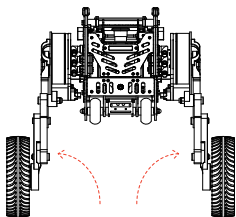

Turn left/turn right

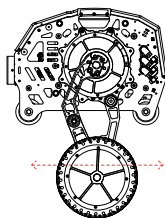

Go forward/backward



Go forward
Turn left
Turn right
Go backward

- 3 The right thumbstick is used to control Diablo's pose

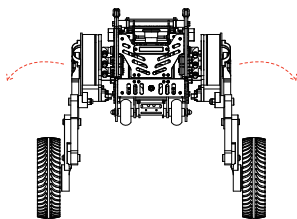

Swing left/right

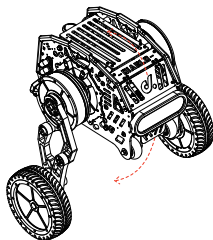

Look up/down

Look up
Swing left
Swing right
Look down



- 4 The height adjustment thumbwheel is used to adjust the height

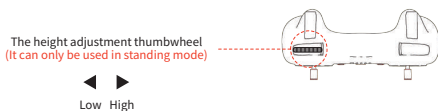
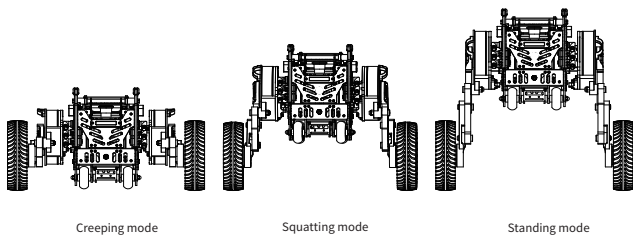

- 5 The jump button is used to make DIABLO jump while in standing mode

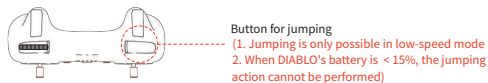
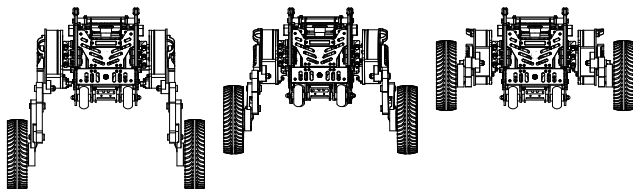

3.4 Instructions for shutting down the robot

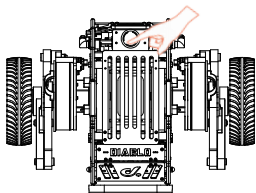

- 1 Press the red emergency stop switch, the tail power indicator light goes out, and Diabolo is turned off.



- 2 Once the light turns off after pressing and holding the remote control power switch for two seconds, the remote control is off.

3.5 Instructions for charging

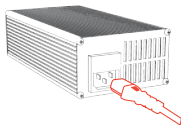

- 1 First, connect the charger to the socket

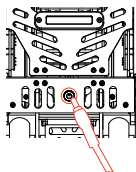

- 2 Then plug the charging cable into the rear charging jack

A red charger display light ● indicates that DIABLO is not fully charged.
A green charger display light ● indicates that DIABLO is fully charged.

Before charging, please ensure that DIABLO is shut down or in a deactivated state

4 Description of the robot status

4.1 Description of tail lights

Battery indicator modes				
All lights are green	Only the seven lights on the left are green	Only the five lights on the left are green	Only the three lights on the left are yellow	Only the one light on the left is red
The battery level is $>80\%$	$80\% \geq$ The battery level $>60\%$	$60\% \geq$ The battery level $>40\%$	$40\% \geq$ The battery level $>20\%$	The battery level is $\leq 20\%$

Charging indicator modes		
All lights are green	Eight lights on the left are green	Seven lights on the left are green
The charging capacity is $>95\%$	$95\% \geq$ The charging capacity $>80\%$	$80\% \geq$ The charging capacity $>60\%$

Five lights on the left are green	Three lights on the left are green	One light on the left is green
$60\% \geq$ The charging capacity $>40\%$	$40\% \geq$ The charging capacity $>20\%$	The charging capacity is $\leq 20\%$

Fault code indicator mode			
The indicator light is all yellow and flashes slowly (once every 2 seconds)	The indicator light is all yellow and flashes quickly (twice every 1 second)	The indicator light is all red and flashes slowly (once every 2 seconds)	The indicator light is all red and flashes quickly (twice every 1 second)
Robot disability warning, wheel over speed warning	Motor warning, battery offline	Parameter error, leg overload	Motor communication disconnection error, motor failure error

Note: DIABLO enters the fault code indication mode only when the aforementioned scenarios occur, to assist you in better operating the robot and determining the source of the fault. If a robot warning occurs, the warning can be cleared by disability and resetting the robot. If DIABLO fails to activate the fault code indication mode, please contact us.

4.2 Description of the detachable upper cover

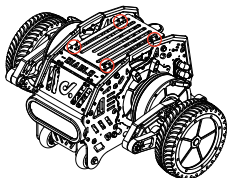

- 1 Use an M3 wrench to remove the 8 screws from the upper cover

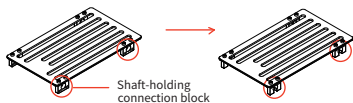

Shaft-holding connection block

- 2 Remove the Shaft-holding connection block and use the screws just removed to reverse install the holding shaft connection block in the upper cover plate (the notch faces away from the upper cover)

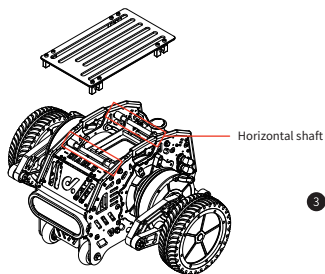

Horizontal shaft

- 3 Align the notch position of the shaft-holding connection block with the upper horizontal shaft on the robot, press down firmly, and snap the upper cover into the robot

Email: hello@directdrivetech.com

Direct Drive Technology Limited

Address: Unit 983, 9/F Building 19W No. 19 Science Park West
Avenue Hong Kong Science Park, Pak Shek Kok

Manufacturer: DongGuan Direct Drive Limited

Address: No. 206, 207, 208, 2nd Floor, Building 3, South District,
Digital Technology Industrial Park, CIMC Industrial City, No.1,
Yile Road, Songshan Lake High-tech Development Zone,
Dongguan, Guangdong Province, China

Notice: Please scan the code to get
the operation demonstration video.



Operation Demonstration
Video