

- 1 ALL DIMENSIONS ARE IN mm
- 2 MASS WITHOUT TOP TRAY AND BATTERIES: 100kg (220 lb)
- 3 AUXILIARY POWER INTERFACE PN "Anderson Power Products 992G7-BK"  
24V UNREGULATED, MAX CURRENT 30A, MAX CONTINOUS CURRENT 15A
- 4 RETAINER PN "SOUTHCO-D8-339-400-121"
- 5 INTERFACE USB3.0 TYPE A
- 6 MAX SLOPE WHEN EMPTY: 25 DEGREES
- 7 FLAT SMOOTH TERRAIN  
MAX PAYLOAD : 225kg (500 lb)  
MAX PAYLOAD CG HEIGHT FROM GROUND: 620 mm
- 8 RECOMMENDED PAYLOAD  
MAX PAYLOAD : 150kg (330 lb)

	PROJECT			
	<b>Burro</b>			
	TITLE			
	<b>Gen8 Interface</b>			
APPROVED	SIZE	CODE	DWG NO	REV
CHECKED	B			B
DRAWN	Stephen Jablonski 5/4/2022	SCALE	WEIGHT	SHEET 1/4

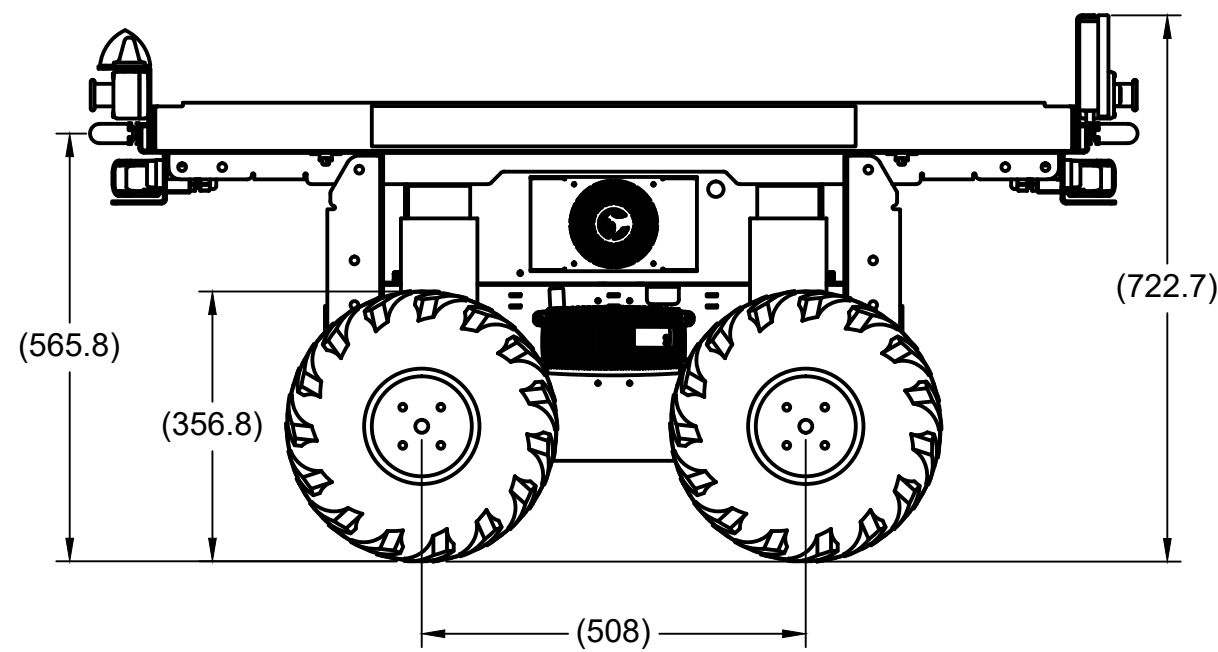

		PROJECT <b>Burro</b>		
		TITLE <b>Gen8 Interface</b>		
APPROVED	SIZE	CODE	DWG NO	REV
CHECKED	B			B
DRAWN	Stephen Jablonski 5/4/2022	SCALE 1:10	WEIGHT	SHEET 2/4

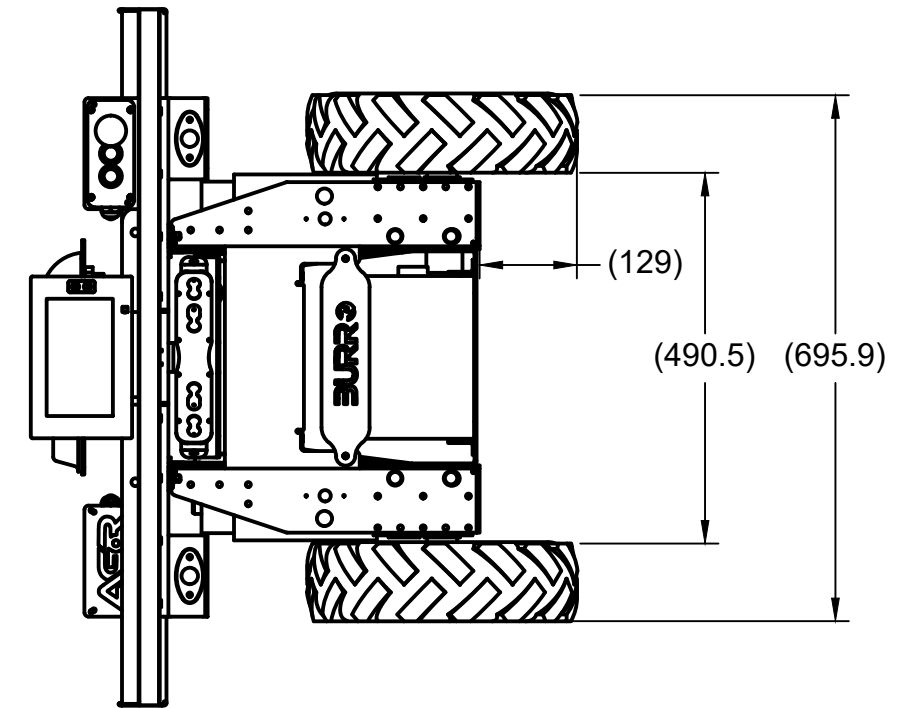
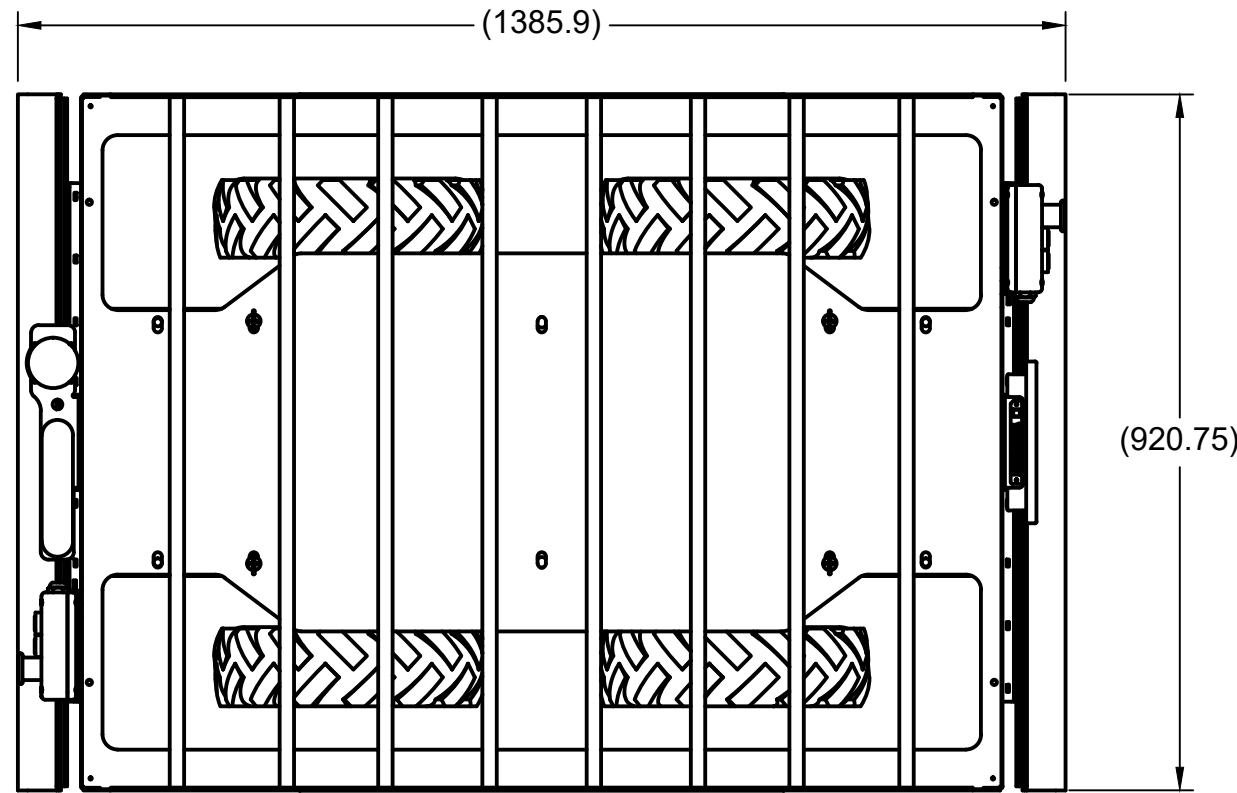
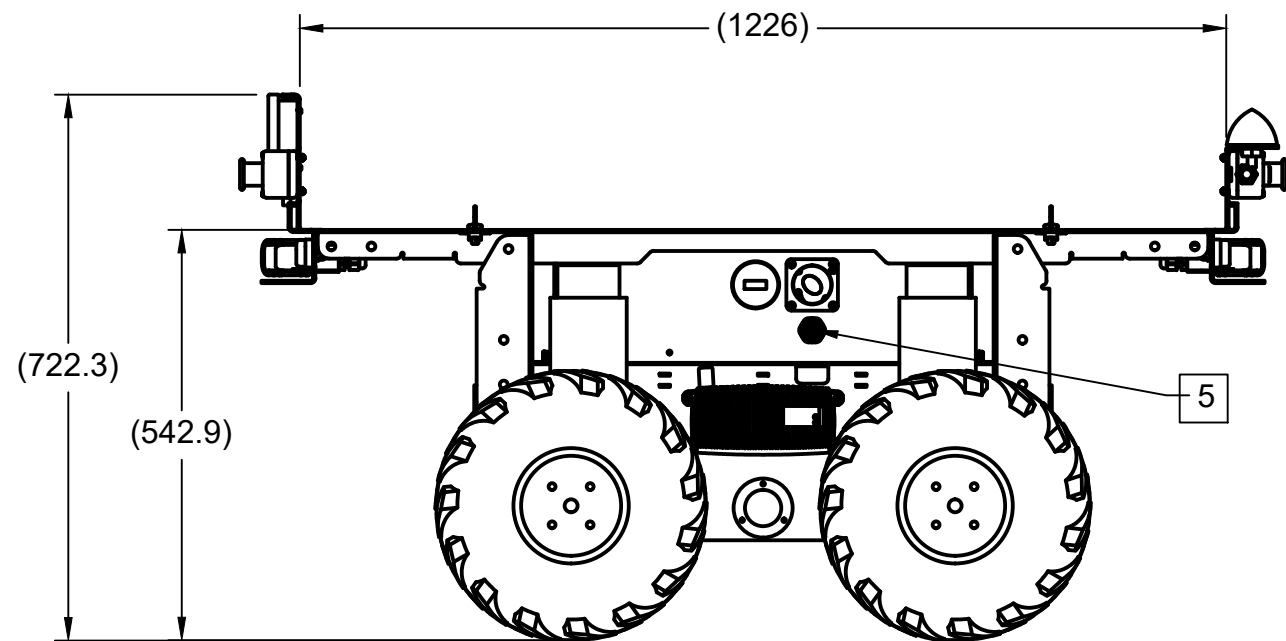
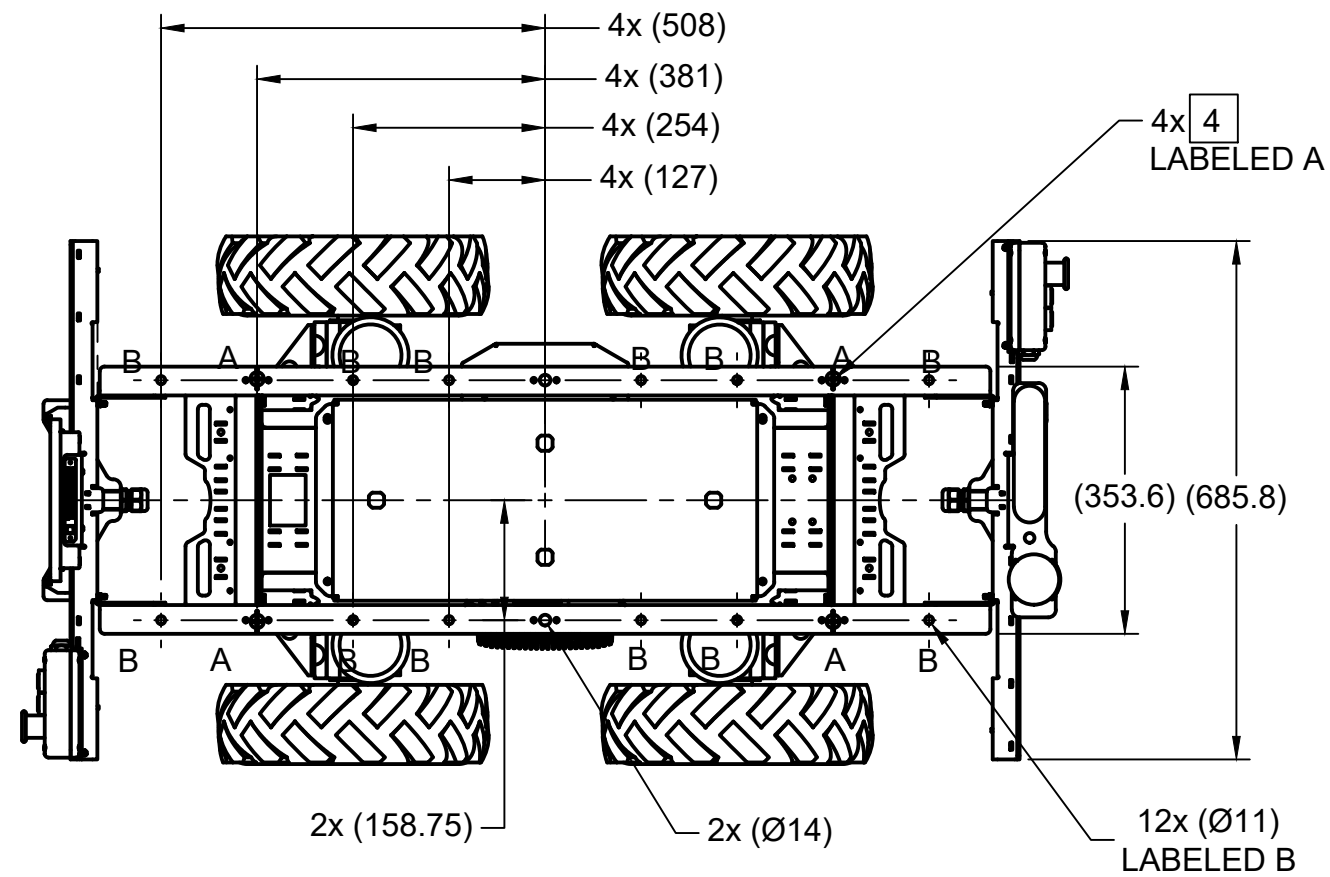

TOP TRAY AND BUMPER SENSORS  
HIDDEN FOR CLARITY

		PROJECT <b>Burro</b>		
		TITLE <b>Gen8 Interface</b>		
APPROVED	SIZE	CODE	DWG NO	REV
CHECKED	B			B
DRAWN	Stephen Jablonski 5/4/2022	SCALE 1:10	WEIGHT	SHEET 3/4

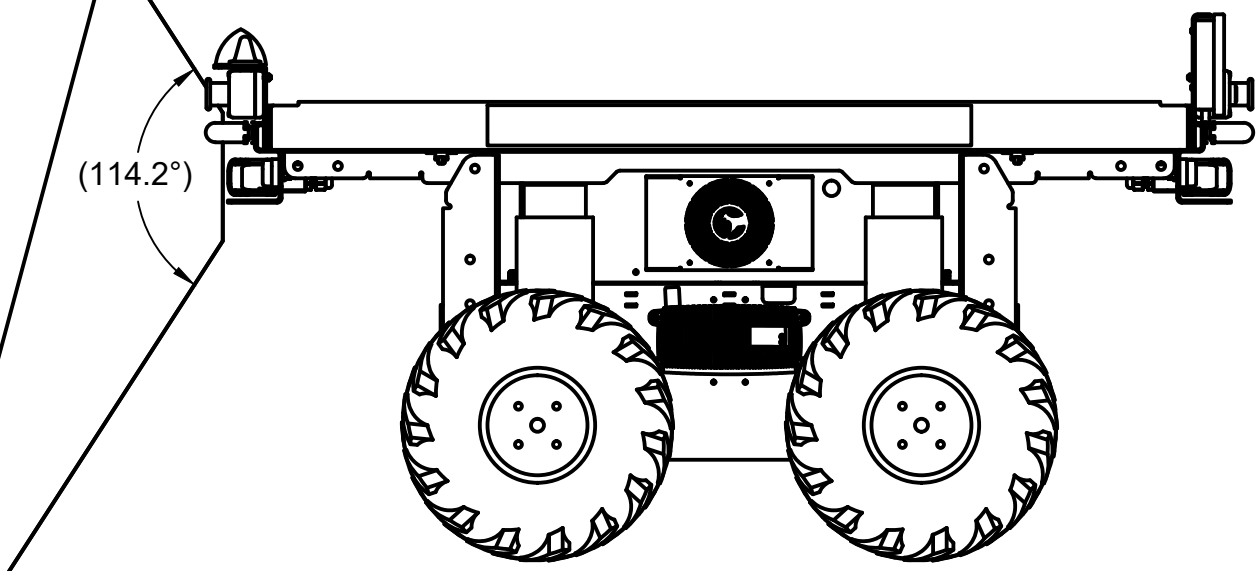
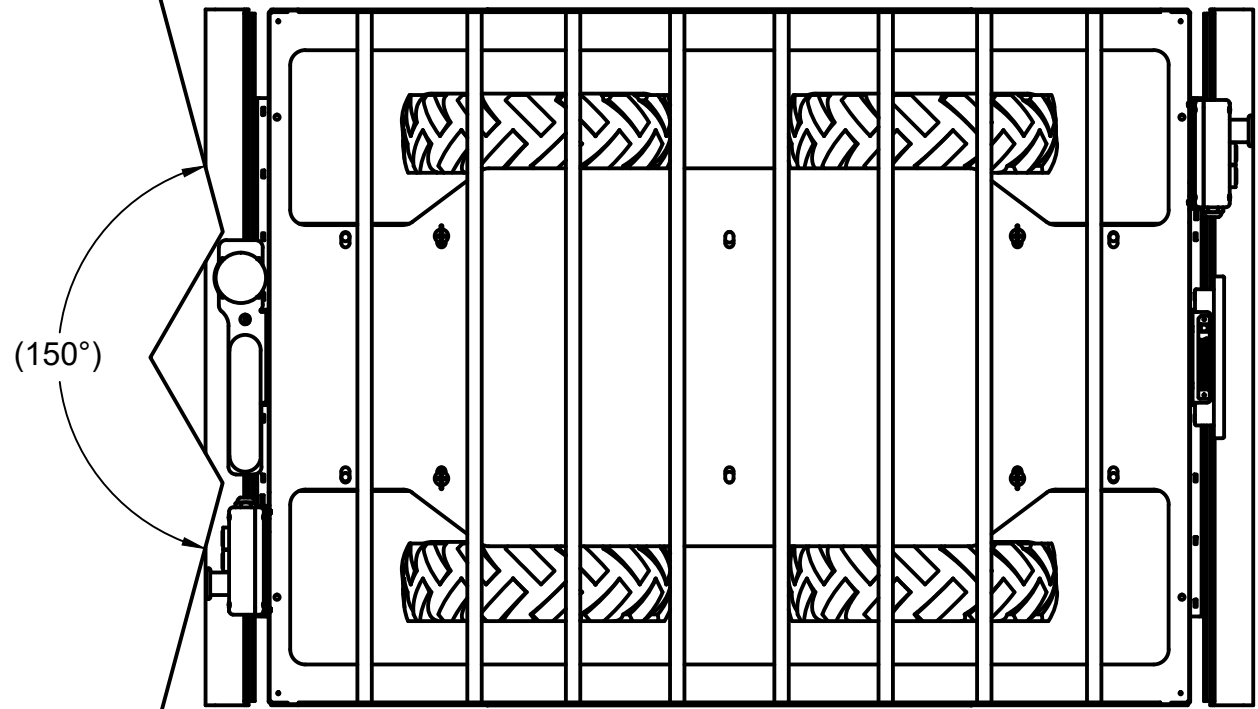

**FIELD OF VIEW  
BOTH SIDES**

		PROJECT <b>Burro</b>		
		TITLE <b>Gen8 Interface</b>		
APPROVED	SIZE	CODE	DWG NO	REV
CHECKED	B			B
DRAWN	Stephen Jablonski 5/4/2022	SCALE 1:10	WEIGHT	SHEET 4/4