

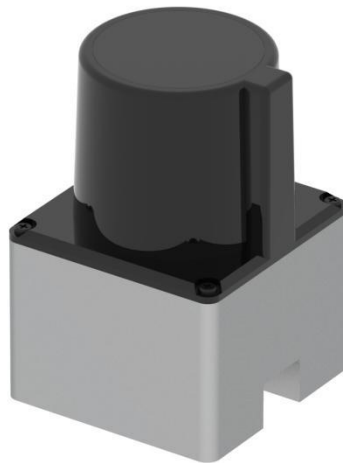

VP300 2D Lidar/Laser Distance Sensor

User Manual & Specification Sheet



Contents

Product overview.....	3
Main Parameters.....	4
Model Catalog	4
Setup Instruction.....	4
Installation	5
Electrical Interface	5
Use Manual	6
Prep Before Use	6
Software instruction.....	7
Start Lidar.....	8
Sizes and Dimensions.....	9
Appendix Revision History.....	9

Product overview

VP300 is a 2D lidar product developed by Nvistar Technology. The Lidar applies Pulsed ToF (Pulsed ToF) for distance measurement. Its internal structure adopts a rotating lens design, that is, the invisible infrared laser emitted by the ranging module is deflected to different angles through a high-speed rotating lens, so as to realize the scanning measurement of the environmental profile horizontally (Scan Angle 300°). VP300 can output 20K point cloud data per second, and can reach a maximum range of 50 meters. It uses 905nm infrared laser, with Nvistar self-developed signal processing algorithm. The product is dustproof and waterproof IP65, suitable for various outdoor applications.

Product Features

- ◆ Long distance, high precision. Due to the principle of pulse ranging and the optimization of photoelectric design, VP300 has a longer measurement distance, and the full range accuracy can be guaranteed within +/-3cm, which is very suitable for use in large spaces.
- ◆ High rotation frequency, low noise. VP300 rotates a customized lens to scan. The rotating part is only a weightless mirror, so it can reach a high frequency of 30HZ, and it can be expanded to 50HZ according to needs. At the same time, it can maintain extremely low noise during operation, which is almost inaudible to human ears.
- ◆ High reliability and excellent compatibility. The rotating mirror design reduces the number of moving parts inside Lidar, increases the service life of the product and greatly reduces the impact of mechanical vibration on operation. In addition, VP300 adopts micro-USB interface design, which can switch UART and Ethernet ports flexibly.
- ◆ Small size and light weight. The height of the lidar body is less than 7.5 cm and the side length of the base is only 5 cm, which is convenient for installation in limited space.

Main Parameters

- Laser wavelength: 905nm, class I safety
- Scan range: From Min. 0.1m to 15~50m
- Accuracy: +/-3cm
- Horizontal field of view:300°
- Range Frequency:20KHZ
- Scan Frequency:10HZ~30HZ
- Horizontal angular resolution:0.18°(10HZ) ~0.54°(30HZ)
- Environment light resistance:>80000LX
- Power Supply:5V/500mA
- Power Consumption:<2.5w
- Dimensions:50mm * 50mm * 75mm
- Product Net Weight:150g
- IP Level: IP65
- Interface: micro-USB
- Operation Temperature: -10°C~55°C
- Storage Temperature: -30°C~75°C

Model Catalog

Chart 1

Model Number	VP300A	VP300B	VP300C	VP300E	VP300F
Range distance (Max.)	15m	25m	35m	45m	55m

Setup Instruction

Lidar is a precision photoelectric sensor device. Please keep the outer surface of the infrared cover clean during installation to avoid contamination and scratches, so as not to block the field of view or generate invalid data noise.

The laser emission and reception area of the VP300 in the vertical direction is shown in Figure 1. When installing, please refer to the area marked by the diagonal line in Figure 1, and reserve at least 5 mm of vertical open space above and below to ensure that the laser emission and reception are not blocked.

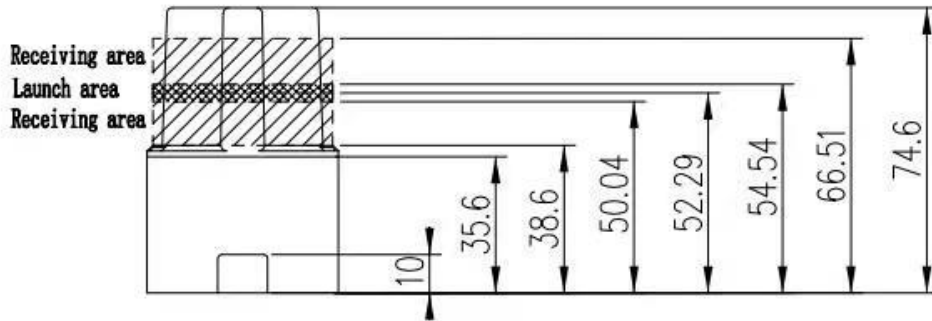

Fig.1 Laser Emission Area

Installation

VP300 has threaded mounting holes at the bottom of the shell, as shown in Figure 2:

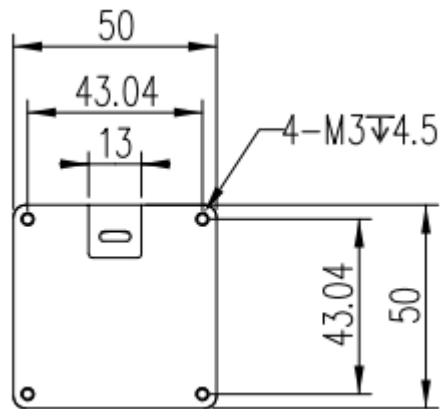

Fig. 2 Mounting holes

Electrical Interface

VP300 uses a single micro-USB interface for power supply and data interaction. The user can choose a normal micro-USB cable or a 90° bent micro-USB cable according to the installation requirements. If there are other types of interface requirements, we also provide various types of adapter boards that can be converted to UART, Ethernet, RS232/485, and IO ports adapted to PLC.

Use Manual

Prep Before Use

In normal case, after connecting the USB, the computer will display a virtual serial port, as shown in the figure below:

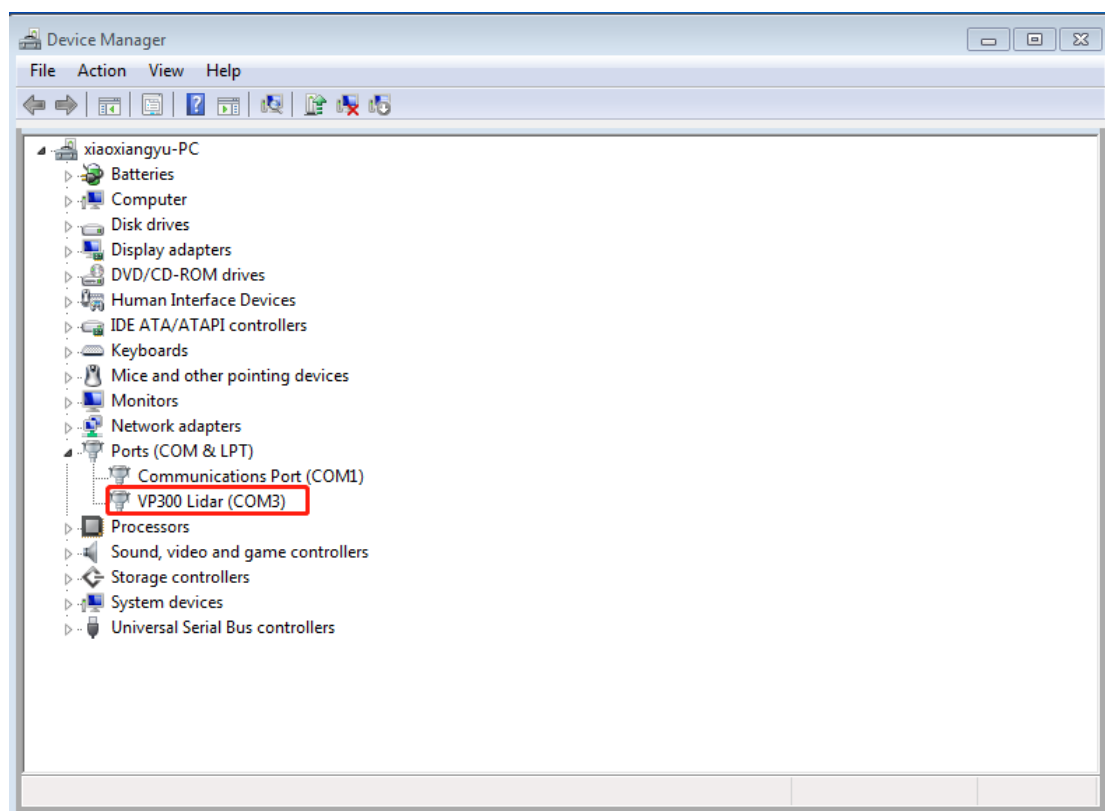

If the serial device cannot be recognized normally, you need to install the driver. The driver download address is:

https://www.arterytek.com/download/VirtualCOM_DriverInstall_CH_V

[1.0.30.zip](#)

If the serial device shown in the figure above can be recognized normally, the preparation work can be completed.

Software instruction

Open the lidarviewer.exe software, you can see the following interface:

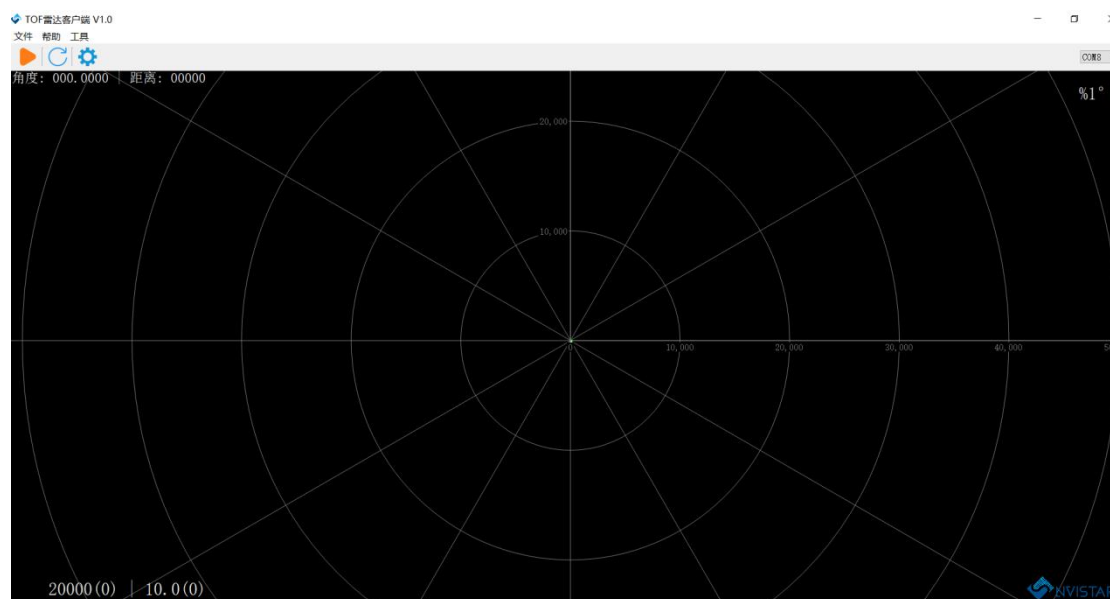

Start/Stop the Lidar



Refresh serial port



Configuration/Setting

The setting table is shown below, you can set the sampling rate, scan frequency, intensity signal, and invalid data filter level function according to actual applications.

Config

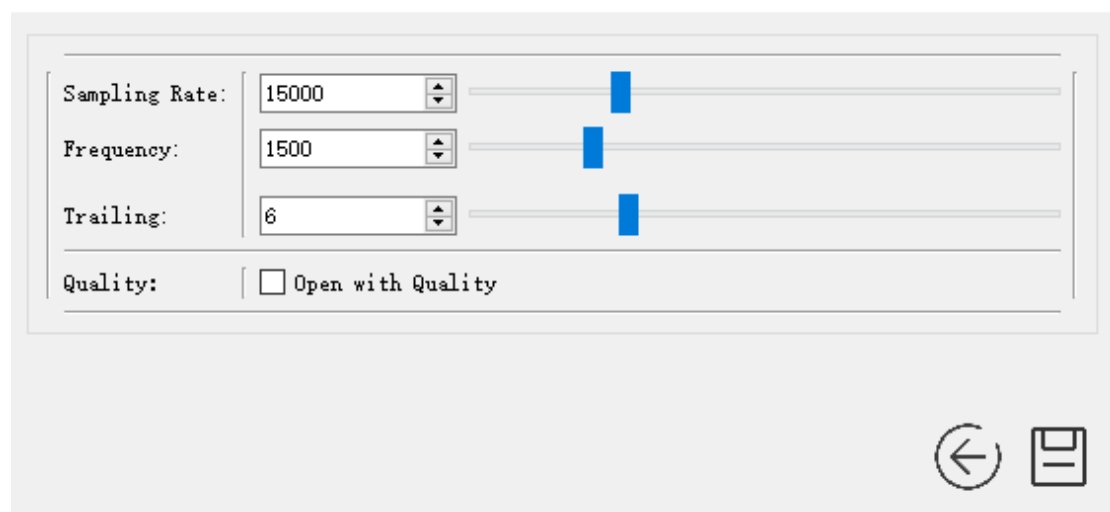

Start Lidar

Click  to start the Lidar and start to output data.

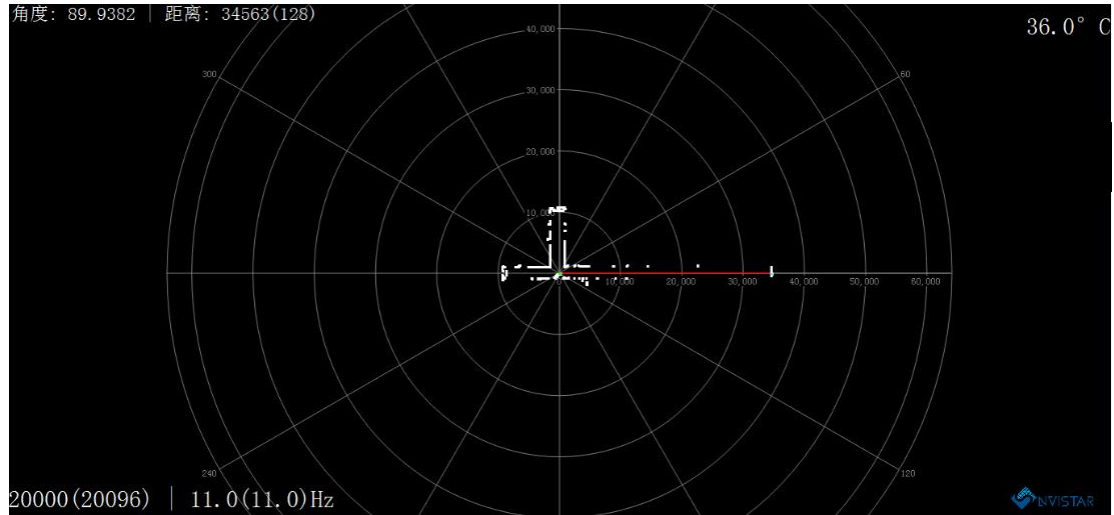

As shown in the figure above, 20000 (20096) in the lower left corner is the target sampling rate of 20K and the actual speed of 20.096K. 11.0 (11.0) means the target speed is 11Hz, and the actual speed is 11Hz. The upper right corner is the Lidar real-time temperature.

 TOF Viewer V1.0.2 =====> Lidar Name:VP300 Software Version:V1.4 Hardware Version:V1.0 SerialNumber:0000000000000000

Top banner shows the Lidar Mode, Hardware Version No., Software No. and Serial No..

Sizes and Dimensions

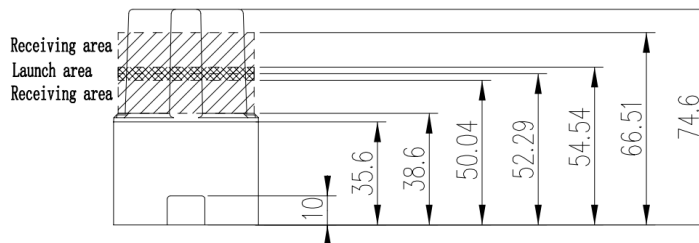
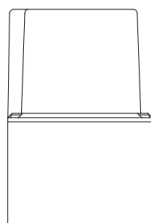
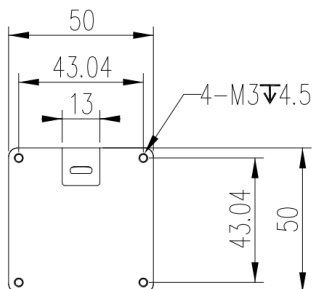

Appendix Revision History

Date	Version	Content
2021-7-26	1.0	First draft