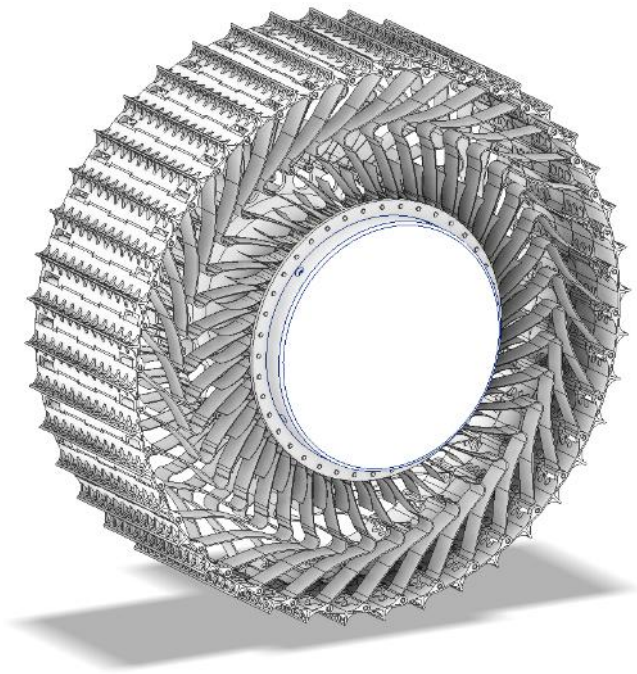

HTR

Hellenic Technology of Robotics

Hub-less Lunar Wheel User Manual

Technical Document

User Manual



Version: v11.0

30/10/2025



TABLE OF CONTENTS

1	Overview	5
1.1	Document Presentation	5
2	The Hub-less HTR Lunar Flexible Wheel.....	7
2.1	Hub-less Wheel Characteristics	7
2.2	Materials	9
2.3	Specifications.....	9
2.4	Photo Gallery	10
2.5	Plans.....	13
3	Endurance and Wear	15
4	Maintenance and Safety	16
4.1	Routine Maintenance	16
5	Typical Application Scenaria: Interfacing the Wheel with your Rover	17
6	Frequently Asked Questions.....	20
6.1	Related Videos	25



TABLE OF FIGURES

Figure 1-1: The hub-less wheel with protective front cover (as shipped).....	5
Figure 1-2: Hub-less wheel with mounting flange (from where motion is transmitted), as shipped (hole dimensions as on plans below, chapter 4).	6
Figure 2-1: CCW wheel (left) and CW wheel (right) as shipped. The preferential direction of motion is shown with an arrow on the wheel cover.	8
Figure 2-2: Comparative traction performance graph for HTR wheels (dotted line, reaching 0.4 drawbar / axis load at 20% slip ratio), compared to NASA Ti NI Wheels (blue line, reaching 0.25 drawbar / axis load at 40% slip ratio) and MSL rigid wheels (red line, reaching 0.18 drawbar/axis load at 70% slip ratio).	8
Figure 2-3: HTR wheel tests in ASTROBOTIC test facilities (GRC-1).	9
Figure 2-4: Wheel general view from vehicle side.	Error! Bookmark not defined.
Figure 2-5: Hub-less wheel exhibiting deformation when climbing a stone.	11
Figure 2-6: Hub-less wheel exhibiting deformation when climbing a stone.	11
Figure 2-7: Hub-less wheel under 710N static load exhibiting full deformation.	12
Figure 2-8: Hub-less plan side and track.	13
Figure 2-9: Hub-less wheel track and Section B-B in scale 1/2.	14
Figure 3-1: Wheel test setup and test results.	15
Figure 5-1: Wheel mounting interface front view.	17
Figure 5-2: Wheel mounting interface side view.	17
Figure 5-3: Wheel motor mounting interface.	18
Figure 5-4: Wheel mounting interface cut view.	18
Figure 5-5: Example of powering the wheel through an axis coming out of a rover chassis.	19
Figure 5-6: Example of powering the wheel though an axis, with the motor located inside the chassis of the rover.	19
Figure 6-1: Wheel: CW rotation.	20
Figure 6-2: Wheel: CCW rotation.	20
Figure 6-3: Rim segment/ Spring axle screw removal.	21
Figure 6-4: Spring hub-screw removal.	22
Figure 6-5: Rim segment removal.	22
Figure 6-6: Assembly overview of Hub-less wheel, HTR motorized hub and HTR rover.	24
Figure 6-7: The HTR rover chassis with 4 wheels mounted.	25



LIST OF TABLES

Table 2-1: Hubless HTR Lunar wheel main characteristics. 10

Document change record.

Version	Date	Description	Affected sections
1.0	13/05/2025	First Draft	All
2.0	15/05/2025	First Draft	Chapter 2
3.0	19/05/2025	Advanced Draft	Chapter2 and 3
4.0	21/05/2025	Advanced Draft	Chapter 3
5.0	25/05/2025	Advanced Draft	Chapter 4 and 5
6.0	29/05/2025	Advanced Draft	All
7.0	01/06/2025	Advanced Draft	Formatting text
8.0	02/06/2025	Final Draft	All figures
9.0	03/06/2025	Final Draft	Chapter 3 added
10.0	03/06/2025	Final Draft	Update captions and added references
11.0	30/10/2025	Final Draft	Update specifications



The HTR hub-less lunar wheel without front cover.

1 OVERVIEW

1.1 Document Presentation

This document is structured as follows:

- Chapter 1 presents the document.
- Chapter 2 provides information about the wheel.
- Chapter 3 provides information about the endurance and wear on the wheel.
- Chapter 4 provides maintenance advice.
- Chapter 5 provides typical application scenarios: Interfacing the Wheel with your Rover.
- Chapter 6 gives a list of FAQ.



Figure 1-1: The HTR hub-less lunar wheel with protective front cover (as shipped).

Hellenic Technology of Robotics

v11.0

User Manual

Page 5 of 26

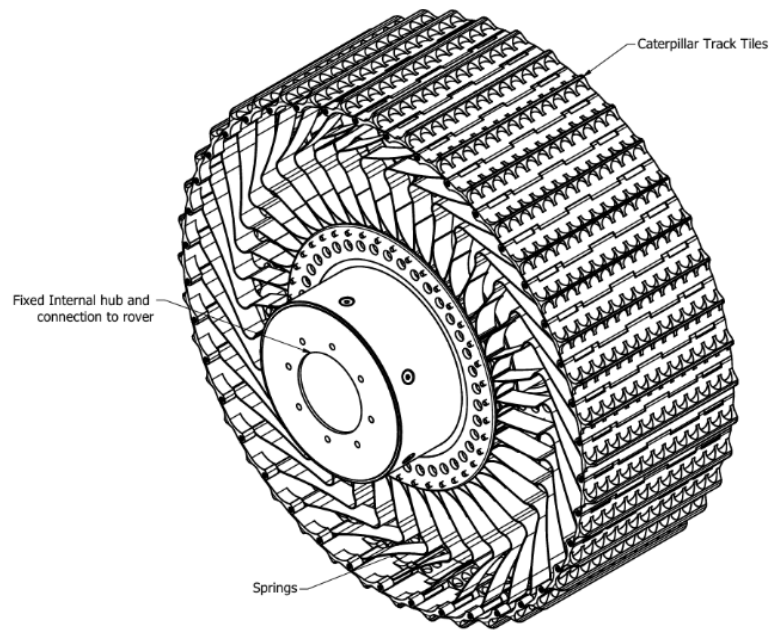

Figure 1-2: Hub-less wheel with mounting flange (from where motion is transmitted), as shipped (interface hole dimensions as on plans below, chapter 5).



2 THE HUB-LESS HTR LUNAR FLEXIBLE WHEEL

In this chapter the main properties and characteristics of the HTR hub-less lunar wheel are presented.

2.1 Hub-less Lunar Wheel Characteristics

The wheel is the closest equivalent of a flight wheel that can survive the lunar environment. Operating your rover with these wheels will give you the closest possible behaviour of your machine on a lunar landscape. The performance of the wheel is astonishing, even when compared with rubber tires. The wheel actually behaves like a caterpillar, embracing terrain irregularities and absorbing shocks. The resulting operation is extremely smooth, as it can also be seen on videos (list at the end of the document).

The wheel comes in 2 spring stiffness options: 06 and 08.

Both 06 and 08 wheels also automatically vary their stiffness during operation: The stiffness increases when the wheel generates higher torque, in connection with the ground. That is, the harder the soil, the higher the stiffness the wheel can reach (within a predefined range). This further increases the adaptability and efficiency of the wheel.

The 06 wheel is designed to carry a smaller load (150 N) compared to the 08 type of wheel, that can carry a 250 N load. The 06 wheel is more suitable for very loose (GRC-1) type of soils, while the 08 wheel is designed for soils bearing higher ground pressures.

The wheels have a preferential direction of motion. This is due to the automatic stiffness adaptation, which will operate correctly if the wheel is operated along its preferential direction of motion. We recommend to apply this direction as the forward direction of motion of your rover. Therefore, for use on a 4 wheel rover, you must use 2 wheels with clockwise preferential direction of motion and 2 wheels with counter-clockwise preferential direction of motion. The preferential direction of motion is shown on each wheel cover (figure below).



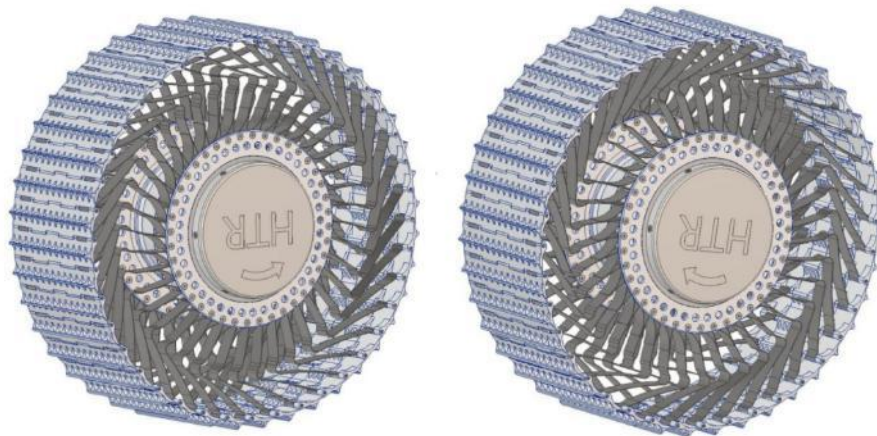

Figure 2-1: CCW wheel (left) and CW wheel (right) as shipped. The preferential direction of motion is shown with an arrow on the wheel cover.

The wheels exhibit exceptional traction on loose soils, surpassing the performance of rigid wheels and also the NASA Ti Ni wheels. Comparative graphs below demonstrate the difference:

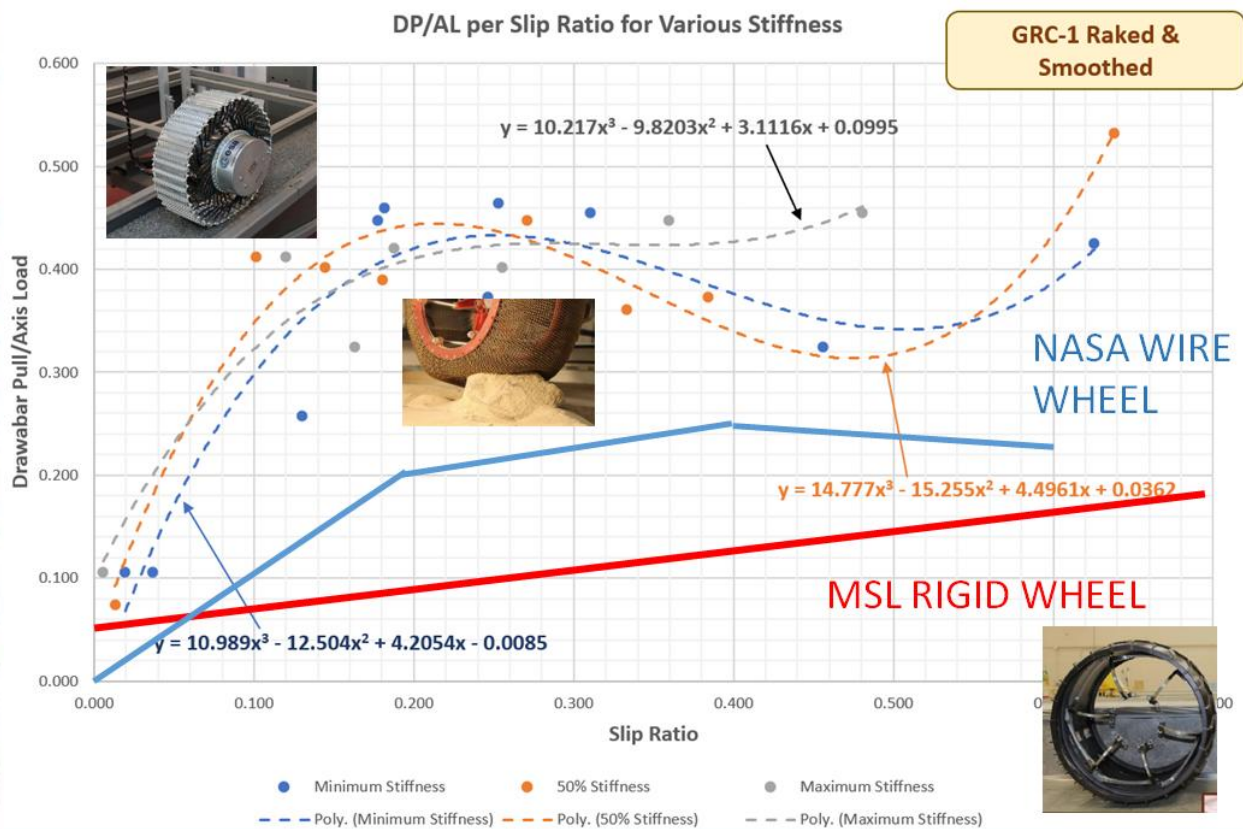

Figure 2-2: Comparative traction performance graph for HTR wheels (dotted line, reaching 0.4 drawbar / axis load at 20% slip ratio), compared to NASA Ti Ni Wheels (blue line, reaching 0.25 drawbar / axis load at 40% slip ratio) and JPL MSL rigid wheels (red line, reaching 0.18 drawbar/axis load at 70% slip ratio).

All the above test results refer to GRC-1 lunar analogue soil.

All HTR wheel tests of the above graph have been performed on GRC-1, as HTR has carried out such tests in ASTROBOTIC test facilities on 2021.

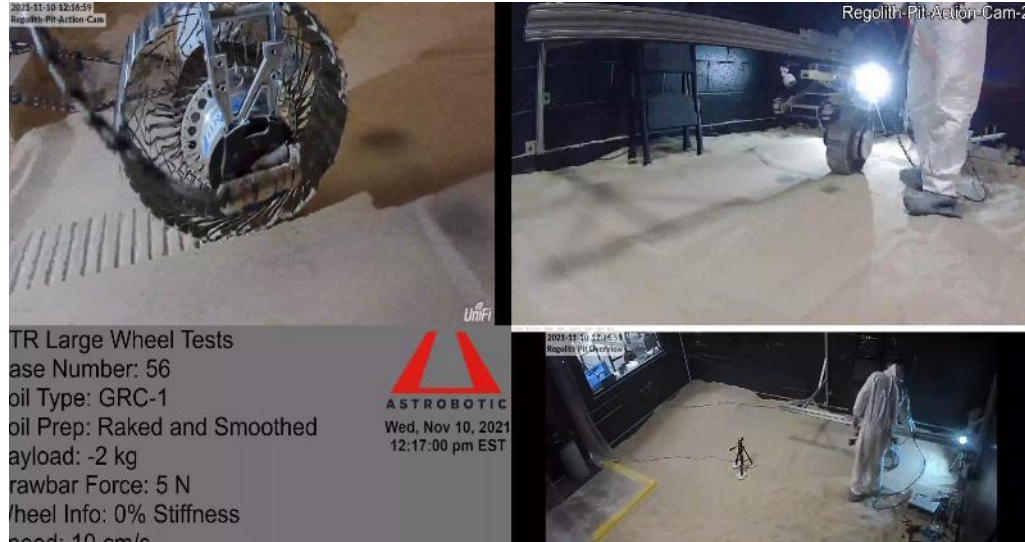

Figure 2-3: HTR wheel tests in ASTROBOTIC test facilities (GRC-1).

2.2 Materials

The wheels are built entirely from cryo-resistant, corrosion resistant materials. As such they could be used in extremely low temperatures (minus 180°C), or high temperatures (plus 150°C), without performance degradation. Although the wheels sold have not passed flight qualification tests, they are built in exactly the same way as the wheels that are flight qualified. However, adhesives used are not flight qualified.

2.3 Specifications

Specifications		
Parameter	Value/Description	
Wheel	Diameter	360 mm
	Tile Width	130 mm
	Overall Width including hubs	184 mm
	Radial Stiffness	Variable, 2500N/m to 10000N/m (measured as hub displacement)

Specifications

Mass	3.8 kg
Max speed	15 Km/h
Max torque on wheel axis	70 Nm
Max load per wheel (operational) for 06 type	150N
Max load per wheel (operational) for 08 type	250N
Max load per wheel (static) for 06 type	700N
Max load per wheel (static) for 08 type	800N

Table 2-1: HTR hub-less Wheel main characteristics.

Caution:

Operating the 06 type of wheels for extended periods at loads exceeding 150N may gradually damage the springs leading to spring failures. In the same way, operating the 08 wheels for extended periods with loads exceeding 250 N may also shorten the life time of the springs. Such damages may not show up immediately, but over several thousands of cycles.

- How to order the wheels:

The hub-less wheel needs to be ordered according to the 4 options as follows:

HUBLESS WHEEL 06 CLOCKWISE OPERATION

HUBLESS WHEEL 06 COUNTER CLOCKWISE OPERATION

HUBLESS WHEEL 08 CLOCKWISE OPERATION

HUBLESS WHEEL 08 COUNTER CLOCKWISE OPERATION

2.4 Photo Gallery





Figure 2-4: Hub-less wheel exhibiting deformation when climbing a stone.



Figure 2-5: Hub-less wheel exhibiting deformation when climbing a stone.





Figure 2-6: Hub-less wheel under 710N static load exhibiting full deformation.

2.5 Plans

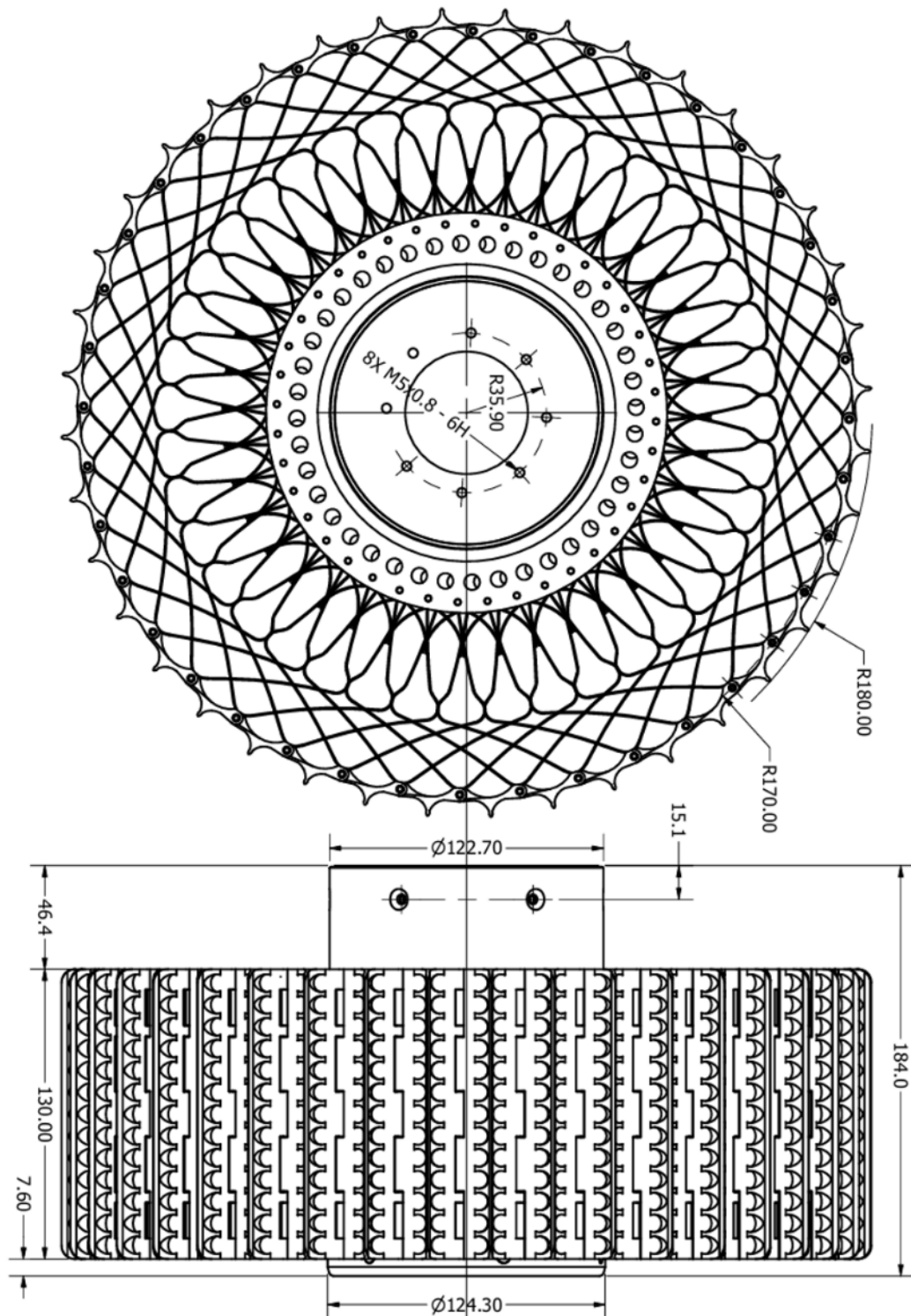

Figure 2-7: Hub-less plan side and track.

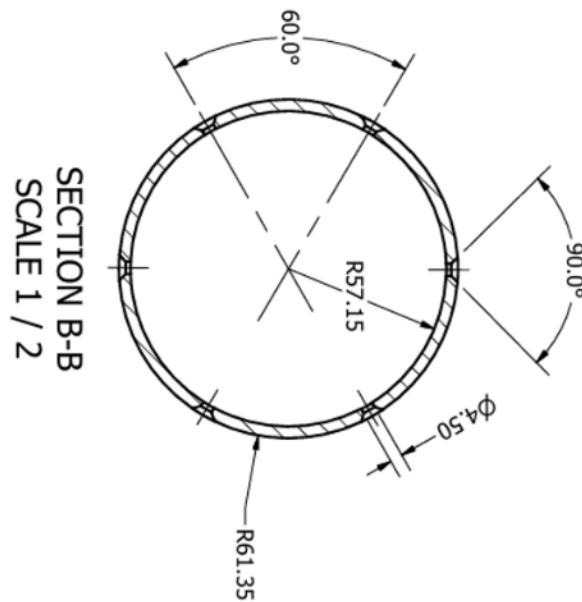
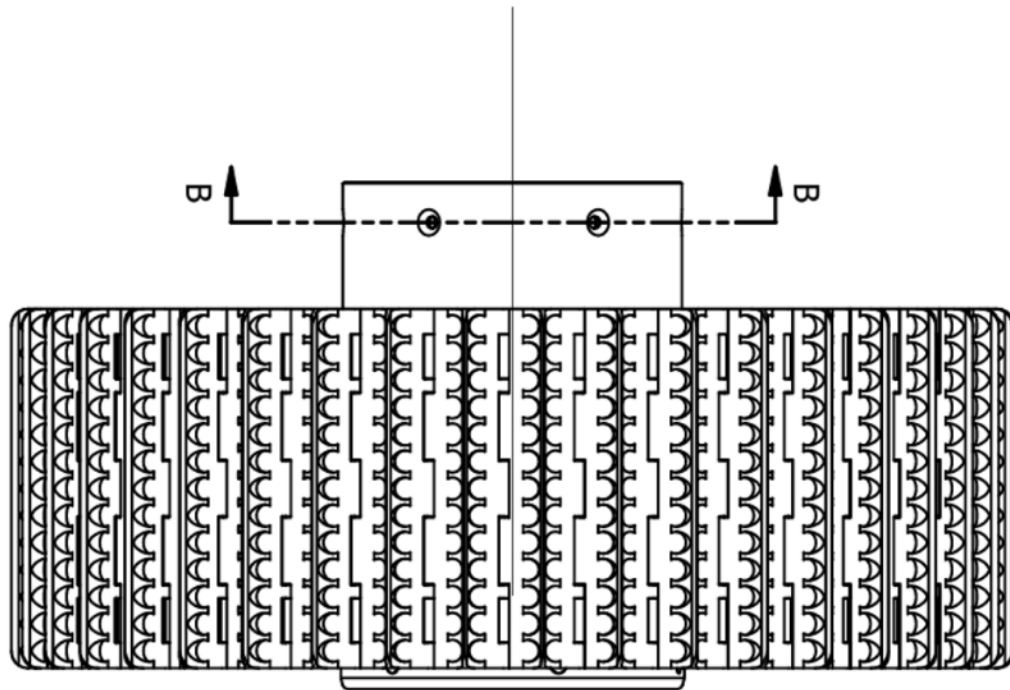

Figure 2-8: Hub-less wheel track and Section B-B in scale 1/2.

4 MAINTENANCE AND SAFETY

4.1 Routine Maintenance

- **Check wheel free deformation:**

The wheels should be checked for free deformation, in order to detect items that may hinder this functionality. It is extremely rare that small stones are trapped between the springs and the tiles. When this occurs, the stones are usually removed naturally from the wheel rotation.

- **Clean moving parts:**

If mud, branches or other vegetation elements have clogged the space between the tiles and the springs, you will notice the wheel becoming stiffer, as there is no room for deformation. As the wheels are designed for operation on a surface without mud or vegetation, this contamination needs to be removed.

5 TYPICAL APPLICATION SCENARIO: INTERFACING THE WHEEL WITH YOUR ROVER

You can easily interface the HTR wheel with a moving flange coming from your rover. The following plans show the interfacing details:

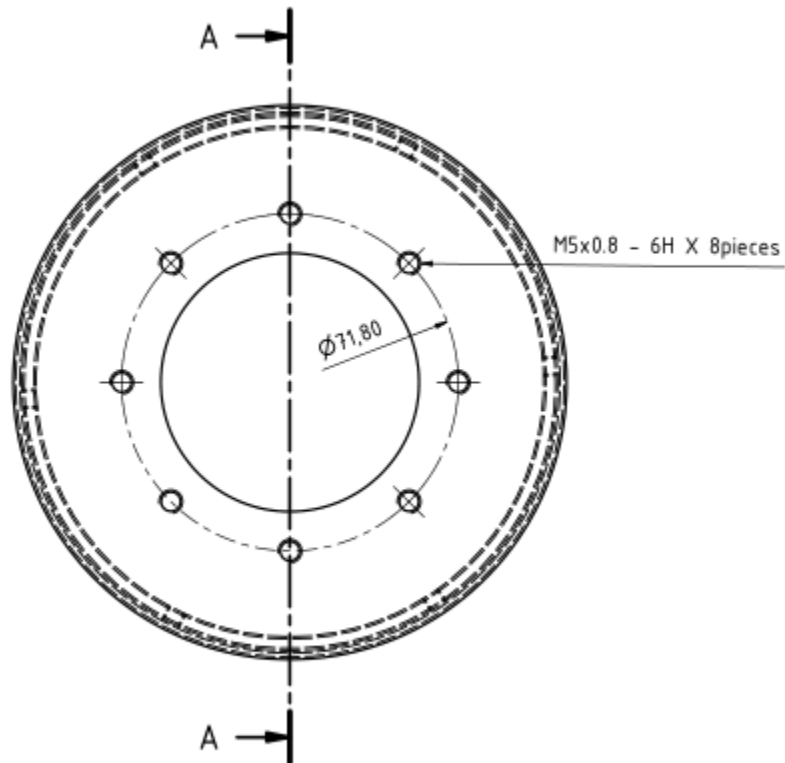

Figure 5-1: Wheel mounting flange front view.



Figure 5-2: Wheel mounting flange side view.

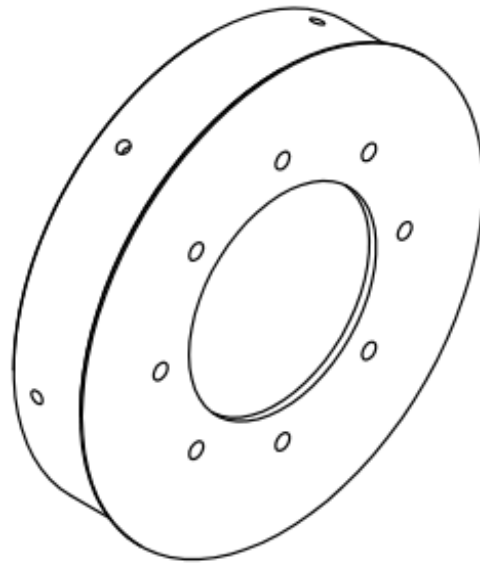

Figure 5-3: Wheel mounting interface side view.

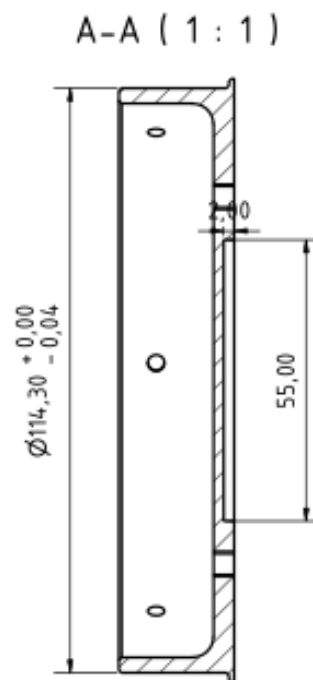

Figure 5-4: Wheel mounting interface cut view.

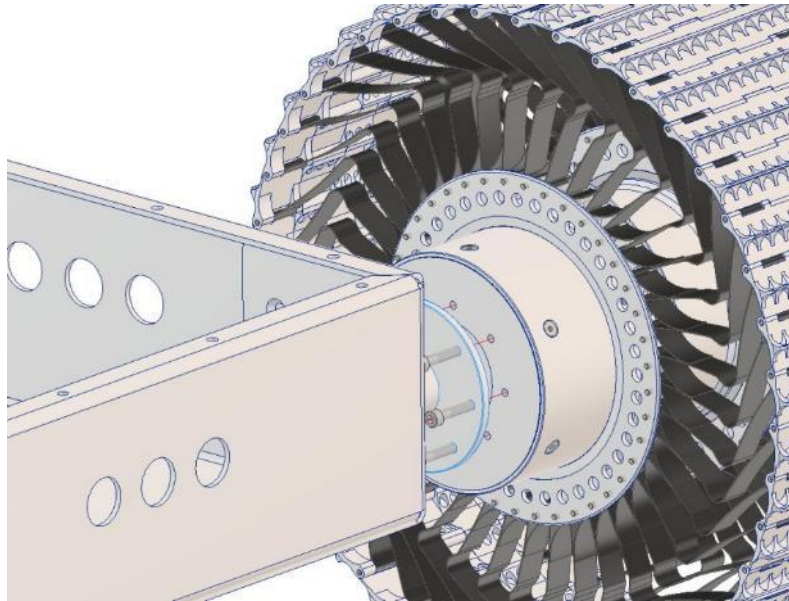

Figure 5-5: Example of powering the wheel through an axis coming out of a rover chassis.

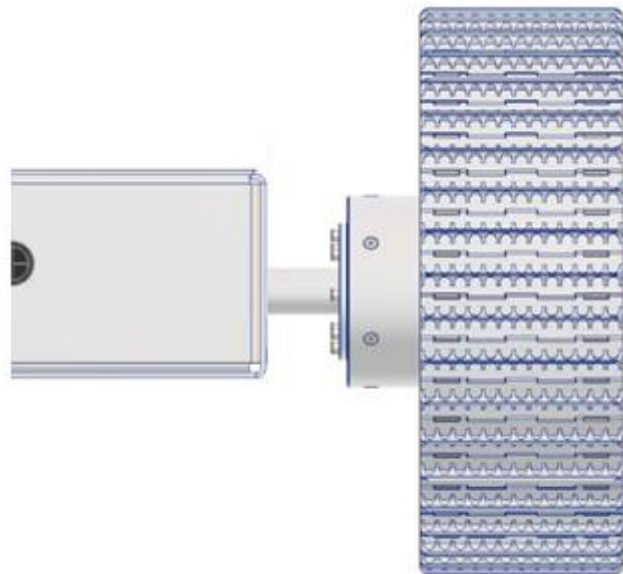

Figure 5-6: Example of powering the wheel through an axis, with the motor located inside the chassis of the rover.

In a similar way, the wheel can be powered through an axis with the motor located in a suspension arm, a bogie etc.

6 FREQUENTLY ASKED QUESTIONS

1. Q: Does the wheel have a preferred sense of rotation?

A: Yes. The stiffness mechanism varies in behaviour depending on the orientation of the springs and the rotation of the wheel. Below see images of the spring orientation and rotation correlation:

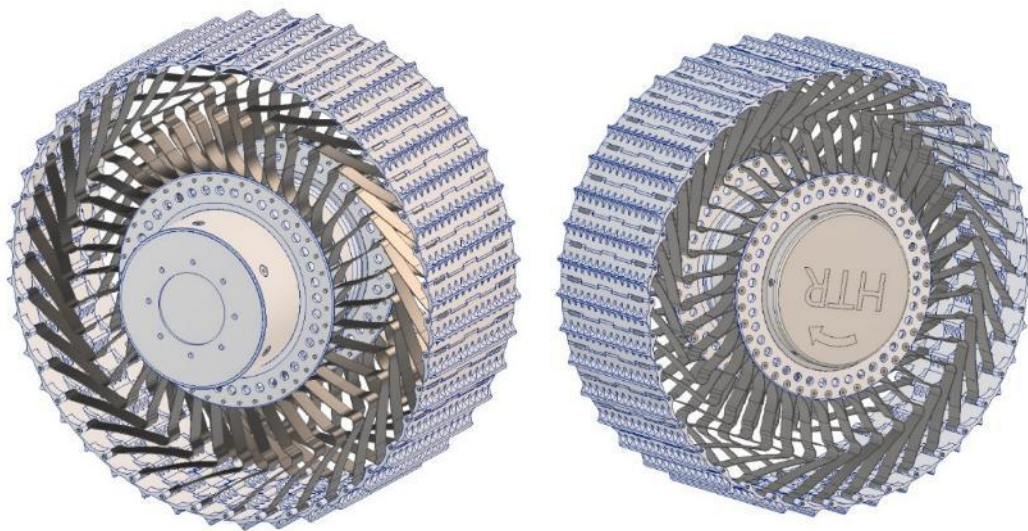

Figure 6-1: Wheel: CW rotation.

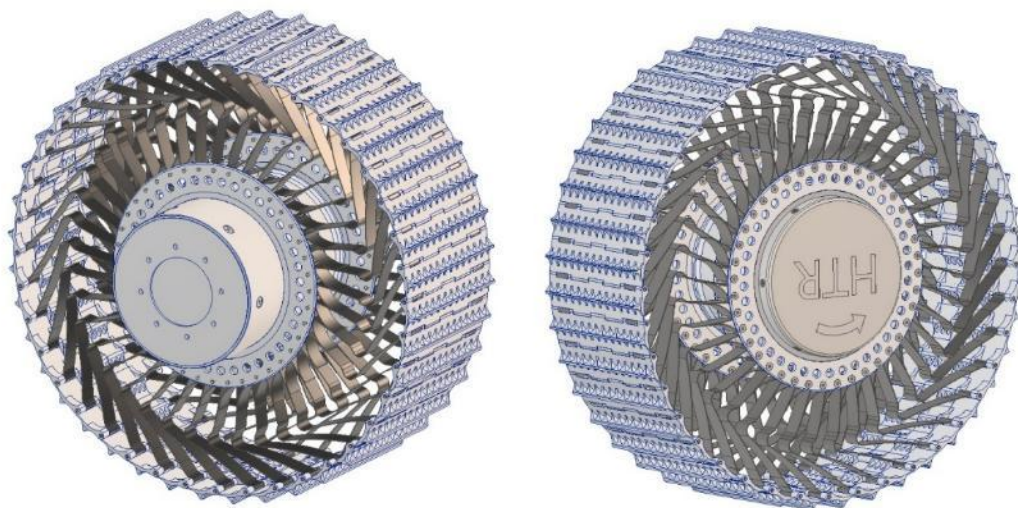

Figure 6-2: Wheel: CCW rotation.

2. Q: Is the hub-less HTR wheel flight qualified?

A: No. The hub-less HTR wheels have not gone through space qualification testing, as this would substantially increase their cost. However, the wheels we sell have a very similar design to the wheels that are qualified for flight.

3. Q: How stiffness variation affects performance of the wheel?

A: Stiffness variation alters the amount of surface pressure from the wheels rim to the ground below. This affects many aspects of the performance, namely:

- It increases efficiency, as energy is not wasted in local hysteresis deformations but rather fully utilized.
- It prevents slippage, again making conservation of energy easier.
- With greater surface contact, the max drawbar pull of the wheel is increased.

4. Q: What happens in case of collision?

A: Collisions are bound to happen. The wheel functions as a suspension to the system in general. If the collision is more violent than expected, some springs may get damaged around the area of collision.

5. Q: Can I repair a broken spring without sending the wheel back to HTR?

A: Yes, replacing a spring is possible without sending the wheel back but attention must be given when trying to remove the bolts, as we use adhesive to prevent them from becoming loose.

- Remove the top securing headless screws on both sides of the rim.

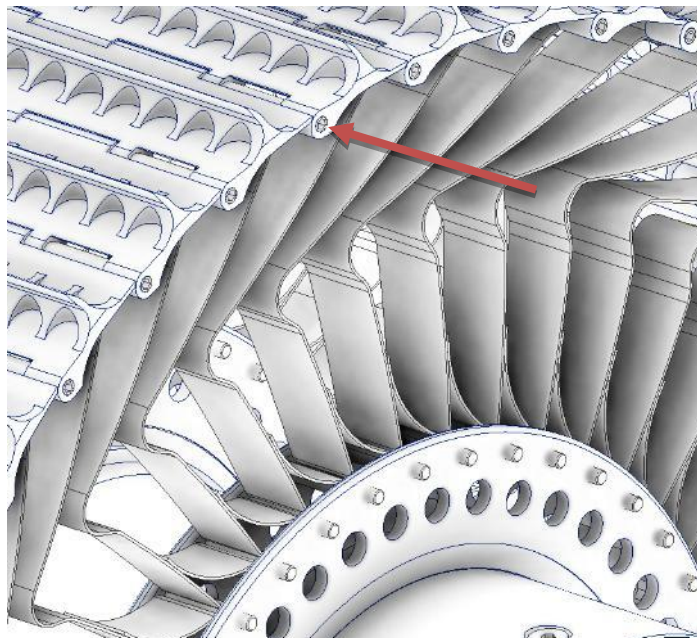

Figure 6-3: Rim segment/ Spring axle screw removal.

- By using a 3mm diameter axle, push the rim axle out, removing it from the spring that has been damaged. Be careful not to completely remove the rim axle, only push it out of the spring to be removed.
- -Undo the screw that holds the damaged spring on the internal rim.

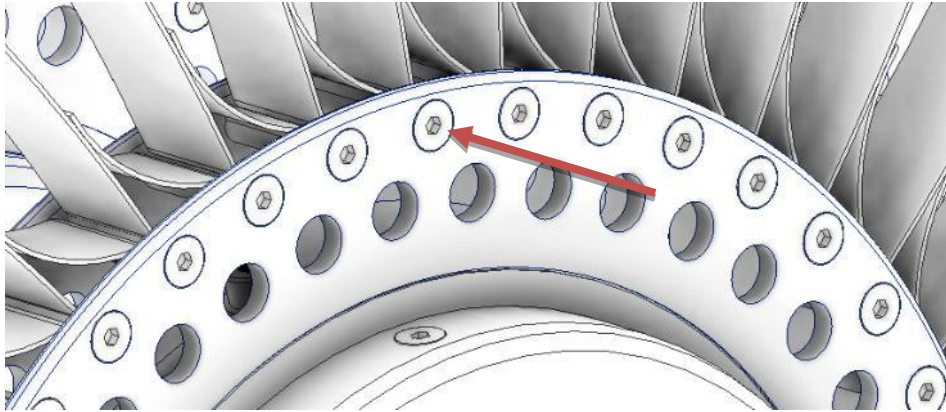

Figure 6-4: Spring hub-screw removal.

- Remove the now released damaged spring and replace it with the new one.
- Fasten the internal screw and pass the external rim axle through the spring.
- Re-apply the top headless screws.

Note: All screws should get dried adhesive removed and re-applied upon fastening.

6. Does HTR sell single springs separately as replacing parts?

Yes. A spring can be sold separately with a cost of around 20 Euros, plus postage and taxes.

7. Q: Can I repair a damaged rim segment (tile) without sending the wheel back to HTR?

A: Yes, you can repair a damaged rim segment by following the instructions below.

- Remove the axle securing headless screws on either side of both axles holding the rim segment in place.

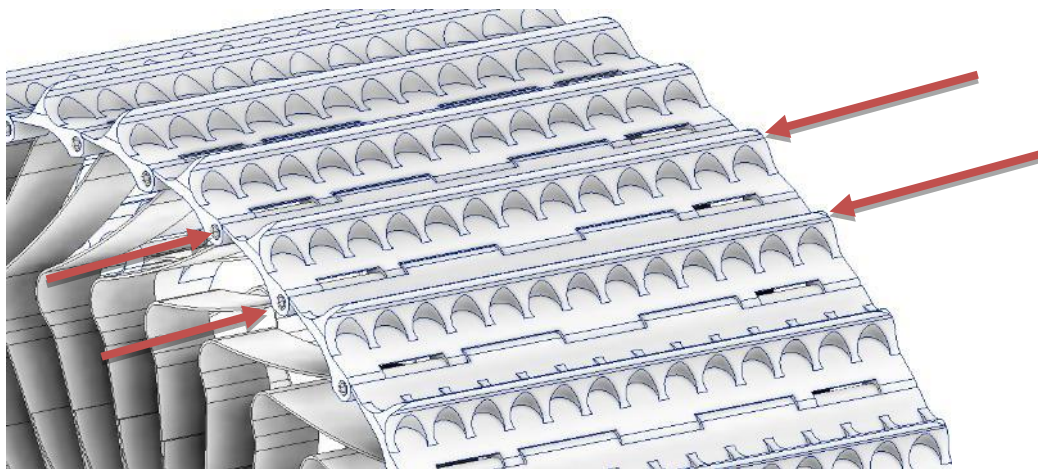

Figure 6-5: Rim segment removal.



Once the screws are removed, carefully push the two axles out of position using a 3mm rod, completely removing them.

- Remove the, now free, damaged rim segment and place the new segment in position.
- Carefully push the two axles through, making sure to pass it through all four released springs and the adjacent rim segments.
- Fasten the four headless securing screws.

Note: All screws should get dried adhesive removed and re-applied upon fastening.

8. [Q: Can I purchase spare parts?](#)

A: Yes. If the spare part is not listed on the re-seller website, contact HTR directly at sales@htr.gr

9. [Q: For what distance and under which conditions the wheel has been tested?](#)

A: The wheel has been tested for a distance of 1000km at a speed of 4-7 km/h on regolithic soil with heavy regolithic sand contamination during the operation.

10. [Q: How wear affects wheel performance?](#)

A: Material wear on the rim segments does not significantly affect the wheel's performance. Broken springs at low numbers (<15 broken springs, not consecutive) do not significantly alter performance either.

11. [Q: What guarantee is offered by HTR?](#)

A: We guarantee that under nominal conditions the wheel is able to traverse 250km without the need for hardware replacement.

12. [Q: Are hub-less HTR Lunar wheels compatible with HTR wheels having in-hub motors?](#)

A: Yes, the designs are the same. If you have bought the hub-less version of the HTR wheel, we offer upgrade packages to install the HTR motorized hub.

13. [Q: Can I convert a hub-less HTR wheel into a wheel having an HTR in-hub motor?](#)

14. A: Yes, you may integrate an HTR motorized hub within the hub-less wheel, below find a diagram of the assembly principle.

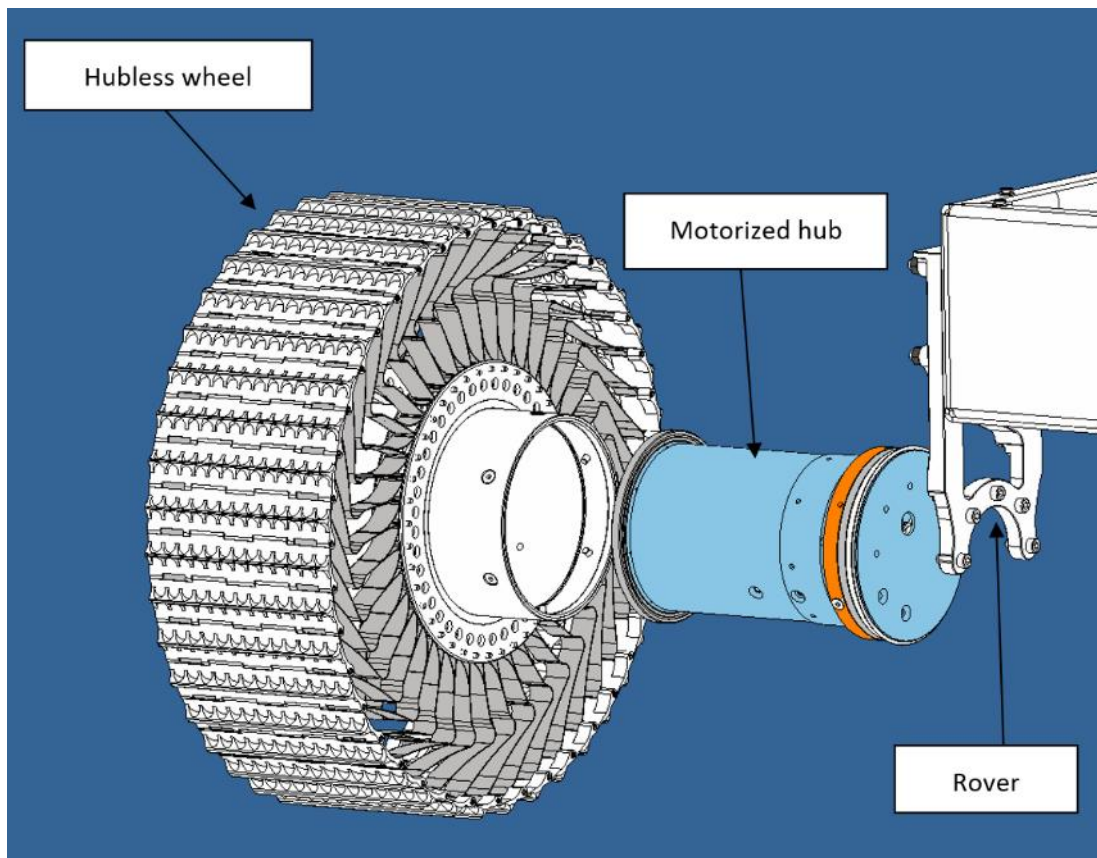

Figure 6-6: Assembly overview of Hub-less wheel, HTR motorized hub and HTR rover.

- The assembly is easy, so a motorized hub can be purchased at a later instance and integrated in the hub-less wheel, in case you decide to use HTR in-hub motorization.

HTR's in-hub motorization is an extremely rugged tailored made gearbox with motor, that guarantees operation under the harshest conditions. HTR's rover and associated wheel drive electronics, guarantee smooth operation and optimal traction in the most demanding conditions.

15. Q: What are the specifications of HTR's in-hub motor solutions?

A: The in-hub motorization is compatible with all hub-less wheel models. For Hub Motor specifications, please refer to the Hub Motor wheel manual or write us to sales@htr.gr.

16. Q: How much an in-hub motor solution for HTR wheel would cost?

Please refer to the Hub Motor wheel product for details or write us to sales@htr.gr

17. Q: Does HTR offer motor controllers for the in-hub motor wheels?

A: HTR does not offer single controllers for the standalone in-hub motor wheel, but we do offer a 4-wheel controller with a rover chassis designed to carry 4 wheels. Please refer to the HTR rover chassis manual or write us to sales@htr.gr.

18. Q: How much a rover chassis with 4 motor controllers and a master would cost?

A: Please refer to the HTR rover chassis product for details or write us to sales@htr.gr.



Figure 6-7: The HTR rover chassis with 4 wheels mounted.

6.1 Related Videos

Single HTR lunar wheel under compression.

Single HTR lunar wheel on stones

Single HTR lunar wheel on regolith.

HTR lunar Wheel mounted on heavy rover on stones

HTR Lunar rover chassis with 4 wheels on GRC-1 similar sand

HTR Lunar rover chassis with 4 wheels escalating rocks

To see these videos, please visit:

In <https://www.linkedin.com/company/hellenic-technology-of-robotics/posts/?feedView=all>

References:

Hellenic Technology of Robotics

User Manual

v11.0

Page 25 of 26

1. <https://www.semanticscholar.org/paper/Energetics-impact-from-the-use-of-flexible-and-on-Papantoniou-Skevakis/bb9cffd549bf2d733db60c9dbfb33ce842ac39e1>
2. <https://www.hou.usra.edu/meetings/isairas2020fullpapers/pdf/5079.pdf>
3. <https://patents.google.com/patent/EP3808573B1/en?q=EP3808573B1>
4. <https://patents.google.com/patent/US11623472B2/en?q=US11623472B2>

END OF DOCUMENT

