

# TG50 DATA SHEET



# CONTENTS

<b>1</b>	<b>PRODUCT OVERVIEW</b> .....	<b>1</b>
1.1	Product Features .....	1
1.2	Applications .....	1
1.3	Installation and Dimensions .....	2
<b>2</b>	<b>SPECIFICATIONS</b> .....	<b>2</b>
2.1	Product Parameter.....	2
2.2	Range Accuracy.....	3
2.3	Electrical Parameter .....	3
2.4	Interface Definition .....	3
2.5	Data Communication .....	4
2.6	Motor Control.....	5
2.7	Optical Characteristic.....	5
2.8	Polar Coordinate System Definition .....	5
2.9	Others.....	6
<b>3</b>	<b>DEVELOPMENT AND SUPPORT</b> .....	<b>6</b>
<b>4</b>	<b>REVISE</b> .....	<b>8</b>

# 1 PRODUCT OVERVIEW

YDLIDAR TG50 is a 360° 2D LiDAR(hereinafter referred to as TG50) developed by YDLIDAR team. Based on the principle of ToF, it is equipped with related optics, electricity, and algorithm design to achieve high-frequency and high-precision distance measurement. The mechanical structure rotates 360° to continuously obtain the angle information and output the point cloud data of the scanning environment while ranging.

## 1.1 Product Features

- IP65 protection level
- 360° omnidirectional scanning and 5-12Hz frequency
- Ranging frequency up to 20kHz
- High accuracy, stable performance
- Strong resistance to ambient light interference
- Class I eye safety

## 1.2 Applications

- Robot navigation and obstacle avoidance
- Industrial automation
- Regional security
- Smart transportation
- Environmental scanning and 3D reconstruction
- Digital multimedia interaction
- Robot ROS teaching and research

## 1.3 Installation and Dimensions

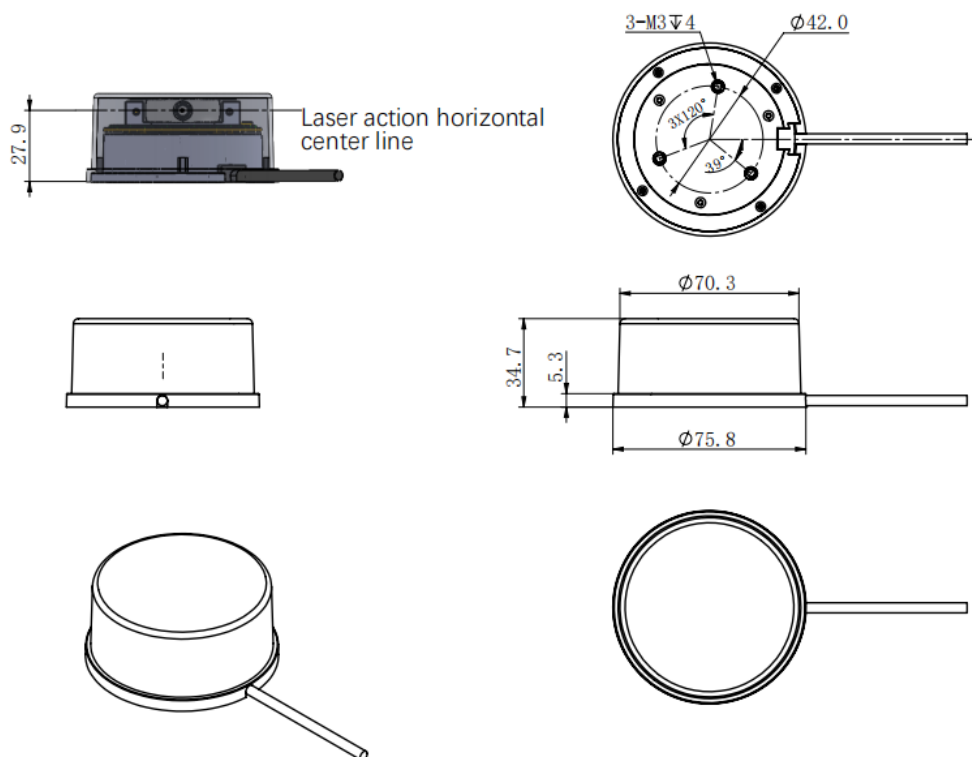

FIG 1 YDLIDAR TG50 INSTALLATION & MECHANICAL SIZE

## 2 SPECIFICATIONS

### 2.1 Product Parameter

CHART 1 YDLIDAR TG50 PRODUCT PARAMETER

Item	Min	Typical	Max	Unit	Remarks
Ranging frequency	/	20000	/	Hz	/
Motor frequency	5	7	12	Hz	Software control, factory setting 7Hz
Ranging distance	0.05	/	50	m	80% reflectivity
Field of view	/	0-360	/	Deg	/
Angle resolution	0.09 (Frequency @5Hz)	0.13 (Frequency @7Hz)	0.22 (Frequency @12Hz)	Deg	Ranging frequency=20kHz
Laser level	0	/	1	Deg	/

## 2.2 Range Accuracy

**CHART 2 YDLIDAR TG50 RANGE ACCURACY**

Distance (mm)	Mean error (mm)
50-5000	$\leq \pm 60$
5000-20000	$\leq \pm 40$
20000-30000	$\leq \pm 100$
30000-50000	$\leq \pm 150$

## 2.3 Electrical Parameter

**CHART 3 YDLIDAR TG50 ELECTRICAL PARAMETER**

Item	Min	Typical	Max	Unit	Remarks
Supply voltage	4.8	5.0	5.2	V	Excessive voltage might damage the Lidar while low affect normal performance
Startup current	/	840	1000	mA	Instantaneous peak current at start-up
Working current	/	340	480	mA	System works, motor rotation
Sleeping current	/	/	50	mA	System sleeps, motor stops

Note: 5V 1A power supply device.

## 2.4 Interface Definition

TG50 provides PH2.0-5P female connector to realize power and data communication function.

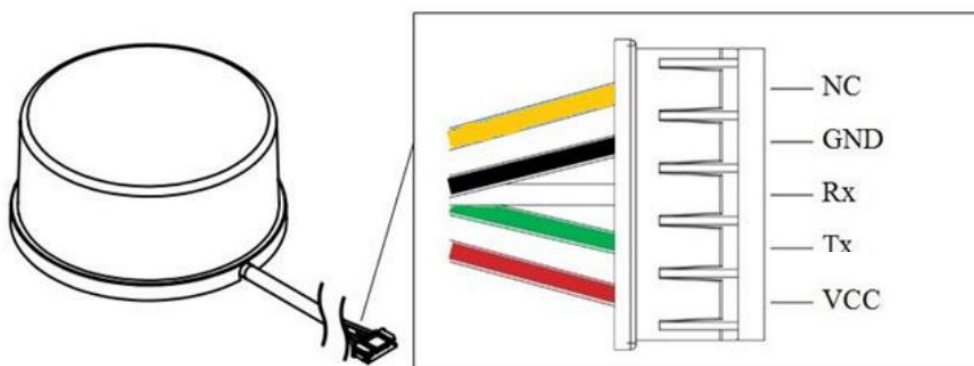

FIG 2 YDLIDAR TG50 INTERFACES

**CHART 4 YDLIDAR TG50 INTERFACE DEFINITION**

Pin	Type	Description	Defaults	Range	Remarks
VCC	Power Supply	Positive	5V	4.8V-5.2V	/
Tx	Output	System serial output	/	/	Data stream: Lidar→Peripherals
Rx	Input	System serial port Input	/	/	Data stream: Peripherals→Lidar
GND	Power Supply	Negative	0V	0V	/
NC	Reserve	Reserved pin	/	/	/

The product is equipped with Type-C USB transfer module to realize Type-C USB connection.

Type-C USB: data communication and power supply.

Micro USB: Only power supply.

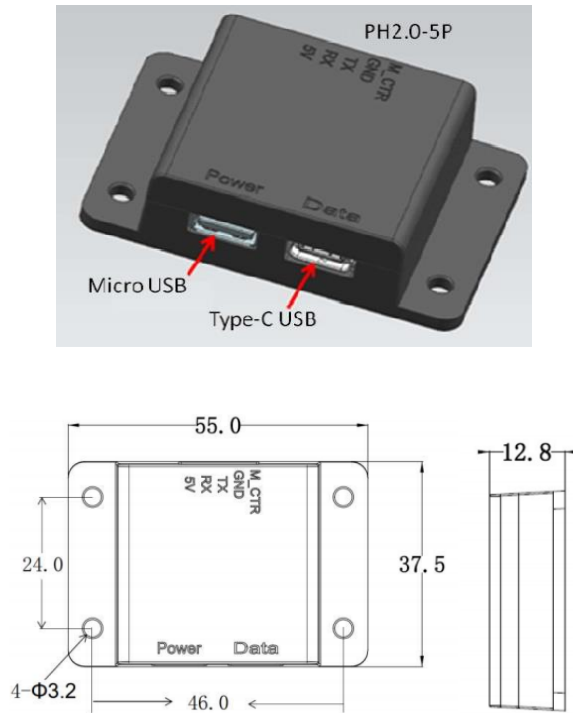

FIG 3 YDLIDAR TG50 POLAR COORDINATE SYSTEM DEFINITION

**2.5 Data Communication**

With a 3.3V level serial port (UART), users can connect the external system and the product through the physical interface. After that, you can obtain the real-time scannedpoint

cloud data, device information, device status and device working mode can be set etc. The communication protocol of parameters are as follows:

**CHART 5 YDLIDAR TG50 SERIAL SPECIFICATION**

Item	Min	Typical	Max	Unit	Remarks
Baud rate	/	512000	/	bps	8-bit data bit,1 stop bit, no parity
High Signal Level	2.4	3.3	3.5	V	Signal voltage>2.0V
Low signal Level	0	0.3	0.6	V	Signal voltage<0.8V

## 2.6 Motor Control

The TG50 has its own motor drive with motor speed control function and a command interface instead of a hardware interface for motor control. Please refer to the development manual of this product for details.

## 2.7 Optical Characteristic

TG50 uses an infrared laser that meets FDA Class I eye safety standards. The laser and optical lens finish the transmission and reception of the laser signal to achieve high-frequency ranging while working. The detailed optical parameters are as follows:

**CHART 6 YDLIDAR TG50 LASER OPTICAL PARAMETERS**

Item	Min	Typical	Max	Unit	Remarks
Laser Wavelength	895	905	915	nm	Infrared band
Laser Power	/	1.5	/	mW	/
FDA	 Class I				

## 2.8 Polar Coordinate System Definition

In order to facilitate secondary development, TG50 internally defines a polar coordinate system. The polar coordinates of the system take the center of the rotating core of TG50 as the pole, and the specified Angle is positive clockwise (top view). The zero Angle is located in the direction of the outlet of the TG50 interface line, as shown in the figure:

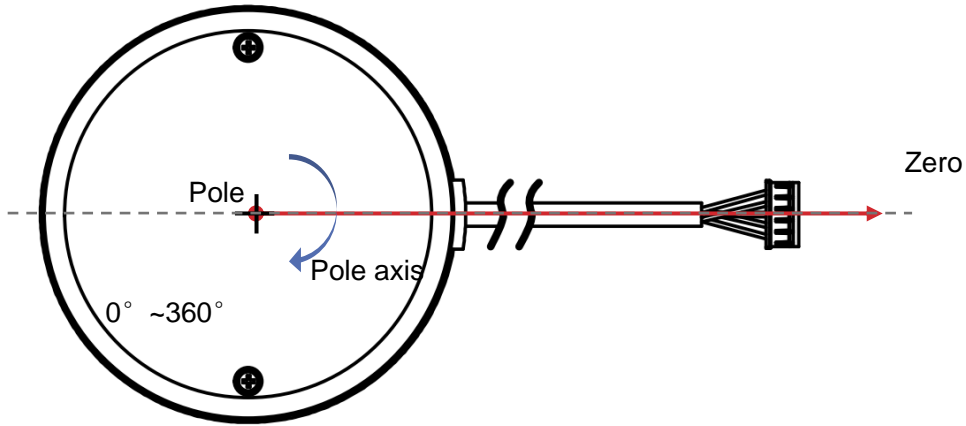

FIG 4 YDLIDAR TG50 POLAR COORDINATE SYSTEM DEFINITION

Note: When the Lidar is assembled on the machine, the deviation of the assembly may cause slight difference in the consistency of the zero position. For the convenience of use, we provide a zero calibration software, which can customize the zero direction and assemble to the machine. The lidar is calibrated twice. For details, please refer to the instruction manual.

## 2.9 Others

CHART 7 YDLIDAR TG50 OTHERS

Item	Min	Typical	Max	Unit	Remarks
Operating temperature	0	25	50	°C	/
Storage temperature	-10	/	60	°C	/
Lighting environment	0	70000	100000	Lux	For reference only, the laser transceiver cannot be directly towards the strong light source such as the sun
weight	/	140	/	g	N.W.

## 3 DEVELOPMENT AND SUPPORT

TG50 provides a wealth of software interfaces, which can realize the motor enabling control, speed control, range unit enabling control and output control of the system. On this basis, users can also implement the power control and scan control purpose.



Also, the 3D model of TG50 is disclosed. YDLIDAR provides the graphics debugging Workstation under Windows, as well as the corresponding SDK and ROS development kit to users, which could be downloaded from our website: <https://www.ydlidar.com/>.

In order to facilitate users' development, TG50 development manual, SDK development manual and ROS user manual are also provided. Please download them from [our website](#).

## 4 REVISE

Date	Version	Content
2019-05-26	1.0	Compose a first draft
2020-09-02	2.0	Update the interface connector diagram to change the connector to a bayonet
2021-06-10	3.0	Electrical parameters, laser parameters, performance parameters comprehensive update
2021-07-08	3.1	Inserted the segmented ranging accuracy of section 2.2