

# **YDLIDAR X2 DATASHEET**

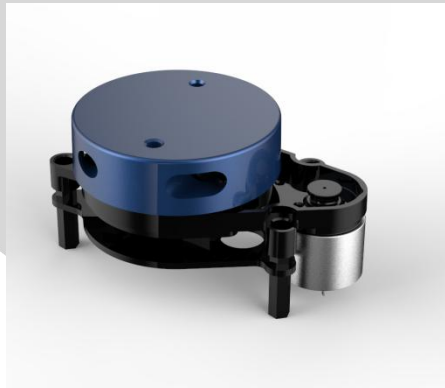

Doc#: 01.13.000100



<https://www.facebook.com/ydlidar/>

## Contents

Overview.....	2
Product Features.....	2
Applications.....	2
Installation and dimensions.....	2
Specifications.....	3
Product parameter.....	3
Chart 1 YDLIDAR X2 Product Parameter.....	3
Electrical parameter.....	4
Chart 2 YDLIDAR X2 Electrical Parameter.....	4
Interface definition.....	4
Chart3 YDLIDAR X2 Interface Definition.....	5
Data communication.....	5
Chart4 YDLIDAR X2 Serial Specification.....	5
Motor control.....	5
Chart5 YDLIDAR X2 Motor PWM signal Specification.....	5
Optical characteristic.....	6
Chart 6 YDLIDAR X2 Laser Optical Parameters.....	6
Polar coordinate system definition.....	6
Others.....	7
Chart7 YDLIDAR X2 Others.....	7
Development and support.....	7
Revision.....	8

## OVERVIEW

---

The YDLIDAR X2 Lidar is a 360-degree two-dimensional distance measurement product (hereinafter referred to as X2) developed by the YDLIDAR team. This product is based on the principle of triangulation, and is equipped with relevant optics, electricity, and algorithm design to realize high-frequency and high-precision distance measurement. At the same time as the distance measurement, 360 degrees of scanning distance measurement is achieved by continuously obtaining the angle information through the 360 degree rotation of the motor.

### Product Features

- 360-degree scanning distance measurement
- Small distance error; stable distance measurement and high accuracy
- Wide ranging range, not less than 8m
- Strong resistance to ambient light interference
- Low power consumption, small size, stable performance and long life
- Laser power meets Class I laser safety standards
- Ranging frequency up to 3000hz (Support customization)

### Applications

- Robot navigation and obstacle avoidance
- Robot ROS teaching and research
- Regional security
- Environmental Scan and 3D Reconstruction
- Home service robot/robot vacuum cleaner navigation and obstacle avoidance

### Installation and dimensions

Laser launch receiving center

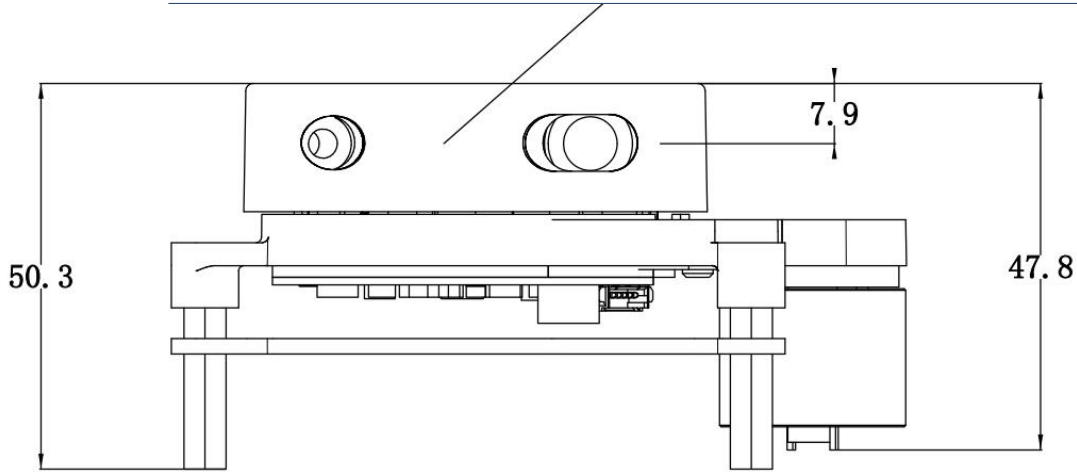

FIG1 YDLIDAR X2FRONT STRUCTURAL SIZE

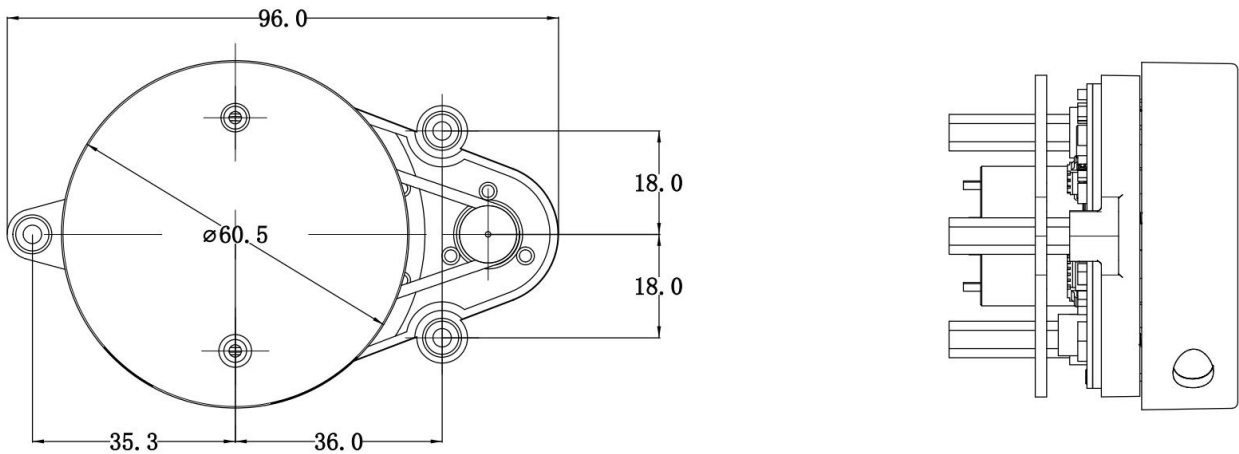

FIG2 YDLIDAR X2 MECHANICAL DIMENSIONS

## SPECIFICATIONS

### Product parameter

Chart 1 YDLIDAR X2 Product Parameter

Item	Min.	Typical	Max.	Unit	Remarks
Range frequency	-	3000	-	Hz	3000 times/s
Scan frequency	5	-	8	Hz	PWM or Voltage regulation
Distance Range	0.10	-	>8	m	Indoor
Scanning	-	0~360	-	Deg	-

angle				
Relative error	-	2.0%	-	-

Note 1: The relevant parameters of the relative error are the factory settings.

Note 2: The relative error value characterizes the accuracy of the Lidar measurement,

$$\text{relative error} = (\text{measuring distance} - \text{actual distance}) / \text{actual distance} * 100\%$$

As a precision equipment, Lidar needs to be protected during use. In high-temperature, high-low temperature or strong vibration use scenarios, the relative error parameter index may reach 3%.

## Electrical parameter

Chart 2 YDLIDAR X2 Electrical Parameter

Item	Min.	Typical	Max.	Unit	Remarks
Supply voltage	4.8	5	5.2	V	Excessive voltage might damage the device while low affect normal performance
Voltage ripple	0	50	100	mV	Excessive ripple affect normal performance
Starting current	300	400	500	mA	Higher current required at start-up
Working current	200	350	380	mA	Normal working

## Interface definition

X2 provides a PH1.25-4P female connector with functional interfaces for system power, data communication and motor control.

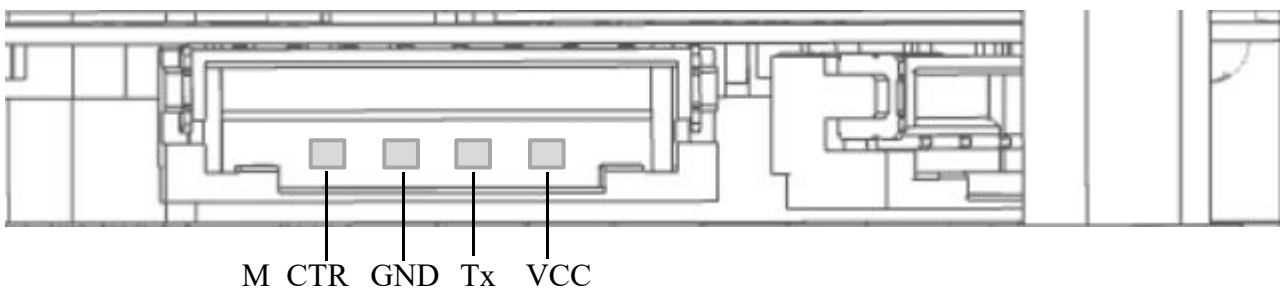

FIG3 YDLIDAR X2 INTERFACES

**Chart3 YDLIDAR X2 Interface Definition**

Pin	Type	Description	Defaults	Range	Remarks
VCC	Power supply	Positive	5V	4.8V~5.2V	-
Tx	Output	System serial output	-	-	Data stream: Lidar --> peripherals
GND	Power supply	Negative	0V	0V	-
M_CTR	Input	Motor speed control terminal	1.8V	0V~3.3V	Voltage regulation or PWM speed regulation

**Data communication**

The X2 uses a 3.3V level serial port (UART) for communication. Users can connect the external system and the product through the physical interface and obtain the real-time scanned point cloud data, device information as well as device status according to the communication protocol of the system. Besides, X2 also supports setting the device working mode. The communication parameters are as follows:

**Chart4 YDLIDAR X2 Serial Specification**

Item	Min.	Typical	Max.	Unit.	Remarks
Baud rate	-	115200	-	bps	8-bit data bit, 1 stop bit, no parity
Signal high	1.8	3.3	3.5	V	signal voltage >1.8V
Signal low	0	0	0.5	V	signal voltage <0.5V

**Motor control**

The X2 has its own motor driver with motor speed control function. The peripheral can control the X2 motor by inputting the control signal through the M\_SCTP pin in the interface. M\_SCTP is the motor speed control signal, which can be adjusted by voltage or PWM wave. The lower the voltage / the smaller the PWM duty cycle, the higher the motor speed.

The maximum speed is 0V/duty cycle 0%. That means when the M\_SCTP input 0V voltage, the motor rotates at the highest speed.

Following are the PWM signal requirements of M\_SCTP :

**Chart5 YDLIDAR X2 Motor PWM signal Specification**

Item	Min.	Typical	Max.	Unit.	Remarks
PWM	-	10	-	KHz	PWM is a square

frequency				wave signal
Duty cycle range	50%	85%	100%	The smaller the duty cycle, the faster the speed

**Optical characteristic**

The X2 uses an infrared point pulsed laser that meets FDA Class I laser safety standards. The laser and optical lens complete the transmission and reception of the laser signal to achieve high-frequency ranging at works. To ensure system ranging performance, please keep the laser and optical lens clean. The detailed optical parameters are as follows:

**Chart 6 YDLIDAR X2 Laser Optical Parameters**

Item	Min.	Typical	Max.	Unit.	Remarks
Laser wavelength	775	785	795	nm	Infrared band
Laser power	-	3	5	mW	Peak power
FDA	⚠ Class I				

**Polar coordinate system definition**

In order to facilitate secondary development, X2 internally defines a polar coordinate system.

Pole: the center of the rotating core of the X2;

Positive direction: clockwise;

Zero angle: directly in front of the X2 motor;

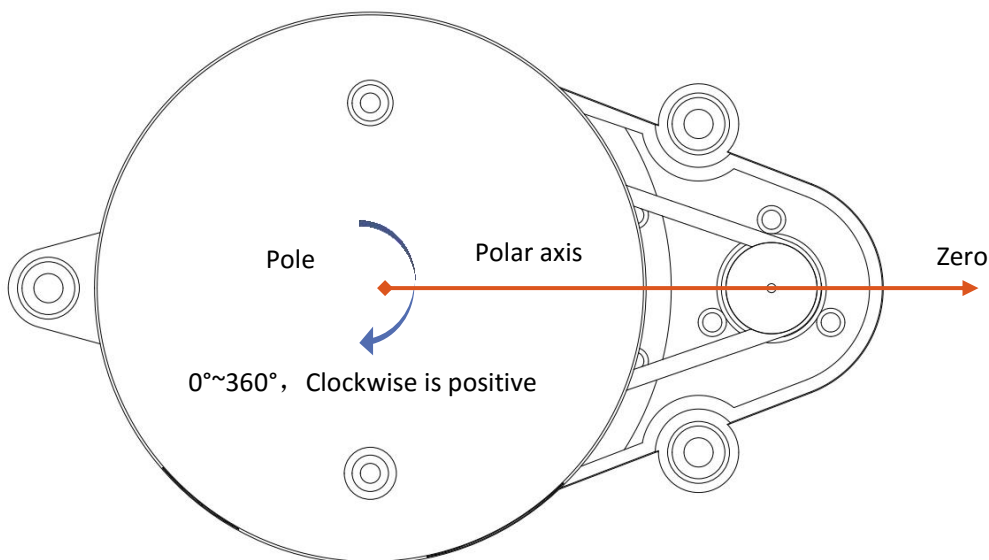

FIG4 YDLIDAR X2 POLAR COORDINATE DEFINITION

**Others**

**Chart7 YDLIDAR X2 Others**

Item	Min.	Typical	Max.	Unit.	Remarks
Operating temperature	0	20	50	°C	Long-term work in high temperature environment will reduce life expectancy
Lighting environment	0	550	2000	Lux	For reference only
N.W.	-	200	-	g	-

**DEVELOPMENT AND SUPPORT**

With a wealth of hardware and software interfaces,X2 can support motor enable control, speed control, and enable control&output control of the ranging core. Based on this, the user can also implement power control and scan control.

Users can also download the X2 development manual, SDK development manual and Ros manual on the official website: [www.ydlidar.com](http://www.ydlidar.com)

At the same time, the 3D model is open and the graphical debugging client under Windows, the corresponding SDK development kit and Ros development kit are also provided.



## REVISION

---

Date	Version	Contents
2019-04-24	1.0	First writing
2019-04-25	1.1	Modify the X2 interface definition