

YDLIDAR G4 DATASHEET

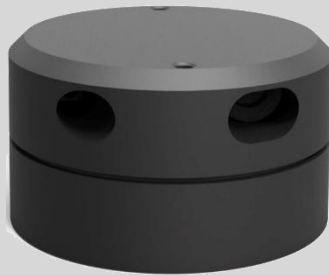

Contents

overview.....	2
Product Features.....	2
Applications.....	2
Installation and dimensions.....	2
Specifications.....	3
Product Parameter.....	3
Electrical Parameter.....	4
Interface Definition.....	4
Data communication.....	5
Motor control.....	6
Optical Characteristic.....	6
Polar coordinate system definition.....	6
Others.....	7
Development and support.....	7

OVERVIEW

YDLIDAR G4 is a 360-degree two-dimensional rangefinder (hereinafter referred to as G4) developed by YDLIDAR team. Based on the principle of triangulation, it is equipped with related optics, electricity, and algorithm design to achieve high-frequency and high-precision distance measurement. The mechanical structure rotates 360 degrees to continuously output the angle information as well as the point cloud data of the scanning environment while ranging.

Product Features

- 360 degree omnidirectional scanning ranging distance measurement
- Small distance error, stable performance and high accuracy
- Ranging distance is no less than 16m
- Strong resistance to ambient light interference
- Industrial grade brushless motor drive for stable performance
- Laser power meets Class I laser safety standards
- 5-12Hz adaptive scanning frequency (support customization)
- Ranging frequency up to 9kHz (support customization)

Applications

- Robot navigation and obstacle avoidance
- Robot ROS teaching and research
- Regional security
- Environmental scanning and 3D reconstruction
- Commercial robot /Robot vacuum cleaner

Installation and dimensions

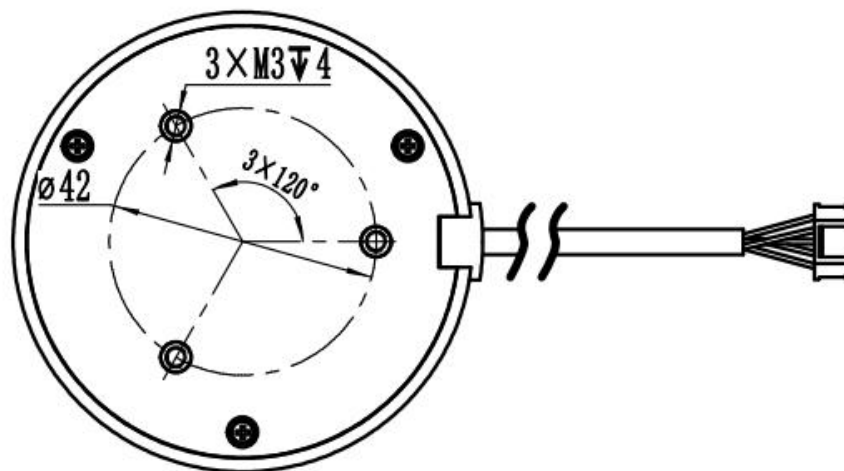

FIG1 YDLIDAR G4 INSTALLATION SIZE

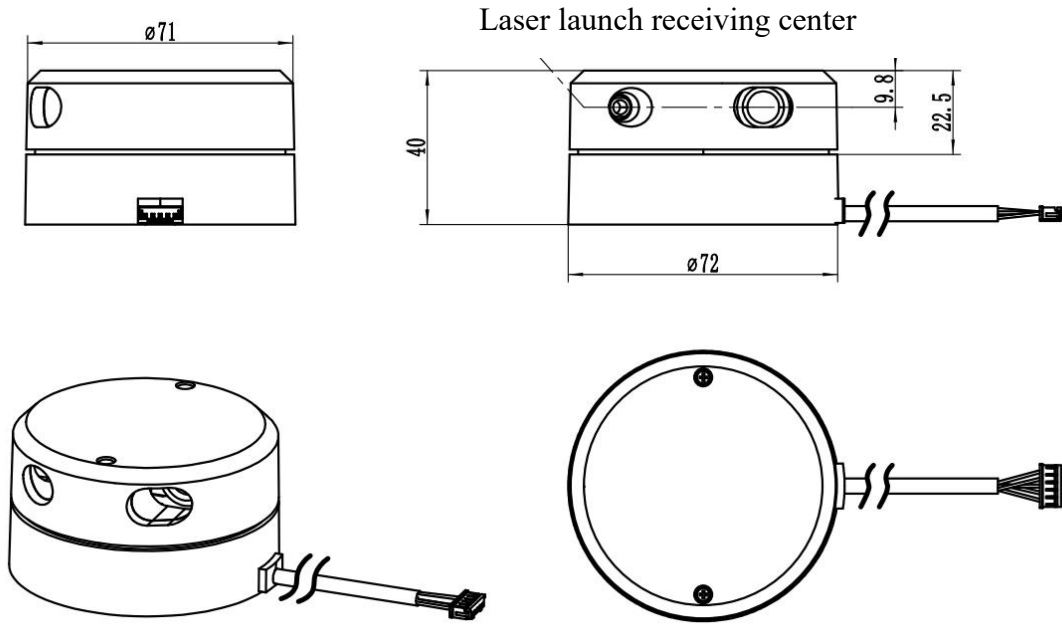

FIG2 YDLIDAR G4 MECHANICAL DIMENSIONS

SPECIFICATIONS

Product Parameter

CHART1 YDLIDAR G4 PRODUCT PARAMETER

Item	Min	Typical	Max	Unit	Remarks
Ranging frequency	4000	9000	9000	Hz	Support customization
Motor frequency	5	7	12	Hz	Software speed control, can be customized
Ranging distance	0.10	-	16	m	Motor frequency = 4KHz
	0.26	-	16	m	Motor frequency = 8KHz
	0.28	-	16	m	Motor frequency = 9KHz
Scanning angle	-	0~360	-	Deg	-

Absolute error	-	2	-	cm	Distance≤0.5m
Relative error	-	1.0%	-	-	0.5m<Distance≤6m
	-	1.5%	-	-	6m<Distance≤8m
Laser tilt	0.25	1	1.75	Deg	Laser elevation angle
Angle resolution	0.26	0.28	0.30	Deg	Scanning frequency=7

Note 1: The ranging range and relative accuracy above are the factory inspection standard value;

Note 2: The relative error value indicates the accuracy of the Lidar measurement.

Relative error = (Measuring distance - Actual distance) / Actual distance * 100%.

Please avoid using Lidar under high-temperature, high-low temperature or strong vibration use scenarios, which might cause a 3% relative error parameter index.

Electrical Parameter

CHART2 YDLIDAR G4 ELECTRICAL PARAMETER

Item	Min	Typical	Max	Unit	Remarks
Supply voltage	4.8	5.0	5.2	V	Excessive voltage might damage the Lidar while low affect normal performance
Voltage ripple	0	50	100	mV	Excessive ripple affect normal performance
Starting current	450	500	550	mA	Higher current required at start-up
Sleeping current	-	<50	-	mA	System sleep, motor rotation
Working current	400	450	480	mA	System work, motor rotation

Interface Definition

G4 provides a PH1.25-4P female connector with functional interfaces for system power, data communication and motor control.

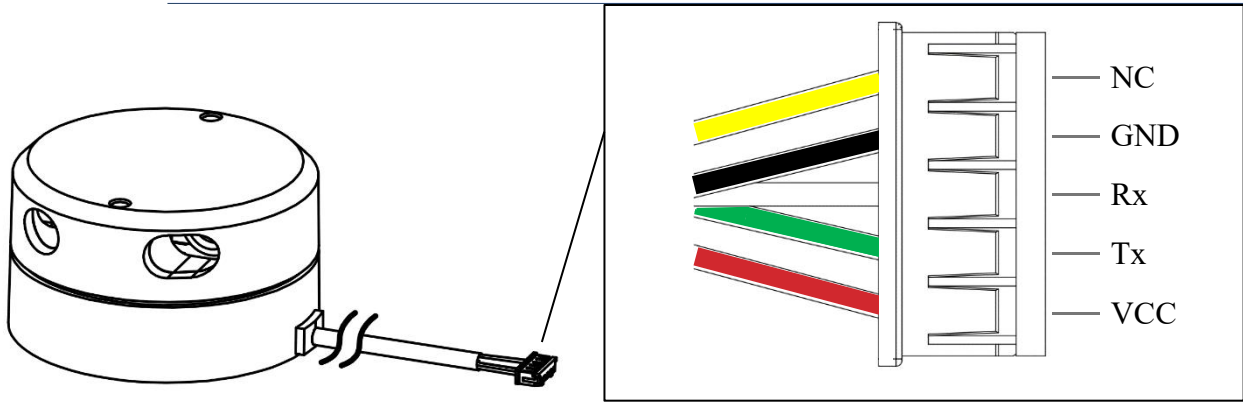

FIG3 YDLIDAR G4 INTERFACES

CHART3 YDLIDAR G4 INTERFACE DEFINITION

Pin	Type	Description	Defaults	Range	Remarks
VCC	Power Supply	Positive	5V	4.8V~5.2V	-
Tx	Output	System serial output	-	-	Data stream: Lidar→Peripherals
Rx	Input	System serial port Input	-	-	Data stream: Peripherals→Lidar
GND	Power Supply	Negative	0V	0V	-
NC	-	Reserved pin	-	-	-

Data communication

With a 3.3V level serial port (UART), users can connect the external system and the product through the physical interface. After that, you can obtain the real-time scanned point cloud data, device information as well as device status. The communication protocol of parameters are as follows: :

CHART4 YDLIDAR G4 SERIAL SPECIFICATION

Item	Min	Typical	Max	Unit	Remarks
Baud rate	-	230400	-	bps	8-bit data bit, 1 stop bit, no parity
High Signal Level	1.8	3.3	3.4	V	Signal voltage > 1.8V
Low signal Level	0	0	0.5	V	Signal voltage < 0.5V

Motor control

The G4 has its own motor drive with motor speed control function and a command interface instead of a hardware interface for motor control. Please refer to the development manual of this product for details.

Optical Characteristic

G4 uses an infrared point pulsed laser that meets FDA Class I laser safety standards. The laser and optical lens finish the transmission and reception of the laser signal to achieve high-frequency ranging while working. To ensure system ranging performance, please keep the laser and optical lens clean. The detailed optical parameters are as follows:

CHART5 YDLIDAR G4 LASER OPTICAL PARAMETERS

Item	Min	Typical	Max	Unit	Remarks
Laser wavelength	775	785	795	nm	Infrared band
FDA			⚠ Class I		

Polar coordinate system definition

In order to facilitate secondary development, G4 internally defines a polar coordinate system.

Pole: the center of the rotating core of the G4;

Positive direction: clockwise;

Zero angle: The zero angle is offset from the exit of the G4 PH2.0-5P interface line by 4° counterclockwise (top view) as shown:

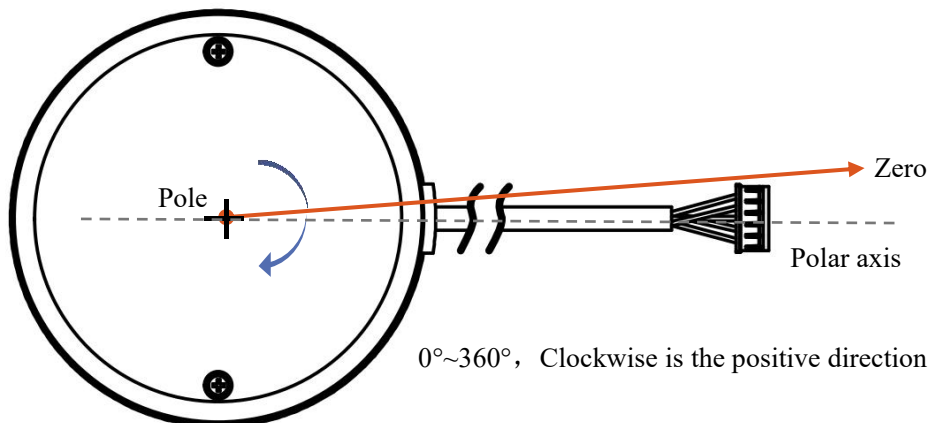

FIG4 YDLIDAR G4 POLAR COORDINATE SYSTEM DEFINITION

Note: When the Lidar is assembled on the machine, the deviation of the assembly may cause slight difference in the consistency of the zero position. For the convenience of use, we provide zero calibration software, which can customize the zero direction and assemble to the machine. The Lidar is calibrated twice. For details, please refer to the instruction manual.

Others

CHART7 YDLIDAR G4 OTHERS

Item	Min	Typical	Max	Unit	Remarks
Operating temperature	0	20	50	°C	长期工作在高温环境下，会降低寿命
Lighting environment	0	550	2000	Lux	仅作参考
weight	-	214	-	g	裸机重量

Development and support

With a wealth of hardware and software interfaces,G4 can support motor enable control, speed control, and enable control&output control of the ranging core. Thus,users can also implement the power control and scan control purpose.

Also, the 3D model is open.YDLIDAR provides the graphical debugging client-PointCloud Viewers,together with the corresponding SDK development kit and Ros development kit.

For the G4 development manual, SDK development manual and Ros manual,please download from our official website: www.ydlidar.com