

# **YDLIDAR X4**

## **DATASHEET**

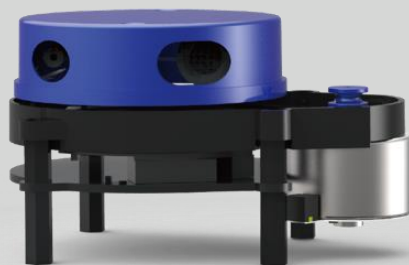

## CONTENTS

overview .....	2
Product Features .....	2
Applications .....	2
Installation and dimensions .....	2
SPECIFICATIONS .....	4
Product parameters .....	4
Electrical parameters .....	4
Interface definition .....	4
Data communication .....	5
Motor control .....	6
Optical characteristics .....	7
Polar coordinate definition .....	7
Others .....	8
Development and support .....	8

## OVERVIEW

The YDLIDAR X4 Lidar is a 360-degree two-dimensional distance measurement product (hereinafter referred to as X4) developed by the YDLIDAR team. This product is based on the principle of triangulation, and is equipped with relevant optics, electricity, and algorithm design to realize high-frequency and high-precision distance measurement. At the same time as the distance measurement, 360 degrees of scanning distance measurement is achieved by continuously obtaining the angle information through the 360 degree rotation of the motor.

### Product Features

- 360-degree scanning distance measurement
- Small distance error; stable distance measurement and high accuracy
- Wide ranging range, not less than 10m
- Strong resistance to ambient light interference
- Industrial grade brushless motor drive, stable performance
- Laser power meets Class I laser safety standards
- 360 degree omnidirectional scanning; 6-12Hz adaptive scanning frequency
- High-speed ranging, ranging frequency up to 5000hz

### Applications

- Robot navigation and obstacle avoidance
- Robot ROS teaching and research
- Regional security
- Environmental Scan and 3D Reconstruction
- Home service robot/sweeping robot navigation and obstacle avoidance

### Installation and dimensions

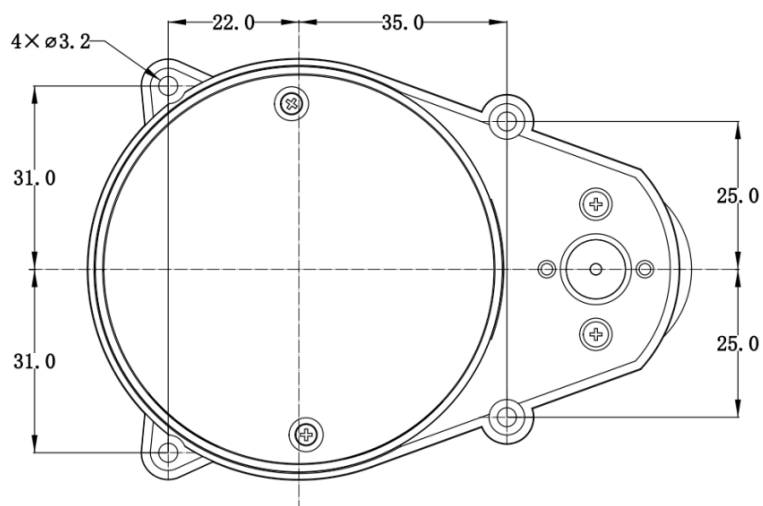

FIG 1 YDLIDAR X4I INSTALLATION AND DIMENSION I

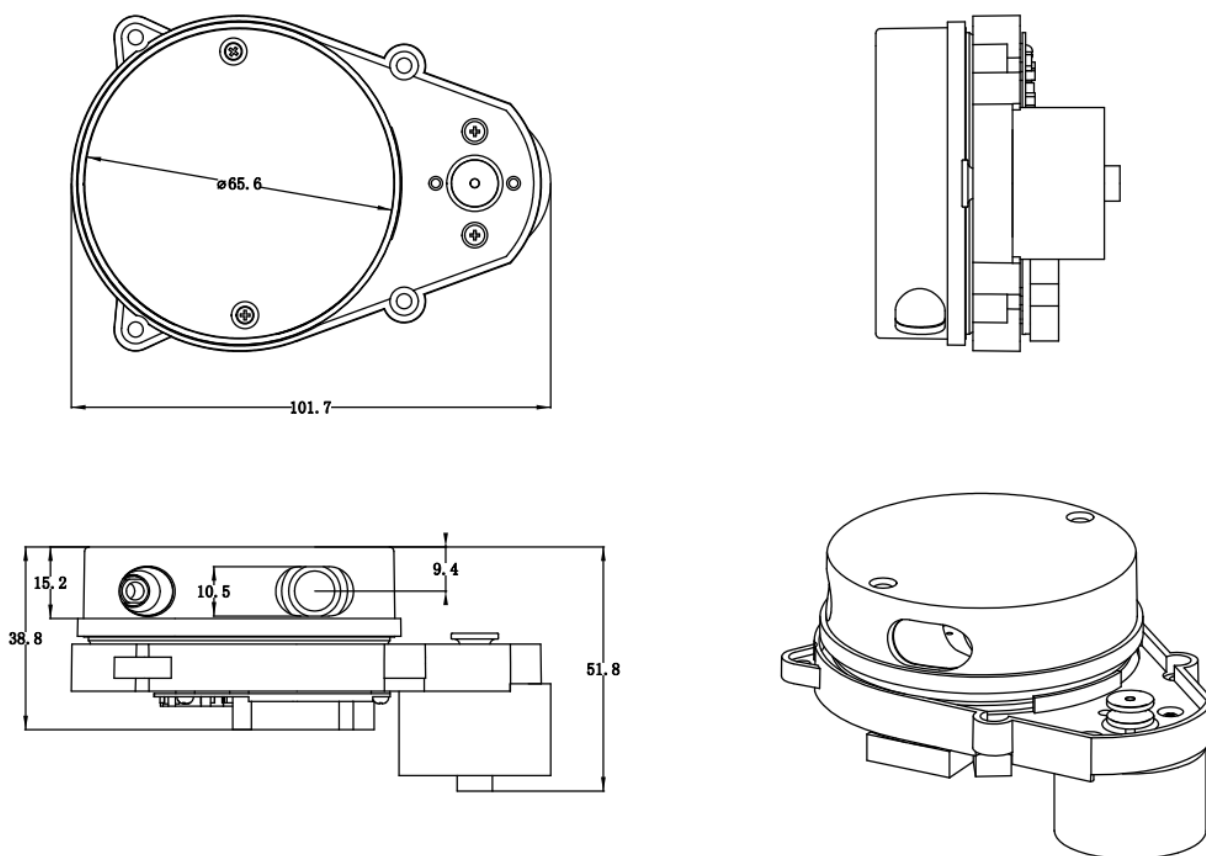

FIG 2 YDLIDAR X4 INSTALLATION AND DIMENSION II

# SPECIFICATIONS

## Product parameters

**CHART 1 YDLIDAR X4 PRODUCT PARAMETERS**

Item	Min.	Typical Value	Max.	Unit	Remark
Range Frequency	-	5000	-	Hz	5000 range sampling per second
Scanning Frequency	6	-	12	Hz	Configurable by software
Range	0.12	-	>10	m	Indoor
Scanning Angle	-	0~360	-	Deg	-
Range resolution	-	<0.5	-	mm	Range<2m
		< 1% of actual distance			Range>2m
Angle resolution	0.48	0.50	0.52	Deg	Scanning Frequency 7Hz
Working life	-	1500	-	h	Continuous working life

## Electrical parameters

**CHART 2 YDLIDAR X4 ELECTRICAL PARAMETERS**

Item	Min.	Typical Value	Max.	Unit	Remark
Supply voltage	4.8	5	5.2	V	Excessive voltage can damage the device. Low voltage can affect performance.
Voltage ripple	0	50	100	mV	High ripple affects performance and can even cause Lidar to fail to range
Starting current	400	450	480	mA	High current at startup
Sleep current	280	300	340	mA	System sleeps, motor does not rotate
Working current	330	350	380	mA	System work, motor rotates

## Interface definition

The X4 provides a PH2.0-8P female connector. The interface has functional interfaces for system power, data communications, and motor control.

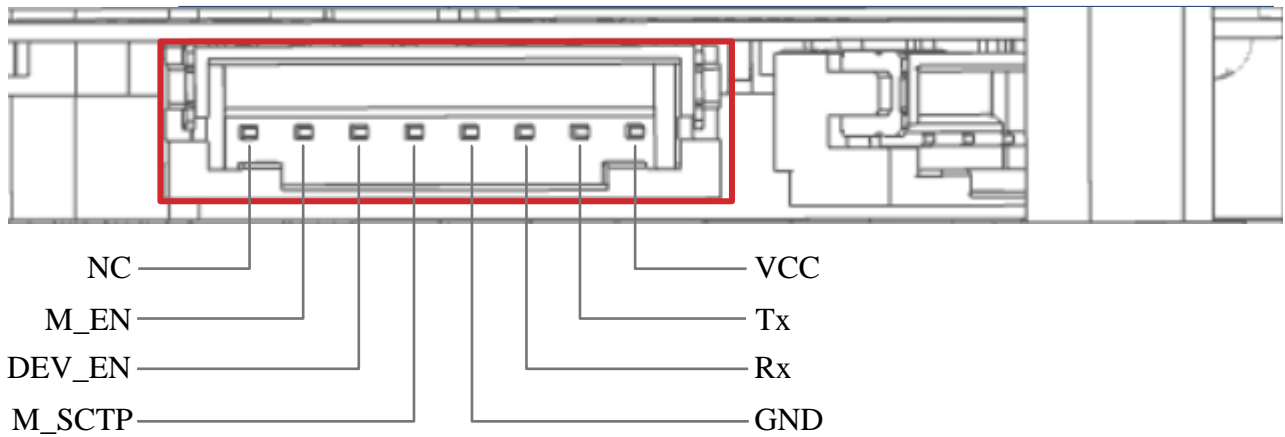

FIG 3 YDLIDAR X4 INTERFACES

### CHART 3 YDLIDAR X4 INTERFACE DEFINITION

Pin	Type	Description	Default	Range	Remark
VCC	Power supply	voltage positive	5V	4.8V~5.2V	-
Tx	Output	System serial output	-	-	Data Stream: Lidar → Peripherals
Rx	Input	System serial port input	-	-	Data Stream: Peripherals → Lidar
GND	Power Supply	voltage negative	0V	0V	-
M_EN	Input	Motor enable control	3.3V	0V~3.3V	-
DEV_EN	Input	Ranging enable control	3.3V	0V~3.3V	-
M_SCTP	Input	Motor speed control	1.8V	0V~3.3V	Voltage speed regulation or PWM speed regulation
NC	-	Reserved pin	-	-	-

### Data communication

The X4 communicates using a 3.3V level serial port (UART). The user can connect the external system and the product through the physical interface on the product. And in accordance with the communication protocol of the system to obtain real-time scanning point cloud data, device information, device status, and set the device work mode. The communication parameters are as follows:

### CHART 4 YDLIDAR X4 SERIAL SPECIFICATIONS

Item	Min.	Typical Value	Max.	Unit	Remark
Baud rate	-	128000	-	bps	8 data bits, 1 stop bit, no parity
Signal high	1.8	3.3	3.5	V	When the signal voltage is >1.8V, it is high level
Signal low	0	0	0.5	V	When the signal voltage is <0.5V, it is low level

### Motor control

X4 comes with motor speed control motor driver. The peripheral can control the motor of X4 by inputting the control signal via two pins M\_EN and M\_SCTR in the interface. M\_EN is the enable signal of the motor, and the high level is enabled; M\_SCTR is the motor speed control signal, which can be adjusted by voltage or PWM wave. The lower the voltage / the smaller the PWM duty cycle, the higher the motor speed. The maximum speed is 0V/0% duty cycle.

For example: M\_EN is high level, M\_SCTR input voltage is 0V, the motor rotates at the highest speed.

There are the following requirements for the PWM signal of M\_SCTR:

### CHART 5 YDLIDAR X4 MOTOR PWM SIGNAL SPECIFICATIONS

Item	Min.	Typical Value	Max.	Unit	Remark
PWM frequency	-	10	-	KHz	PWM is a square wave signal
Duty cycle range	50%	85%	100%		The shorter the duty cycle, the faster the speed

## Optical characteristics

The X4 uses infrared point pulsed lasers that meet FDA Class I laser safety standards. When the system is working, lasers and optical lenses complete the transmission and reception of laser signals to achieve high-frequency ranging. To ensure the performance of the system ranging, please make sure that the X4's laser and optical lens are kept clean. The laser optical parameters are as follows:

**CHART 6 YDLIDAR X4 OPTICAL**

Item	Min.	Typical Value	Max.	Unit	Remark
Laser wavelength	775	785	795	nm	Infrared band
Laser power	-	3	5	mW	Peak power
FDA	⚠ Class I				

## Polar coordinate definition

In order to facilitate the secondary development, X4 internally defines the polar coordinate system. The polar coordinate of the system is the pole of the center of rotation of X4, and the specified angle is clockwise positive. The zero angle is located directly in front of the X4 motor as shown in the figure:



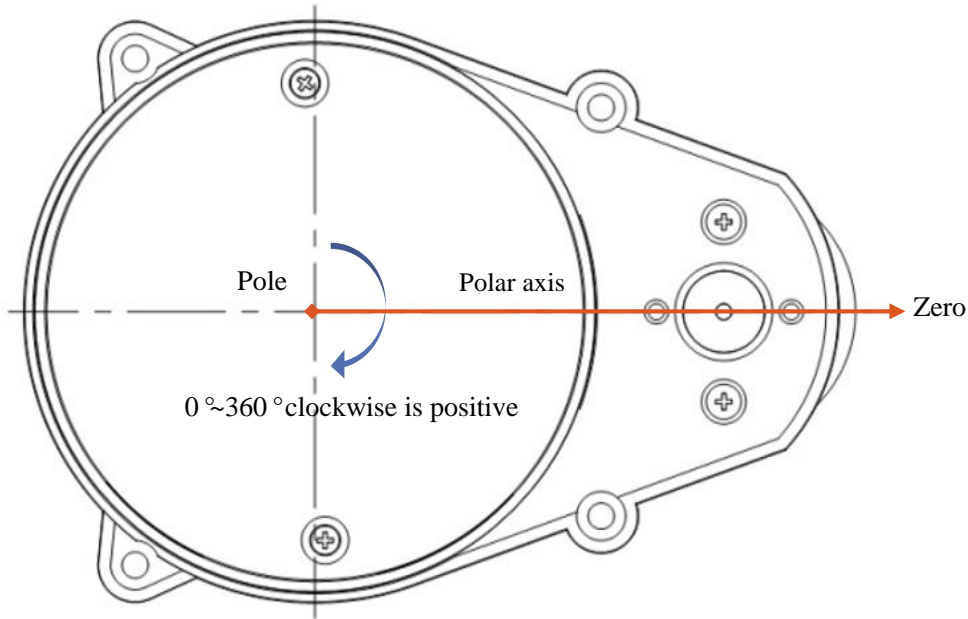

FIG 4 YDLIDAR X4 POLAR COORDINATE DEFINITION

## Others

### CHART 7 YDLIDAR X4 OTHERS

Item	Min.	Typical Value	Max.	Unit	Remark
Working temperature	0	20	40	°C	Long-term work in high temperature environment will reduce the working life
Lighting environment	0	550	2000	Lux	For reference only
N.W.	-	180	-	g	-

## DEVELOPMENT AND SUPPORT

X4 provides a wealth of hardware and software interfaces that enable motor-enable control, speed control, ranging control, and output control of the system. Users can implement power control and scan control on the X4. At the same time, the 3D model of the product is also open, and the user is provided with a graphical debugging client under Windows, as well as a corresponding SDK development kit and a ROS development kit. The user can download from the official website. <http://www.ydlidar.com/>