

Comment(0)

Prominent Safety

The remarkable protection functions prolong the service life and enhances safety.

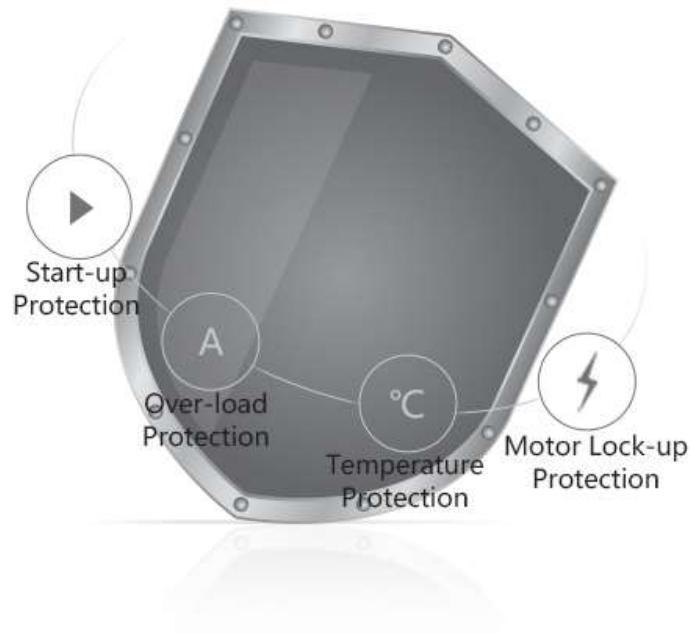

Layered structure, efficient and reasonable heat dissipation.

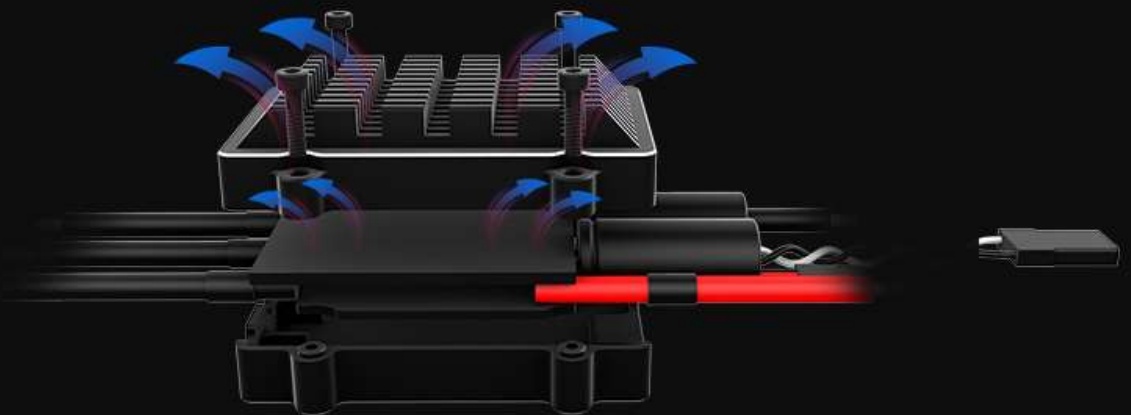

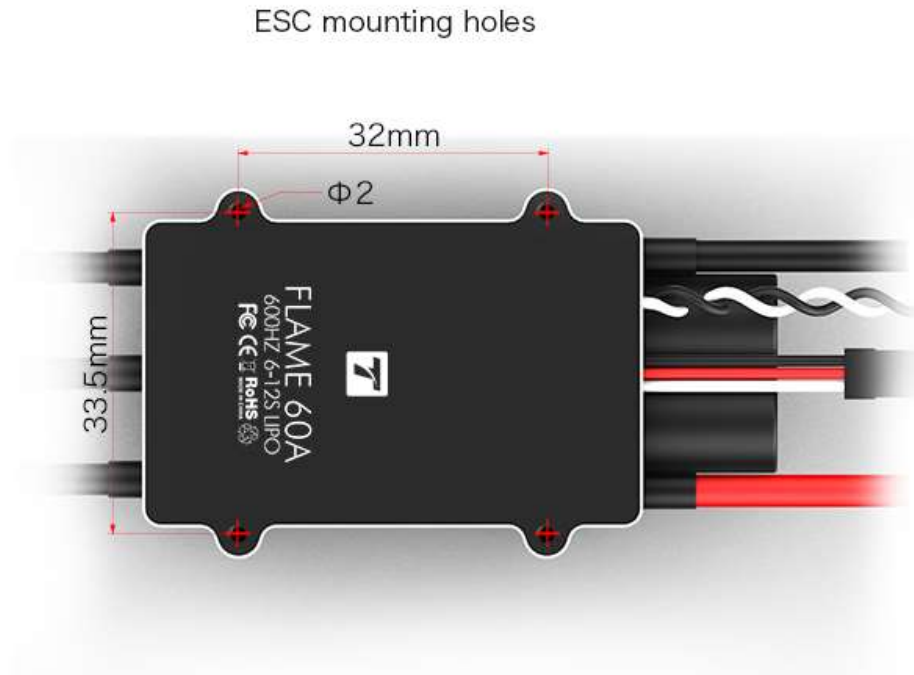

FLAME (Industrial) ESC User Manual

DISCLAIMER

Thanks for purchasing our Electronic Speed Controller (ESC). High power system for RC model can be very dangerous. Any improper use may result in injury and damage to human and devices. We strongly recommend that you read this manual carefully before use, and abide by its rules. We assume no responsibility for personal injury, property damage or consequential losses resulting from the product.

USER GUIDE

Model	Continuous Current	Peak Current (10S)	BEC	LiPo	Programable Item(s)	Weight (g)	Size / L*W*H (MM)
FLAME 60A HV	60A	80A	NO	6-12S	NO	73.5	66.5*38.5*17.7
FLAME 70A LV	60A	80A	NO	4-6S	NO	55	56.6*36.4*16.1
FLAME 80A HV	80A	120A	NO	6-12S	Timing (High/Intermediate)	106	62*41*17
FLAME 100A LV	100A	120A	NO	4-8S	NO	78.5	72.2*30.6*17.3
FLAME 100A HV	100A	120A	NO	6-14S	NO	139	86.1*54.1*24
FLAME 180A HV	180A	200A	NO	4-14S	NO	279	112.2*50.5*35.5

⚠ To avoid irreparable damage to ESCs, please keep strict compliance with the input voltage range !

THROTTLE CALIBRATION

*Please calibrate the throttle range when you use a new FLAME ESC or RC.

Step 1: Wiring Diagram

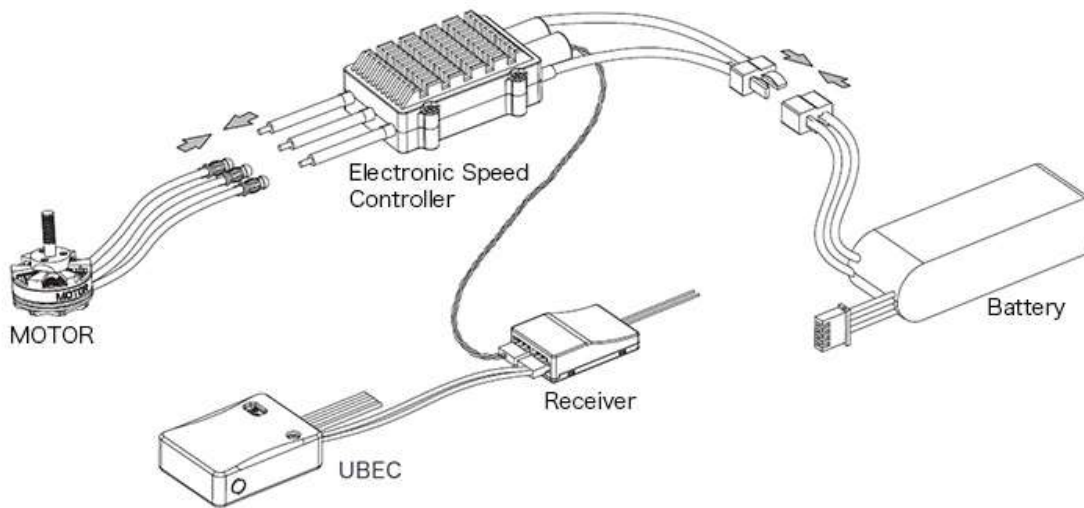

Step 2: Throttle Range Calibration

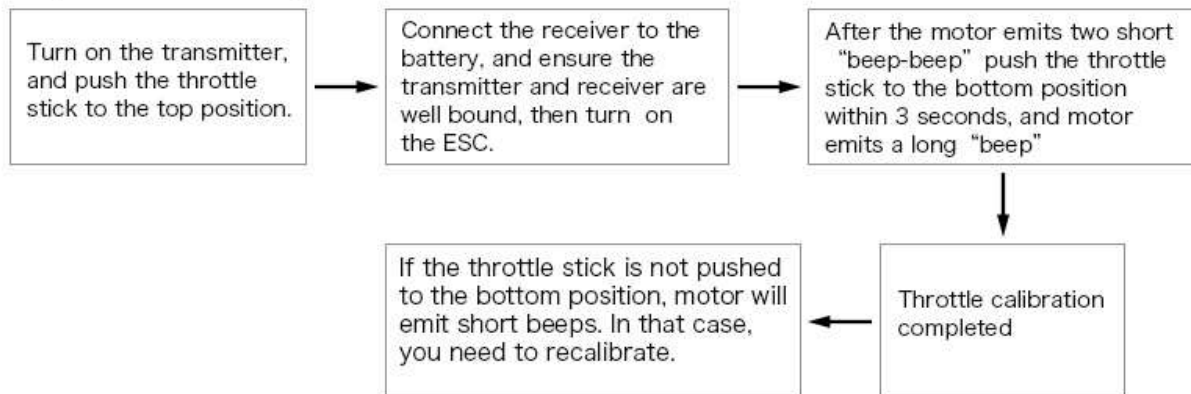

⚠ For safety sake, please remove the propellers during throttle calibration !

NORMAL STARTUP PROCESS

Turn on the transmitter and push the throttle stick to the bottom position.



The motor will emit a long “beep—” 1 second after the system is connected to the battery which indicates the ESC and the multi-rotor are ready.

PROTECTIONS

This ESC is specially designed for multi-rotors.

- 1、 **Start-up Protection:** The ESC will shut down the motor when it fails to start the motor normally in 2 seconds by increasing the throttle value. In this case, you need to move the transmitter throttle stick back to the bottom position and restart the motor.(Possible causes: poor connection or disconnection between ESC and motor wires; propellers are blocked etc.)
- 2、 **Throttle Signal Loss Protection:** When the ESC detects loss of signal for over 0.25 second, it will cut off the output immediately to avoid greater loss which may be caused by the continuous high-speed rotation of propellers or rotor blades. ESC will resume the corresponding output when normal signals are received.
- 3、 **Motor Lock-up Protection:** The ESC will try to restart the motor (thrice) when motor lock-up is detected; if it fails, it will cut off the output and stop attempting. To restart the ESC and resume its output, you need to push the throttle stick to the bottom position and then start again.
- 4、 **Over-load Protection:** The ESC will cut off its output immediately when the peak current gets close to 340A(short-circuit current). Please regain its normality by powering it on.

TROUBLE SHOOTING

Trouble	Warning Tone	Possible Cause	Solution
The esc was unable to start the motor	“Beep beep beep...” (the motor beeped rapidly)	The throttle stick was not on the bottom position or the throttle range was too narrow	Move the throttle stick to the bottom position or recalibrate the throttle range
The esc was unable to start the motor	“Beep、 beep、 beep...” (time interval is 1 second)	No output signal emitted from the throttle channel on the receiver	Check if the transmitter and receiver are well bound Check if the throttle wire has been properly plugged into the channel into the receiver
The esc was unable to start the motor	“Beep beep、 beep beep...” (these tones are played circularly)	The voltage was below 18.6v	Change another battery with normal voltage(18.6-55v)
The esc was unable to start the motor	“beep beep beep、 beep beep beep...” (these tones are played circularly)	The voltage was above 55v	Change another battery with normal voltage (18.6-55v)

If you encounter any problems using FLAME ESC, please feel free to contact our distributors or T-MOTOR directly.