

### 128Mb Flash

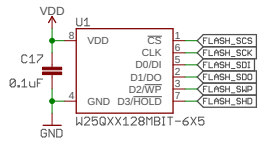

### 32.768kHz RTC Crystal

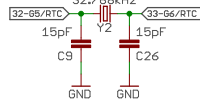

### MicroMod Connector

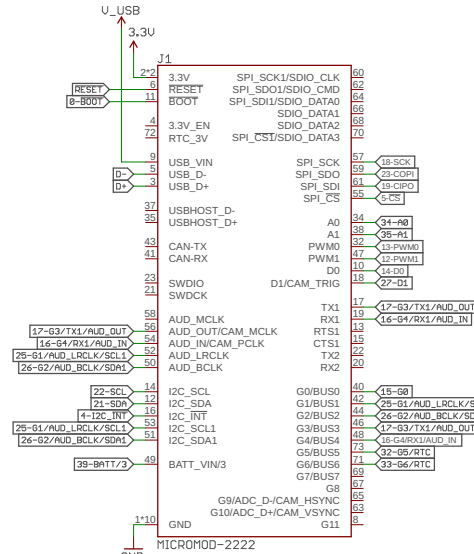

### CP2104/2N (USB-to-Serial Converter)

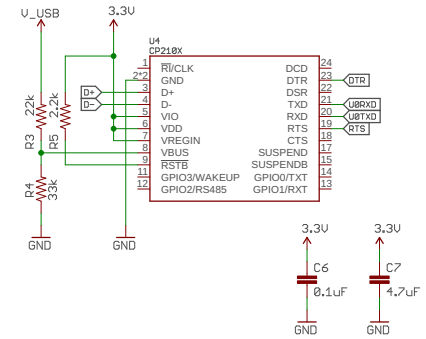

### Espressif ESP32

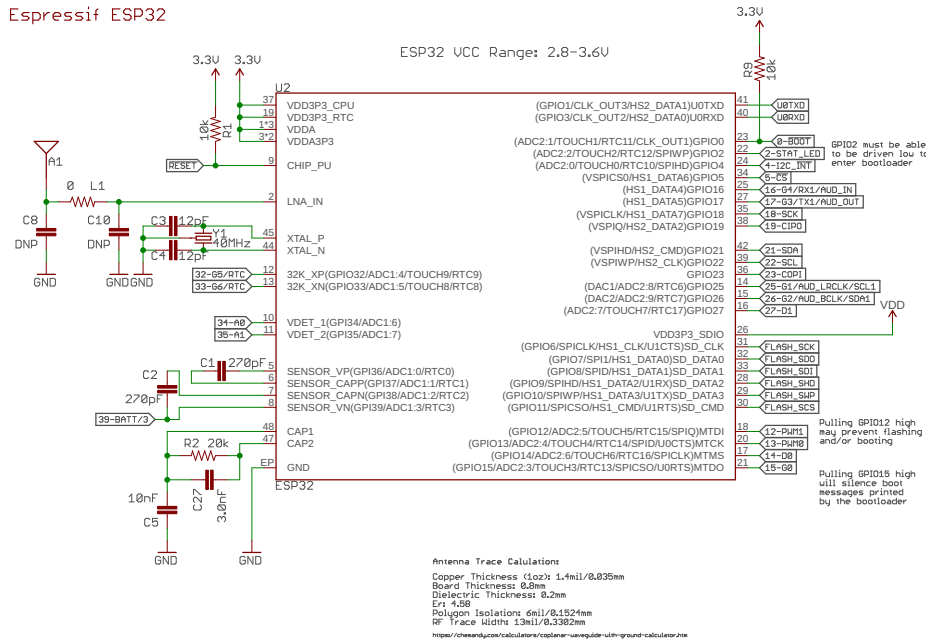

### Auto-Reset

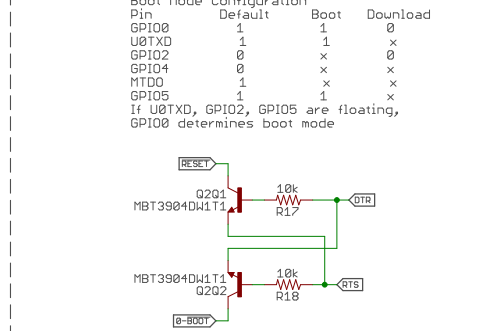

If DTR is LOW, toggling RTS from HIGH to LOW resets to run mode.  
 If RTS is HIGH, toggling DTR from LOW to HIGH resets to bootloader.

### Status LED

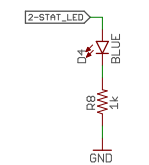

### Special Instructions

Released under the Creative Commons Attribution Share-Alike 4.0 License  
<https://creativecommons.org/licenses/by-sa/4.0/>

TITLE: SparkFun\_MicroMod\_ESP32

Design by: Alex Wende

Date: 9/22/2020 10:40 AM

REU: v11

Sheet: 1/1

