

SHERLINE PRODUCTS

INCORPORATED 1974

MILL VISE

P/N 3551

Figure 1—
Pull-Down Feature

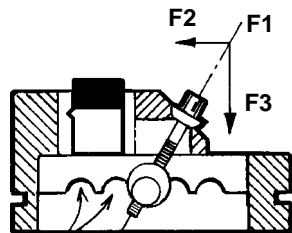

APPROXIMATE ADJUSTMENT SLOTS
ADJUSTMENT RANGE:
46° TO 60°

INSTRUCTIONS

The advantages of this vise are obvious when movement of the jaw is studied. (See Figure 1 and look at the bottom of your vise.) The tightening force (F1) produces not only a force against the part (F2), but also a force pulling the jaw downward (F3). Therefore, angle "A" must exceed 45° in order to make force F3 greater than F2. This keeps the movable jaw from "tipping" back. Also note that extreme clamping angles beyond 60° start to apply much downward pressure but not much horizontal force is directed to holding the part. Moving the pull-down barrel to the proper slot keeps the adjustment within the most effective clamping range.

To clamp a part, place the jaw in approximate position and start tightening the adjustment screw at an angle of 45° or greater. (The back face of the moveable jaw is machined at a 45° angle for reference.) If the angle of the adjustment screw gets up to 60° or greater and you still haven't drawn down on the part, loosen up the screw a little and move the pull-down barrel to the next slot and retighten.

Figure 2 shows the proper way to hold a part in the vise. If the part cannot be centered, use a spacer to help keep the jaws parallel. This vise has been designed to accurately hold objects being machined. It is not recommended for use as a bench vise or for clamping parts in such a way and with such force as to adversely affect its accuracy.

Joe Martin, President and Owner
Sherline Products Inc.

NOTE: To keep the surface of your table from being marred, we recommend you take a file and slightly soften or deburr all the edges of the angle clamps that contact the table.

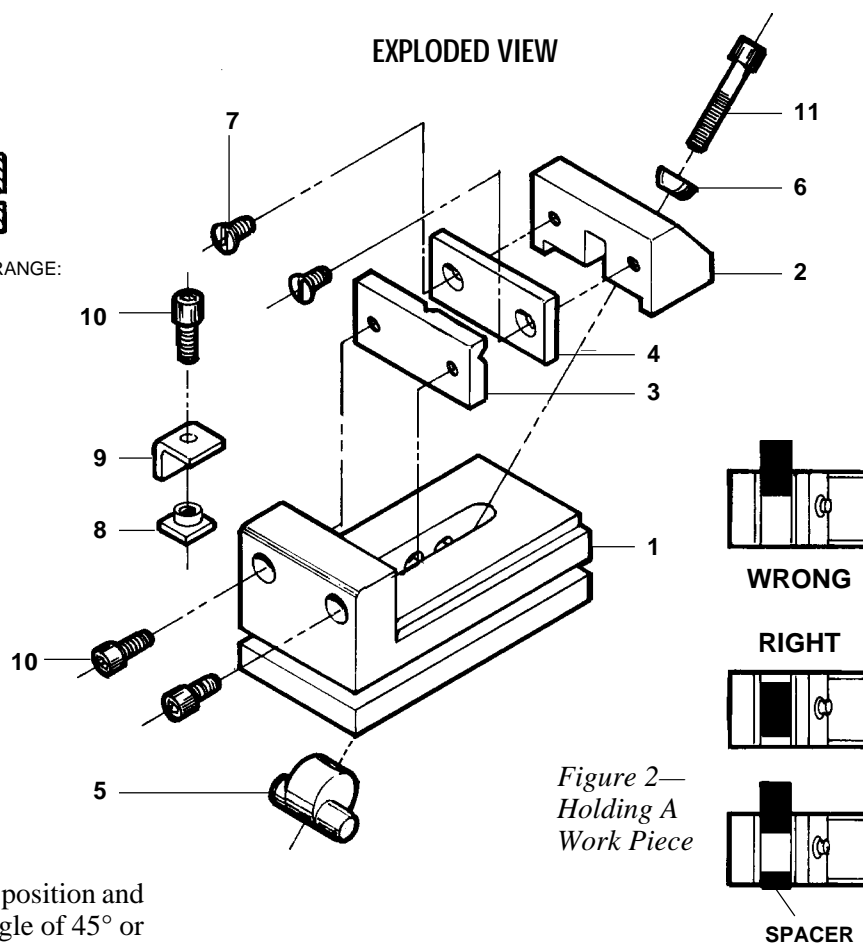

Figure 2—
Holding A
Work Piece

MILL VISE PARTS LIST

REF NO.	PART NO.	DESCRIPTION
1	35100	Vise body
2	35020	Movable jaw
3	35030	Fixed jaw insert
4	35040	Movable jaw insert
5	35120	Pull-down member
6	35060	Convex washer
7	35070	Flat head screw, 6-32 x 3/8 (2)
8	30561	T-nut, 10-32 (2)
9	35580	Hold-down clamp (2)
10	40330	Skt hd cap screw, 10-32 x 5/8" (4)
11	35130	Skt hd cap screw, 10-32 x 1-5/8"