



SHERLINE PRODUCTS

INCORPORATED 1974

Miniature Lathe and Milling Machine Assembly and Instruction Guide



Eighth Edition

P/N 5326

©2017, Sherline Products Inc.

Full One-Year Warranty on Sherline's 3.5" Metal Lathe, Vertical Milling Machine, and Accessories

If within one year from the date of purchase a new* Sherline power tool fails due to a defect in material or workmanship, Sherline will repair it free of charge. In addition, it has always been our policy to replace all parts at no cost, regardless of age, which are determined to have been incorrectly manufactured or assembled and have failed due to this cause rather than because of improper use or excessive wear caused by continuous use in a production environment.

90-Day Warranty on CNC and Computer-Related Components

If a new* CNC or computer-related component sold by Sherline fails within 90 days of purchase Sherline will repair it free of charge. These components include, but are not limited to, controllers, driver boxes, stepper motor cables, computers, and other computer-related components.

Right of Inspection

Sherline will inspect the machine or part and will be the sole judge of the merit of the claim. Freight charges for returning a machine are not covered. Merchandise which has been abused or misused is not subject to warranty protection. Disassembly of a machine or accessory beyond normal maintenance procedures described in this manual may void the warranty. Before attempting major repairs, call the factory for advice and instructions.

Warranty service is available by simply returning the machine, defective assembly, or part to:

Sherline Products, Inc., 3235 Executive Ridge, Vista, CA 92081-8527

Please write, fax, call, or email to let us know that you are returning a part and to receive a return authorization number. This will speed up the warranty process (Email is sherline@sherline.com)

This warranty gives you specific legal rights, and you may also have other rights which vary from state to state.

***NOTE:** Only new machines purchased directly from Sherline or from an authorized Sherline dealer are covered by this warranty. This includes machines purchased via on-line auctions when offered by Sherline or its authorized dealers. Machines purchased second-hand or from a non-authorized dealer are considered "used" and are not subject to warranty even if they appear to be new in the box. If you are in doubt about the status of a dealer or are suspicious about an offer that doesn't seem quite right, you can always confirm a dealer's status by checking our DEALERS page (sherline.com/authorized-sherline-dealers/) for a listing or by calling (800) 541-0735 to confirm a dealer's authority to represent Sherline.

Sherline Service Policy

Sherline's policy regarding customer service is simple: CUSTOMER SATISFACTION!

Because products manufactured by Sherline are produced and assembled in our Vista, California plant, we offer fast and reasonably priced service. All we ask when you pack the items for shipping is to use common sense, individually protecting items from one another during shipping. Ship by UPS or FedEx ground whenever possible. If you have attempted a repair and then decide to return the item it is not necessary to reassemble the machine. If you have lost a part, don't worry, we'll still get it looking great for you and return it via UPS or FedEx*. Work and parts not covered under warranty can be charged to your credit card for your convenience or we can call with an estimate at your request before performing any work. Again, please email or call Sherline to obtain an RMA number before returning anything for service. Cleaning the returned items thoroughly before you ship them will save time and money.

*If merchandise is received damaged by the shipper, keep the original shipping carton and contact us to let us know that your package was damaged.

How to Order Replacement Parts

The model number of your machine will be found on the chrome nameplate attached to the top or side of the headstock. The serial number is laser engraved into the back of the headstock. Always mention the model number when requesting service or repair parts for your machine or accessories.

Replacement parts may be ordered from the factory or from any Sherline dealer. The most expeditious way to order parts is directly from the factory by phone, fax or our website at www.sherline.com. Office hours are 8 AM to 4 PM (PST or PDT) Monday through Friday. We do our best to see that orders received before 12 noon (Pacific Standard or Daylight Time) will be shipped the same day. We accept payment by Visa, MasterCard, Discover or American Express.

Parts Orders:

Toll free order line: (USA and Canada) 1-800-541-0735

International or Technical Assistance: 1-760-727-5857 • Fax: 760-727-7857

Websites: For information, or to place orders 24 hours a day, visit www.sherline.com

Electronic Line Filter makes Sherline Tools CE Compliant

As countries around the world have tightened up their import regulations, Sherline has taken the extra step to make available an in-line electronic filter between the DC motor speed control and the incoming AC current in order to meet CE standards. Users outside the USA will only need to supply a wall plug adapter to go from the American style 3-prong plug to the type of plug used in your country. An extra charge applies for machines ordered with this filter installed, but the shipping box will state that the machine complies with CE standards. We highly recommend that customers in countries requiring CE certification order this part in order to avoid possible problems with customs.



The line filter cuts electronic emissions to meet CE standards.

CE Filter added to any machine: Part number plus letters -CE, Retrofit filter/cord only: P/N 45500

Table of Contents

Safety Rules for Power Tools	2	Helpful Tips for Milling	27
An Introduction to the World of Miniature Machining.....	3	Securing the Workpiece	28
General Precautions	3	Locking the Axes	28
Machine Terminology	4	Before You Start Cutting	28
The Customer's Responsibility	5	Purchasing Materials in Small Quantities	28
Learning More About Machining	5	Three Types of Work	29
Visit the Sherline Website for the Latest Updates	5	Types of Milling Cutters	29
Lubrication	5	Standard Milling Versus Climb Milling	29
Initial Assembly of a New Machine	5	Using a Dial Indicator	30
Installing the Lathe Crossslide	6	Locating the Edge of a Part	31
Installing the Mill X-Axis Handwheel	6	Determining the Depth of Cut	31
Installing the Mill X-axis Digital Readout Handwheels	6	Cutting Speeds for Milling	32
5000/5400-Series Mills—Mounting the Column	6	End Mills	32
2000/5800-Series Mills—Assembling and Mounting the Multi-Direction Column	7	Using the Mill Column Saddle Lock	32
Mounting the Motor and Speed Control Assembly	7	Accessories for Your Milling Machine	33
Operation of the Motor and Electronic Speed Control	10	Sensitive Drilling Attachment	33
What to Do if the Motor Suddenly Shuts Down	10	3/8" End Mill Holder	33
Replacing Brushes on a DC Motor	10	Drill Chuck Holder	33
Mounting the Lathe or Mill to a Board for Stability	10	Mill Collet Set	33
Converting Machines from Inch to Metric	11	Boring Head	33
Adjustments	11	Fly Cutters	34
Two-Speed Pulley	11	Drill Chucks and Center Drills	34
Spindle Preload	11	Mill Vise Set	34
Gib	11	Tilting Angle Table	35
Leadscrew Backlash (Lathe and Mill)	12	4" Rotary Table (Manual and CNC-Ready)	35
Handwheels (Lathe and Mill)	12	CNC Rotary Indexer	36
Saddle Nut (Lathe and Mill)	12	CNC and CNC-Ready Systems	36
Adjustment and Use of the Tailstock Gib	12	Learning about CNC	36
Aligning the Headstock and Tailstock	13	Several Reasons to Consider CNC	36
Squaring up Your Mill	13	Longer Tables and Taller Milling Columns Available	37
Use of Cutting Oils and Lubricants	17	10,000 RPM Spindle Pulley Set	37
General Machining Terms	17	Industrial Applications for Sherline Components	37
Lathe Operation	18	DRO Machine Operations	37
Leveling the Cutting Tool	18	The Digital Readout in the Modern Machine Shop	37
Initial Test Cutting	18	Installing the DRO Components	38
Inducing Chatter and Learning How to Overcome It	19	Making Sure the Housings Do not Move	40
Holding the Workpiece	19	Installing the RPM Sensor	40
Turning Between Centers	19	Hooking up the Connecting Cables	40
Removing Tools from the Morse Taper Spindles	19	Initializing the Display for Inch/Metric Leadscrews	40
Center Drilling	20	Setting the Backlash Compensation Values	41
Tailstock Drilling	20	Adjusting the Z-Axis Handwheel Screw	41
Headstock Drilling	20	Reverse Direction of the Reading on the X-axis	41
Reaming	20	Getting the Most out of Your DRO	42
Faceplate Turning	20	Installing Stepper Motors	42
Taper Turning	20	Stepper Motor Installation Instructions	42
Tool Shapes and Grinding Your Own Cutting Tools	21	Using Handwheels on the Stepper Motors	43
Using the Cutoff or Parting Tool	22	Sherline Stepper Motor Specifications	43
Inserted Tip Carbide Tools	23	Lead Wire Connection and Color Code	43
Guide to Approximate Turning Speeds	24	Sherline CNC Motor-Mounting Instructions	44
Accessories for Your Lathe	24	Lathe and Mill Exploded Views	45
3-Jaw, 4-Jaw and Drill Chucks	24	Exploded view, manual 4000/4400-series lathes	45
Thread Cutting Attachment	25	Exploded view, CNC 4000/4400-series lathes	46
Steady Rest	25	Exploded view, manual 5000/5400-series mills	47
Live Center	25	Exploded view, CNC 5000/5400-series mills	48
Digital Readouts	25	Exploded view, manual 2000 series 8-direction mill	49
3-Jaw Chuck Operation and Maintenance	26	Exploded view, CNC 2000-series 8-direction mill	50
Vertical Milling Machine Operation	26	Exploded view, manual 5800-series Nexgen mill	51
General Description	26	Exploded view, CNC 5800-series Nexgen mill	52
		Machining Basics—Using the Handwheels	53
		Sherline Machine Technical Specifications	53

Safety Rules for Power Tools

- 1. Know Your Power Tool**—Read the owner's manual carefully. Learn its application and limitations as well as the specific potential hazards peculiar to this tool.
- 2. Ground All Tools**—If a tool is equipped with a three-prong plug, it should be plugged into a three-hole receptacle. If an adapter is used to accommodate a two-prong receptacle, the adapter wire must be attached to a KNOWN GROUND. Never remove the third prong. (See Figure 1.)
- 3. Keep Guards in Place**—and in working order.
- 4. Remove Adjusting Keys and Wrenches**—Form a habit of checking to see that keys and adjusting wrenches are removed from the tool before turning on any machine.
- 5. Keep Work Area Clean**—Cluttered areas and benches invite accidents.
- 6. Avoid a Dangerous Work Environment**—Do not use power tools in damp or wet locations. Keep your work area well illuminated.
- 7. Keep Children Away**—All visitors should be kept a safe distance from the work area.
- 8. Make Your Workshop Childproof**—with padlocks, master switches or by removing starter keys.
- 9. Do Not Force a Tool**—Do not force a tool or attachment to do a job for which it was not designed. Use the proper tool or accessory for the job.
- 10. Wear Proper Apparel**—Avoid loose clothing, neckties, gloves or jewelry that could become caught in moving parts. Wear protective headgear to keep long hair styles away from moving parts.
- 11. Use Safety Glasses**—Also use a face or dust mask if a cutting operation is dusty.
- 12. Secure Your Work**—Use clamps or a vise to hold work when practicable. It is safer than using your hand and frees both hands to operate the tool.
- 13. Do Not Overreach**—Keep your proper footing and balance at all times.
- 14. Maintain Tools in Top Condition**—Keep tools sharp and clean for best and safest performance. Follow instructions for lubrication and changing accessories.
- 15. Disconnect Tools**—Unplug tools before servicing, or when changing accessories such as blades, bits or cutters.
- 16. Avoid Accidental Starting**—Make sure the switch is "OFF" before plugging in a power cord.
- 17. Use Recommended Accessories**—Consult the owner's manual. Use of improper accessories may be hazardous.
- 18. Turn the Spindle by Hand Before Switching Motor On**—This ensures that the workpiece or chuck jaws will not hit the lathe bed, saddle, crossslide or cutting tool and that a key or spindle bar was not left in the chuck.
- 19. Check that all Holding, Locking and Driving Devices Are Tightened**—At the same time, be careful not to overtighten these adjustments. They should be just tight enough to do the job. Overtightening may damage threads or warp parts, thereby reducing accuracy and effectiveness.
- 20. Don't Use Your Lathe for Grinding**—The fine dust that results from the grinding operation is extremely hard

on bearings and other moving parts of your tool. For the same reason, if the lathe or any other precision tool is kept near an operating grinder, it should be kept covered when not in use.

21. Don't Let Long, Thin Stock Protrude from the Back of the Spindle—Long, thin stock that is unsupported and turned at high RPM can suddenly bend and whip around.

22. Wear Your Safety Glasses—Foresight is better than NO SIGHT! The operation of any power tool can result in foreign objects being thrown into the eyes, which can result in severe eye damage. Always wear safety glasses or eye shields before commencing power tool operation. We recommend a Wide Vision Safety Mask for use over spectacles or standard safety glasses.

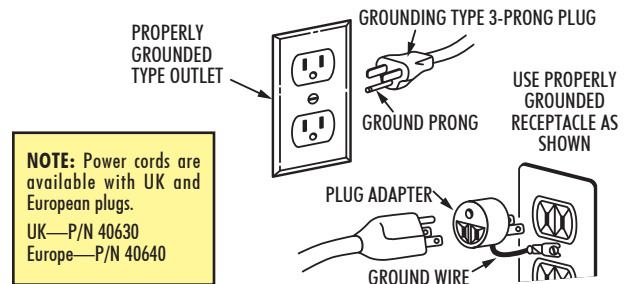

FIGURE 1—Proper grounding for electrical connections.

Electrical Connections

The power cord supplied is equipped with a 3-prong grounding plug that should be connected only to a properly grounded receptacle for your safety. Should an electrical failure occur in the motor, the grounded plug and receptacle will protect the user from electrical shock. If a properly grounded receptacle is not available, use a grounding adapter to adapt the 3-prong plug to a properly grounded receptacle by attaching the grounding lead from the adapter to the receptacle cover screw.

NOTE: The electrical circuit designed into the speed control of your lathe or mill reads incoming current from 100 to 240 volts AC and 50 or 60 Hz and automatically adapts to supply the correct 90 volts DC to the motor. As long as you have a properly wired, grounded connector cord for your source, the machine will operate anywhere in the world without a transformer. This has been true for all Sherline machines built since 1994. Prior to that, an AC/DC motor was used. Use that motor ONLY with the power source for which it was intended. It will not automatically adapt to any other current and using it with an improper power source will burn out the motor or speed control. Also, the first few DC units built did not include the circuits to adapt to other currents. If you think you may have an early DC model, remove the plastic speed control housing and look for a label on the aluminum speed control frame. If it has a small metallic label on top of the frame that lists input voltage as 120VAC, DO NOT ATTEMPT TO CONVERT THIS MODEL TO OTHER CURRENTS. Models that can be used with any current have a paper label on the end of the speed control frame which lists the model number as KBLC-240DS.

See inside cover for information on ordering an optional CE compliant electronic filter if required in your country.

An Introduction to the World of Miniature Machining

Getting Answers to Your Questions About Machining

Over the years we have found that the majority of our customers are both highly intelligent and skilled craftsmen. Often they are also new to machining. The instructions we have included in this book, while far more extensive than anything included with other machine tools—even ones costing thousands of dollars—still only scratch the surface when it comes to machining. We have tried to anticipate the most common problems and questions asked by a new machinist. What we have provided in this book and with each accessory, when combined with a liberal amount of common sense, is more than enough to get you started. If you apply what you learn here, you will be well on your way to making good parts. No doubt you will also have many questions specific to your project that simply can't be addressed in a manual of this type.

Answers to questions beyond the scope of this booklet will have to come from your own research. Bookstores and libraries are full of excellent books on machining, and the Internet offers some great user groups that can put you in direct contact with others who share your specific interests. Our own website is a great source of information as well. We have published there all the instructions for all our tools and accessories for you to read and print out for free. There are also links to many other fascinating sites. We have found *Machinery's Handbook* to be a great resource to turn to answer many of your questions.

Sherline founder, Joe Martin, wrote a book called *Tabletop Machining* that is specifically directed to the owners of Sherline tools and to anyone who wants to learn to make small metal parts. The instructions you are reading that come with your machine are quite complete, however, if you want to get into more detail or want to see color photos of setups and projects made by some of the best craftsmen around, we are sure you will find more than your money's worth in *Tabletop Machining*. May your journey toward becoming a skilled machinist be an enjoyable one.

What New Machinists Like Most and Least

If you are new to machining, you may find it to be either one of the most rewarding skills one can learn or the most frustrating thing you have ever attempted. What makes machining fun for some is the complexity and challenge. The same thing will drive others up the wall. One customer may be overjoyed because he can now make parts that were not available for purchase. Another may wonder why he just spent all day making a part that is similar to one he could have purchased for two dollars. The difference is that it is not the same as the two-dollar part—it is *exactly* the part needed.

There Are no Shortcuts

Machining is a slow process because parts are made one at

a time. The interesting thing is, a skilled machinist may take almost as long to make the same part as a novice. Shortcuts usually end in failure. Unlike some other trades, mistakes cannot be covered up. There are no erasers, white-out or "putting-on tools" for machinists; you simply start over. To expand a little on an old rule: "*Think three times, measure twice and cut once!*"

The Craftsman's Strength—Anticipating a Tool's Limitations

The skill in machining isn't just "moving the dials." It is a combination of engineering and craftsmanship. A file is just as useful a tool to a good machinist as a multi-thousand-dollar machine tool. Tools "deflect" or bend under load, and anticipating this bend is what it is all about. Sharp tools deflect less than dull tools, but with each pass the tool gets a little duller and the deflection becomes greater. If you try to machine a long shaft with a small diameter, the center will always have a larger diameter than the ends, because the part deflects away from the tool where it has less support. You can go crazy trying to machine it straight, or you can simply pick up a good, flat mill file and file it straight in a few moments. Machine tools will never replace the "craftsman's touch," and machining is a combination of both good tools and good technique.

You Don't Become a Machinist by Buying a Machine

You should strive from the beginning to make better and more accurate parts than you think you need. Work to closer tolerances than the job demands. Be on the lookout for ways to make a job easier or better. Having a selection of appropriate materials on hand and a good cutoff saw to get them to rough size is a good start. Take some time and read through this instruction book before you try machining anything. We want you to enjoy the process of creating accurate parts from raw metal. Buying a machine didn't make you a machinist, but using it along with the skill and knowledge you acquire along the way eventually will. With the purchase of Sherline equipment, you have taken your first step toward many years of machining satisfaction. We thank you for letting us be a part of that.

Thank you,
Sherline Products Inc.

SHERLINE FACTORY TOURS

Visit Sherline's factory in North San Diego County and see miniature machine tools being produced. If you can't come by, see the photo factory tour on our website at sherline.com/about/factory-tour/.

General Precautions

- **DO NOT** attempt to operate the lathe or mill without first mounting them to a secure base. (See page 10.)
- **DO NOT** turn on the motor with a 3-jaw chuck mounted if the jaws are not tightened on themselves or on a part. The acceleration of the spindle can cause the scroll to open the chuck jaws if not tightened.
- **DO NOT** lift or carry the machine by the motor. The cast motor mount was not designed to support the entire weight of the machine. Carry the machine by lifting under the base

or by the mounting board. It is also advisable to remove the headstock/motor/speed control unit when transporting the machine. The inertia of a sudden shock can also over stress the motor mount.

- A chip guard (P/N 4360) is now available that offers additional protection from flying chips when working near the spindle. It is not a substitute for wearing proper eye protection, but it does offer additional safety. It will also contain cutting oil to help keep your work area cleaner.

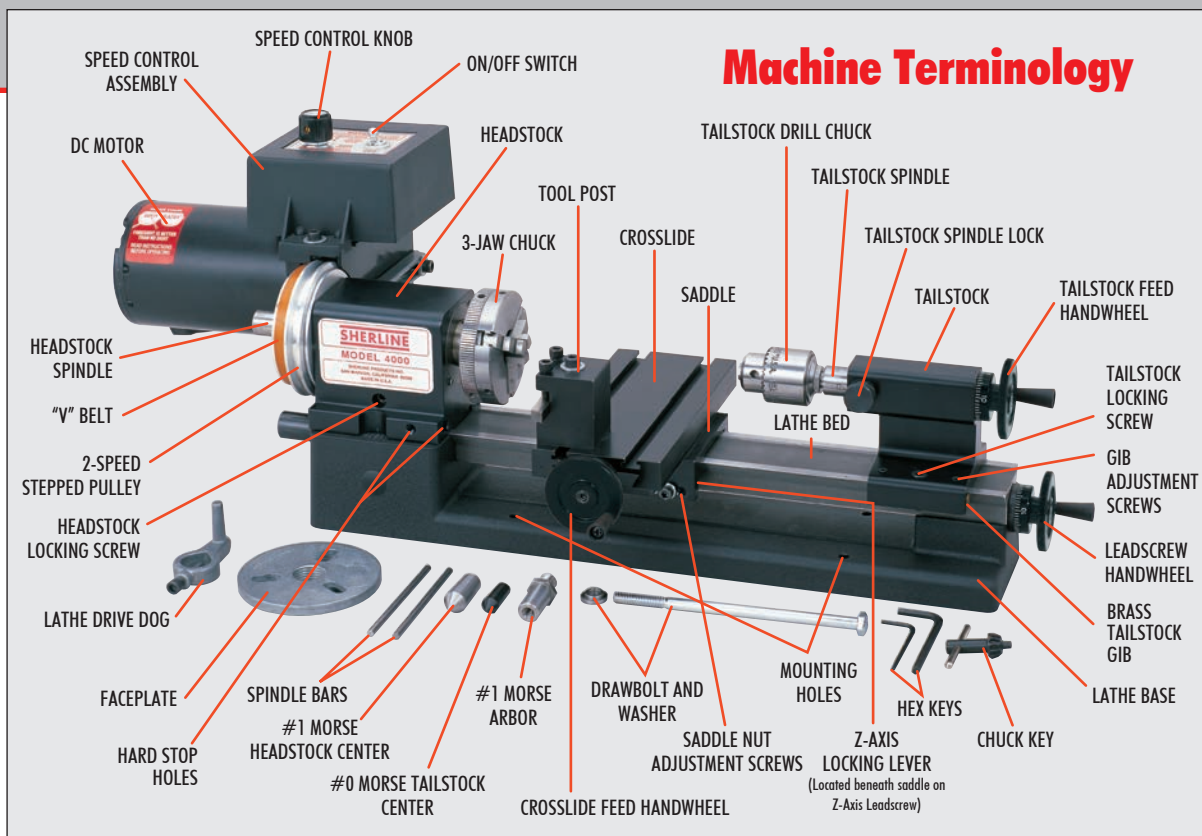

FIGURE 2—Lathe part terminology

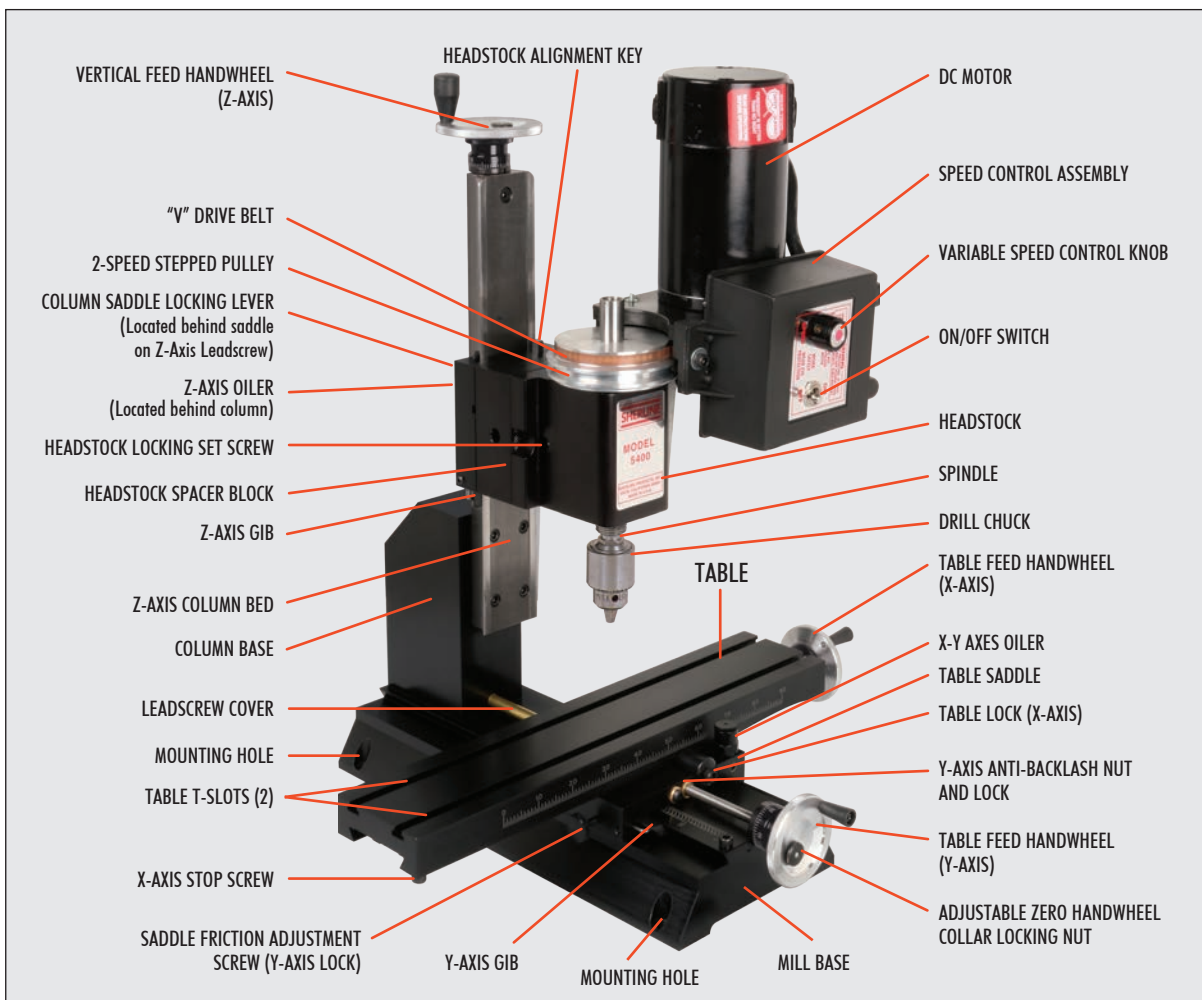

FIGURE 3—Milling machine part terminology

WARNING! WD-40 is a rust preventative, not a lubricant. Do not use WD-40 on your machine slides or screws as a lubricant.

Avoid Overtightening!

One of the problems with designing and manufacturing metal cutting equipment of this size is that the operator can physically be stronger than the machine, which is not normally the case with larger tools. For example, a 10-pound force applied a couple of inches out on a hex key becomes a 650-pound force at the tip of the screw. If you tighten both screws on the tool post this tight, it becomes approximately 1300 pounds of force on relatively small parts! Tools and/or parts can become distorted and accuracy will be lost. **Overtightening hold-down screws and T-nuts in their slots can distort the crosslide or mill table.** It is not necessary to overtighten parts and tools, because loads are smaller on equipment of this size. Save your equipment and increase accuracy by not overtightening and by taking light cuts.

Don't Over stress the Motor!

It is also important to realize that you can overload the motor supplied with this lathe or mill. * The many variables involved in machining, such as materials being machined, size of cutter, shape of cutter, diameter of stock, etc., can leave but one rule to follow...**COMMON SENSE!**

*The motor is thermally protected, so if it is overloaded, it will simply shut down until it cools. See note on thermal protection in the *motor/speed control* section on page 10.

CAUTION!

Read all operating instructions and safety rules carefully before attempting any machining operations.

The Customer's Responsibility

Always use care when operating the lathe and mill. Follow the safety rules for power tools on page 2. Turn off the motor

Lubrication

Machine Slides—Use a light oil such as sewing machine or 3-in-1 oil or grease on all points where there is sliding contact. This should be done immediately after each cleanup. We grease the slides at the factory to ensure the lubrication stays in place during shipping, but light oil will work fine once you begin using the machine. Do NOT use WD-40 for lubrication!

Leadscrew, Tailstock Feed Screw, Crosslide Screw—Light oil should be placed along all threads regularly. At the same time, check that the threads are free from any metal chips. Use an air hose or inexpensive paint brush to keep them clean. All Sherline mills now include oil reservoirs on the X/Y axes and the Z axis to help keep critical parts lubricated. Another new feature is the brass leadscrew cover that keeps chips off the rear of the Y-axis leadscrew.

Tailstock Screw—Wind out the spindle as far as it will go and oil it with light oil.

Handwheels—A few drops of light oil or a little grease behind the handwheel will reduce friction between the surfaces and make operation easier and smoother.

Headstock Bearings—These bearings are lubricated at the factory for the lifetime of the machine and should not need further lubrication. DO NOT break the seals.

Spindle Motor—Sealed ball bearings require no maintenance.

When NOT to lubricate certain surfaces

The mating surfaces of the arm, the column and the column cap on the Model 2000 mill are to be kept free from lubrication.

before attempting adjustments or maintenance. (Do not simply turn the speed control down to zero RPM but leave the motor switch on.) Be sure the work piece is firmly supported on the lathe or mill. Accessories should be mounted and operated following instructions carefully. Keep your machine clean, lubricated and adjusted as instructed. Do not leave cleaning rags, tools or other materials on the lathe bed or around moving parts of the machine.

Learning More About Machining

Many fine books have been written on machining techniques and are available at your local library or bookstore. Although these books often refer to machines many times larger than Sherline's tools, the principle remains the same. Sherline offers several good books related specifically to miniature machining. Visit sherline.com/books/ for more information.

Visit the Sherline Website for the Latest Updates

A world of up-to-date information on Sherline tools and accessories, and their use is available at sherline.com.

Here are a few key addresses (type sherline.com/ and then add the following file names after the “/” symbol):

Accessory instruction links:	product-information/sherline-accessory-instructions/
Video instruction links:	sherline-videos/
Links to interesting sites:	related-links-and-resources/
Projects by Sherline machinists:	workshop/
Price lists:	sherline-price-lists/
Reference dimensions of Sherline tools:	standard-dimensions-of-sherline-tools/
Sources for raw materials:	raw-materials/
Tips from Sherline machinists:	tips/
Sherline photo factory tour:	about/factory-tour/
Special instructions and help sheets:	product-information/sherline-accessory-instructions/help-sheets-and-instructions/
Information on CNC:	cnc-links-and-resources/

Tightening the column bolt causes friction between these surfaces to resist movement of the arm during the forces and vibration of machining. If these smooth surfaces are lubricated, the arm or the column could move during machining even if the bolt is securely tightened. Clean these surfaces periodically with mild detergent or bathroom spray cleaner to keep a good “bite” between surfaces. The same goes for the surfaces between the “knuckle” and the ends of the swing arm. These surfaces are smooth enough that adjustment is easily accomplished with the nut loosened even without lubrication. They should be free of dirt and chips, but please resist your natural inclination to lubricate them, as they do their intended job better when dry.

A Note on Synthetic Greases

Several years ago we started using a Teflon-based (PTFE) synthetic grease to lubricate not only the Sherline tools we sell, but also the factory machines that we use to produce them. This clear, non-staining grease can be found in most auto part stores, and it is also available from Sherline as an accessory in either tube or spray canister form. It offers smoother action than conventional grease when used on sliding parts, and we highly recommend it.

Initial Assembly of a New Machine

Your new lathe or mill will come packed in a box with some items disassembled for shipping purposes. This has been done to minimize the chance of damage during shipping. On the lathe, you will install the crosslide table onto the saddle. On the mill you will install the Z-axis column onto the base. On some mills you will reinstall the X-axis handwheel. On

both machines you will need to install the motor and speed control. Some of these parts are assembled and tested for fit at the factory prior to shipping. They are then disassembled and packaged, so everything should go together easily when you reassemble it. The motors are “run in” for approximately one hour to assure proper function and seating of the brushes. Before you call us and say a part is missing, please look carefully through the packaging. Some parts are in bags taped to the bottom of cardboard flaps or spacers, and you may not notice them when you open the box and remove the major components.

LATHE—Mounting the Crosslide

Installation of the crossslide requires no tools. It is located under a flap of cardboard that retains the lathe base in the shipping box. First, make sure the bottom of the crossslide has a light coat of grease on all the sliding surfaces. This will have been applied at the factory, just make sure it has not been wiped off and that it is evenly distributed.

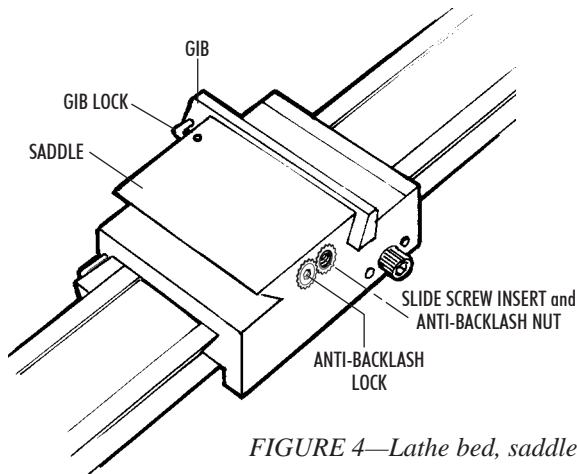

FIGURE 4—Lathe bed, saddle, and gib

Next, see that the gib is in the proper position on the saddle. (See Figure 4.) It is taped into position for shipping. Remove the tape holding it in place. If the gib has come off, reposition it on the gib lock as shown.

From the front of the lathe, engage the crossslide dovetail with the gib and matching dovetail on the saddle. Slide it onto the saddle about 1/4" (6-7 mm) until it stops. (See Figure 5.)

Look underneath and align the slide screw with the threads on the brass slide screw insert on the side of the saddle. (See Figure 6.) Turn the crossslide handwheel clockwise to engage the threads. Continue to crank the handwheel clockwise until the crossslide is in the desired position on the saddle.

All MILLS—X-Axis Handwheel Installation

Mills with adjustable “zero” handwheels come with the X-axis handwheel removed to prevent damage to the leadscrew during shipping. Reinstalling the handwheel is a simple process:

1. Loosen the X-axis table lock (the barrel-shaped lock on the saddle that is tightened against the side of the mill table with a socket head cap screw). From the end of the mill table where the X-axis leadscrew protrudes, push on the end of the mill table to make sure it seats tightly against the leadscrew.
2. Examine the red collar on the handwheel to see that the small hole is aligned with the head of the set screw. If it is not, loosen the black locking nut on the handwheel and rotate the collar until you can see the head of the set screw.

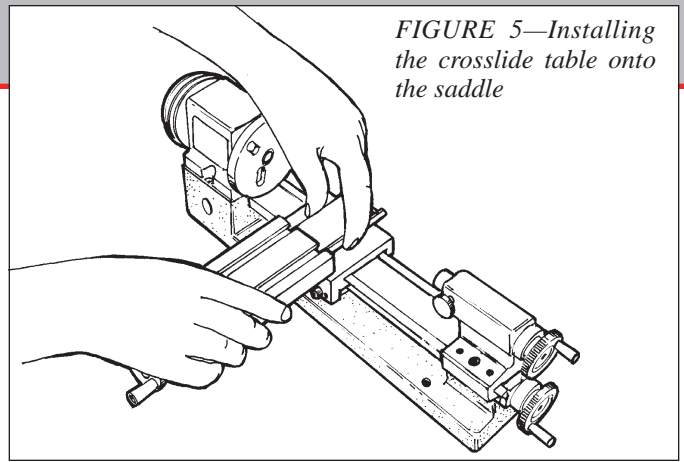

FIGURE 5—Installing the crossslide table onto the saddle

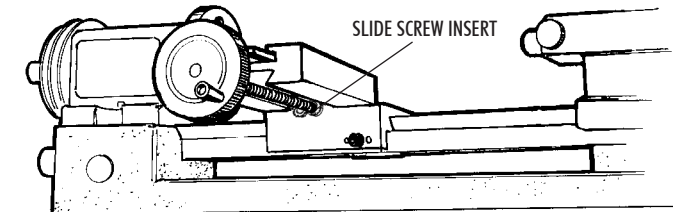

FIGURE 6—Aligning the slide screw with the brass slide screw insert

3. The handwheel was installed at the factory and then removed for shipping. You should be able to see a mark on the leadscrew where the set screw was previously tightened. When reinstalling the handwheel, try to have the set screw pick up this same position on the leadscrew.
4. Slide the handwheel onto the end of the leadscrew shaft and push until the handwheel is fully seated and the thrust collar is clamped tightly between the handwheel and the leadscrew collar. A 3/32" hex wrench is included with your machine to tighten the handwheel set screw.

Digital Readout Handwheels

If you ordered your mill equipped with a digital readout, the X-axis handwheel will again be removed to prevent damage during shipping. The proper thrust collar has been factory installed. If a 1/4" shim washer is required, it will be included in this package. Place it on the leadscrew shaft before installing the handwheel. Follow the installation instructions included with the P/N 8100 digital readout to install the encoder housing and handwheel unit.

5000-Series Mills—Mounting the Column

The mill is shipped attached to a piece of plywood to keep it from moving in the box. Before you begin, remove the screws holding the mill base to the plywood. It was installed strictly for packing purposes and will need to be removed so that the column can be installed. The Z-axis column is mounted to the base with two 1-3/4" long, 1/4-20 socket head screws. These screws and the hex key tool you will need to tighten them are packaged in the bag with the motor mounting bracket and drive belt. It is much easier to mount the column to the base before you mount the motor and speed control to the saddle. Set the column on the base aligned with the mounting holes and hold it in position while you insert the first screw up from the

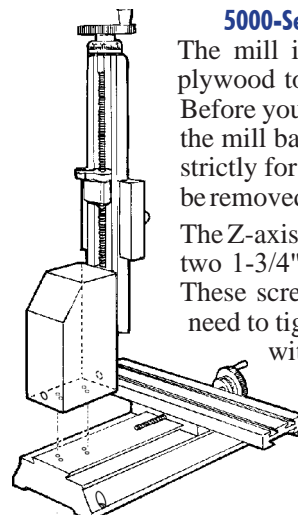

FIGURE 7—Mounting the 5000-series mill Z-axis column

bottom of the base. Hand-turn the first screw part way in, and then start the second screw. This can be done with the machine upright by letting the base hang over the edge of your table or bench just far enough to expose the first hole. Using the large 3/16" hex key provided, snug up both screws lightly first, and then tighten evenly.

2000- and 5800-Series Mills—Assembling and Mounting the Multi-Direction Column

To assemble the multi-direction column, make reference to the exploded view on pages 49 through 52 of these instructions and complete the steps that follow:

1. Attach the round column base (P/N 56700) to the mill base with the two 1/4-20 x 1-1/2" socket head cap screws.
2. Screw the arm hold-down bolt (P/N 56130) into the top of the round column base and tighten with an adjustable wrench using the two flat indentations on the shaft.
3. Slip the round column top (P/N 56550) over the pin and rotate it until the flat sides are parallel to the mill base and the engraved degree lines are on the same side as the X-axis handwheel.
4. Using an 11/16" or a 17 mm wrench, loosen the flange nut holding the bed and swing arm together. Rotate the bed away from the swing arm until they are at approximately a 90° angle to each other. Retighten the flange nut firmly to hold the column in this position. Discard the protective wood spacer that was installed between the bed and arm during shipping.
5. Set the swing arm over the column and align it approximately square with the mill base and in about the center of its travel. Make sure the swing arm registers on the flats of the column top and is properly seated. While still holding the swing arm unit in place, set the hold-down washer (P/N 56200) over the end of the bolt. Put a flange nut on the end of the bolt and tighten it against the hold-down washer firmly to lock the swing arm in place. **NOTE:** There should be NO lubrication on the mating surfaces between the arm and the column base. Friction between these surfaces keeps the arm from moving during cuts.
6. Place the column adjustment block (P/N 56350) on top of the swing arm and attach it with two 10-32 x 5/8" socket head cap screws at both ends. Adjust the 1" long center bolt so that it is just touching the flat in the bottom of the relieved section in the top of the pivot knuckle when the column is in the 90° position.

NOTE: If you remove the column adjustment block to accommodate a backward tilt movement of the column, make sure you replace it when returning the column to an upright position. It not only serves as a reference point when returning the column to the 90° position, it also keeps it from accidentally swinging down and damaging the table if the flange nut is loosened.

7. Slip the alignment key into its keyway in the mill saddle. Place the assembled headstock/motor/speed control unit (See next section) over the pin on the mill saddle and over the alignment key. Tighten the set screw in the side of the headstock to hold the entire unit in place. Recheck to be sure you have tightened the flange nut on the shouldered bolt pivot pin (56210) securely so that all the weight of the column is not resting on the column adjustment block bolt.

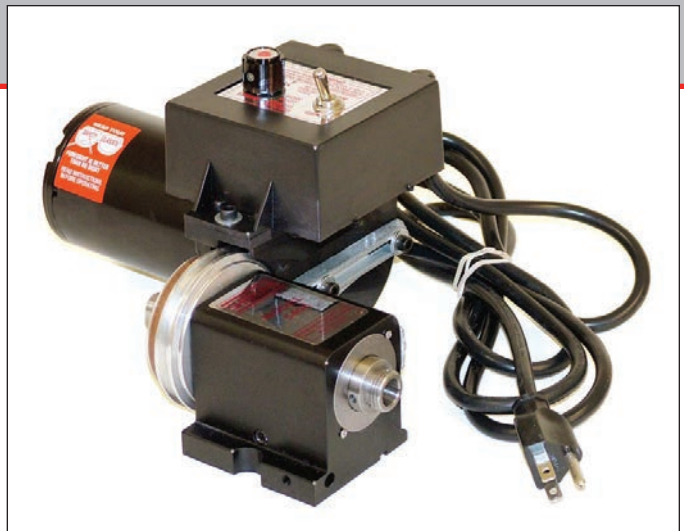

FIGURE 8—The assembled power unit.

Mounting the Motor and Speed Control Unit to the Headstock

(Refer to Figure 13 on the following page, and the exploded views on pages 45 through 52 for part number references.)

In order to keep shipping costs and damage to a minimum, all new Sherline machines are shipped with the motor and speed control disassembled. The same power unit assembly is used on all Sherline lathes or mills, so these instructions apply to all machines (Video instructions available on sherline.com).

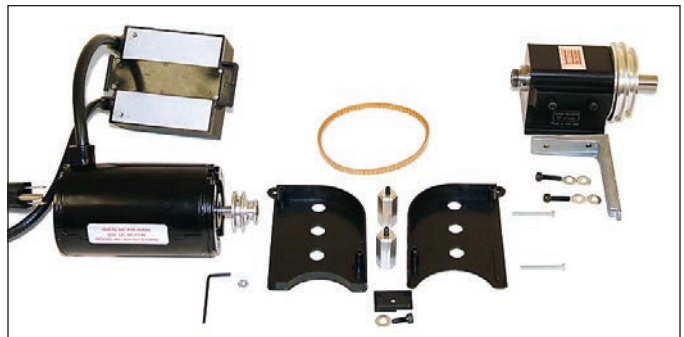

FIGURE 9—Components ready for assembly.

Assembly Procedure

Gather all the needed components as shown in Figure 9 above. Assemble them as follows:

1. Using the small hex key, remove the motor pulley from the motor shaft by loosening its set screw. Place the inner belt guard against the motor and secure it using the two hex aluminum standoffs (P/N 43100). There are four threaded holes in the motor. Use the pair that aligns with the brush housings so the cord to the speed control housing points downward as shown. (See Figure 10.) Reinstall the motor pulley (P/N 43360) to the motor shaft and tighten the set screw, making sure it engages the flat on the motor shaft. The end of the pulley should be even with the end of the motor shaft with the smaller pulley toward the outer end of the shaft.
2. Place the drive belt over motor pulley. (See Figure 10 on next page.)
3. Make sure the drive belt is routed properly. Then set the outer belt guard in place on the inner belt guard, locating the holes in outer belt guard over the ends of the motor standoffs.



FIGURE 10—Place belt over motor pulley.

Press the two nuts into the hex shaped depressions in the rear of the inner belt guard and secure the outer cover with two 1-3/8" pan head screws through the covers and into the nuts. Don't fully tighten until everything is aligned.



FIGURE 11—Attach outer belt guard.

4. On top of one end of the two belt guard halves you will see two "ears" with holes in them. These are where the speed control housing pivots. On the plate on the bottom of the speed control housing are two pins that go into these holes. Put the pin closest to the motor in place, then bend the other "ear" away from the motor far enough that you can engage the other pin so the cover pivots on these

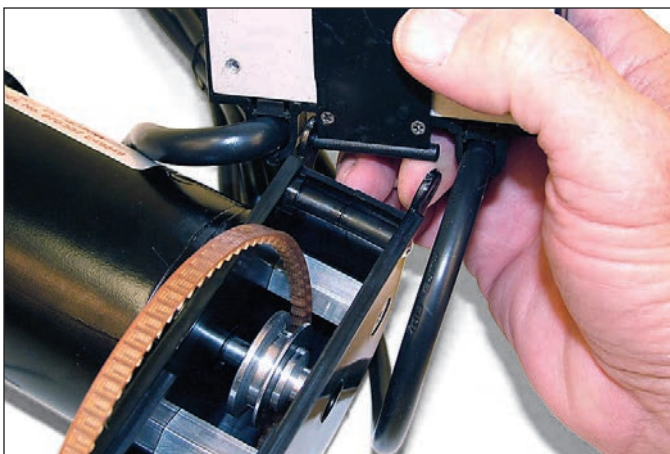

FIGURE 12—Insert "ears" of speed control housing into holes in belt guard tabs.

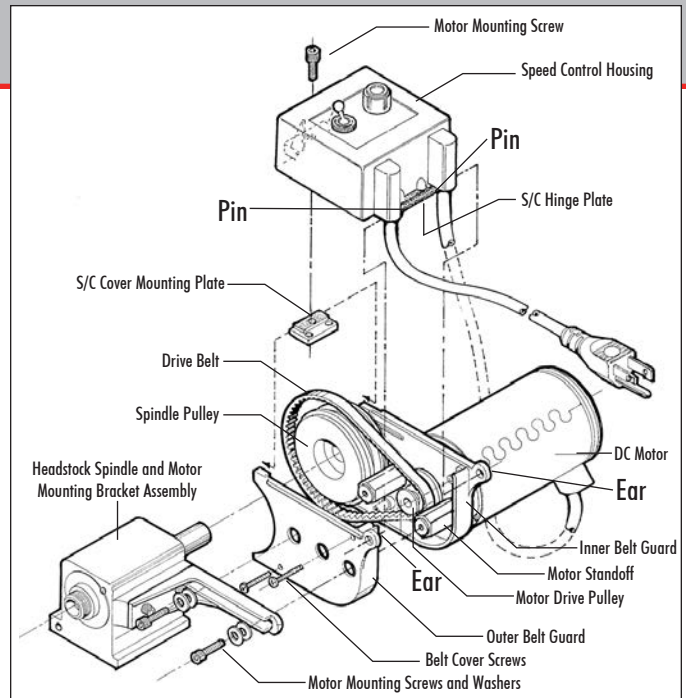

FIGURE 13—DC motor and speed control assembly.

pins. The plastic is flexible enough so that you can do this easily and it will spring back into position.

5. Attach the motor mounting bracket to the rear of the headstock with two 10-32 x 7/16" socket head screws. These screws are shipped threaded into the headstock rather than in the parts bag. There is enough "play" in the mounting holes to allow the motor to be adjusted so it is parallel with the spindle axis. (NOTE: If a chip guard is to be mounted, its attachment screw replaces one of these mounting screws. It can be mounted at this time or after the headstock is in place. See instructions that come with the chip guard.)
6. Place the drive belt over the spindle pulley and insert the two 10-32 x 3/4" socket head screws (with 2 washers on each) through the motor mount slot and into holes in the ends of the motor standoffs which are exposed through locating holes in the outer belt guard. The normal operating position for the drive belt is on the large diameter groove on the motor pulley and the small diameter groove on the spindle pulley. Use of the other (high torque) position is discussed elsewhere in the instruction manual.

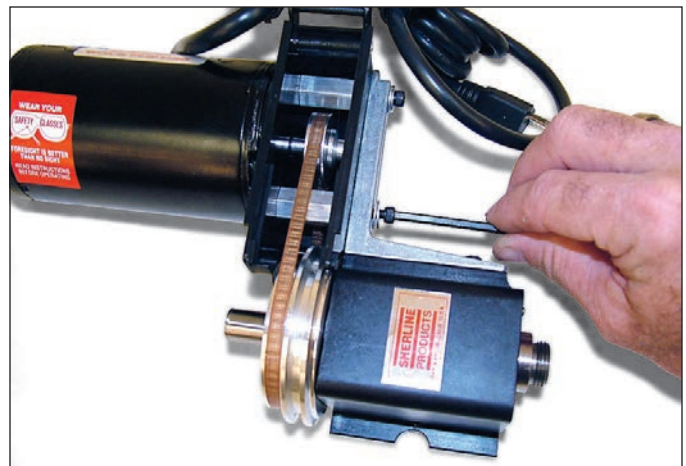

FIGURE 14—Attach motor to motor bracket.

7. Temporarily tighten the two motor mount screws. Pivot the speed control unit up and out of the way to check the alignment of the drive belt. It should be perpendicular to the drive pulleys. If not, loosen the set screw on the motor pulley and adjust it in or out on its shaft until the drive belt is square with the motor.
8. Loosen the two motor mounting screws and push the motor away from the headstock to adjust tension in the drive belt. Tighten the mounting screws once again to hold the motor/speed control unit in place. (**NOTE:** Do not over-tension the drive belt. Just make sure it has enough tension to drive the spindle pulley without slipping under normal load. By not over-tightening the belt you will not only extend its life, but will also provide a margin of safety for belt slippage should a tool jam in a part or an accident occur. The belt must be a little tighter when used in the high torque pulley range because small diameter pulleys are not as efficient.)
9. Set the cover mounting plate into the top of the belt guard housing so it rests on the rails molded onto the inside surfaces of the housing. (The pressed-in nut in the mounting plate goes down and toward the outside.) Slide the plate toward the outside (toward the spindle pulley) until it stops. (**NOTE:** The mounting plate is removable to allow easy changing of the drive belt position.)

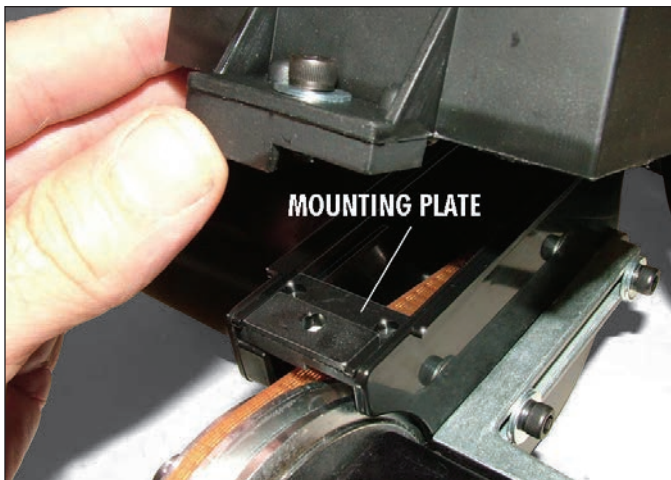

FIGURE 15—Insert mounting plate between belt guard halves and secure speed control housing to nut in plate.

10. Rotate the speed control housing down into place and insert the single 10-32 x 1/2" socket head screw through the hole in the speed control housing and into the nut in the mounting plate. Tighten it enough to hold the housing in place, but do not over-tighten.
11. Make sure the power switch is in the "OFF" position and the speed control knob is dialed all the way counter-clockwise to the lowest speed position. Plug in the motor, turn the On/Off switch to the "ON" position and slowly turn the speed control knob clockwise until the spindle starts to turn. Listen and watch the belt to make sure it is not rubbing on the belt guard or mounting tab near where it exits the belt guard. If it is, you may need to file off a little plastic until the belt does not rub. Turn the On/Off switch to "OFF," unplug the motor. Headstock unit is now ready to install on a lathe or milling machine.

Mounting the Headstock to the Lathe or Mill

You may notice that the post onto which the headstock mounts is a loose fit where it projects from the lathe bed or column saddle. This is normal, and the diagram in Figure 16 will help you understand how it works.

The screw in the front center of the headstock has a cone point. The pivot pin has a tapered slot with a corresponding angle. When the screw is tightened, its angled face engages the groove, and, because the pivot pin can not come up, it draws the headstock down into position, clamping it into place. If the pin were rigid, it could keep the headstock from pulling down squarely on the alignment key.

The headstock is aligned with the lathe bed or column saddle by means of a precision ground key that fits into keyways in both parts. It is not square in cross section so it will fit in only one direction. Push the headstock firmly against it as you tighten the hold-down screw. The mill column saddle has two keyways milled into it so the headstock can be mounted in conventional fashion or at a 90° angle for horizontal milling.

NOTE: Alignment keys are custom fitted to each machine. If you have more than one component that uses an alignment key, try to keep the key with the slot it was originally fitted to.

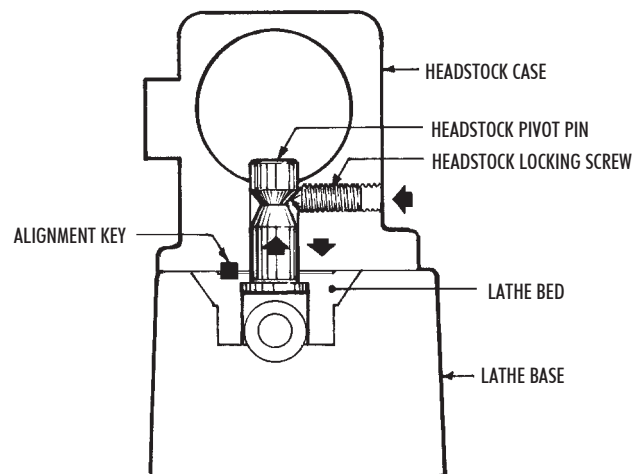

FIGURE 16—A cross-section of the headstock showing the pointed locking screw.

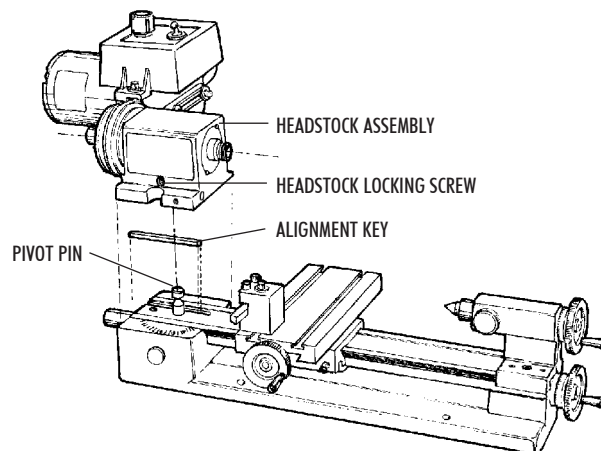

FIGURE 17—Headstock and alignment key in position over lathe.

CAUTION! Always make sure the key, slot and mating surfaces are free from dirt and chips before locking down the headstock.

Removing the headstock alignment key permits the headstock to be mounted in positions other than square. This allows you to mill parts at an angle or turn tapers on the lathe. When using the lathe or mill without the alignment key, keep cutting loads light.

Operation of the Motor and Electronic Speed Control

The motor is supplied with current from an electronic speed control that produces a comprehensive range of speeds suitable for all operations. Special circuitry designed into the DC motor speed control automatically compensates for speed changes due to increased load. If the spindle RPM drops noticeably when cutting, you are taking too heavy a cut. The speed range of the spindle using the speed control is from 70 to 2800 RPM in the normal belt position. This is achieved without the inconvenience of belt or gear ratio changes as is the case with other designs. A second belt position is offered as an additional feature to provide extra torque at low RPM for larger diameter parts should your job require it.

To operate the motor, turn the speed control knob counterclockwise as far as it will go. Then turn the toggle switch to "ON" and select the desired speed by turning the speed control knob clockwise.

The Advantages of Sherline's DC Motor and Electronic Speed Control
 Sherline's 90-volt DC motor is very smooth and powerful, particularly at low RPM. The specially designed electronics package also provides some unique advantages in addition to smooth speed control and a broad speed range. A special circuit compensates for load, helping to keep RPM constant. The machines can also be used on any electrical current worldwide from 100 to 240 VAC, 50 or 60 Hz without further adjustment other than seeing that the proper wall plug is used. The control reads the incoming AC current and automatically adjusts to output the proper DC current to the motor.

Motors are Pretested at the Factory

Your new motor should run smoothly the first time you use it, as it has been "run in" for about an hour before being shipped to you. Despite our secure packaging, there have been cases where extremely rough handling by a shipper has damaged the magnets in the motor. If the motor does not run when plugged in, turn the motor by hand. If it does not turn smoothly, it may have been damaged in shipment. Call Sherline for instructions on making a damage claim with the shipper. Do not attempt to repair the motor yourself.

CAUTION—Motor is Thermally Protected

Thermal protection means there is a built-in circuit breaker that will shut off the motor if it gets too hot. This keeps the motor from burning out. The breaker will automatically reset as soon as the motor cools, and you can go back to cutting, but you should be aware of how it works and what to do if the machine suddenly shuts itself off. If your motor is shutting down from overheating on a regular basis, it means you are taking cuts that are too heavy or operating at too high an RPM for long periods. Slow your speed down, reduce your cut or feed rate, and you should have no further problems.

Due to the nature of miniature machining, overloading the machine is a common problem. It is often tempting to try to speed up the process by working faster. Keep in mind this is a small machine, and work with patience and precision—don't be in a hurry. Your parts will come out better, and your machine will last much longer if it is not overstressed.

What to Do if the Motor Suddenly Shuts Down

If your thermal protection circuit shuts down the motor while work is in progress, immediately shut off the power switch and then back the tool out of the work. It should only take 10 seconds or less for the circuit breaker to reset. Then you can turn the motor on and start the cut again, this time putting a little less stress on the motor. If you leave the tool engaged in the part and the power on, when the circuit breaker kicks back on, the motor must start under load. This can be very hard on your motor.

Remember that the circuit breaker turns the speed control off, which turns off the motor. If power were to be applied to the speed control with the motor disconnected, it could damage the speed control.

Thermal protection is built into your motor to insure it is not damaged by overloading. Use good common sense when operating the motor for years of trouble-free operation.

Replacing Brushes on a DC Motor

Since 2002, Sherline has used DC motors with externally replaceable brushes. The brushes are removed by using a large, flat-bladed screwdriver to unscrew the brush covers which are located in round bosses on the sides of the motor near the rear. New brushes and springs are inserted and the covers replaced. Brushes should be replaced if they are chipped, worn unevenly or if they are less than 1/4" long. DC motors supplied before 2002 utilize a different brush replacement procedure. If you have the older style internal brushes, instructions for changing them can be found at sherline.com/Wordpress/wp-content/uploads/2016/01/dc_brush.pdf.

Mounting the Lathe or Mill to a Board for Stability

Mounting the lathe to a board is necessary because of the narrow base. This keeps the machine from tipping. We recommend mounting the lathe on a piece of finished shelf material, which is readily available at most hardware stores. (See Figure 18 for sizes.) The machine can be secured to the

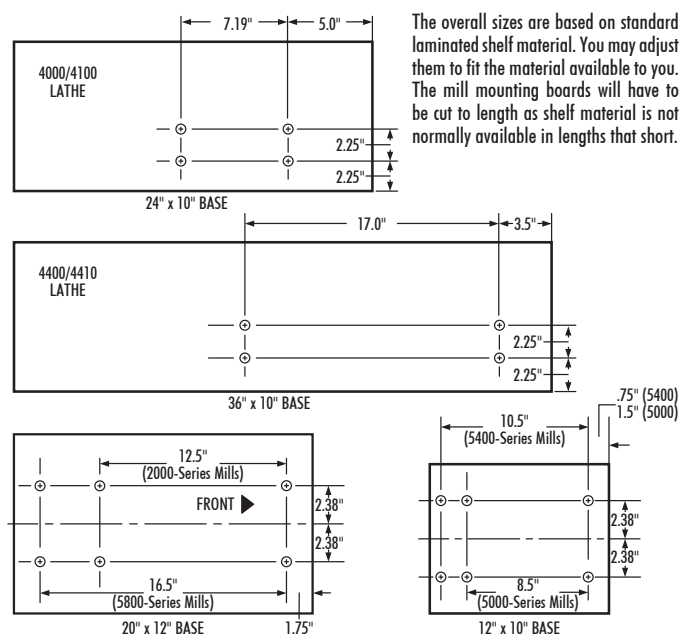

FIGURE 18—Plans for mounting board hole patterns. Confirm actual dimensions from your lathe or mill before drilling.

CAUTION! Check the Tightness of all Bolts—Vibration in shipping can cause some bolts or screws to loosen up. Before using your new machine, check the tightness of all fasteners. It is also a good idea to check tightness periodically when using the machine, as vibration from operation may cause some fasteners to loosen up.

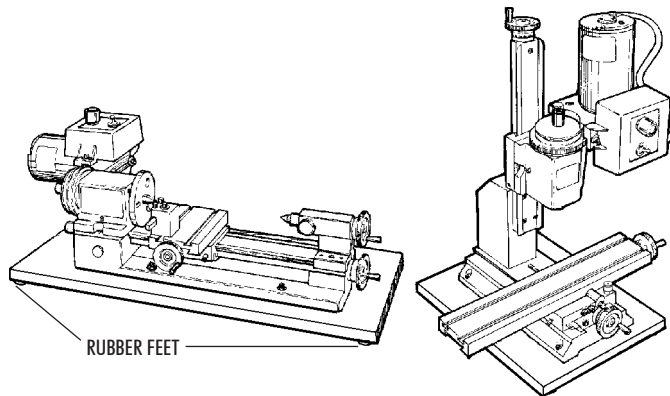

FIGURE 19—Machines mounted to a base board for stability.

board using four 10-32 screws with washers and nuts. Lengths should be 1-1/2" for short bed lathes and 1-7/8" for long bed lathes. Rubber feet should be attached at each corner on the bottom of the mounting boards. They are also readily available in hardware stores. This arrangement gives the machines a stable platform for operation yet still allows for easy storage. The rubber feet help minimize the noise and vibration from the motor. Mounting the tool directly to the workbench can cause vibration of the bench itself, which acts as a "speaker" and actually amplifies the motor noise. Bench mounting also eliminates one of the best features of Sherline machines...the ability to be easily put away for storage.

The mill may be mounted in a similar manner on a 10" x 12" to 12" x 20" finished shelf board with rubber feet using 10-32 x 1" screws to attach the mill to the board. You may want to drill clearance holes through the mill base board to access the column screws so the column can later be removed from the mill without removing the mill base from the mounting board.

REMEMBER: Do not lift your machine by the motor! Carry the machine by lifting under the base or by the mounting board. The cast motor bracket was not designed for lifting.

To keep your Sherline tools clean, soft plastic dust covers are available. The lathe cover is P/N 4150 for the Model 4000/4100 and 4500/4530 short bed lathes and P/N 4151 for the Model 4400/4410 long bed lathe. A mill dust cover is available as P/N 5150 for 5000-series mills and P/N 5151 for 2000-series 8-direction mills.

Converting Machines from Inch to Metric and Vice Versa

All Sherline tools and accessories are manufactured in your choice of inch or metric calibrations. Converting a lathe or mill from one measurement system to the other is possible, but it takes more than changing the handwheels. The leadscrews, nuts and inserts must also be changed. A look at the exploded views of the machines on pages 45 through 52 will show which parts need to be purchased. (Look for parts that have both a metric and inch version in the parts listing.) Conversion kits with all the necessary parts are available. If you are a good mechanic, you can do the conversion yourself, or you can return your machine to the factory for conversion.

ADJUSTMENTS

Two-Speed Pulley

The normal pulley position, which is placing the belt on the larger motor pulley and smaller headstock pulley, will suffice for most of your machining work. Moving the belt to the other

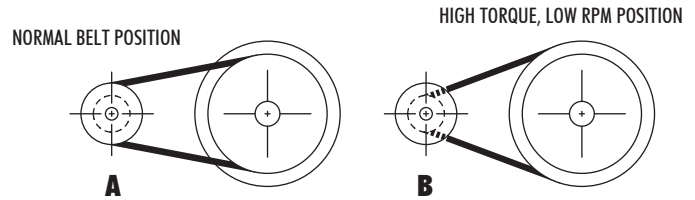

FIGURE 20—The two pulley positions. Position A is the conventional setting, position B offers more torque at low RPM when turning large diameter parts.

Approximate RPM range: A=70-2800, B=70-1280

position (smaller motor pulley, larger headstock pulley) will provide additional torque at lower RPM. It is particularly useful when turning larger diameter parts with the optional riser block in place. To change the pulley position, remove the speed control hold-down screw and pivot the speed control housing up out of the way. Remove the mounting plate from its position on the rails of the two halves of the belt guard housing. Loosen the two nuts that hold the motor to the motor mounting bracket and take the tension off the belt. With your finger, push the belt off the larger diameter groove of the pulley and into the smaller one. (Depending on which way you are changing it, this could be either the motor or spindle pulley.) Then move the belt to the larger diameter groove on the other pulley, and rotate the headstock by hand to get it to seat. Push the motor outward on the motor mounting bracket to put the proper tension on the belt, and retighten the two motor mounting screws. Now you can replace the mounting plate, pivot the speed control back down, and refasten it. Moving the belt back to the other position is simply a reverse of the above procedure.

Spindle Preload Adjustment

If any end play develops in the main spindle, it can be easily eliminated by re-adjusting the preload nut. (See part number 40160 in the exploded view.) When the headstock is assembled at the factory, the preload nut is adjusted to .0002" (.005 mm) of end play. This is controlled by the outer races of the bearing being held apart by the headstock case and the inner races being pulled together by the preload nut. This setting was determined through experience, and, like everything in engineering, it is a compromise. If the machine is only to be run at high-speed, this setting may be too "tight." The headstock will run fairly warm to the touch normally, but extended periods of high speed operation may bring about excessive temperature. The headstock should not become too hot to touch. If this is your case, the preload tension may need to be reduced slightly.

To change the adjustment, remove the spindle pulley, loosen the set screw in the preload nut and back the preload nut off 4° of rotation (counter-clockwise). The bearings are lightly pressed into the case, so the inner race will not move without a sharp tap with a plastic mallet to the end of the spindle where the pulley is attached.

If you find your bearings are set too loose, you may want to take up on the end play. You can check them with an indicator or by spinning the spindle without the motor belt engaged. If the spindle spins freely with a chuck or faceplate on it, the spindle is too loose for normal work. Adjust the preload nut until it turns only about one and a half revolutions when spun by hand.

Want to see some projects built by other Sherline machinists? Visit sherline.com/workshop/.

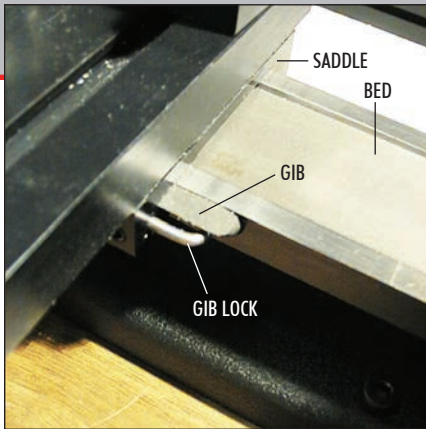

FIGURE 21—Adjusting the gibs

Gib Adjustment (Lathe and Mill)

(See Figure 21) Tapered gibs are fitted to the mill headstock, saddle and table and to the lathe saddle and crossslide. Correct adjustment of the gibs will ensure smooth and steady operation of the slides. The gib is

effectively a taper with an angle corresponding to the one machined into the saddle. It is held in place by an “L” wire gib lock that is secured with a locking screw. It is adjusted by loosening the gib locking screw and pushing the tapered gib inward until “play” is removed. After adjusting, retighten the locking screw. Milling operations require a tighter adjustment of the gibs than lathe operations.

Backlash Adjustment (Lathe and Mill)

Backlash is the amount the handwheel can be turned before the slide starts to move when changing directions. This is a fact of life on any machine tool, and on machines of this type it should be about .003" to .005" (.08 mm to .12 mm).

Backlash must be allowed for by feeding in one direction only. Example: You are turning a bar to .600" diameter. The bar now measures .622" which requires a cut of .011" to bring it to a finished diameter of .600". If the user inadvertently turns the handwheel .012" instead of .011", he couldn't reverse the handwheel just .001" to correct the error. The handwheel would have to be reversed for an amount greater than the backlash in the feed screw before resetting the handwheel to its proper position.

Backlash on the X- and Y-axes of the mill may be reduced to a minimum by adjustment on the anti-backlash nuts. These nuts are located on the handwheel ends of the mill saddle. The nuts are secured by button head screws that hold a star gear that interlocks with teeth on the nut.

To adjust backlash, simply loosen the button head screw that locks the star gear. Rotate the anti-backlash nut clockwise on the X-axis or counter-clockwise on the Y-axis until snug. Retighten the button head screw while pushing the gear toward the nut. With the anti-backlash nuts properly adjusted, the leadscrews should turn smoothly and have no more than the proper .003" to .005" of backlash.

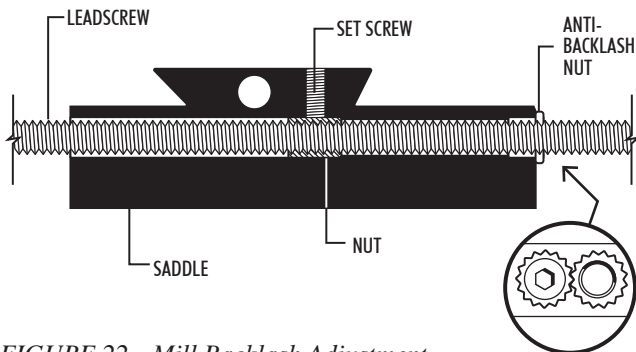

FIGURE 22—Mill Backlash Adjustment

NOTE: Older mills use a “pointer” type lock instead of the star gear.

Handwheel Adjustment (Lathe and Mill)

The handwheels are secured to their corresponding leadscrew shafts by a small set screw in the side of the handwheel base. Check them periodically to make sure they have not been loosened by vibration. On the adjustable “zero” handwheels, you must first release the rotating collar by loosening the locking wheel. Then rotate the collar until you can see the set screw through the small hole in the side of the collar and adjust the screw as necessary.

If a handwheel has been removed, when reinstalling it, make sure it is pushed up tightly against its thrust collar before tightening the set screw. Push the appropriate table or saddle toward the handwheel to remove any excess play before tightening. For the mill Z-axis, lift up on the headstock to remove play.

If excessive backlash develops at the handwheel and thrust collar junctions, adjust by first loosening the handwheel set screw. Index (rotate) the handwheel so the set screw tightens on a different part of the shaft. (If you don't, it may tend to keep picking up the previous tightening indentation and returning to the same spot.) Push the handwheel in tightly while holding the saddle and retighten the handwheel set screw.

Saddle Nut Adjustment (Lathe and Mill)

Both the lathe saddle and mill column saddle are connected to their respective leadscrews using a similar brass saddle nut (P/N 40170/41170 or 40177/41177). The saddle should first be positioned at the end of its travel as close to the handwheel as possible. A socket head cap screw attaches the saddle nut to the saddle, while two set screws align the nut to the leadscrew. Loosen the cap screw, bring each set screw into light contact with the saddle nut and retighten the cap screw. If binding occurs, readjust the set screws.

NOTE: The mill column saddle nut differs from the lathe leadscrew saddle nut in that it includes a spring-loaded ball that engages a detent in the saddle locking lever. See pages 17, 32 and 33 for details on use of the saddle locking lever.

Adjustment and Use of the Tailstock Gib

The brass tailstock gib should be adjusted so that it is equally tight at both ends and slides easily on the bed dovetail when the adjustment screw is loosened. As the brass gib wears, any play that develops can be adjusted out by loosening the two set screws, readjusting the two button head screws and then re-locking the set screws. To lock the tailstock in place on the bed, tighten the center socket head cap screw. Do not overtighten.

(NOTE: Lathes made prior to 1999 do not have a tailstock gib adjustment. They are locked by means of a horizontal screw through a split in the tailstock case.)

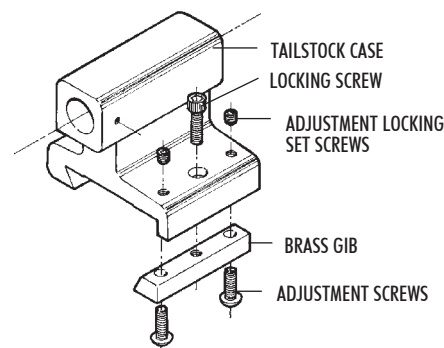

FIGURE 23—Components of the tailstock case and adjustable gib.

Aligning the Headstock and Tailstock on the Lathe

The versatile feature of Sherline machines that allows the headstock to be removed or rotated for taper turning and angle milling keeps us from being able to lock the headstock in perfect alignment. Precision ground alignment keys and accurate adjustment at the factory, however, make the machines highly accurate. In standard form, alignment should be within .003" (.08 mm). This should be more than acceptable for most jobs you will attempt.

Only someone new to machining would talk about “perfect” alignment. Machinists speak instead in terms of “tolerances,” because no method of measurement is totally without error. We believe the tolerances of your machine are close enough for the work for which it was intended, however, for those searching for maximum accuracy, here are some tips for maximizing the accuracy of your machine.

Loosen the headstock, push it back evenly against the alignment key and retighten. This will maximize the accuracy of the factory setting. To achieve greater accuracy, you will have to be willing to sacrifice one of the better features of your lathe or mill; that is, its ability to turn tapers and mill angles in such a simple manner.

HEADSTOCK—If you choose total accuracy over versatility or need it for a particular job, proceed as follows. Remove the headstock and clean any oil from the alignment key and slot and from the area of contact between bed and headstock. Replace the headstock, pushing squarely against the key and retighten. Take a light test cut on a piece of 1/2" to 3/4" diameter by 3" long aluminum stock held in a 3-jaw chuck. Use a sharp-pointed tool to keep cutting loads low so as not to cause any deflection of the part. Measure the diameter of both machined ends. If there is a difference, the headstock is not perfectly square. Now, without removing the key, tap the headstock on the left front side (pulley end) if the part is larger at the outer end. Tap on the right front side (chuck end) if the part is larger at the inner end.) You are trying to rotate the headstock ever so slightly when viewed from the top until the machine cuts as straight as you can measure. There should be enough movement available without removing the key, as its factory placement is quite accurate.

Take another test cut and remeasure. Repeat this procedure until you have achieved the level of perfection you seek. Then stand the lathe on end with the alignment key pointing upward and put a few drops of LocTite® on the joint between key and headstock. Capillary action will draw the sealant in, and when it hardens, the key will be locked in place. We prefer this method to “pinning” the head with 1/8" dowel pins, because it offers you the option to change your mind. The headstock can be removed by prying with a screwdriver blade in the slot between the bottom of the headstock and the lathe bed to break the LocTite® loose should you wish to be able to rotate the headstock again.

TAILSTOCK—To maximize the machine’s tailstock alignment, first make sure that there are no chips caught in the dovetail of the bed and no chips or dents in the taper of your tailstock center. Now put a 6" long piece between centers and take a long, light test cut. Measurements at either end will tell you if you need to use an adjustable tailstock tool holder in the tailstock to achieve better tailstock alignment. We manufacture adjustable tailstock tool holders (P/N 1202, -03, -04, -06) and

an adjustable live center (P/N 1201) that can help you attain near perfect alignment at the tailstock should your job require it. Instructions for their use are included with each item.

Remember that unless you drill very small holes (less than 1/64") or turn a lot of long shafts, you are giving up a very useful feature to solve a problem which can usually be handled with a few passes of a good mill file. The inaccuracy inherent in any drill chuck is such that perfect machine alignment is meaningless unless you use adjustable tailstock tool holders.

Squaring up Your Mill

The following tips are taken from the Model 2000 mill instructions. Though the 8-direction mill is shown in the examples, the same procedures would be used for aligning the 5000-series, and 5800-series mills, or any mill for that matter.

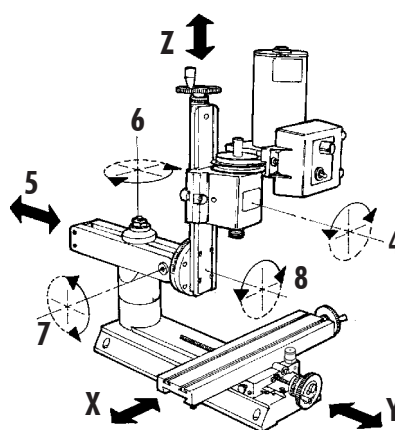

FIGURE 24—The axes of movement of a Sherline 8-direction mill. Table left/right movement is referred to as the X axis. Table in/out movement is the Y axis. Headstock up/down movement is referred to as the Z axis. The headstock can also be rotated on its saddle on Sherline mills (Shown as movement #4). Four additional column movements

available on the model 2000 mill are also illustrated here as numbers 5, 6, 7 and 8.

Determining the Level of Accuracy You Really Need

Squaring up a multi-direction mill can be a chore if you want “perfection.” It is best to determine how accurate the setup must be before you start. The larger a close tolerance part is the better the setup required. An error of .001" (.025 mm) per inch (25.4 mm) would be a very small error on a part .4" (10 mm) long. However, a part that is 5" long would have an error of .005". The type of machining that is going to be performed also has a bearing on the quality of the setup. As an example, a drilled hole doesn’t usually require the quality of setup that would be used for a bored hole, (assuming the hole is being bored for accuracy rather than for lack of a drill of the proper size). The amount of work that will be done with the setup should be considered too. If your setup is just to do one particular job you only have to set it up close enough to do that job. If the setup will accommodate future operations as well, it should be adjusted to the tolerances of the most critical job. For example, squaring up a mill and vise to work on a number of precise parts is worth more of your attention than setting up to drill one clearance hole in a non-critical part.

Limitations of the Production Process

Before starting you should realize that these mills are relatively inexpensive machine tools. They have accurately milled slides but the surfaces are not ground. To increase the accuracy of a Sherline tool only a percentage point would dramatically increase the price. We try to give a customer what we consider “the most bang for the buck.”

Why Aren't Alignment Pins Used to Square up the Machine?

If you are a novice to machining, you probably believe a machine should be designed so that a couple of pins could be dropped into holes, squaring up the machine and eliminating this whole alignment process. After all, that is the way they do it with woodworking tools. The truth is the tolerances that work well for wood cutting tools simply aren't accurate enough for most metalworking jobs. You just can't hold the tolerances required with "pins." When they fit tight enough to lock the head square to the table you can't remove them to do work that isn't square. They become more of a problem than the problem they were installed to eliminate. For example, an alignment or assembly error of .010" in a wooden kitchen table will never be noticed. Usually the floor it sits on is not even flat. It would be a waste of time and effort to make it more accurate than it has to be. On the other hand, a cylinder that has been bored out of square with the crankshaft in an automobile engine could wear the entire engine at an alarming rate. The piston can go up and down over a million times in a normal day's use. The additional cost in fuel and shortened life demands accuracy. Your Sherline mill should be adjusted and aligned to the degree of accuracy demanded by the particular job you are attempting to do.

Start by Getting the Column Close to Square with the Table

All Sherline Mills—The first place to start is to get the column approximately square with the table using the pointers and laser engraved scales on the machine. The first time you set it up you will have to use a machinist's square on the side-to-side column rotary adjustment as the pointer will not have been "zeroed in" yet. None of these adjustments must be extremely precise at this point because a finger type dial indicator will be used to make the final adjustments later. Remove the headstock/motor/speed control unit from the saddle. Place a machinist's square on the table and line up the front of the saddle to get the column approximately square front to back. Then line up on the right side of the saddle to get the column approximately square side to side. Reinstall the headstock assembly.

Check for Any Built-in Error in Your Machine

All Sherline Mills—(See Figure 25.) To check the built-in error of the machine use a dial indicator mounted in the spindle. Move the table under spindle with the Y-axis handwheel and note the error. This error will usually be around .001" to .002" (.05 mm) in 3" (76 mm). (Remember, the components are not precision ground, they are precision milled.) When squaring the head later on this error should be accounted for. Remember you are squaring the head and spindle to the base of the machine where the saddle travels, not the surface of the table itself. The head doesn't have to be square for this operation as long as you don't rotate the spindle since you are only checking for square in one direction.

Squaring up the Column

Model 2000- and 5800-Series Mills—(See Figure 26.) The next decision to make is where the spindle is to be located. With all the adjustments that can be made with the 8-direction mill you'll probably start with the spindle located near the middle of the X/Y table movements. Something that isn't too obvious should be considered now. If the ram (the two-bar slide that allows you to move the head in or out and left or right) isn't square with the X-axis, the rotating column calibrations will have an error. To square up the ram, mount a dial indicator to the worktable and move the X-axis back and forth while

FIGURE 25—Checking for built in error in the table travel along the Y-axis

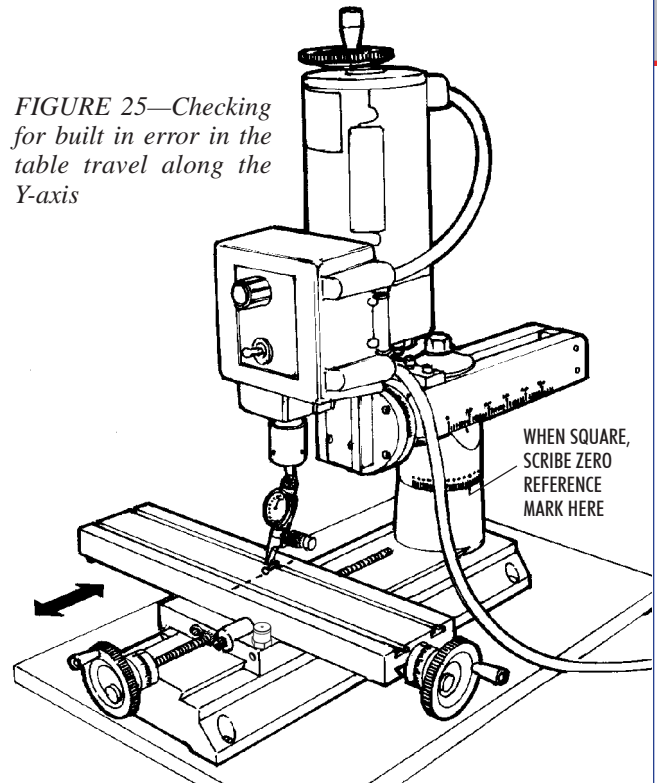

reading the left and right surfaces of the column bed near the bottom. This only has to be done if you will be rotating the column and want to be able to rely on the angle graduation readings. Once set, lock the ram in place with the flange nut. Now you can scribe a line on the column base opposite the "zero" mark for future reference as shown in Figure 25. We can't engrave this mark at the factory. For perfect accuracy, it must be done after each machine is aligned.

Model 5000-Series Mills—Though the column ram does not rotate on the 5000-series mills, its squareness can still be checked in the same manner if desired. The factory alignment of the holes is quite accurate, but a small amount of adjustment is available by loosening the two screws that hold the column base to the bed and pressing the base to one side or the other while retightening.

Squaring the Column with the X-Axis

Model 2000-Series Mills, Model 5800-Series Mills, OR 5000-Series Mills with Optional Rotary Column Attachment—(See Figure 27.)

The column should next be squared with the X-axis. This is accomplished with an indicator mounted in the spindle. Have the four socket head cap screws used to clamp the column rotation tight enough to keep the column from rotating, but not so tight that you can't move it with a light tap from a plastic mallet to the column bed. Because the axis that allows you to tilt the column in and out hasn't been squared yet you should only read the indicator at the same Y-axis location on the worktable that you used before. Offset the indicator at an angle in the spindle so that when the spindle is rotated it describes about a 2" to 3" circle on the table. Take readings at the extreme left and right positions. Adjust the column with light taps until there is little difference in the readings at either extreme. Don't try to get it perfect yet, just close enough so there isn't a gross error.

Hint: To keep the tip of the indicator from falling into the T-slots, some machinists keep a large ball bearing on hand. The two surfaces of a precision bearing are generally parallel. The bearing is placed on the mill table centered on the spindle

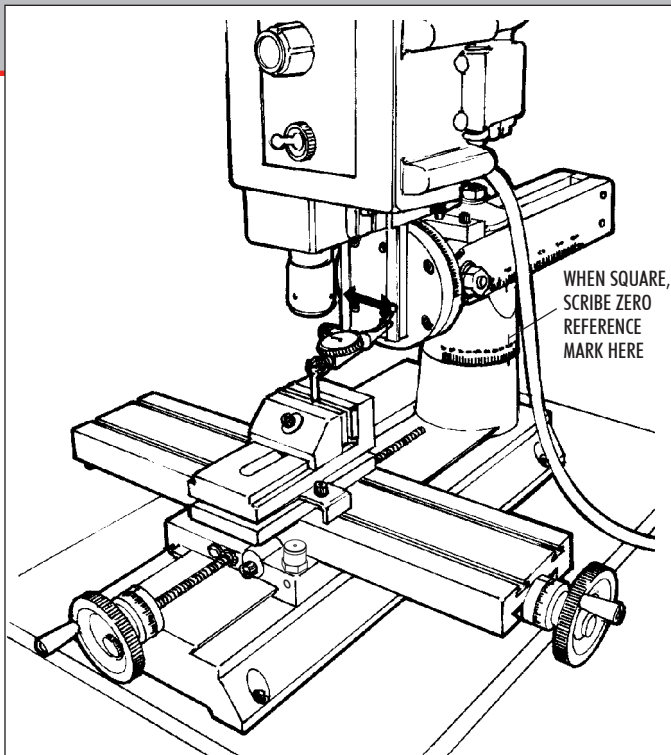

FIGURE 26—Squaring up the ram parallel to the Y-axis on the 2000-series mill. The indicator can be held with a chuck on the table or a mill vise as shown here. When square, tighten the nut on top of the column. 5000/5400-series mills can be adjusted slightly by loosening the two bolts that hold the column base in place, twisting the column slightly and retightening the bolts.

and the indicator is run around the surface of the bearing race, which provides a round, flat, parallel surface for the tip of the indicator to run against.

Model 5000-Series Mills—This axis is not adjustable on the 5000-series mills, but it can be checked in the same manner. Again, factory alignment should be quite good, but a slight amount of adjustment can be obtained by loosening the four screws that hold the column to the base and pressing the column to one side or the other while retightening.

Squaring the Column with the Y-Axis

Model 2000- and 5800-Series Mills—(See Figure 28.) Loosen the flange nut on the horizontal pivot pin just enough so that the column can be moved using the adjustment screw in the alignment block but there is no slop in the assembly. The tilt is harder to set because the spindle doesn't rotate at the pivot point, but once you understand this, the task becomes simpler. This is explained in the example that follows. The alignment block adjustment screw helps make fine adjustments in this direction easy. With the block in place and the flange nut loose, the entire assembly is kept from falling forward by the adjusting screw. This block can be left in place unless the ram is completely retracted or the column is tilted back at an angle that interferes with the block. With the indicator still held in the spindle, take readings parallel with the Y-axis near the front and rear edges of the table. Raise or lower the column with the alignment block adjusting screw until the readings are the same front and rear. Remember the location of the pivot point as you take these measurements and allow for it. (See following example in next column.)

Model 5000-Series Mills—This axis is not adjustable on the 5000-series mills, but it can be checked in the same manner. Again, factory alignment should be quite good, but a slight

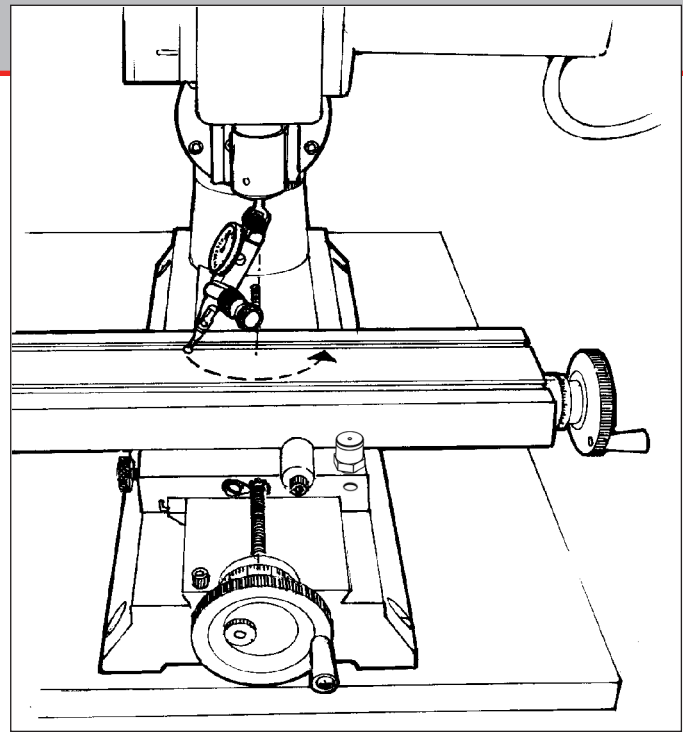

FIGURE 27—Squaring the left to right rotation of the column with the X-axis.

amount of adjustment can be obtained by loosening the two screws that hold the column to the base and shimming the column at the front or back with thin metal shim stock* as needed. Recheck your X-axis alignment after shimming.

**Hint: Shim stock can be purchased from most tooling supply catalogs. If you don't have metal shim stock available, cigarette paper or business card stock can be used as a temporary substitute depending on thickness needed.*

Example:

If the indicator reading is larger at the front of the table than the back, that means the column must be tilted back. Say your reading is "0" at the back and .010" (.25 mm) at the front. If you tipped the column back until the indicator read zero at the front, the reading at the back would not remain at "0" but would now be a negative reading. This is caused because the pivot point is located far enough behind the spindle so that both front and rear measuring points are still in front of it. Swinging the column back actually raises both points. The front point raises more than the back point, but both do go up. You will have to keep tilting the column back and measuring until you get the same reading front and back. This may require more movement than you first thought based on the difference between the initial measurements.

Fine Tuning the Headstock Alignment

All Sherline Mills—It is time to make the final adjustments to the rotating column, but first we'll add a little more confusion to your life. Remember it was mentioned that alignment pins are somewhat useless to line up a machine? Well, as much as we hate to admit it, in a sense we already have one. It is the alignment key that holds the headstock assembly square to the column saddle, which is mounted on the column bed. Removal of this key is what allows you to pivot the headstock on Sherline lathes and mills. It is one of the features that make our machines easy to use, versatile and very adaptable. It is also another thing you have to consider when searching for "perfect" alignment. If you have more than one key, try not to mix them up because they are matched during assembly to

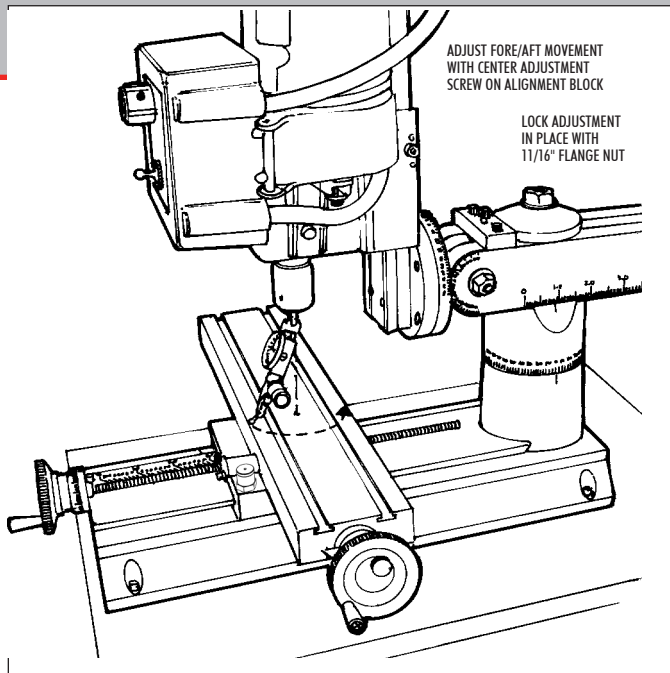

FIGURE 28—Squaring the fore and aft pivot movement of the column with the Y-axis. (See the hint in the section on squaring the X-axis above for a way to keep the tip of the indicator from dropping into the T-slots.)

fit as closely as possible. We have found the best way to deal with this potential problem is to push the head square against the key before tightening the cone point screw that locks the headstock in place. If you ever want to check alignment of the key to the column bed, mount a dial indicator in the spindle. Raise and lower the head while reading the vertical edge of a precision square. (See Figure 29.) Adjust the rotating column until there is no error as the indicator moves up and down the square. Now read the table with the indicator. If the slot and key are perfect there shouldn't be any error, but in most cases there will be a small amount. This can usually be eliminated by taking advantage of what play does exist in the alignment key and slot. With the cone point set screw loosened slightly, tap the headstock with a plastic mallet to take out play in the direction you want to go. Then retighten the set screw.

Making Final Adjustments

The rotating column and tilting adjustments can be finalized so the indicator needle shows no movement as the spindle is rotated, however the error we measured when checking the table flatness could be accounted for now if need be. If the pointer on the back of the rotary column disk doesn't line up with the zero mark, loosen the screw holding it in place and reset it to indicate zero for future reference. (Model 2000 mills and 5000-series mills with rotary column attachment only.)

Your machine is now "indicated in" and ready to use. As you get a feel for your machine and go through this adjustment procedure a few times, the time it takes to get good results will decrease. Being able to accurately indicate in a mill is one of the skills that must be developed by any machinist who plans on making accurate parts. Though the adjustments on larger machines may be made in slightly different ways, the skills and procedures you learn here can be applied to other machines as well.

Using the Column Spacer Block

Model 2000- and 5800-Series Mills (Standard)—In normal use the column spacer block will not be required. However, if you are working on a larger part or your setup requires more clearance

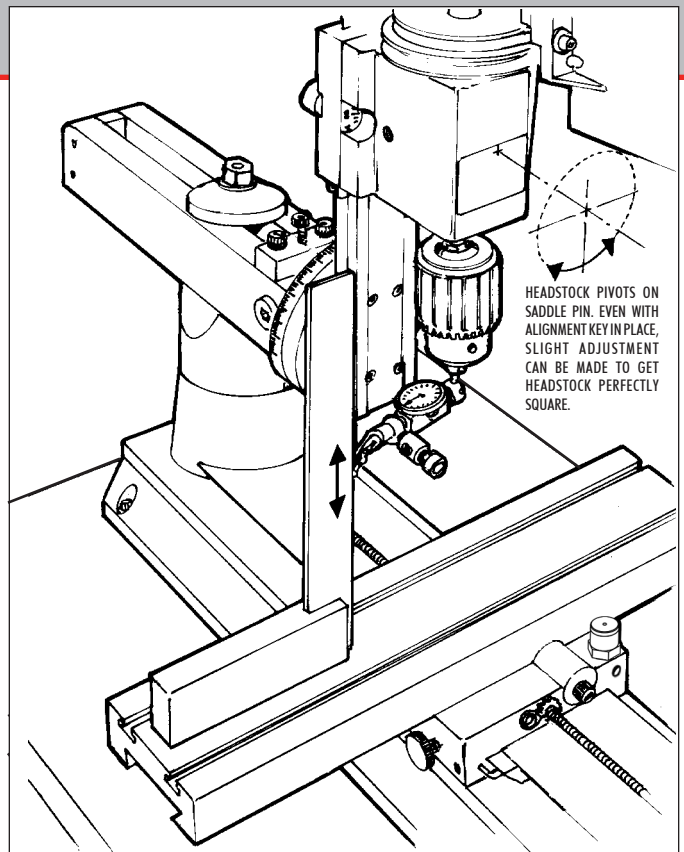

FIGURE 29—Fine tuning the headstock rotation alignment with a machinist's square and dial indicator. The headstock pivots on the saddle pin. Even with the alignment key in place, slight adjustment can be made to get the headstock perfectly square.

under the swing arm, the spacer block can be installed to raise the column an additional two inches. (Installation will be made easier if you first remove the headstock/motor unit to reduce the weight of the column.) To install the spacer block, remove the flange nut on top of the column hold-down bolt, and lift off the hold-down washer so that the entire column top and swing arm assembly can be lifted off of the hold-down bolt. Screw the extension bolt onto the end of the column bolt and tighten with an adjustable wrench. Slide the column spacer over the bolt and reinstall the column top and swing arm assembly. Reinstall the headstock/motor unit.

NOTE: The column spacer block (P/N 56770 + 56110) is included as standard with the Model 2000 mill. It is optional at extra cost on all mill column upgrades and 8-direction vertical milling columns and upgrades.

Model 5000- and 5400-Series Mills (Optional)—There is now an optional column spacer block available for use with the standard mill column. It is P/N 1300 and includes longer bolts needed to attach the column to the base through the spacer block. The spacer block will add 2" of additional distance between the spindle and the table. If you simply need more travel, there is also an optional 15" column bed (P/N 45260) and matching leadscrew (P/N 45270/45280), allowing your column to be converted from the standard 11" height to add four more inches of Z-axis travel. This taller column can be ordered as an extra cost option on all new mills.

Working with Setups that Require Extremely Low or High Column Travel

Model 2000- and 5800-Series Mills—An upgrade to the Model 2000 mill was introduced in March, 1999. It adds 1.6" of travel

to the lower end of the Z-axis movement so that end mills can be brought down below the surface of the table for working on the edge of parts. This travel extension is now standard on all Model 2000 mills. The headstock may be lowered even more by placing the column top (P/N 56550) above the swing arm instead of below it. Remove the flange nut, hold-down washer and swing arm. Place the swing arm over the hold-down bolt directly on top of the column base (P/N 56660). Place the column top back onto the hold-down bolt upside down and replace the hold-down washer and flange nut. Although you cannot use the alignment lines to help square up the head, this makes for a very strong and stable setup. In most cases the new travel extension will make this procedure unnecessary.

Should you wish to work on extremely tall setups that combine several holding devices (i.e., a chuck on top of a rotary table on top of a tilting angle table) you can extend Z-axis travel on the top end by either adding an additional spacer block to the column or by removing the saddle travel extension and attaching the saddle directly to the saddle nut as is done on standard Sherline mills. This information also applies to the 5800-series mills.

Using the Saddle Locking Lever

All Sherline Mills—Along with the travel extension, a new saddle locking lever was installed to replace the old saddle friction lock used prior to 2/99. This new locking lever is standard on all manual mills and vertical milling columns as of that date. This lever is located on the Z-axis leadscrew behind the saddle. When turned to the full clockwise position the saddle will move freely. A spring-loaded ball locates in a detent in the bottom of the lever to hold it in this position. To lock the saddle in position, move the lever to the full counterclockwise position. This locks the lever against the saddle nut which prevents the leadscrew from turning. The exploded views on page 45 (manual) and page 46 (CNC) show the location of the components.

Engineering Compromises

It is difficult when writing instructions on complicated procedures like describing the alignment procedure for this mill. By giving you this much information we know that it is making life easier for some customers by answering their questions. On the other hand, it is probably confusing to another customer who would never have asked the question, because of the type of work that they perform on their mill or lathe. We don't want to create a customer who spends all his time trying to achieve perfect alignment for work that doesn't require it and ends up never using the machine. Engineering is always a compromise. We deal with this fact with each new product that we design. While our machines aren't accurate enough for some customers, they are still too expensive for others. We hope you are pleased with the new capabilities this multi-direction mill can bring to your shop. We think you will find the combination of features offers a very good machining value.

Use of Cutting Oils and Lubricants

Much can be written about the use of lubricants, but they may usually be dispensed with where production rates are not very important. A small amount of any kind of oil applied with a small brush will be sufficient. Aluminum and its alloys may require the use of cutting oil to prevent the chips from welding to the tool's point. Do not use oils with a low flash point or a bad smell. If desired, a mixture of one part soluble oil to six parts water may be used on steel to assist in producing

a smoother finish and reduce tool chatter when parting off. Brass and cast iron are always turned dry. Cutting lubricants should be cleaned off the tools after use.

Cutting oils can be purchased at an industrial supply store. In the past it was sold only in "industrial" quantities that were too large for home shop use, however, several industrial suppliers now sell it in quantities small enough to be practical for the home machinist. Do not use high sulfur pipe thread cutting oil. It is good for hard-to-machine materials, but is so dirty to work with we do not recommend it. We also find some of the cutting fluids used for tapping are too smelly and unpleasant to use for general machining.

The main purpose of using lubricants is to keep the chips from sticking to the cutting tool. When used properly, modern high-speed tool bits are not likely to be affected by heat on the type of work usually done on miniature machine tools.

General Machining Terms

Two terms frequently used in machining are "feed" and "cut." Reference to the diagrams that follow will show what is meant by these terms. Normal turning on a lathe, when used to reduce the diameter of a work piece, involves advancing the cutting tool perpendicular to the lathe bed by an appropriate amount (depth of cut) and feeding the tool along parallel to the lathe bed to remove material over the desired length. (See Figure 30A.)

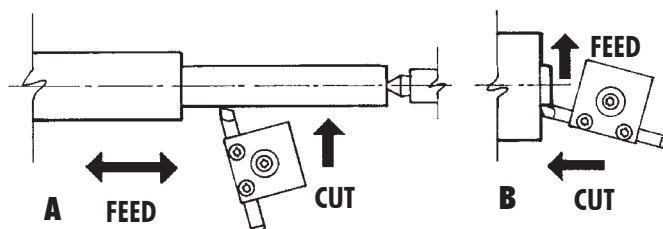

FIGURE 30—Directions of Feed and Cut showing (A) Turning work between centers and (B) Facing off a work piece

In normal lathe turning, the depth of cut is set by the crossslide handwheel, and the feed is provided by the handwheel on the end of the bed. When facing off the end of a work piece held in a chuck or faceplate, the depth of cut is set by the handwheel on the end of the bed, and the feed is provided by the crossslide handwheel. (See Figure 31.)

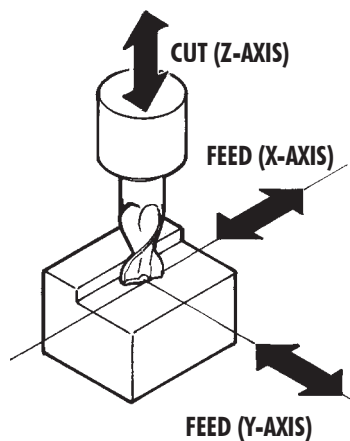

FIGURE 31—Directions of Feed and Cut when working with a milling machine

When using a mill, cut is determined by the amount of depth the cutter is set to by the Z-axis handwheel. Feed is supplied by either or both the X- or Y-axis handwheels depending on the desired direction of the cut.

What is “Tool Chatter?” To see a video demonstration of what “chatter” actually sounds like and how to cure it, see the Sherline website at sherline.com/test-cuts/. The page contains short video clips of various materials from Delrin to Inconel being cut on a Sherline lathe. At the bottom of the page is a link to a video demonstration of chatter.

General Rules for Feed Rates and Cutting Speeds

Before attempting to machine any metal, please try to remember this simple rule about machining:

*“If the tool chatters,
decrease speed and increase feed.”*

Understanding this simple rule can save you many hours of grief. When the tool “chatters,” it is not cutting in a continuous fashion. Metal likes to be machined in a way that allows the material to come off in a continuous strip while the tool is in contact with the metal. If the tool is not fed at a rate that is fast enough, the tool skips along the surface, occasionally digging in. The surface of the tool that is doing the most cutting will find a frequency of vibration that is a product of all the variables involved. This can cause anything from a high pitched whine on light, high speed cuts to a resonating racket that can rip the work out of the chuck on heavy cuts. If you maintain the same feed rate and reduce the RPM, the feed will increase because the chip will be thicker. (If that sounds wrong at first, think of it this way: At the same feed rate, if you cut the RPM in half, twice as much metal must be removed with each rotation to get to the end of the cut in the same amount of time. The chip is twice as thick, so the feed is GREATER at lower RPM if the feed RATE stays constant.)

When a tool chatters, it gets dull faster, because it must keep cutting through the previously machined surface that has been “work hardened” by machining. As you can imagine, there are limits to how much you can increase feed rate, so the answer lies in adjusting both speed and feed to achieve the proper cut. Proper cutting speed is the rate a particular material can be machined without damaging the cutting edge of the tool that is machining it. It is based on the surface speed of the material in relation to the cutter. This speed is a function of both the RPM of the spindle as well as the diameter of the part or size of the cutter, because, as the part diameter or cutter size increases, the surface moves a greater distance in a single rotation. If you exceed this ideal speed, you can damage the cutting tool. In the lathe and mill instructions, we give some examples of suggested cutting speeds, but what we wanted to get across here is that the damage isn’t a slow process. A tool can be destroyed in just a few seconds. It isn’t a case of getting only one hour of use instead of two. The cutting edge actually melts. If you machine tough materials like stainless steel, you will ruin more tools than you care to buy if you don’t pay a lot of attention to cutting speeds. Charts showing suggested cutting speeds for various materials are included in both the lathe and mill sections that follow.

Lathe Operating Instructions

CAUTION!

Read All Operating Instructions Carefully Before Attempting Any Machining Operations.

Leveling the Cutting Tool

Each type of turning work requires the correct tool for the job. It is important that the cutting tool be sharp and correctly set up in the tool post. The cutting edge of the tool should be exactly level with the center height of the lathe. Check this by bringing the tool tip up to the point of either the headstock center or tailstock center. (See Figure 32A.) We also manufacture a simple tool height adjustment gauge that allows you to check tool height at any time by measuring from the table surface. (See Figure 32B.)

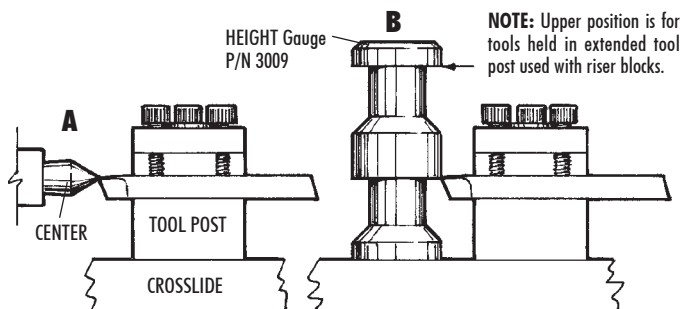

FIGURE 32—Leveling the tool using (A) the tip of a head- or tailstock center or (B) Sherline’s tool height gauge P/N 3009.

The standard Sherline tool post is designed to hold common 1/4" square tool bits which have had a few thousandths of an inch (.1 mm) ground off the top edge for sharpening. Loosen the hold-down bolt and slide the tool post as close to the point

of the dead center as possible. Inspect with a magnifying glass. The tip of the tool bit may be raised or lowered by sliding a shim* underneath it. The cutting edge must be on center or just below center (0.004" or .01 mm maximum). Ensure that the tool is fixed securely in position by firmly tightening the socket head screws. Try not to have the tool cutting edge protruding more than 3/8" (10 mm) from the tool post.

*NOTE: Thin metal shim stock is available for this purpose. If you don’t have any metal thin enough, a single thickness of paper business card stock will usually do the job. Do not use more than one thickness as it will compress too much. Our optional rocker tool post (P/N 3057) allows this adjustment to be made without shims. It comes standard with the Model 4400/4410 long bed lathe.

Initial Test Cutting

If you have never operated a lathe before, we suggest that you make a trial cut on a scrap of material to learn the operation of the machine. In a 3- or 4-jaw chuck, secure a piece of round aluminum stock approximately 3/4" (19 mm) diameter and 1-1/2" (38 mm) long. Secure the pre-sharpened 1/4" square right-hand cutting tool supplied with the lathe in the tool post, making sure that it is properly positioned. First, turn the speed control all the way counter-clockwise, then turn the motor on. Bring the speed up to approximately 1000 RPM (about 1/3 speed). To establish tool position in relation to the work, bring the tool in slowly until it just starts to scribe a line on the work. Crank the tool towards the tailstock until it clears the end of the work. Advance the tool .010" (.25 mm) using the crossslide handwheel (10 divisions on the inch handwheel scale). Using the bed handwheel, move the tool slowly across the work toward the headstock.

Cutting tools used on lathes are designed to remove metal much as paper is removed from a roll. It takes a positive feed rate to accomplish this. If the feed rate isn’t fast enough, it

would be similar to tearing an individual sheet of paper off the roll. The results when cutting metal would be shorter tool life, a poor finish and tool “chatter.” Chatter is a function of rigidity, but it is controlled by speed (RPM) and feed rate.

Since you already have a piece of aluminum chucked up, experiment with speed and feed rate. You just took a cut of .010" (.25 mm) and probably noticed that the machine didn't even slow down in the slightest. Now take a 1/2 inch long cut .050" or 1 mm deep, which is one complete revolution of the handwheel. If you used the sharpened cutting tool that came with your machine, it should have made the cut easily. If the tool “squealed,” reduce the RPM a little and take another .050" cut while feeding the tool faster. You will probably be surprised at how easily your machine takes cuts this heavy.

Inducing Chatter and Learning How to Overcome It

To better understand what is going on, we will now purposely try to make the machine “chatter.” Make sure the stock you are cutting is sticking out of the chuck no more than 1 inch (25 mm). Crank the handwheel two turns further in from the last setting which will give you a .100" (100 thousandths of an inch) or 2 mm cut. Set the spindle speed to about 1000 RPM (1/3 speed) and feed the tool slowly into the material. Vary speed and feed until you get a substantial chatter. Without changing the depth of the cut, drop the speed to about 200 RPM and feed the tool into the work with more force. The chatter should disappear. Once you have learned to control chatter by adjusting speed and feed, you will be well on your way to becoming a machinist.

Holding the Workpiece

Work can be held between centers, in 3-jaw or 4-jaw chucks, on the faceplate or with a collet. Sometimes it is necessary to use a chuck and center, and, if the work is spinning fast, a live center should be used. (See Figures 33, 34 and 35.)

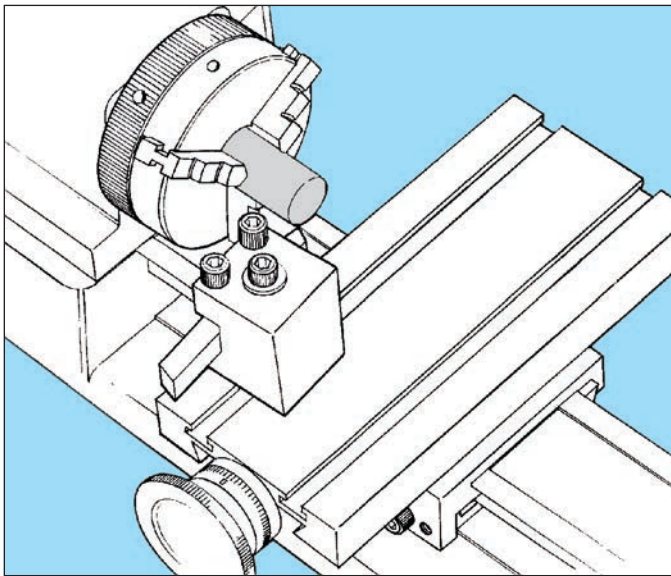

FIGURE 33—Holding a round work piece in a 3-jaw chuck.

Turning Between Centers

This is done by fitting the dog to the work which is to be turned and placing the work and dog between the centers in the headstock and tailstock. The maximum diameter that can be held with the dog is 5/8" (15 mm). (See Figure 35.)

The dog is driven by fitting it into one of the faceplate holes. This method of turning is ideal for bar work or turning of steps on a bar. The tailstock center must be greased to prevent overheating. (An optional live center—such as P/N 1191—turning on ball bearings is the solution preferred by most machinists.) The headstock spindle has a #1 Morse taper in the spindle nose. The tailstock spindle has a #0 Morse taper.

Removing Tools from the Morse Taper Spindles

HEADSTOCK—Accessories held in the Morse #1 taper of the headstock spindle can be removed with the use of a knockout bar (not supplied) approximately 3/8" in diameter and 6" long. The bar is inserted through the back of the spindle, and accessories, such as centers, can be removed with a few taps. Accessories like the drill chuck that are drawn into the spindle taper with a drawbolt are removed by loosening the drawbolt a few turns and then giving the head of the bolt a sharp tap with a mallet to break the taper loose. Supporting

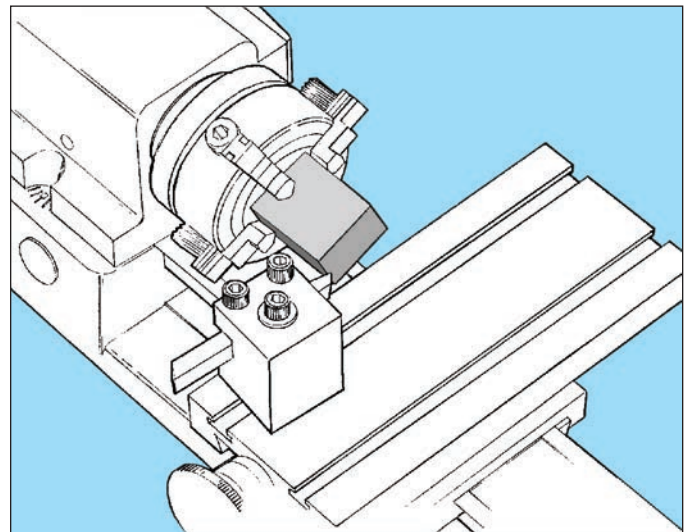

FIGURE 34—Holding a square work piece in a 4-jaw chuck.

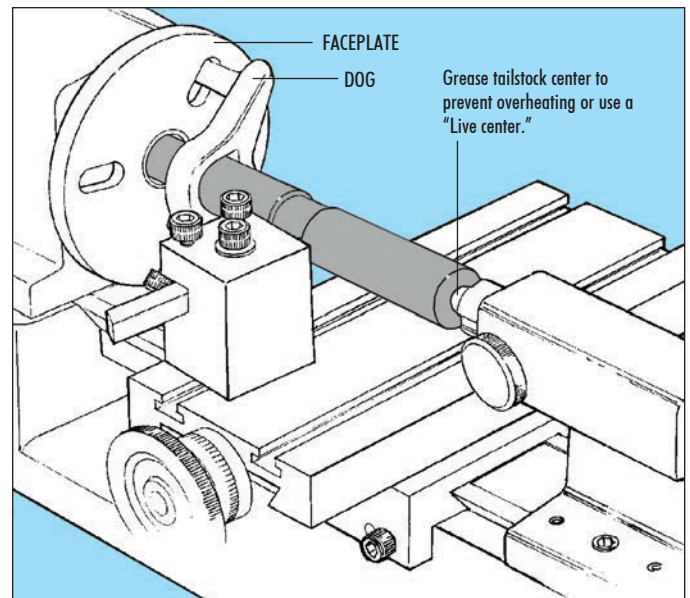

FIGURE 35—Turning between centers with a faceplate and drive dog.

the headstock by lowering it onto a block of wood extending to the table on the mill will keep from knocking the column out of alignment.

TAILSTOCK—The tailstock spindle does not have a through hole and a drawbolt is not used. It is equipped with a Morse #0 taper, and accessories such as drill chucks and centers can be removed by turning the handwheel counter-clockwise until the back of the taper hits the inside of the spindle and the accessory is ejected

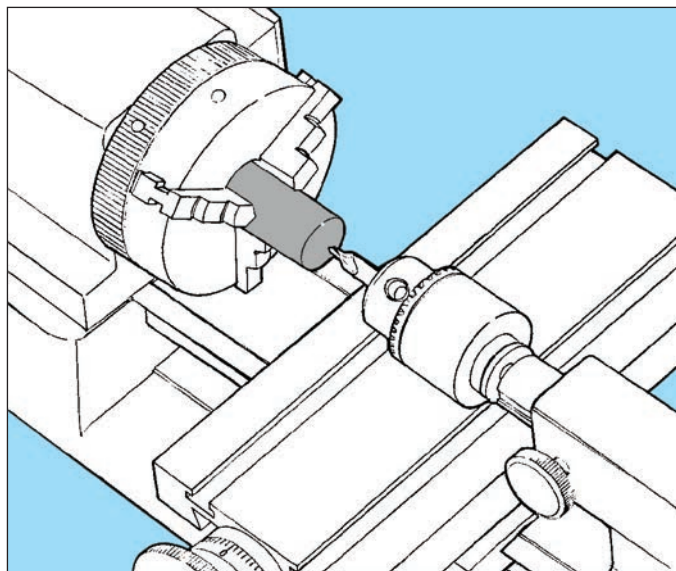

FIGURE 36—Tailstock center drilling. The work turns while the drill is held stationary in the tailstock.

Center Drilling

Because the work turns and the drill does not on a lathe, it is necessary to use a center drill before a standard drill can be used. Due to the flexibility of a standard drill bit, it will tend to wander on the surface of the rotating work, whereas a center drill is designed to seek the center and begin drilling. The 60° point of the center drill makes a properly shaped index hole for the tip of a live or dead center. It also provides an accurate starting point for a standard drill. Cutting oil is recommended for all drilling operations. A center drill should be withdrawn, cleared of chips and oiled several times during the drilling of a hole to keep the small tip from breaking off.

For more information, see the chart of commonly available center drill sizes on page 34.

Tailstock Drilling

Hold the work in a 3- or 4-jaw chuck. If the work is longer than approximately 3" (76 mm), support the free end with a steady rest. Seat the drill chuck's #0 Morse arbor into the tailstock spindle and secure a center drill in the chuck. Adjust the tailstock to bring the center drill close to the work and lock it in position. Turn the tailstock handwheel to bring the center drill forward. After the hole is started with the center drill, switch to a standard drill bit of the desired size to drill the hole. (See page 34 for more on drilling holes.)

The easiest way to center drill the end of a round shaft that has a diameter too large to be put through the spindle to support it with a steady rest (P/N 1074) while the end is being drilled. If this isn't possible, find the center with a centering square,

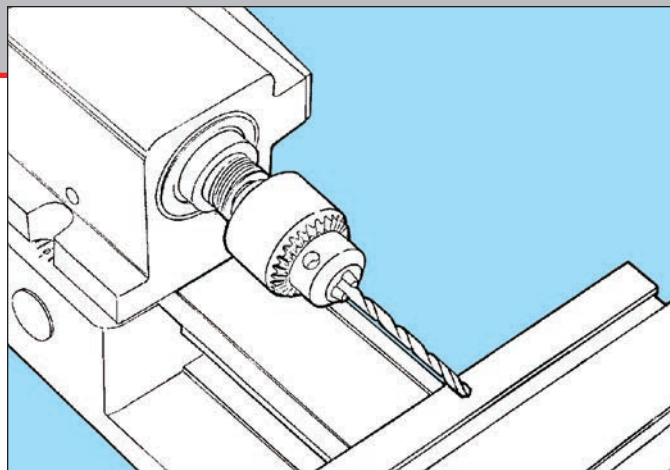

FIGURE 37—Headstock drilling. The drill turns in the headstock spindle while the work is held stationary.

prick punch a mark and center drill by hand. (See page 25 for a photo of a steady rest.)

Headstock Drilling

The drill chuck comes fitted with a #0 Morse arbor that fits in the tailstock spindle. To use it in the headstock, you will need to first change to the #1 Morse arbor that is included with your chuck. To change arbors, put the drill chuck key in its hole to give you better purchase to grip the chuck while using a wrench to remove the #0 arbor. Replace it with the larger #1 arbor. Put the drill chuck in the headstock. Then put the drawbolt with its washer through the spindle hole from the other end of the headstock and tighten the drawbolt. **DO NOT OVERTIGHTEN!** (See Figure 37.)

Reaming

Twist drills will generally not drill perfectly accurate sizes, and very small boring tools are not satisfactory in deep holes because of their flexibility. Therefore, reaming is used for holes requiring accuracy within .0005" (.013 mm). Reamers are available in any standard size, but they are rather expensive and are generally not purchased to do one-of-a-kind type work. Use them only when a boring tool cannot be used because of the depth or size of the hole. Because of their length, they cannot always be used on a small lathe.

Reamers are used only to "clean up" a hole. To make an accurate hole, the work is drilled approximately .010" (.25 mm) smaller than the reamer size. The work should be slowly rotated and the reamer slowly fed into the hole while applying plenty of cutting oil. The reamer should be frequently removed and cleared of chips. Never rotate a reamer backwards in the work as this can dull the cutting edges.

Faceplate Turning

The faceplate has three slots that allow work to be bolted to its surface. Flat work can be screwed directly to the faceplate. Extra holes can be drilled to suit odd shaped work unsuitable for a chuck. If the work is mounted off-center, be sure to counterbalance the faceplate and use very low RPM. Don't hesitate to drill holes in or modify the faceplate as needed to do a particular job. That's what they are for. They are inexpensive and you can have several on hand modified for special jobs.

Taper Turning

On some lathes, a taper is cut by offsetting the tailstock. On the Sherline lathe, taper turning is done by removing the headstock key and turning the headstock to any angle away from dead center. To rotate the headstock, the alignment key

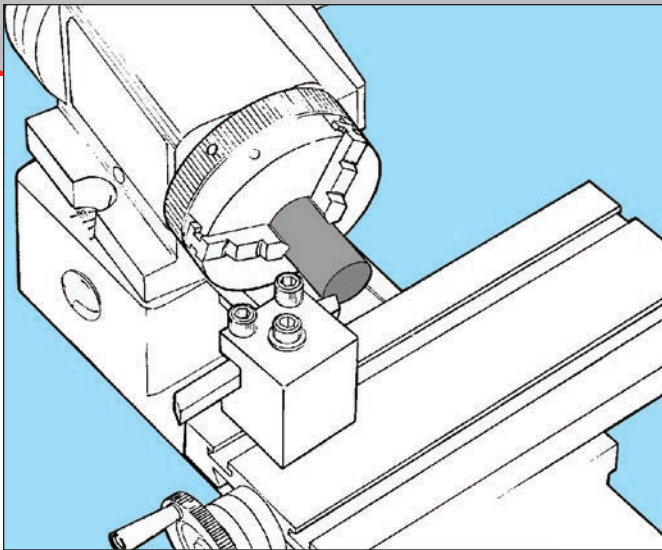

FIGURE 38—Turning a taper with the headstock slightly rotated.

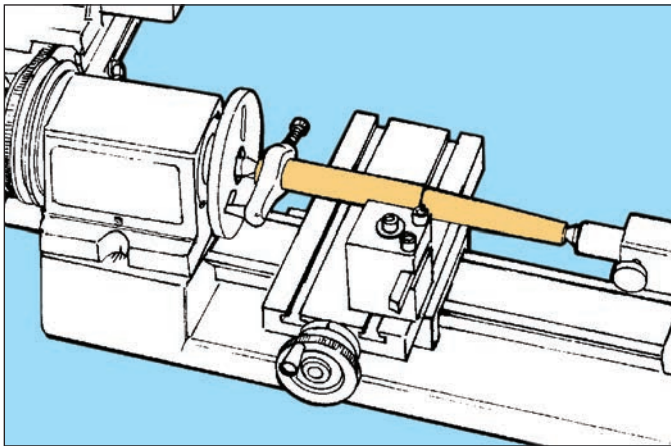

FIGURE 39—Long, shallow tapers can be cut in a continuous pass by pivoting the headstock to the proper offset while supporting the other end with the tailstock. The work is driven by using a drive dog in the faceplate. The dog acts like a “universal joint” as the drive pin slides in the faceplate slot. A dead center is used here in the tailstock but an optional live center could also be used.

must first be removed. Loosen the set screw in the front of the headstock, and lift the headstock and motor unit off the locating pin. Tap the alignment key out of its slot on the bottom of the headstock, and replace the headstock unit on the pin. While pressing down on the headstock, rotate it to the angle you desire by referring to the angle scale on the bed. The base is calibrated in 5° increments up to 45° on either side of center. When set to the proper angle, retighten the set screw against the pin to lock the headstock into position. Tapers can also be cut without turning the headstock by using a compound slide (P/N 1270).

Short work can be inserted in a 3- or 4-jaw chuck and turned as shown in Figure 38. If the headstock is angled towards the lathe front, the taper will be cut smaller at the right. Tapered holes can also be bored in work held in the 3- or 4- jaw chuck. To machine a taper on longer stock, center drill both ends of the bar, set the headstock angle and mount the part between centers using a faceplate and drive dog. (See Figure 39.)

Tool Shapes and Grinding Your Own Cutting Tools

The shaping of cutting tools to suitable angles for the type of material and nature of work being performed can be very

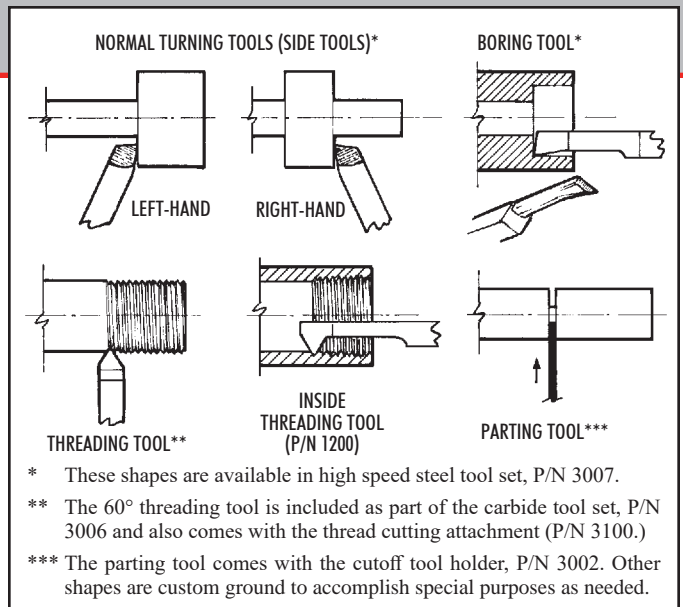

FIGURE 40—Cutting tool shapes

important to satisfactory work. When tools become dull, gently re-grind and preserve the original angles and shapes. Do not grind the top face of the tools, but confine sharpening to the end and/or sides except form tools which are ground on the top surface. Remember that heavy cuts and rapid feed will cause greater strain on the chuck and lathe. This may induce “spring” or binding of work and tools that can produce a poor finish.

NOTE: Because of the importance of a sharp and properly ground tool to the cutting process, Sherline has prepared a special instruction sheet on *Grinding Your Own Lathe Tools*. There are a few tips that can make the process a simple one. The instructions are included with each lathe and with cutting tool sets when you order them from us, or you may call us and request a copy. (Cost is \$5.00 postage paid.) They are also available from our website at no cost. (See sherline.com/test-cuts/.) Unfortunately, space does not permit us to reprint them as part of this booklet.

Cutting tools are ground to various shapes according to their usage. Tools are usually ground to shape as needed by the operator. Some standard tools are described below:

Normal Turning Tool—or RIGHT-hand tool feeds from right to left, is used to reduce work to the desired diameter and is the most frequently used of all tools.

Side Tools—These are used to face off the ends of shoulders and may also be used as normal turning tools. **Note** that a tool that is fed from left to right and has its cutting edge on the right is called a LEFT-hand side tool because the chip comes off to the left. Cutting tools are named based on which direction the chip comes off, not which side has the cutting face.

Parting Tool—The conventional parting tool or cutoff tool is shaped like a dovetail when viewed from above and is used to cut off work pieces by feeding the end of the tool across the lathe bed and through the work piece. The Sherline parting tool instead uses a thin .040" (1 mm) blade that has a slightly thicker ridge at the top to accomplish the same job of providing clearance for the tool while cutting. Parting tools thicker than .040" (1 mm) will be too thick for use on your Sherline lathe.

Boring Tool—A boring tool is used in the tool post on a lathe or in an off-settable boring head on a mill to enlarge holes in a work piece. (See Figures 41 [lathe] and 58 [mill].)

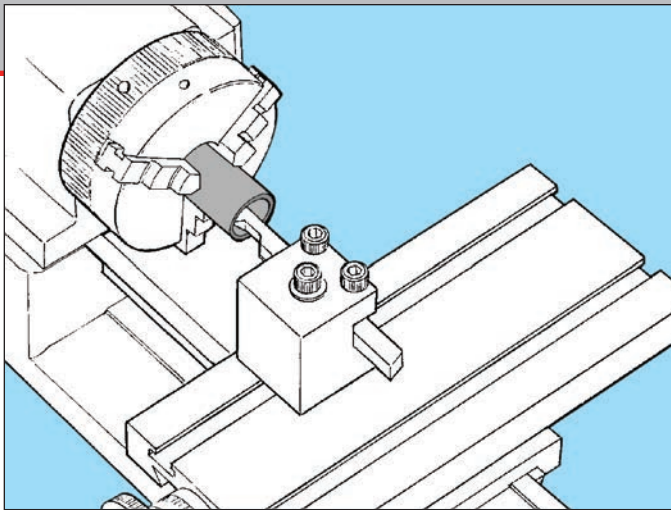

FIGURE 41—A boring tool in use on the lathe

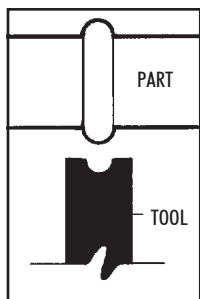

FIGURE 42—Form tool and part

Form Tool—A custom contour can be ground into a tool to produce a special shape like a radius in a part. The width of the cutting edge must be less than 2-1/2 times the smallest diameter. Cutting speed must be slow to prevent chatter.

The clearances ground behind the cutting edges indicate the type of material for which the tool may be used and the direction in which it is fed along the work. When grinding tool bits, correct clearances are essential or “rubbing” can occur.

The shape shown here would be difficult to grind on a home bench grinder, however, the same form could be achieved by grinding two separate tools with half the needed arc on the outside corner of each tool—a “left” and a “right.” By using a number of simple shaped tools in sequence, complicated forms can be generated.

Turning Tools (Left- and Right-Hand)—Reference to Figure 43 will illustrate the lateral positioning of this tool. Note the clearance behind the point between the end of the tool and the work. Insufficient clearance will cause the tool to “rub,” and excessive clearance will produce a ridged or wavy finish due to the small length of tool edge in contact with the work. This ridging becomes more pronounced with rapid feed. To provide a smooth finish, the sharp cutting point may be slightly rounded with an oil stone, taking care to preserve the side clearance underneath this corner.

This type of tool should not be advanced directly end-wise into the work. The depth of cut is set while the tool is clear of the end of the work. The starting procedure is to advance the tool until the point just touches the work. Note the reading on the crossslide handwheel, withdraw the tool slightly and move along until clear of the end of the work. Now advance the crossslide to the above reading, add desired depth of cut and then feed the tool along the work piece the desired distance. Withdraw the tool clear of the work, having noted the reading on the crossslide handwheel. Mentally note the reading on the leadscrew handwheel, return the tool to starting position and advance to the previous reading **plus** the desired cut.

NOTE: Sherline offers optional adjustable “zero” handwheels that allow you to reset the handwheel to zero at any time...a

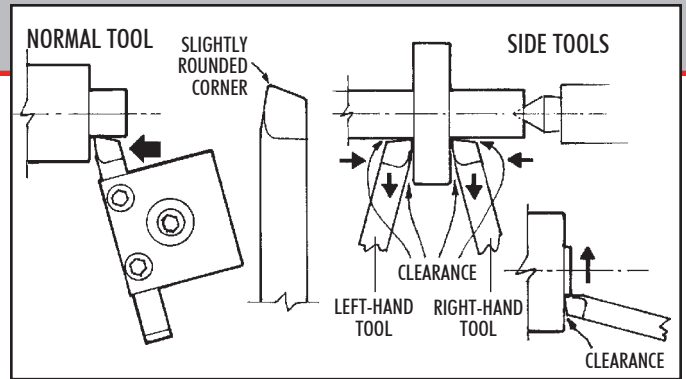

FIGURE 43—Arrows show direction of tool feed in all diagrams.

handy feature normally found only on larger, more expensive machine tools. New tools may be ordered with them already installed, and existing tools can be retrofitted with them on any axis.

The second feed is now commenced, stopping at the same reading on the leadscrew handwheel as before. This procedure enables turning to accurate length.

Repeat the procedure until the work has been reduced to within about .010" (0.25 mm) of desired diameter, noting that each .015" (0.4 mm) increase in depth of cut will reduce the work diameter by twice this amount; that is, .030" (0.8 mm). For the finishing pass, advance the tool by the required amount and feed along the work just far enough to gauge the finished diameter. Adjust depth of cut if necessary and complete the final pass using a SLOW feed to obtain a smooth finish and exact size.

Using the Cutoff or Parting Tool

(See Figure 44.) After completing a part in the lathe, it is frequently necessary to separate the part from the excess material used for chucking. This operation is best accomplished with the use of a cutoff tool or “parting tool” as it is sometimes called. The Sherline cutoff tool and holder utilizes a very slender, high-speed tool steel cutting blade mounted in a special tool holder. The thinness of the blade (.040") enables it to feed into the part quite easily and at the same time minimizes the amount of waste material. A word of caution: Never use a parting tool on a part mounted between centers. The part may bind on the cutter, resulting in a scrapped part or a broken cutting tool.

Always try to lay work out so the cutoff tool is used as close to the spindle as possible. Set blade height by sliding the blade back and forth in the slightly angled slot in the tool holder. It should be set so the tip is aligned with the centerline of the part being cut. An unusual diameter may require a shim under the front or rear of the holder to accomplish this. The tool can also be mounted on the back side of the table by using the rear mounting block, P/N 3016.

IMPORTANT!

Always use cutting oil when using the cutoff tool. The cut will be made much smoother, easier and cooler.

The turning speed for parting should be about one-half the normal turning speed, and feed rate should be a little heavy so the chip will not break up in the slot. If speed and feed are correct, there will not be any chatter, and the chip will come out as if it were being unrolled. Cutting oil plays a major roll in this occurring properly.

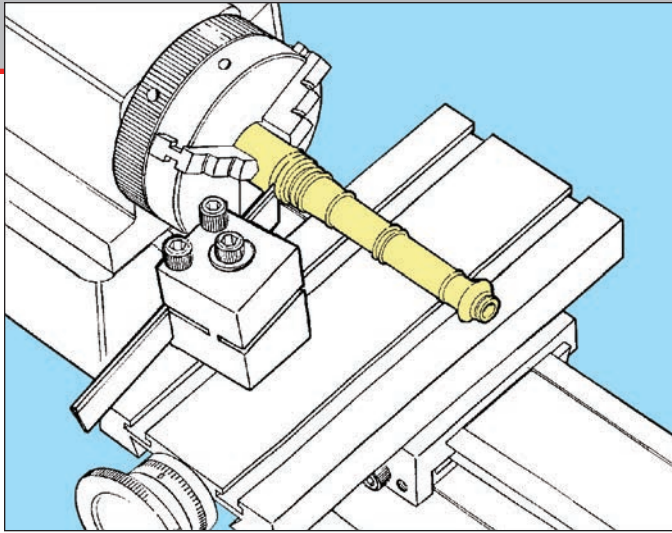

FIGURE 44—A parting tool used to separate a part from its bar stock.

If the tool chatters, first check to see if the work is being held properly. Then decrease speed (RPM) or increase feed rate or both. Once the blade has chattered, it leaves a serrated finish that causes more chatter. Sometimes a serrated finish can be eliminated by stopping the spindle, adding a liberal amount of cutting oil, bringing the blade up so there is a slight pressure on it without the spindle turning, and then turning the spindle by hand or as slowly as possible with the speed control.

Very small work may be completely cut off when held in a chuck and allowed to fall onto the crossslide. It is too small and light to cause any damage. Hollow articles, such as rings, may be caught on a piece of wire whose end is held in a suitable position.

Side Tools

While these may be, and often are, used as general purpose turning tools, their specific use is for facing the sides of collars and shoulders; that is, finishing these to correct dimension and with a smooth, flat surface. They are also for facing work held on a faceplate or in a chuck. The facing of work in this manner is very useful for the production of truly flat surfaces and for producing articles to an exact thickness. The uses of side tools are illustrated in Figures 40 and 43. The sharp corner at the cutting point should not be slightly rounded, as may be done with the normal turning tool, as knife tools may be required to produce sharp corners.

Boring Tools

The use of this tool requires the existence of a drilled or cored hole, or it may be used to enlarge the bore of a tube. The work must be mounted in a chuck or on a faceplate and the boring tool set as shown in Figure 41. Note the clearance behind the cutting point as shown in Figure 45.

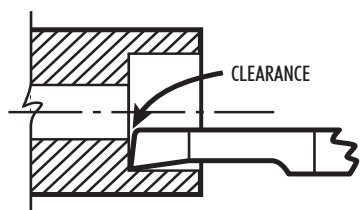

FIGURE 45—Boring tool clearance

A slow rate of feed should be used, as the turnings are not able to escape freely from the hole and can jam the tool. Frequent withdrawal of the tool to allow turnings to escape may be necessary. Care should be taken not to feed the tool beyond the depth required or to feed so deeply as to damage the chuck or faceplate.

Where a hole must be bored right through the work, it should be shimmed out from the faceplate to provide clearance for the tool to feed through. The leadscrew handwheel graduations can be used to indicate the correct depth at which to stop the feed. Notice that, with boring, the depth of cut is increased by moving the tool and crossslide towards the operator and not away as with normal turning.

The boring of holes often necessitates greater than normal overhang of the tool from the tool post, so the depth of cut and rate of feed should be reduced from normal.

Inserted Tip Carbide Tools

Sherline brings the home shop machinist into the space age with cutting tools that add a new dimension to small lathes. When working with tough metals, high-speed steel tools need constant sharpening and have a relatively short life. Brazed carbide tools cut great but chip easily. Inserted carbide cutting tools are the answer and have replaced those other tools in the modern machine shop. Carbide inserts have the ability to consistently give good finishes and long tool life at a much higher cutting speed. This is especially important with small lathes, because they do not have excessive power at low RPM. With inserted carbide tools you can cut stainless steel at the same RPM you were formerly using to cut aluminum with high-speed steel tools without any sacrifice in quality in surface finish.

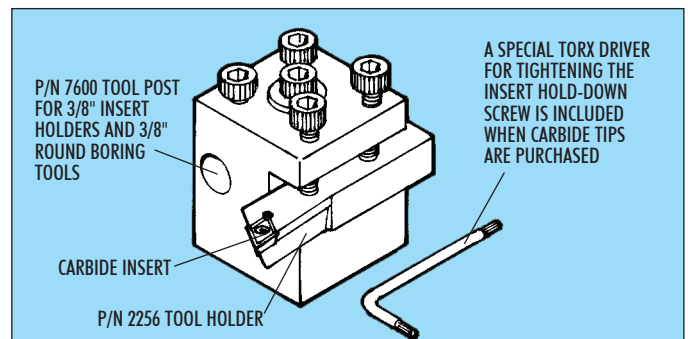

FIGURE 46—Carbide insert tool and tool post. The tool post holds both 3/8" square and round tools.

These tools are more expensive than high-speed steel, however, they are worth every penny if you have problems grinding your own steel tools or are cutting exotic materials like stainless steel. Sherline offers a tool post (P/N 7600) that holds the larger 3/8" square tool shanks used to hold carbide, ceramic or diamond inserted tips. It also has a 3/8" round hole for boring tools.

A good starting point for an inserted tip tool is the P/N 2256 right-hand holder with a 35° offset. This holder uses the P/N 7605 carbide insert, which is a 55° insert good for turning, facing and profiling. A left-hand tool is also available as P/N 2257, or a set of both left- and right-hand tools is P/N 2258. Tools are also available to hold 80° inserts, which are slightly less versatile but offer longer tool life because of their stronger, more square shape. These tools should not be used to cut hardened steels or piano wire. Materials such as those are normally ground to shape, not cut, although ceramic inserts can sometimes be employed to cut these materials. Abrasive materials such as glass-reinforced plastics can be easily cut with these tools.

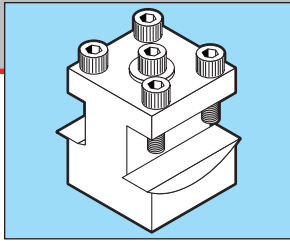

FIGURE 47—Two-Position Rocker Tool Post (P/N 7603)

Another tool available to Sherline machinists that holds carbide inserts is the 1/4"-3/8" two-position rocker tool post, P/N 7603 (See Figure 47). This tool post has slots on two opposite sides to hold both 1/4" and 3/8" square shank tools individually or at the same time. This allows you to switch quickly between tools of the two different sizes simply by rotating the tool post. The 3/8" side is designed to fit the larger 3/8" square tool holders commonly used for carbide or diamond inserted tips. Adding this tool post to your arsenal will allow you to keep both your standard 1/4" high-speed steel tools set up for jobs where they are sufficient and also have a 3/8" carbide insert tool ready for jobs where it is required.

Sherline also offers a ceramic insert and holder, P/N 2265. (See Figure 48.) The 3/8" IC negative rake ceramic indexable holder will bring a lot of enjoyment to your machining, particularly if you choose to turn hard materials such as tool steel or abrasive materials like fiberglass or composites.

When searching for a mirror-like finish on copper or aluminum, diamond inserts are also available. Though expensive, certain jobs can make their use desirable.

While inserted tip carbide, ceramic and diamond cutting tools will improve the performance of the Sherline lathe, they will not correct poor machining technique. Rigid setups are a must for tools such as these.

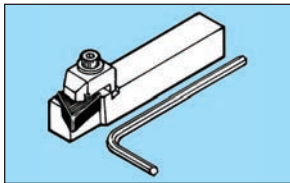

FIGURE 48—The P/N 2265 negative rake ceramic insert and 3/8" holder make it possible to cut hardened tool steels.

Turning Speeds

The following chart in Figure 49 provides a guide to speeds at which work of differing materials should be rotated. **Note** that the turning speed is inversely proportional to the diameter of the work; that is, the larger the diameter, the slower the turning speed. Material often differs in hardness, so these figures may have to be adjusted. The harder the material, the slower the turning speed should be.

Guide to Approximate Turning Speeds				
Material	Cut Speed	1/4" (6mm)	1/2" (13mm)	1" (25mm)
	S.F.M.	Diameter	Diameter	Diameter
Stainless, 303	67	1000 RPM	500 RPM	250 RPM
Stainless, 304	50	800	400	200
Stainless, 316	47	700	350	175
Steel, 12L14	174	2600	1300	650
Steel, 1018	87	1300	650	300
Steel, 4130	82	1250	650	300
Gray Cast Iron	57	900	450	220
Aluminum, 7075	400	2800	2800	1400
Aluminum, 6061	375	2800	2800	1400
Aluminum, 2024	268	2800	2000	1000
Brass	400	2800	2800	1400

FIGURE 49—High-speed steel cutting tool turning speeds

New Sherline Accessories

Sherline introduces new accessories every year. See our website for new product introductions.

sherline.com/whats-new/

Keep in mind that, apart from possible production of excessive heat and the fact that excessive speed may damage the cutting edge or cause it to "rub" instead of cutting, turning speeds are not too critical. Slower than normal speeds cause no harm, except by increasing the time involved. Aluminum, however, usually gives a better finish turned at high speed and with the use of lubrication (coolant).

Accessories for Your Lathe

Your lathe can be made more versatile with the addition of suitable attachments and accessories. These include various chucks and collets, a thread-cutting attachment, vertical milling column, knurling tool, a live center and many others. Remember that accessories and attachments must be cared for in the same way as the lathe. Always make sure that threads are free from metal chips and dirt. Chucks should be lightly oiled frequently so that they continue to function smoothly and accurately. Gears in the thread-cutting attachment should be lightly greased when in operation. Some attachments have moving slides, and these should be lubricated in the same way as the slides in your lathe. Each accessory comes with complete instructions for its use when it is purchased.

3-Jaw, 4-Jaw and Drill Chucks

Chucks are used to hold work in the lathe. They can also be used to function like a vise to hold a part for milling. Drill chucks can be used in the lathe headstock or tailstock or in the mill for drilling. Here are some of the chucks available for your Sherline tools:



Three-Jaw Self-Centering Chucks—Three jaws scroll in unison to grip round or hex stock. The 2.5" chuck (P/N 1041) holds from 3/32" (2 mm) up to 1-3/16" (30 mm) in diameter. Jaws are reversible for holding larger stock up to 2-1/4" (56 mm) in diameter. The chuck has a .687" (17 mm) through hole and 3/4-16 spindle thread. The larger 3.1" (70 mm) diameter P/N 1040 chuck is similar but holds parts up to 2-3/4" in diameter with the jaws reversed.



Four-Jaw Self-Centering Chucks—These scrolling chucks hold round or square stock. The 2.5" diameter P/N 1075 version holds from 3/32" (2 mm) up to 1-3/16" (30 mm). With the jaws reversed, it will grip stock up to 2-1/4" (56 mm). The jaws scroll in unison as on the 3-jaw chuck. (**NOTE:** stock held in this chuck must be perfectly round or square to be gripped by all four jaws.) The larger 3.1" diameter version of this chuck is P/N 1076, which can hold parts up to 2-3/4" in diameter with the jaws reversed.



Four-Jaw (Independent) Chucks—Each jaw is adjusted independently, allowing precise adjustment for perfect centering or for holding odd-shaped parts. Four-jaw chucks take a little more time to use, but offer much greater accuracy and versatility than a 3-jaw chuck. Holding range is the same as for the 2.5" and 3.1" 3-jaw chucks above. The 2.5" 4-Jaw is P/N 1044 and the 3.1" 4-Jaw is P/N 1030.

Jacobs Drill Chucks—Various size conventional Jacobs drill chucks



are fitted with a #0 Morse arbor for use in the tailstock for center drilling parts. They also come with a #1 Morse arbor and drawbolt for use in the headstock on the lathe or mill. Adjustment keys are included. Chucks available include a 5/32", 1/4" and 3/8" size.

5/32" Drill Chucks—These small chucks hold tiny drills from size #80 up to 5/32". Because they have a #0 Jacobs taper in the back, the adapter arbor must be pressed in, so it is not interchangeable. P/N 1010 comes with a #1 Morse arbor and P/N 1015 has a #0 Morse arbor. A sensitive drilling attachment (P/N 1012) using this same chuck is available for the mill.

1/4" Drill Chucks—The 1/4" drill chuck has a threaded hole in the back so it can accept either a #1 Morse or #0 Morse arbor. Drills from 1/4" down to 3/32" can be held in the chuck. P/N 1072 comes with both arbors, a drawbolt and key for use on either the lathe or the mill. P/N 3072 comes with just the #1 Morse arbor, drawbolt and key for use on the mill.

3/8" Drill Chucks—Like the 1/4" chucks, the 3/8" chuck has a threaded hole to accept either a #1 or #0 Morse arbor. Drills from 3/8" down to 3/32" can be held. P/N 1069 includes both arbors, drawbolt and key, while P/N 3073 includes just the #1 Morse arbor, drawbolt and key.

Lathe Headstock Hard-Stop Kit, P/N 40116



Every Sherline headstock now includes the holes to add an optional hard stop. The hard-stop kit, P/N 40116*, includes two hardened steel rods and a knurled thumbscrew lock. The .242" diameter steel rods are 4" and 8" long. A hole through the headstock base allows the hard-stop rod to be set to contact the lathe table, providing a hard stop for the Z-axis during turning operations. (*Headstock not included)

Thread Cutting Attachment, P/N 3100

Common threads are most easily cut using taps and dies, but it would be impossibly expensive to own a tap and die for every conceivable thread size. Cutting threads on a lathe is the traditional alternative and one of the real advantages of owning a lathe. A lathe cuts threads by gearing the leadscrew directly to the spindle. This is called "single pointing" a thread. When the spindle turns, the saddle moves.

Sherline's thread cutting attachment provides all the necessary gears and support arms to cut any thread from 80 TPI down to 5 TPI. Both left-hand or right-hand threads can be cut.

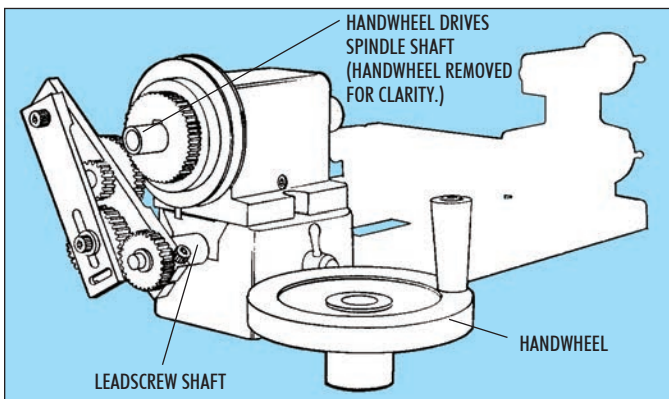

FIGURE 50—Sherline's thread cutting attachment. (Handwheel is removed for clarity.)

With this attachment and your lathe, you will never be stuck without a way to come up with the right thread. Even if a tap or die is available, you can set up and cut a thread faster than you could get to the store and back to buy it, and you'll save yourself some money as well!

Steady Rest, P/N 1074



A steady rest supports longer work with three adjustable brass pads that rub on the outside surface of the part. It keeps long parts from deflecting away from the tool or from wobbling while turning and centers the end of a part for center drilling. Along with a live center, this is one of the first accessories most lathe owners acquire.

Live Center, P/N 1197



The lathe comes with a "dead" (non rotating) center for the tailstock. This is the traditional way of supporting the free end of long work, but a live center is more popular for this task. On a "live" center, the center point rotates in a ball bearing, turning with the work. This eliminates the need for lubrication at the tailstock center and prevents the buildup of heat from friction.

Digital Readouts, P/N 8200

Add the convenience of electronic digital readout to your lathe. They can be ordered that way from the factory or you can install them as an accessory later. Reads out to .0005" or .01 mm plus a readout of spindle speed is also included. Return the count on any axis to zero with the push of a button. No more counting handwheel revolutions on long moves (For instructions on installing DRO see page 37).



Learning About Other Accessories for Your Lathe

The best place to learn about Sherline accessories is on our website. Instructions for their use are posted there. A complete list of accessories with links to instructions for each can be found at sherline.com/product-information/sherline-accessory-instructions/. If you do not have an Internet connection, Sherline offers a collection of printed instructions called the Sherline Accessories Shop Guide, P/N 5327. A color catalog featuring the tools and accessories may be requested by calling (800) 541-0735 or (760) 727-5857.

Additional Tips from Sherline Machinists

For some helpful tricks and tips when working with your Sherline machines see sherline.com/tips/.

3-Jaw Chuck Operation and Maintenance

The 3-jaw self-centering chuck is the most popular of all the accessories available for the Sherline lathe. It is available in both 2-1/2" diameter (P/N 1041) and 3-1/8" diameter (P/N 1040). These chucks will grip round or hexagonal work quickly, since the jaws move simultaneously to automatically center the work being held. The jaws on the chuck are designed so that the same chuck can be used for both internal and external gripping. Jaws are reversible for holding larger diameter work. Due to the nature of the design of a 3-jaw chuck, it cannot be expected to run perfectly true. Even 3-jaw chucks costing five times more than the one made for this lathe will have .002" to .003" runout. If perfect accuracy is desired in a particular operation, the use of a 4-jaw chuck is recommended. Each jaw is adjusted independently so parts can be centered with total precision. Both a 2-1/2" and 3-1/8" 4-jaw chuck are available for the Sherline lathe as P/N 1044 and P/N 1030 respectively.

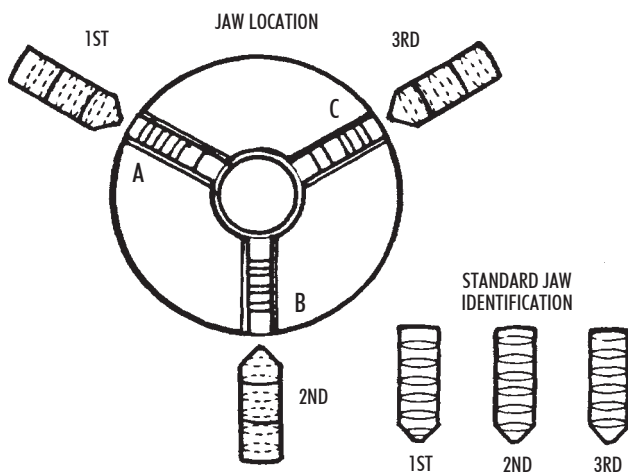

FIGURE 51—Jaw locations and identification.

NOTE: Do Not Turn the Lathe Spindle On Without Having the Chuck Jaws Tightened on Themselves or a Part!
The acceleration of the spindle can cause the scroll to open the chuck jaws if not tightened!

The 2-1/2" 3-jaw chuck (P/N 1041) is designed to take up to 1-3/16" (30 mm) diameter stock with the jaws in the normal position. The 3-1/8" 3-jaw chuck (P/N 1040) is designed to take up to 1-1/2" (38 mm) diameter stock. For larger diameter work, reverse the jaws (See Fig. 52). To prevent permanent damage, finished, turned or drawn stock should only be held with this chuck. For rough castings, etc., use a 4-jaw chuck.

Do Not Overtighten the Chuck!
Use only moderate pressure with the spindle bars (P/N 40580) supplied.

CAUTION!
Read all operating instructions carefully before attempting any machining operations.

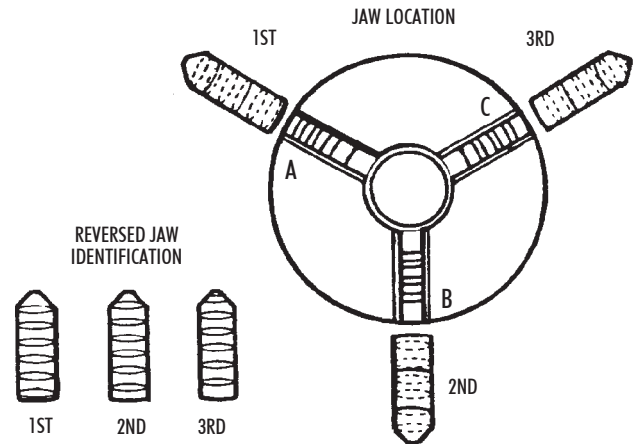

FIGURE 52—Reversing the chuck jaws.
NOTE: Always start with position "A."

To reverse the chuck jaws, rotate the knurled scroll until the jaws can be removed from the chuck body. After the jaws are removed, they can be easily identified by the location of the teeth in relation to the end of the jaws. (See Figures 51 and 52.) To maintain chuck accuracy, the 2nd jaw must always be inserted in the same slot even when the jaws are reversed. This slot is identified by the laser engraved letter "B" next to the slot. Always insert the jaws in the order and location shown on the drawings. Turn the scroll counter-clockwise when viewed from the face of the chuck until the outside start of the scroll thread is just ready to pass the slot for the first jaw. Slide the first jaw as far as possible into the slot. Turn the scroll until the first jaw is engaged.

Due to the close tolerances between the slot and jaw, the most difficult part in replacing the jaws is engaging the scroll thread and first jaw tooth without binding. Therefore, never use force when replacing the jaws, and, if binding occurs, back up the scroll slightly and wiggle the jaw until it is free to move in the slot. Advance the scroll and repeat for the second and third jaws. The scroll thread must engage the first tooth in the first, second and third jaws in order.

Removing a Stuck Chuck from the Spindle

Use one tommy bar in the hole in the spindle and another tommy bar in a hole in the chuck body to achieve enough leverage to unscrew the chuck (counter-clockwise) from the spindle thread. If the chuck becomes stuck on the spindle thread, put a tommy bar in the hole in the chuck body. Place a block of wood against the tommy bar where it enters the chuck. With a small mallet, give the block of wood a sharp tap, turning the chuck in a counter-clockwise direction. It should not be necessary to hold the spindle, as its inertia should be sufficient. (Don't hit the tommy bar anywhere other than right where it enters the chuck or you could bend it.) This small but sharp force at the outer edge of the chuck should break the thread loose and the chuck can then be unscrewed by hand.

Vertical Milling Machine Operation

NOTE: See pages 3 through 18 for setup, lubrication and general machining instructions. **Read Safety Rules for Power Tools on page 2 before operating any machine.**

General Description

At first glance, a vertical mill looks similar to a drill press,

but there are some important design differences; for example, the mill has a spindle that can take side loads as well as end loads and an accurate method of moving work in relation to the spindle on all three axes. It is wise to memorize these “X,” “Y” and “Z” axes, because, since the advent of complex electronically controlled milling machines, these terms have become common “shop talk,” even outside engineering departments. Feed screws with calibrated handwheels control movements on these three axes. The handwheel calibrations are quite accurate and should be used whenever possible.

Angles can be machined by removing the headstock alignment key and rotating the milling head to the appropriate angle to the work or by holding the work at an angle to the spindle.

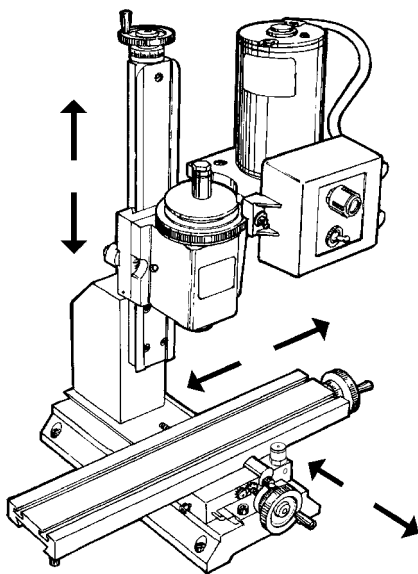

FIGURE 53—The axes of movement for milling on a standard 3-axis vertical milling machine.

(NOTE: Lighter than normal cuts should be taken when the alignment key is not in place.) The latter method must be used for drilling on 5000/5400-series mills to keep the drill movement parallel with the machine slide. Angle drilling can also be accomplished without removing the alignment key by using the optional rotary column attachment (P/N 3500). (The Model 2000 mill is also capable of angle drilling due to its multi-axis design.) All machine slides have an adjustable gib to compensate for any “play” that may develop. (See “adjusting gibs” on page 12.)

It is assumed that anyone purchasing a vertical milling machine has had some experience working with metal cutting tools; therefore, these instructions are somewhat limited for a beginner. There is enough information, however, to enable a good craftsman to get started. Using a vertical mill correctly takes more skill and experience than is required for lathe operation because of the additional axis (vertical) and the more varied type of work that can be performed.

The machine must be well maintained, for it is subject to higher stresses than a lathe. This particular mill is one of the smallest being manufactured and is an extremely useful tool. However, it would be unreasonable to clamp a 3-pound piece of stainless steel to the work table and expect to make a 1-pound part from it. The key point is to work within the capabilities of the machine, and those limitations can only be determined by the operator.

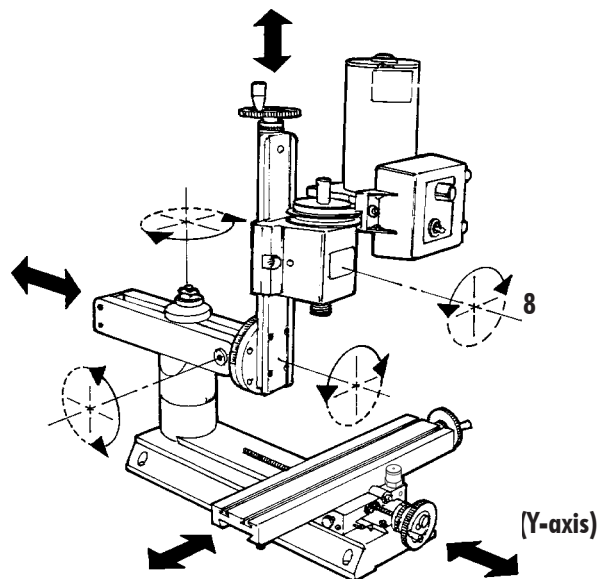

FIGURE 54—Eight directions of movement of the model 2000 series milling machines.

Helpful Tips for Milling

- This is a small, light-duty mill and should not be used to remove large amounts of stock that could be easily removed with a hacksaw. For efficiency, select a piece of stock as close to finished size as possible.
- Stresses on a mill are quite high when cutting most materials; therefore, gib and backlash adjustments must be properly maintained. (See “Adjustments” section beginning on page 11.)
- End mills must run true and be sharp. Holding end mills in a drill chuck is a poor practice. Use collets or an end mill holder instead. The 3/8" end mill holder (P/N 3079) allows you to use a large range of readily available 3/8" end mills with your machine. (Several other size inch and metric end mill holders are also available.)
- Fly cutting is an excellent way of removing stock from flat surfaces.
- Normal machine alignment is adequate for most work, but if the work is exceptionally large or requires extreme accuracy, shims may be employed to improve machine alignment.
- For accurate setups you should have and know how to use a dial indicator.
- Often, more time will be spent making fixtures to hold work than doing the actual machining.
- To help save time on many simple setups, a good mill vise is a must. A drill press vise is not designed for the forces involved in milling.
- Plan ahead. Always try to have one point from which to measure. Do not machine this point off part way through the job. This would leave you with no way of measuring the next operation.
- Remember the basic machining rule that says: “If the tool chatters, reduce speed and increase feed.”
- It takes a long time to accumulate the knowledge, tools and fixtures required for many different types of milling operations. Do not become discouraged by starting with a job that is too complex or by using materials that are extremely difficult to machine.

CAUTION! Because the tool spins on a mill, hot chips can be thrown much farther than when using a lathe. Safety glasses and proper clothing are a must for all milling operations.

Securing the Workpiece

The first problem encountered will be holding the work and aligning it to the machine. It is important for reasons of safety and accuracy that the workpiece be solidly secured. This may be the most difficult task, since once the work is clamped in position, the method of doing the entire job has been established. Usually, a rectangular block can be easily held in a mill vise. Note that round stock may also be held in a “V” shaped vise slot. Mill vises are specially designed to pull the movable jaw downward as they tighten on it. (See Mill Vise P/N 3551 shown on page 34 and in the *Sherline Tools and Accessories Catalog*.)

Certain objects can be secured with a 4-jaw lathe chuck, which is, in turn, clamped to the machine. Some irregular shapes such as castings may present greater difficulties. Often they may be clamped directly to the table. Very small or irregular shapes can be secured by epoxying them to a second, more easily held piece of material. They are broken loose after machining. A mill tooling plate (P/N 3560) is a very useful fixture for holding parts. It has a number of holes pre-drilled for holding clamps, and additional holes can be drilled and tapped as needed. It also provides additional stiffness and protection for your mill table.

Locking the Axes

To keep the table from moving in a particular direction during an operation, there is a lock available on each axis. To lock the X-axis table from moving side-to-side there is a barrel lock on the front of the saddle. (See Figure 55.) The Saddle is locked by means of a thumbscrew on the left side that presses a nylon plug against the gib to pull the saddle tight against the dovetail. The Z-axis can be locked during milling operations by means of a brass lever that tightens against the saddle nut on the back of the column. (See Figure 66, page 33.)

Things to Consider Before You Start Cutting

The following steps should be considered before commencing any part:

- Is the material about to be machined best suited for the job, and is it machinable with available cutting tools and equipment? Work with aluminum, brass, plastic or cast iron whenever possible. Too often a hobbyist will pick up the first correctly-sized piece of material he finds at his local salvage dealer thinking that, if it is rusty, it's steel, and that all steels are pretty much the same. Not so! Anyone who has ever tried to machine an old automobile axle can attest to this. If the part must be steel, grade 12L14, commonly called “lead-loy,” is about the best material for machining. It was developed for screw-machine use and is available in round stock only. However, it works so well that many times it may be advisable to machine rectangular parts from it. It can also be case hardened. Your local screw-machine shop will usually have scrap pieces available and may be a good source for obtaining it.
- Avoid exotic materials, such as stainless steel, unless absolutely necessary because of machining difficulty and poor milling cutter life. (If each new mechanical engineer were given a block of stainless steel to mill, drill and tap upon his graduation, stainless steel sales would probably drop considerably!)

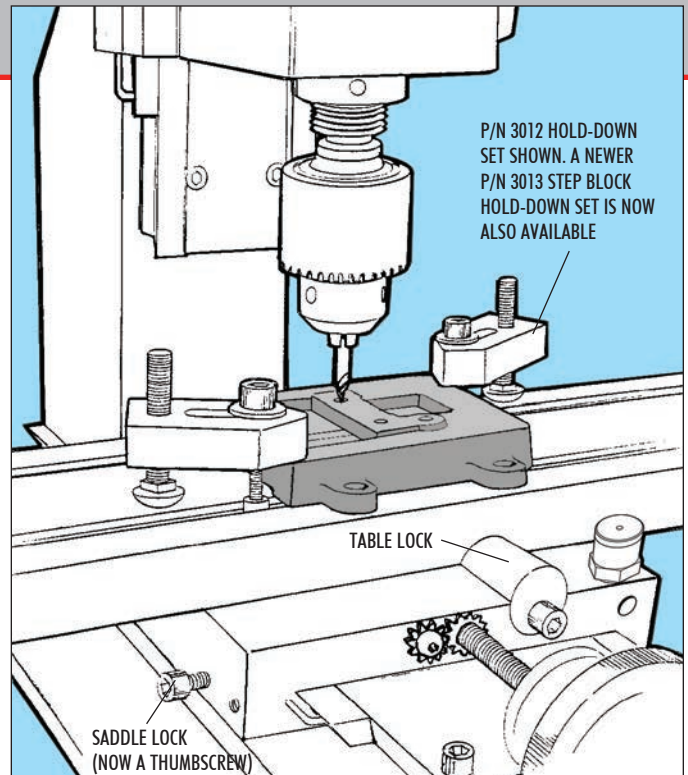

FIGURE 55—Large or odd shaped parts are usually clamped to the mill table as shown here. Smaller parts can be held in a milling vise. Here a center drill is used to accurately locate the holes to be drilled in a clamped part.

- Before beginning, carefully study the part to be machined. Select the best surface from which to work (usually the flattest).
- Decide if work should be “rough cut” to size. Some materials will warp while being machined. Close tolerance parts can be ruined by attempting heavy machining at the end of the job rather than at the beginning.
- The method of holding the work is also determined by the type of machining to be performed. For instance, work that involves only small drilling jobs does not have to be held as securely as work to be milled.
- Lay the job out so that it can be machined with the minimum number of setups.
- Be sure to have all needed cutting tools available before beginning a job.
- Do not start off with a job so complex that the odds of success are limited. Making complex machined parts requires a great deal of intelligence, planning and skill. Skill is acquired only through experience.

In summary, you should be aware of the fact that milling is difficult, but not impossible. There are many more considerations than just moving the handwheels, and you should not start your first step until your last step has been determined.

Purchasing Materials in Small Quantities

Commercial metal suppliers are not set up to serve the home shop machinist. They usually have large minimum order quantities and high “cutting charge” fees that make it impractical to purchase small amounts from them. However, there are now a number of suppliers that cater to the hobby market. They have complete catalogs of the materials most commonly used by hobbyists, and you can order as much or as

little as you need. The price per inch is somewhat higher than industrial rates, but the convenience and overall savings make it well worth it. There are several suppliers listed on Sherline's website. Your local scrap yard can also be a good source for raw materials at good prices. Bring your own hacksaw, and be aware that the some yards are better than others at identifying and organizing the materials. If you are not sure exactly what kind of metal you are getting, you could be letting yourself in for a lot of trouble when you start cutting. See sherline.com/raw-materials/ for a list of sources for obtaining raw material in small quantities.

Three Types of Work

There are three basic types of work that can be performed with a vertical milling machine: milling, drilling and boring. It would be extremely difficult to determine whether a vertical mill or a lathe would be the most valuable machine in a shop. Theoretically, most vertical mills are capable of reproducing themselves with standard milling accessories such as a rotary table and centers. This would be impossible on a lathe without exotic modifications and attachments. These instructions briefly describe standard vertical mill work. Several comprehensive books are available on this subject, and, although the machines they describe are much larger, the principles remain the same. A good starting point is a book we offer called *Tabletop Machining*. It is printed in full color and is available through Sherline as P/N 5301. Sherline tools are used throughout in all the setups and examples.

Types of Milling Cutters

Milling on a vertical mill is usually accomplished with end mills. These cutters are designed to cut with both their side and end. (See Figure 64, Page 32.) Drilling is accomplished by raising and lowering the entire milling head with the Z-axis feed screw. Center drills must be used before drilling to achieve any degree of accuracy. (See Figures 55 and 70.) **Note** that subsequent holes may be accurately "dialed in" from the first hole by using the calibrated handwheels. Each revolution of the wheel will yield .050" of travel or 1mm for the metric machines. There is no need to start with the handwheel at "zero," although this can be easily accomplished with the optional resettable "zero" handwheels to make calculations easier.

Boring is a method of making accurate holes by rotating a tool with a single cutting edge, usually in an adjustable holder called a "boring head." It is used to open up drilled holes or tubing to a desired diameter. (See Figure 57.)

Another type of milling is performed with an adjustable fly cutter, which may be used for surfacing. For maximum safety and rigidity, the cutting bit should project from the holder no further than necessary. A 1-1/2" diameter circle of cut is quite efficient, and multiple passes over a surface should overlap about 1/3 of the circle size. For machining aluminum, use a speed of 2000 RPM and remove about .010" (0.25 mm) per pass. (See Figure 68 on page 34.)

Standard Milling Versus Climb Milling

It is important to understand that the cutting action of a milling cutter varies depending upon the direction of feed. Study the relationship of cutting edges to the material being cut as shown in Figure 57. Note that in one case the tool will tend to climb onto the work, whereas in the other case the tool will tend to move away from the cut. The result is that climb milling should normally be avoided except for very light finishing cuts.

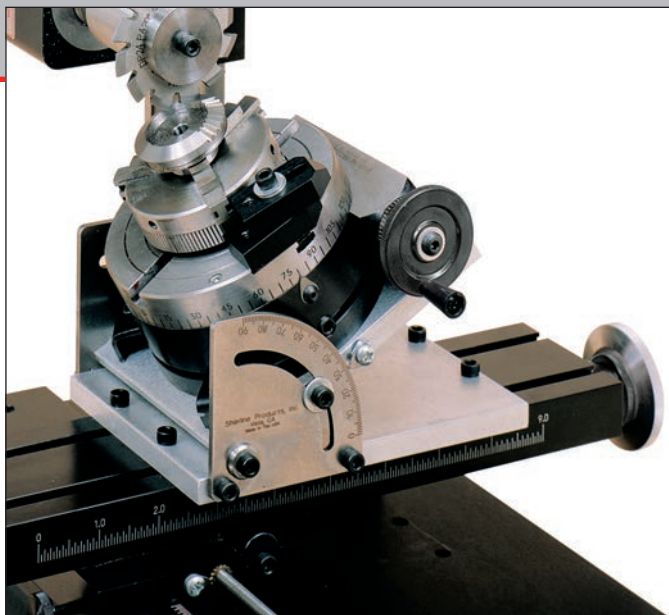

FIGURE 56—A complex setup shows a part held in a 3-jaw chuck, which is mounted to the rotary table, which is mounted to the tilting angle table, which is in turn mounted to the mill table. A mill arbor holds a gear-tooth cutter which is cutting teeth in a bevel gear. The horizontal milling conversion is used to mount the headstock in the horizontal position. With Sherline tools and accessories, the parts you machine are limited only by size, not by complexity.

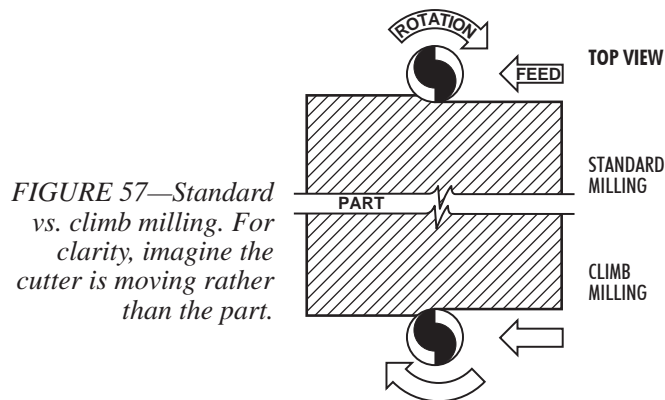

FIGURE 57—Standard vs. climb milling. For clarity, imagine the cutter is moving rather than the part.

Climb Milling Advantages and Drawbacks

Though you will almost always use conventional milling, climb milling can create a better finish in two ways. First, the lightest part of the cut is at the end of the cut. Second, the chips are tossed from the cutting area and do not affect the finish.

The major problem with machining in this direction is that the cutter may actually do just that—climb up on the part and break. Also, when a climb cut is first started, the work has to be pushed into the cutter. Then the cutting action pulls the backlash out of the table leadscrew, and a heavier cut is taken than planned. If you understand and compensate for these drawbacks, climb milling can be used. However, for those new to milling, it is best to try and plan your cuts so that the end mill is cutting in the conventional manner.

Working to Scribed Layout Lines

A common practice when working with a mill is to lay out the hole centers and other key locations using a height gauge and a surface plate. A coloring (usually deep blue) called layout fluid or "Dykem" is brushed or sprayed on a clean surface of the part. A thin layer is best because it dries quicker and

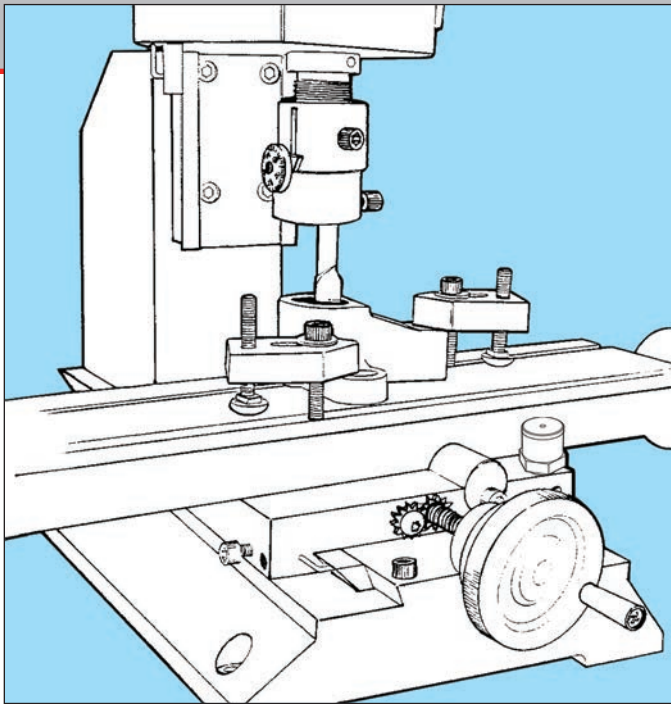

FIGURE 58— Boring the inside of a hole to exact size with a boring tool held in a boring head.

won't chip when a line is scribed. The purpose of this fluid is to highlight the scribed line and make it easier to see.

Don't prick-punch the scribed, crossed lines representing a hole center. Using a center drill in the mill spindle and a magnifying glass, bring the headstock down until the center drill just barely touches the scribed cross. Examine the mark left with a magnifying glass and make any corrections needed to get it perfectly on center. You should be able to locate the spindle within .002" (.05 mm) of the center using this method.

Once the first hole is located in this manner, the additional holes can be located using the handwheels. (This is where the optional resettable "zero" handwheels are useful.) Now the scribe marks are used as a double check and the handwheels take care of the accuracy. Don't forget the rules of backlash—always turn the handwheels in the same direction as you go from one point to the next.

Using a Dial Indicator

(NOTE: For more on use of a dial indicator to square up your mill, see pages 13-16.)

The basis of most accurate machining involves the use of a "universal dial test indicator"; a small, inexpensive indicator which is calibrated in .001" or .01 mm divisions. An indicator with a large face or one that reads in finer divisions is not necessary for use with this mill. Three major tasks that can be accomplished with an indicator are:

1. Checking the squareness of a setup.
2. Finding the center of a hole.
3. Aligning the work with the machine.

A vise can be mounted or a part can be clamped down exactly parallel with the machine slides by holding the test indicator stationary and moving the slide with which you wish to align the part. When "indicating in" a vise, always take the reading on the fixed jaw. To start with, use approximately .005" indicator deflection from neutral. Remember that excessive pressure can cause inaccurate readings. Also, try to keep the indicator finger at a reasonable angle to the indicated part or

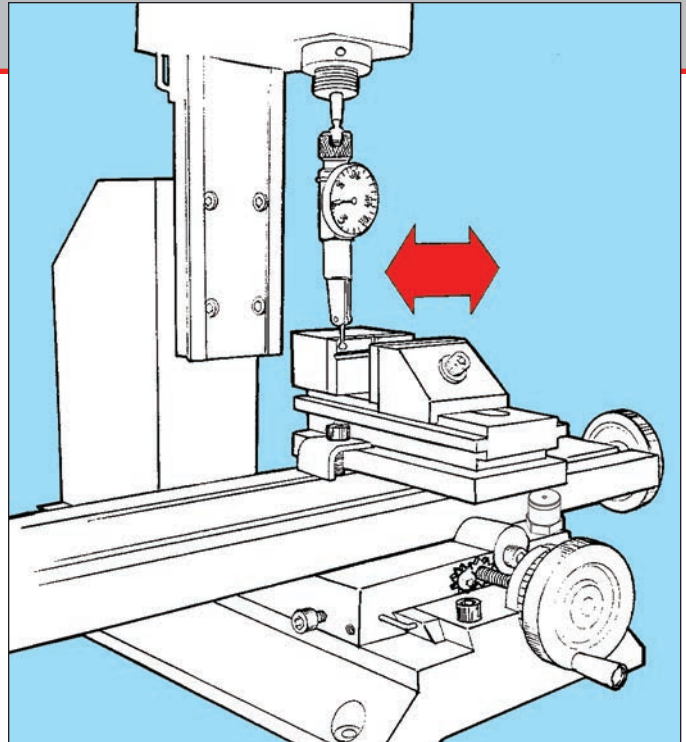

FIGURE 59— Indicating in the jaws of a vise. Shown is a Starrett "Last Word" Indicator. Starrett gauges are available in numerous sizes and types. They are manufactured in Athol, Massachusetts and can be purchased from most industrial dealers.

surface. When the part is properly aligned, there will not be any deflection on the indicator. If you wish to locate the spindle over an existing hole, place the indicator in the spindle and read the inside surface. Move the X- and Y-axes until there is no deflection when the spindle is rotated. At this point, the spindle is in perfect alignment with the hole's center.

When aligning the spindle to used bearing holes, remember that the hole may be worn out-of-round, and it may be impossible to attain zero indicator deflection reading. Boring out a worn bearing hole to a larger diameter and sleeving it with a simple bushing made on a lathe is a fairly common machining operation. With the new bushing pressed in, the bearing will be like new.

The squareness of your machine may also be checked with an indicator. For instance, alignment of the head can be checked by offsetting the indicator in the spindle so the tip will move on about a 3" to 5" diameter circle. The amount of reading relative to the table is the amount of error. Don't be discouraged to find a few thousandths of an inch error in your machine. This machine has been designed to have the most accuracy commensurate with reasonable cost. In machine tool manufacturing, accuracy and cost run hand-in-hand. To increase accuracy only a few percentage points could double the selling price, because entirely different manufacturing processes would be required. However, you can personally improve the accuracy of your machine with a few shims, if needed, by employing your dial indicator.

The column bed is aligned with the column block at the factory. If you remove the block, it will have to be realigned by mounting a known "square" on the mill table and adjusting placement of the bed by running an indicator on the square as the headstock is raised and lowered. (See Figure 29, page 16.) The same method can be used to check alignment of the column bed to ensure it is square with the Y-axis. To correct

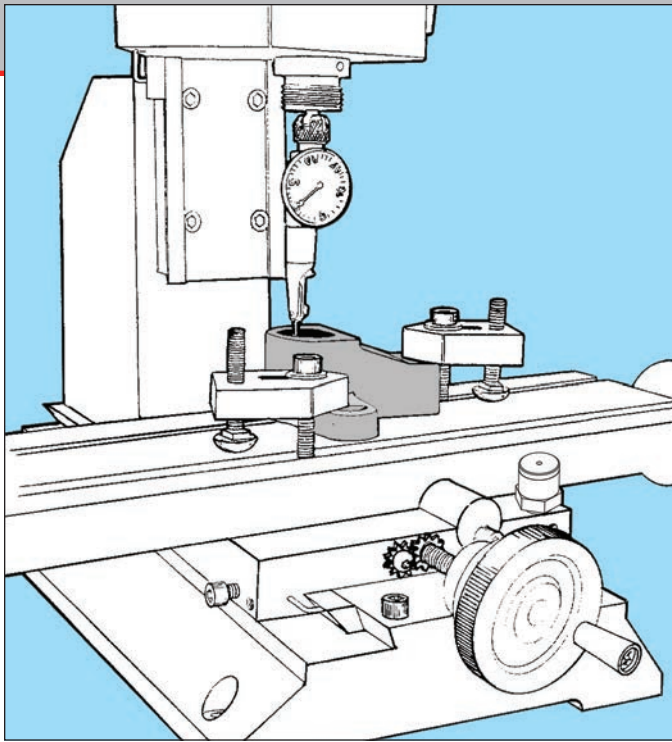

FIGURE 60—Indicating in the center of a hole.

any error (which should be small), place a shim between the column block and the mill base.

Locating the Edge of a Part in Relation to the Spindle

There are two quick methods of “picking up an edge” of a part on a mill. The first is to put a shaft of known diameter in the spindle and see that it runs perfectly true. Using a depth micrometer against the edge of the part, measure the distance to the outside diameter of the shaft. To that dimension add half the known shaft diameter. You now have the distance from the edge of the part to the centerline of the spindle. Rotate the handwheel on the axis being set exactly this distance and you will have the centerline of the spindle lined up with the edge of the part from which you measured.

The second method is much easier. It involves the use of a clever tool called an “edge finder.” These devices have been around for years and have two lapped surfaces held together by a spring. One surface is on the end of a shaft that fits in a 3/8" end mill holder and is held in the spindle. The other is a .200" diameter shaft held to the larger shaft with a spring so it is free to slide around. With the spindle running at approximately 2000 RPM, the shorter shaft will be running way off center. As this shaft is brought into contact with the edge you are trying to locate in relation to the spindle, the .200" shaft will be tapped to the center as the spindle rotates. This keeps making the .200" shaft run continually truer. When the shaft runs perfectly true it makes contact with the part 100% of the time. This creates a drag on the surface of the shaft that will “kick” it off center. (See Figure 61.) At this point you know the part is exactly .100" (half

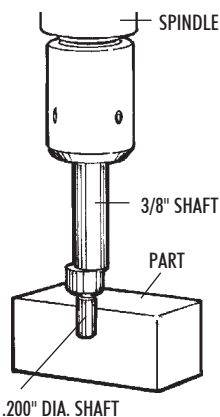

FIGURE 61—Using an “edge finder” to accurately locate the edge of a part.

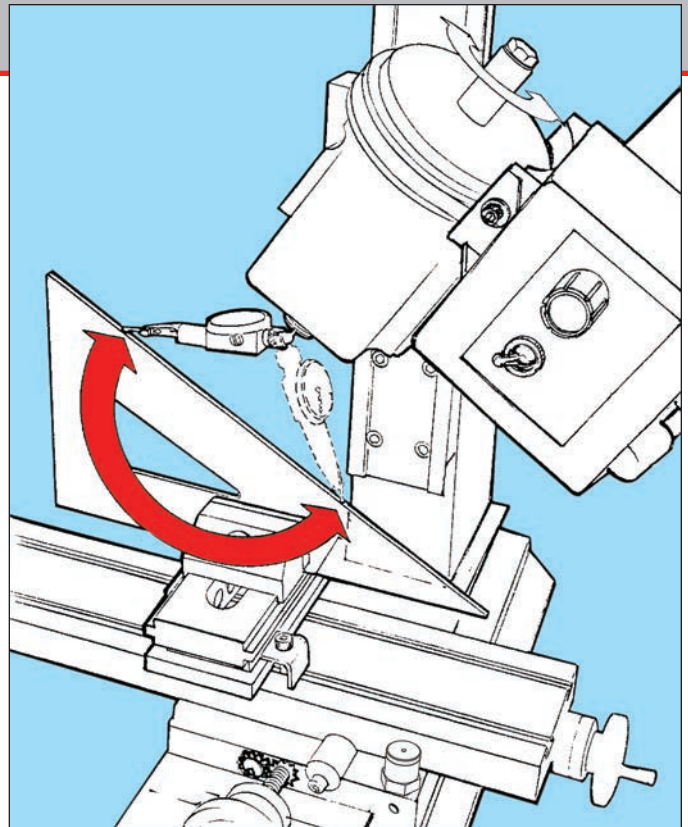

FIGURE 62—Indicating in a 30° head tilt using a mill vise and draftsman’s triangle

the diameter) from the centerline of the spindle. Advancing the handwheel on a Sherline mill two revolutions (.050" per revolution) will bring the edge of the part into alignment with the spindle.

It is important to use a high quality edge finder such as the Starrett 827A shown in the drawing. It must have a 3/8" shaft to fit the end mill holder on the Sherline mill. Metric sized edge finders are also available which work in the same manner.

For those who like to own the newest gadgets, electronic edge finders are now available. Import models are available for less than \$100.00.

Determining the Depth of Cut

There are no firm rules other than common sense for determining depth of cut. A .030" cut depth with a 3/16" end mill in aluminum could be considered light, but .003" cut depth in steel with a 1/32" diameter end mill would break the cutter. Start with very light cuts and gradually increase the depth until satisfactory results are achieved. Try to develop the skill of knowing how much of a cut is satisfactory without breaking the cutter or damaging the work.

Note that regular end mills should not be used for drilling, however, they may be employed to enlarge an existing hole. The cutting edges deserve more respect than those of drills even though similar in appearance; they are designed to cut with their sides. Handle and store them with care.

Work Accurately

It should be remembered that a good machinist is capable of making a part to much closer tolerances than those of the machine with which he is working. The accuracy of the parts you make is limited only by your skill as a craftsman and the quality of your measurement equipment. Accuracy should be the ultimate goal of every machinist!

Cutting Speeds for Milling

Speed Adjustment Chart	
SPINDLE RPM =	$\frac{3.82 \times \text{S.F.M.}}{D}$
S.F.M. =	The rated Surface Feet per Minute for milling. For drilling, use 60% of the rated surface feet.
RPM =	The rated spindle speed in Revolutions Per Minute
D =	The Diameter of work in inches

FIGURE 63—Formula for adjusting spindle speed for cutting a given diameter.

NOTE: To estimate RPM, remember that the speed range of your vertical mill is from 0 to 2800 RPM. (The lowest usable speed is about 70 RPM, so we use that in our specifications. To obtain much more torque at the lower speed ranges, the drive belt can be switched to the smaller diameter positions on the spindle and drive pulleys.) Therefore, in the normal belt position, half speed is approximately 1450 RPM and so on. You can estimate these speeds by a combination of the setting on the speed control knob and the sound of the motor itself. When using the optional digital readout (P/N 8100), the exact RPM is displayed constantly on the LCD screen.

End Mills

End mills are the standard cutting tools used on a vertical mill. We recommend 3/8" shank end mills held in the 3/8" end mill holder (P/N 3079). One of the benefits of 3/8" end mills is that they are available in a large range of sizes. The end mill is held with a set screw on its flat surface, and it can be easily changed. They are also lower in price than miniature cutters because of their popularity.



FIGURE 64—4- and 2-flute double-ended end mill sets.

You can also use miniature series end mills having 3/16" or 1/4" shank sizes which should be held in collets or end mill holders sized for those tools. Many "Dremel[®]" type cutting tools come with a 1/8" shank. End mills held in collets must be

single-ended, while end mill holders are capable of holding single- or double-ended end mills. We recommend using 2-flute, high-speed steel (HSS) end mills for aluminum because the flutes are less prone to clog with chips. Use 4-flute cutters for cutting steels with lower RPM. The solid carbide tools are not suggested since they are very expensive and the cutting edges will chip unless used with heavy-duty production equipment.

As a convenience to our customers, Sherline keeps in inventory many of the popular sizes of end mills that are appropriate for use on our machines. See our "Cutting Tools Price List" for selection. End mills may also be purchased on-line or from your local industrial machine shop supply outlet. Do a search for or see the yellow pages under "Machine Shop Supplies." Because small diameter cutters (less than 1/8") are quite fragile, the largest diameter cutter possible for the job requirements

END MILLS (Slot and side milling)

MATERIAL	CUT SPEED (S.F.M.)	1/8" DIA.	1/4" DIA.	3/8" DIA.
Stainless Steel, 303	40	1200 RPM	600 RPM	400 RPM
Stainless Steel, 304	36	1100	500	350
Stainless Steel, 316	30	900	450	300
Steel, 12L14	67	2000	1000	650
Steel, 1018	34	1000	500	350
Steel, 4130	27	800	400	250
Gray Cast Iron	34	1000	500	350
Aluminum, 7075	300	2800	2500	2000
Aluminum, 6061	280	2800	2500	2000
Aluminum, 2024	200	2800	2500	2000
Aluminum, Cast	134	2800	2000	1300
Brass	400	2800	2800	2800

DRILLS

MATERIAL	CUT SPEED (S.F.M.)	1/16" DIA.	1/4" DIA.
Carbon Steel	36	2000 RPM	550 RPM
Cast Iron, Soft	30	1800	450
Stainless Steel	24	1400	360
Copper	72	2000	1100
Aluminum, Bar	240	2000	2000
Aluminum, Cast	120	2000	2000

FIGURE 65—Drill and milling cutter speed chart.

should be employed. Be certain that the RPM is appropriate before attempting to remove any metal. An end mill can be instantly damaged if a cut is attempted at excessive RPM. Like all cutting tools, end mills will have a short life span when used for machining steel or other exotic materials. Save new cutters for finish work. Because of excessive cutter deflection (bending), do not use small diameter end mills with long flutes unless absolutely necessary.

Resharpener End Mills

End mills can be resharpened by your local tool and cutter grinding shop. End mills lose their cutting edge clearance after a couple of sharpenings and should no longer be reused.

Using the Mill Column Saddle Lock

The saddle locking lever is located on the back side of the mill column just above the saddle nut. This lever tightens against the saddle nut on the column leadscrew to keep it from moving during milling operations.

With the lever released, adjust the Z-axis handwheel to the desired setting. Rotate the lever counter-clockwise to lock the saddle. This will eliminate any backlash in the leadscrew. Friction on the gib can still cause a little backlash to be present between the handwheel and the leadscrew thrust. To eliminate this, push down on the saddle to make sure the handwheel is fully seated against the thrust. Double check your height adjustment. Now, when milling, the saddle cannot move any further down.

To release the saddle, rotate the lever clockwise. A spring-loaded ball in the saddle fits in a detent on the lever to keep it from locking accidentally when the Z-axis is adjusted. (See Figure 66.)

An adjustable saddle lock is available that allows adjustment of backlash on the Z-axis. This is particularly useful in CNC applications but can be used on manual machines as well. It is standard on new CNC machines and available as an upgrade for manual machines as P/N 4017Z/4117Z.

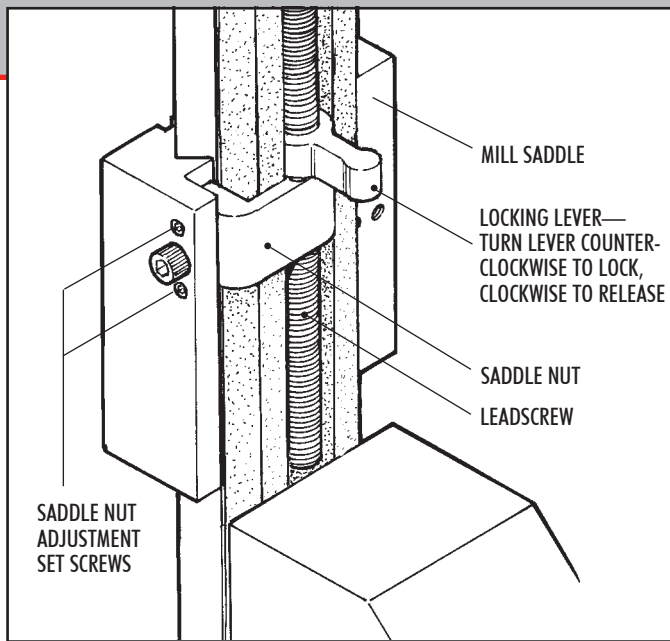

FIGURE 66—Mill column saddle lock

Machining Tip

Use of a tooling plate (P/N 3560) is an inexpensive way to protect the surface of your mill table while providing a flat, versatile clamping surface with a pre-drilled pattern of tapped holes for mounting parts and fixtures. The additional thickness also adds rigidity to the mill table. A round tooling plate is also available for the rotary table (P/N 3725).

Accessories for Your Milling Machine

The addition of accessories can greatly enhance the utility of your mill. A few of the more popular milling accessories and how they are used are described below.

Sensitive Drill Attachment (P/N 1012)



The sensitive drilling attachment provides both faster drilling of multiple holes and better “feel” for the cut when using drills smaller than 1/16". This is essential to keep from breaking tiny drill bits that can be quite expensive. A Jacobs 5/32" drill chuck is fitted to a spring-loaded shaft that inserts into the spindle. A red knurled collar with a ball bearing at the center, allows the user to hand feed the chuck. A spring inside the brass tube helps return the chuck to the up position when done. The chuck holds drills from 5/32" (4 mm) down to much smaller sizes. The attachment is easily installed by screwing it onto the external 3/4-16 thread of the spindle.

3/8" End Mill Holder (P/N 3079)

The 3/8" end mill holder makes it easy to use the popular (and less expensive) 3/8" end mills. Using double-ended end mills is economical and easy with this holder, as tools are changed by simply loosening a set screw and changing



the tool. Sherline now offers similar holders for other size cutting tools as well. For CNC use, these holders allow for quick tool changes and unlike when using collets, the cutter length does not change. The following additional sizes are available: 1/8" (P/N 6081), 3/16"

(P/N 6080), 1/4" (P/N 6079), 5/16" (P/N 3075), 6.0 mm (P/N 3076), 8.0 mm (P/N 3077) and 10 mm (P/N 3078).

Drill Chuck Holder (P/N 3074)



In order to allow for a quick way to change chucks, a similar holder with a 3/8-24 threaded boss on the end instead of a hole is now available. This allows 1/4" and 3/8" Jacobs drill chucks to be threaded onto

a holder and changed quickly. During CNC operations this also means drills can be changed without having to change the tool length in the “tools” table.

Mill Collet Set (P/N 3060)



The main purpose of the mill collet set is to hold single-ended end mills accurately on center. The spindle nose has an internal Morse #1 taper that closes the collet as the drawbolt is tightened.

Mill collets are available individually or in sets of the three most common sizes with a drawbolt included.

Boring Head (P/N 3054/3049)

The main purpose of the boring head is to eliminate the need for a large inventory of drills and reamers. A small milling machine would not have the power or rigidity to turn a one-inch diameter drill even if one could be obtained that would

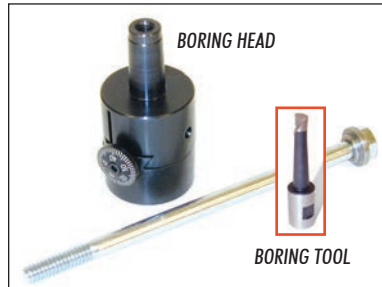

fit. However, holes of up to 1-3/4" (44 mm) can be accurately bored to size with a little patience and care.

Boring heads for the mill work on the same cutting principle as lathe boring, except that the cutting tool turns while the work remains stationary. (In

the case of a lathe, the work turns and the cutter remains stationary.) The boring head is designed to employ round cutting tools with a 3/8" shank. Sherline offers three boring tools with sizes and lengths appropriate for the Sherline mill. It is sometimes advisable to remove excessive tool shank length from standard (non-Sherline) 3/8" boring tools in order to improve rigidity. (See Figure 58, page 30 for a boring tool in use.)

Tool sizes are listed indicating the smallest diameter hole that can be bored and the maximum depth that can be cut. For best results, use the largest diameter possible with the shortest lengths. A .010" cut represents a good starting point.

If boring a hole where a flat bottom is required, it is advisable to stop the down-feed at about .002" above the desired depth, turn off the motor and cut the remaining distance by hand-turning the spindle to eliminate any possibility of chatter.

Boring Tools Available—3/8" diameter shanks

P/N 3061—Min. hole size: 1/4" (6.4 mm), Max. depth: 0.6" (15 mm.)

P/N 3063—Min. hole size: 5/16" (7.9 mm), Max. depth: 1.0" (25 mm)

P/N 3064—Min. hole size: 5/16" (7.9 mm), Max. depth: 1.5" (38.1 mm)

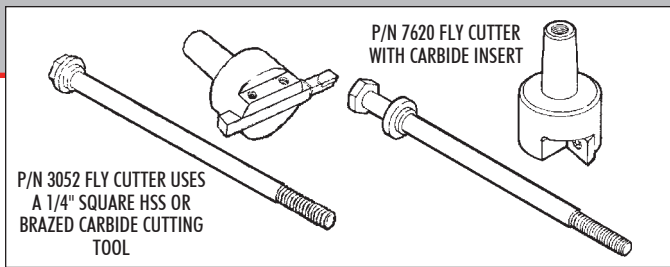

FIGURE 67—Fly cutters and drawbolts

Fly Cutters (P/N 3052 and P/N 7620)

For machining flat surfaces, fly cutters are recommended. It is imperative that the tool be used with utmost care. EYE PROTECTION IS A MUST, and the work as well as the cutting tool must be properly held. The big advantage of a fly cutter is its ability to take light cuts up to 2" wide and to give an excellent surface finish. It is ideal for squaring up work. Also, the machining stresses are lower than one might imagine, because, unlike an end mill, very little crushing action takes place at the cutting edge. Fly cutting tools look like left-hand lathe tools, and, although the fly cutter (P/N 3052) comes with a brazed carbide tool, high-speed tools work quite well and can be sharpened on any grinder. (See Figures 68 and 69.)

Drill Chucks (P/N 3072) and Center Drills

The 1/4" drill chuck available for this vertical mill is supplied complete with a #1 Morse arbor and a drawbolt to hold it securely in place. Drilling can be accomplished by raising and lowering the entire head with the vertical feed handwheel. This allows for very accurate control of feed rate and hole depth. For accurately located holes we again stress the importance of using center drills.

Drills should be kept in excellent condition, either by replacement or proper resharpening. Good quality high-speed steel drills should be employed. A dull or improperly sharpened drill can cut oversize by as much as 10%. When you start to drill, the initial penetration should be no more than twice the diameter of the hole before you retract the drill, clear the chips and add coolant with the tip of a small brush. From then on, do not try to drill deeper than the diameter of the drill without clearing the chips and adding coolant. For example:

To drill a 1/8" diameter hole 1" deep:	Total Depth
1st Pass: 2 times diameter or 1/4"	1/4"
2nd Pass: 1 times diameter or 1/8"	3/8"
3rd Pass: 1 times diameter or 1/8"	1/2"
Etc.	

(You may encounter recommendations exceeding this, but they are meant for automatic equipment with pressurized coolant systems.)

It is difficult to maintain tolerances of better than +.003"–.000" with a drill. If tolerances closer than these are required, a reamer must be employed. Try to use fractional size reamers whenever possible rather than decimal sizes, because the cost difference can amount to 2 or 3 times higher for decimal sizes. (The length of reamers may prevent their use for some operations on machines of this size.)

Center Drills

To accurately start holes, center drills must be used. They have a small tip that accurately starts the hole, and then the shaft widens with a 60° cutting face to the final diameter. Care must be taken to employ cutting oil and to clear chips from the drill frequently. If this is not done, the fragile tip

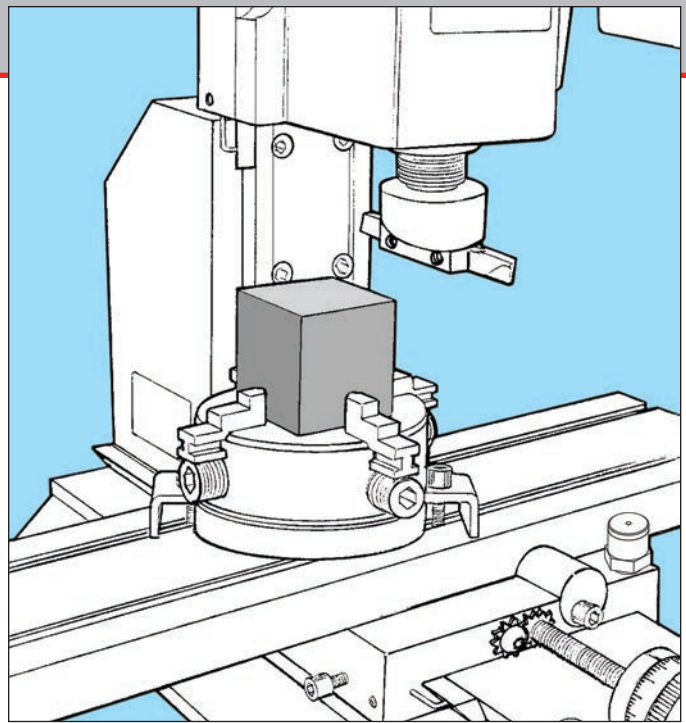

FIGURE 68—Typical setup for fly cutting.

may load up and twist off, even in soft materials. Center drills are available in a variety of sizes, but for general work we recommend size No. 1.



FIGURE 69—Three center drills in the P/N 3021 set.

SIZE	BODY DIA.	DRILL DIA.	DRILL LENGTH	LENGTH OVERALL
000	1/8"	.020"	.020"	1-1/4"
00	1/8	.025	.025	1-1/4
0	1/8	1/32	1/32	1-1/4
1	1/8	3/64	3/64	1-1/4
2	3/16	5/64	5/64	1-7/8
3	1/4	7/64	7/64	2

FIGURE 70—Table of common HSS center drill sizes.

Mill Vise Set (P/N 3551)

The vise shown here and in use in Figures 59 and 62 is furnished with special clamps that allow it to be clamped in any position on the mill table. The vise capacity is 2 inches. It has a movable jaw that is pulled down while clamping, eliminating any chance for the jaw

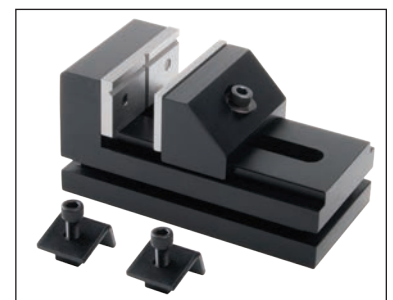

to lift. Perpendicular grooves in the fixed jaw help secure round stock. It is the most convenient way to hold small parts for milling. Also available for the mill vise is a rotating base (P/N 3570) that greatly adds to the versatility of this basic machining accessory.

Tilting Angle Table (P/N 3750)

This accessory opens up a great variety of setup options. The table can be tilted to any angle from 0° to 90°. A hole pattern in the table is designed to easily mount the mill vise or rotary table for holding parts. A chuck adapter is included that allows the 3-jaw or 4-jaw chuck to be screwed directly to the table as well. Parts mounted to the table can be machined or drilled at precise angles without tilting the column or headstock. In the 90° position, the rotary table is held at the same height as it would be on the P/N 3701 right angle plate, eliminating the need for that accessory.



A hole pattern in the table is designed to easily mount the mill vise or rotary table for holding parts. A chuck adapter is included that allows the 3-jaw or 4-jaw chuck to be screwed directly to the table as well. Parts mounted to the table can be machined or drilled at precise angles without tilting the column or headstock. In the 90° position, the rotary table is held at the same height as it would be on the P/N 3701 right angle plate, eliminating the need for that accessory.

Horizontal Milling Conversion (P/N 6100) for 5000/5400-Series Mills

A number of milling operations require the application of the cutting tool from the side rather than from the top. A 3/4" thick aluminum base 10.5" x 12.5" allows a 5000/5400-series mill column to be mounted separately from the base for a variety of milling configurations. The headstock is rotated 90° and work is machined from the side, allowing larger surfaces to be worked on without having to re-clamp the work. (NOTE: The greater versatility and capacity of the 2000-series 8-direction mill eliminate the need for this accessory on those mills.)

The black anodized mounting plate is pre-drilled to mount the base and column in several possible locations. Alignment bars and a selection of appropriate bolts are included to make it easy to accurately relocate the column. Rubber feet insulate the table for quiet, vibration-free operation. (NOTE: The column base should be shortened by 2" for best operation. Instructions are provided with the accessory, or we can shorten your column for you. The modification is listed as P/N 6101 on the price list. New mills purchased along with the horizontal milling conversion can be factory ordered with the column already split.)



FIGURE 71—One of the configurations possible with the horizontal milling conversion, P/N 6100.

5400 Mill Column Base with 2000 Ram (P/N 5640 Short, P/N 5645 Tall)

These rigid columns are designed for those who have a 5400-series mill. Each comes with the 2000-series ram and gives the versatility of Sherline's 2000-series mill column with its large work area and seven directions of movement. The tall column provides more Z-clearance.

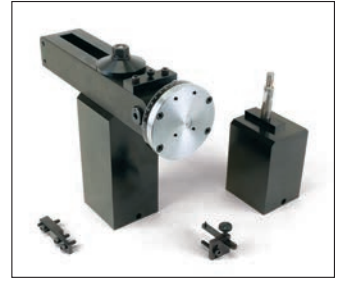

Rigid Mill Column Bases for 2000 Mills (P/N 5605 Short, P/N 5606 Tall)

For those who want the versatility of Sherline's 2000/2010 mill column with its large work area and multiple directions of movement but have experienced unwanted column rotation during extreme machining loads on the 2000 mill, this new column offers another option.



The one-piece column absolutely prevents that from happening, although you do give up the ability to rotate the column ram from side-to-side.

4" Rotary Table (P/N 3700)

The rotary table mounts to the mill table and provides a rotary axis for milling. Each increment on the handwheel represents 1/10° of rotation, so a circle can be divided into 3600 segments without interpolation. Seventy-two handwheel revolutions rotate the table one time. It can be used to mill a radius on a part, cut a circular slot or drill precision circular hole patterns. Used with the right angle attachment (P/N 3701) and right angle tailstock (P/N 3702), it can also be used to cut gear teeth. A rotary table used with a mill allows a machinist to produce virtually any part he can design. On a Sherline mill, the only limits are size, not complexity. The compact size of this high quality rotary table also makes it a good choice for use on larger machines as well, where its size would offer an advantage in working with small parts. (See Figure 56 for a photo of the rotary table in use.)



Used with the right angle attachment (P/N 3701) and right angle tailstock (P/N 3702), it can also be used to cut gear teeth. A rotary table used with a mill allows a machinist to produce virtually any part he can design. On a Sherline mill, the only limits are size, not complexity. The compact size of this high quality rotary table also makes it a good choice for use on larger machines as well, where its size would offer an advantage in working with small parts. (See Figure 56 for a photo of the rotary table in use.)

CNC Rotary Tables

The rotary table can also be purchased in CNC-ready form with a stepper motor mount attached ready to accept a NEMA 23 size stepper motor of your choice. The CNC-ready table is P/N 3700-CNC. If you prefer to purchase a rotary table with a Sherline stepper motor already attached it is P/N 8730. The motor is pre-wired with a 5-pin plug that is ready to plug in to the Sherline driver box (P/N 8760) and go to work as the 4th axis of your CNC mill system.



To view or print complete instructions for all Sherline accessories, see sherline.com/product-information/sherline-accessory-instructions/.

CNC Rotary Indexer (P/N 8700)

This completely self-contained, programmable unit is perfect for repetitive radial operations like gear cutting, drilling multiple hole patterns, cutting splines on a shaft or spokes in a wheel. Using the keypad, you enter the parameters such as the number of divisions or degrees of rotation required, speed and direction of rotation. When the command is given, the indexer will move precisely to the next programmed position. The computer keeps track of the divisions to many decimal places, so error is virtually eliminated. Backlash can also be accounted for electronically if a direction change is required. The unit includes a programmable keypad unit, rotary table, motor mount, stepper motor, power supply and all connecting cables. It can also be “daisy chained” with other rotary or linear units to produce sequenced operations.

A linear version of this same keypad and motor unit is available that functions like a power feed on any axis of the lathe or mill. Various kits are available with motor mount, keypad and stepper motor to convert any mill axis from manual to stepper motor driven. The motor and keypad unit is P/N 8800. If you need to install a motor mount in place of a handwheel, the P/N 8850 kit includes the mount, motor, keypad, power supply and everything you need to convert either the X or Y axis of the mill. Other kits are available for the Z axis or for the lathe leadscrew or crosslide.



FIGURE 72—This simple programmable indexer brings computer control to operations like cutting gears.

CNC and CNC-Ready Sherline Lathes and Milling Machines

Computer Numeric Control (CNC) is the way most machine tools are run in the modern machine shop. As more people have learned the advantages of using CNC and costs have come down, it has become more popular in the home shop as well. Therefore, Sherline now offers you several options. Any existing Sherline lathe or mill can be purchased in any one of three configurations:

1. **MANUAL**—Any standard machine can be converted to CNC later with the purchase of a CNC upgrade kit.
2. **CNC-READY**—These machines come with stepper motor mounts on all axes ready for the application of stepper motors. You can use our P/N 8760 4-axis driver box, our stepper motors and your own computer running either our Linux/EMC2 G-code software (included with driver box) or Windows® based software you purchase elsewhere. (**NOTE:** These machines cannot be operated manually until stepper motors with dual shafts are installed.)

FIGURE 73—P/N 8020 CNC system includes 2000 mill, motors, computer and software.



3. **FULL CNC**—These CNC packages include a mill with three stepper motor mounts or a lathe with two stepper motor mounts, the appropriate number of stepper motors, a new computer with a built-in, 4-axis driver box (includes keyboard, mouse, and all necessary cables to connect it, but not a monitor), a Linux operating system and the LinuxCNC G-code control program installed in the computer (formerly known as EMC2). With handwheels mounted to the rear motor shafts, the operator has the choice of manual or CNC operation.

Of course, no matter how you order your machine in relation to CNC, all machines are still available in your choice of metric or inch leadscrews and any of the accessory packages can also be ordered with the machine itself.

Learning about CNC

CNC means instead of you turning the handwheels directly, you are giving a computer instructions to turn the handwheels for you. The language the computer uses to communicate with the machine is called “G-code.” G-code is a simple text-based language where each line of code tells each axis of the machine where to go next. A driver box converts these instructions into signals the stepper motors understand, and they move the various axes for you. A stepper motor accurately divides a single rotation into several hundred steps, providing a predictable and repeatable method of precisely moving the table when the appropriate number of pulses are sent to it from the driver box.

G-code can be written directly by you, or for more complicated 2D curves or 3D shapes, it can be translated from a CAD (Computer Aided Drafting) file using a utility program, or it can be output from a CAM (Computer Aided Manufacturing) program as part of a CAD/CAM package. Sherline does not promote one CAD or CAD/CAM system over another, and there are many good ones out there, but we do offer references to what is available from our website. See sherline.com/cnc-links-and-resources/ for a wealth of information about CNC and G-code. CNC systems come with a CD that includes several free translation utilities to help convert your CAD files (in .DXF or .STL file formats) into G-code text.

Several Reasons to Consider CNC

There are several reasons people choose to use CNC over manual machining methods:

1. **CAPABILITY**—CNC makes it possible to turn all the handwheels at once so you can make curved, 3-dimensional shapes, helical gears or other designs that would be impossible to do manually. The ability to go directly from a CAD/CAM design to a CNC machined

- part has helped establish a new era of product design.
2. **PRODUCTION**—CNC can speed up the process on short run production parts. It can also take the boredom (and resulting mistakes) out of making the same part over and over again.
 3. **EDUCATION**—If you are thinking of becoming a machinist today, you will need to know how to use CNC. Learning on an inexpensive machine is an excellent training experience with no worries about “crashing” a more expensive, high powered machine.
 4. **CHALLENGE**—Some simply enjoy the challenge of seeing if they can get a high-tech robot to do what they command, and a computer controlled machine tool is simply a special purpose robot.

Longer Tables and Taller Milling Columns Available

Sherline now offers an 18" long mill table that adds 5" of extra X travel as well as a 15" tall mill column that adds 4" more Z travel. Matching inch or metric, and manual or CNC leadscrews

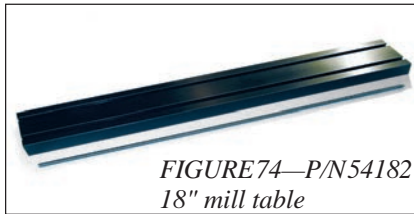

*FIGURE 74—P/N54182
18" mill table*

are available. These items can be ordered as a factory-installed option on new mills or can be retrofitted to any existing Sherline mill. Call for part numbers.

10,000 RPM Spindle Pulley Set (P/N 4335)

The standard pulley set allows a maximum spindle speed of about 2800 RPM, although the bearings are rated for 10,000 RPM. Sherline offers a special pulley set that gears the 6000 RPM motor up to 10,000 RPM at the spindle. A second pulley position offering a maximum 3000 RPM is similar to the high



speed ratio of the standard pulleys when you need more torque but less speed. This high spindle speed is useful for engraving operations or using very small drills or turning small shafts. Although torque is somewhat reduced, this is not normally a problem because you will be removing only small amounts of metal in those types of operations. We recommend reducing the preload adjustment on the spindle bearings from .0002" end play to .0003" to keep from overheating the bearings when using this accessory. Instructions to do this are provided.

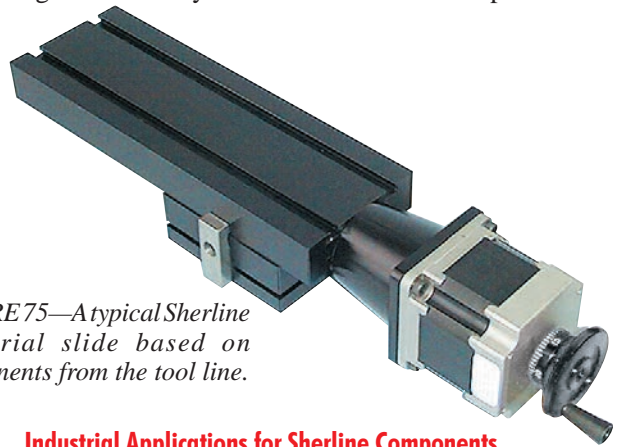

FIGURE 75—A typical Sherline industrial slide based on components from the tool line.

Industrial Applications for Sherline Components

For many years, Sherline spindles, slides and motor units have been especially popular with designers of custom tooling for small industrial applications because of the low cost and the large number of Sherline accessories that fit the spindle. In fact, we use them in our own production facility for a number of operations. Sherline is now offering a complete line of components made specifically for the production tooling designer. As you would expect, the size range is best suited for smaller operations, but if your needs fit within the specifications of Sherline components, excellent design results can be achieved. For more information on products from Sherline's Industrial Products Division, see our website at www.sherlineIPD.com.

DRO Machine Operations



FIGURE 76—A digital readout makes life easier for the machinist.

CAUTION!
Read all operating instructions carefully before attempting any machining operations.

The Digital Readout in the Modern Machine Shop

Digital readouts are popular on full size machine tools because they make the life of a machinist much simpler. They make it easier to accurately set or change the table position and eliminate errors caused by misreading handwheel increments or losing track of multiple rotations. Now that same convenience is available on tabletop size machines with the availability of a DRO (Digital ReadOut) for Sherline lathes and mills. The compact electronics package and clever backlash compensation feature were designed by John Wettroth.

On industrial DRO's, a sensor reads a highly accurate external scale. On Sherline's DRO, the sensor reads rotation of the leadscrew. Because of the accuracy of Sherline's precision rolled leadscrew threads and the short travels on a machine of this size, this system makes it possible to provide a DRO

with sufficient accuracy while maintaining a price appropriate for a machine of this size and cost.

The kit can be installed on any Sherline lathe or mill, regardless of age, and is very easy to use. Three axes of movement are provided so the readout can be used when the lathe is set up as a mill with the optional vertical milling column attachment. In the lathe configuration you will use only two of the three, as the tailstock spindle feed screw is not fitted with a readout. Remember that the directions of movement of the mill are referred to as the X-axis (table side-to-side), Y-axis (table in-out) and Z-axis (spindle up-down) when seen from the leadscrew handwheel end of the lathe. When used as a lathe, the nomenclature changes slightly. The crossslide feed handwheel still controls what is called the “X” axis, but the leadscrew controls what is now called the “Z” axis. Remember also that as you feed the cutter into the rotating part with the crossslide handwheel you will reduce the diameter of the part by twice the amount of the feed. This is because you are reducing the part’s radius but measuring its diameter. This DRO measures the change in *radius*.

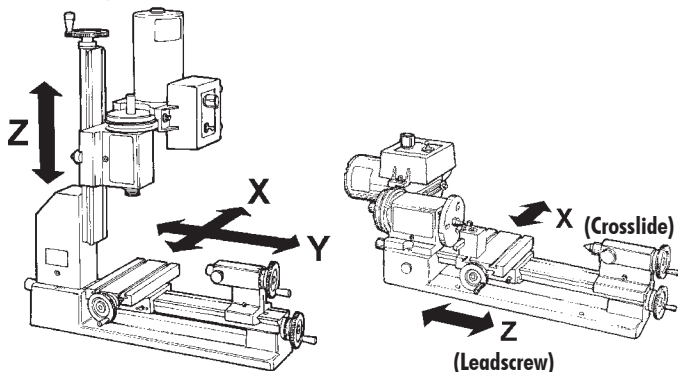

FIGURE 77—The designations of the axes of movement are different in lathe and mill configurations. A lathe used with a vertical milling column is considered a mill when it comes to naming the axes.

The readout of any axis can be set to zero at any time with the push of a button. As you move the handwheels you can read the table position to three and a half decimal places on the digital readout. It is not necessary to keep track of the number of handwheel rotations to figure the stopping point on larger dimensions. This will be especially appreciated when cranking in “negative” amounts. Backlash is compensated for by setting it into the unit’s electronic memory in increments of .0005". As a bonus, the package also includes an electronic readout of spindle RPM at all times.

Installing the DRO Components on Your Sherline Machine

The following instructions describe the steps required to remove the existing handwheels and thrust collars and replace them with the DRO encoder/handwheel units.

1. **LATHE:** Move the crossslide all the way in. This will help locate the slide screw to assure that the collar is centered. The saddle can be positioned anywhere on the leadscrew. **MILL:** Move the table all the way to the left. This will limit movement of the leadscrew and help center the new collar. Then move the table all the way to the front toward the operator.
2. Raise the headstock all the way up to the top of its travel on you mill. Do the same if you are using a vertical milling

FIGURE 78A—Installing the new thrust collar on the lathe crossslide screw, or on the mill X- and Y-axes.

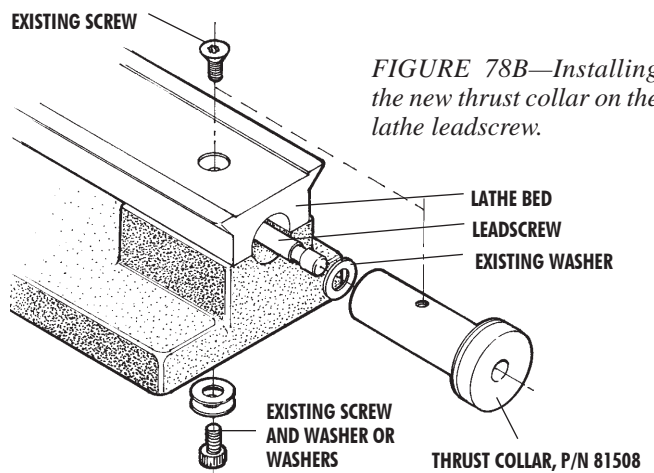
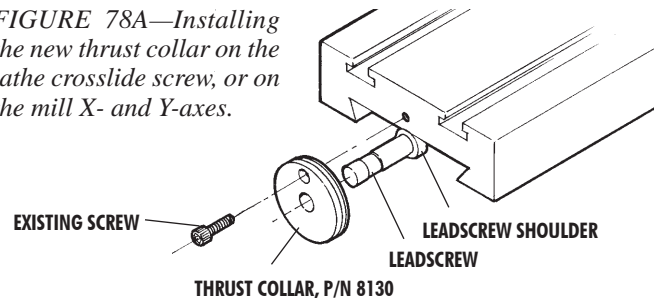

FIGURE 78B—Installing the new thrust collar on the lathe leadscrew.

column on a lathe.

3. Using a 3/32" hex wrench, remove all three handwheels by releasing their set screws and sliding them off their leadscrews. (If your machine has resettable “zero” handwheels, loosen the collar locking knob and rotate the collar until the hole lines up with the set screw. Then use the 3/32" hex wrench to loosen the set screw and remove the entire handwheel/collar unit.)
4. Using a 3/32" hex wrench, remove the 5-40 screw holding the thrust collar over the crossslide (lathe), or X- and Y-axes (mill) and remove the collar. (See Figure 78A.)

LATHE ONLY: Use a 1/8" hex wrench to remove the countersunk screw in the top of the lathe bed and a 5/32" hex wrench to remove the socket head cap screw under the lathe base so that the collar can be removed from the leadscrew. (See Figure 78B.)

5. Clean each grooved thrust collar with a solvent like acetone or lacquer thinner to remove any oil from the surface. (You will later lock them in place in relation to the plastic housing with “instant glue” and the glue will not stick to an oily collar.) Using the existing screws, install new grooved thrust collars on the X- and Y-axes, making sure the leadscrew is centered in the collar. Make sure the screws are secure, but do not overtighten. If a shim washer was present on your existing leadscrew, reinstall it as it was before.

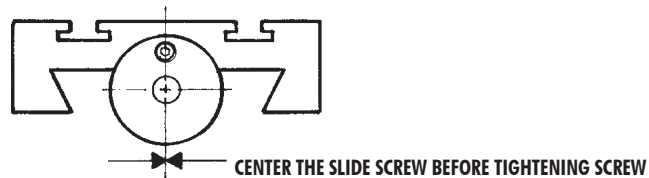

FIGURE 79—Making sure the crossslide screw is centered

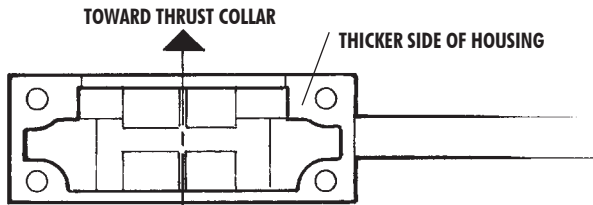

FIGURE 80—Detail of the encoder housing showing direction of installation

6. **LATHE:** Install a new handwheel with encoder ring on the crossslide screw and leadscrew. Note that the handwheels are similar except that on the leadscrew, the numbers face away from the handwheel. On the crossslide they face toward the handwheel. Make sure the shoulder at the end of the leadscrew thread is seated against the thrust collar and the handwheel is pushed in tightly to remove end play before tightening the set screw. On the crossslide, push the crossslide table toward the bed so that the collar is securely against the shoulder of the leadscrew. On the leadscrew, hold the table (not the base) with one hand and push the handwheel onto the shaft with the other. Rotate the handwheel so that the set screw tightens on

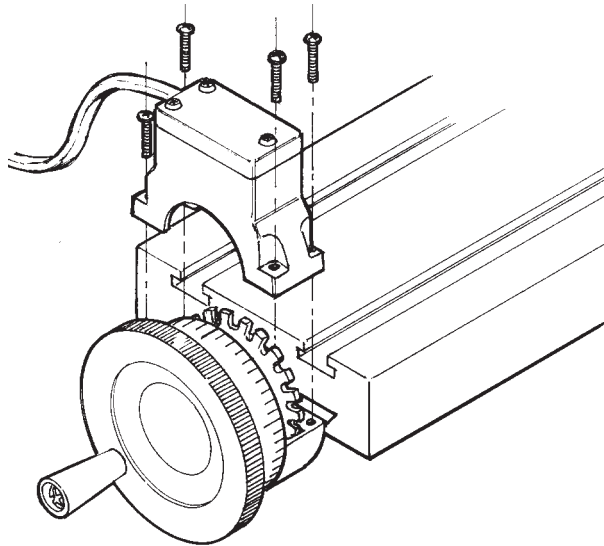

FIGURE 81—Installing the encoder unit over the thrust collar. The unit can be installed upside down to make it easier to put in the screws. It is then rotated into position and tightened to lock it in place.

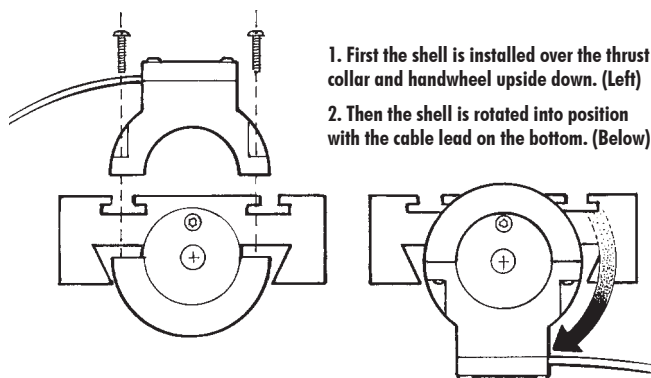

FIGURE 82—Rotating the unit into its proper position. (Note: Handwheel/encoder unit not shown for clarity.)

a new part of the shaft. If you don't, it will tend to pick up its old indentation making it difficult to tighten it in a new position.

MILL: Install a new handwheel and encoder ring on the X- and Y-axes. (The encoder ring has been factory installed on the handwheel for easier assembly.) Note that the X and Y handwheels are similar except that on the X-axis, the numbers on the handwheel face away from the handwheel. On the Y-axis they face toward the handwheel. Make sure the shoulder at the end of the leadscrew thread is seated against the thrust collar and the handwheel is pushed in tightly to remove end play before tightening the set screw. On the X-axis, push the table AWAY from the handwheel while pushing the handwheel onto the leadscrew shaft. On the Y-axis, hold the table (not the base) with one hand and push the handwheel onto the shaft with the other. Rotate the handwheel so that the set screw tightens on a new part of the shaft. If you don't, it will tend to pick up its old indentation making it difficult to tighten it in a new position.

See Figure 80 for orientation of the encoder housing. The thicker shoulder inside the encoder should be facing toward the thrust collar. It is easier to tighten the screws if you install the units upside down with the screws coming down from the top. Place the two halves of the shell over the thrust collar and over the encoder ring and install the four #2 x 3/8" self-tapping screws. Draw the screws down until they seat snugly, but DO NOT OVERTIGHTEN or you will strip the threads! Once tightened into position, the unit can be rotated around until the screws and cable are on the bottom. When finished, the cable from the encoders should come off to the right side of the handwheel.

7. **MILL and VERTICAL MILLING COLUMN:** Using a 1/8" hex wrench, remove the flat head screw that holds the Z-axis thrust collar to the vertical milling column. Remove the collar by lifting it up and off the leadscrew. If the spacer washer sticks to the bottom of it, remove it and reinstall it on the leadscrew shaft. Then remove

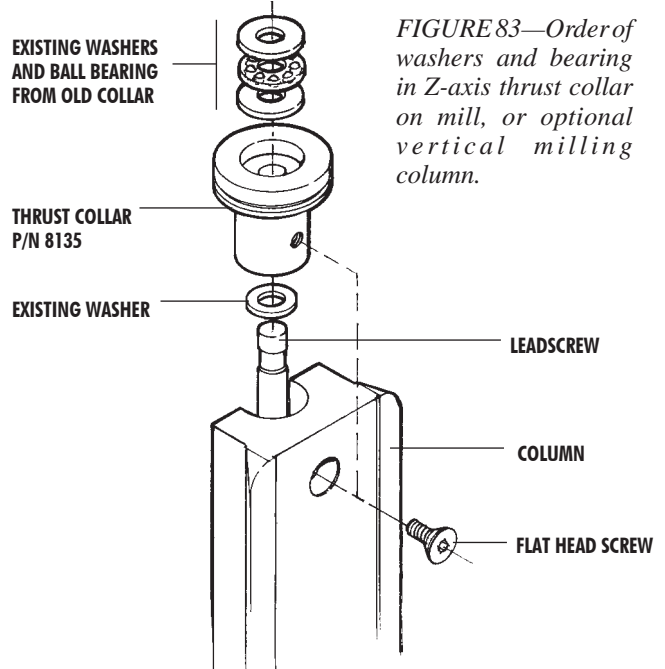

the ball bearing thrust and two washers from the collar and reinstall them in the new Z-axis thrust collar in the same order (See Figure 83). Install the new collar on the leadscrew shaft and secure it to the bed with the flat head screw.

8. Install the remaining handwheel and encoder unit onto the Z-axis leadscrew. Lift up on the saddle assembly until the washer and shoulder of the leadscrew are all the way up against the bottom of the collar. Then push down on the handwheel and tighten its set screw, being sure to tighten it against a new spot on the shaft. If installed on your machine, reinstall the 5-40 x 3/8" flat head screw through the center of the Z-axis handwheel and into the end of the leadscrew. See "Adjusting the Z-axis handwheel" on page 41 for more details on adjusting this screw. Install the pickup housing over the handwheel unit as shown in Figures 4 and 5. When finished, the cable should exit toward the left when viewed from the front.

Leadscrew Handwheel Position on the Model 4400 Lathe

The die cast base on the Model 4400/4410 long bed lathe is relieved so that the bed and base align. The lip on the bottom of the machined area will keep the sensor housing from being able to be rotated straight down. The solution to this is to orient the housing as shown in Figure 84 below. The joint between the two halves of the housing now becomes the witness mark against which you read the handwheel markings. On the Model 4400/4410 lathe, the bed and base are flush at the end, so the housing can be positioned straight down as is shown in the other figures.

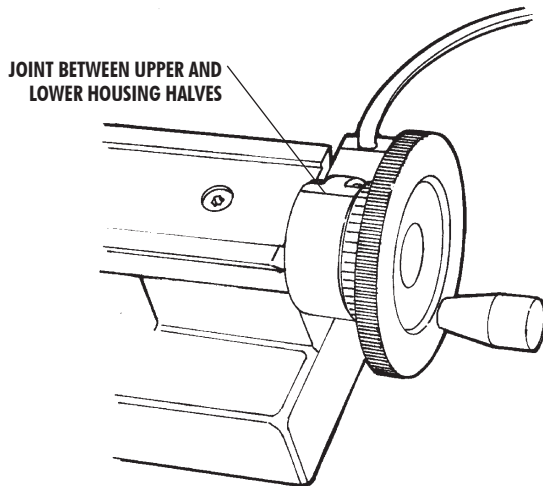

FIGURE 84—On the long bed lathe, the leadscrew handwheel sensor housing must be positioned as shown.

Making Sure the Housings Do not Move

The sensors that read gear-tooth position as you turn the handwheel are located in the bottom of the handwheel housing. If the housing moves, it is the same as if you moved the handwheel, because it changes the relationship between the sensor and the gear tooth. Therefore, the housing should be anchored in place so that it cannot be inadvertently moved. The screws that hold the two halves together go into plastic, and overtightening them can strip the threads out of the hole. If the housing rotates too easily when the screws are tightened, you can remove the housing shell and sand the mating surfaces on a piece of sandpaper on a flat surface until they grip the

collar more tightly. If this doesn't do the job, another solution is to place a drop of "super glue" between the plastic housing and the metal collar once the housing is positioned where you want it. This will keep it in place but can still be broken loose if you need to later.

Installing the RPM Sensor

1. Reinstall the headstock/motor/speed control onto the lathe or milling column.
2. Peel off the backing and apply the 2-1/2" round sticker to the pulley. (HINT: A little liquid window cleaner on the pulley allows the sticker to be repositioned and bubbles squeezed out before it adheres. Once the liquid is squeezed out and dries, the adhesive on the sticker will stick fine.)
3. **Locate the RPM sensor by holding it in the position shown in Figure 7.** Mark the center of the hole on the plastic belt housing and drill a 1/16" hole. Fasten the sensor to the belt housing using the self-tapping screw provided. (Do not overtighten or you can strip the threads.) A plastic tie-wrap is provided to secure the sensor lead to the motor's power cord to keep it out of the way.

NOTE: If you have a machine with an older AC/DC motor that does not have a plastic belt guard, the RPM sensor can be mounted in the proper position over the pulley by attaching it to the motor mounting bracket. Locate and mark where the hole should be drilled. Remove the motor and drill a hole through the bracket. You can use a self-tapping sheet metal screw or a bolt and nut through the hole, or you can tap the hole to match the thread of the bolt you use.

Hooking up the Connecting Cables

Plug the cable connector from each encoder unit into its respective port on the display unit. The telephone type cable connectors go in with the locking tab facing up when the unit is lying on its back. The RPM sensor cable goes into the port marked "Tach In."

Plug the power adapter into the bottom hole marked "DC In," and plug the transformer into a 115 VAC (60 Hz.) source. Check to make sure all three axes are functioning. Turn on the motor and check to see that the RPM indicator is functioning.

Initializing Your Display for Inch or Metric Leadscrews

When you press the "Power" button to turn your system on, the upper right corner of the display will read either "inch" or "metric" mode. Normally, the DRO will be set up properly when you receive it, but there is always a possibility it could be set wrong. To set or change the system of measurement your unit displays, follow these steps:

1. With the power off, unplug the power cable from the display unit.
2. **INCH**—Hold down both the "Power" button and the X-axis button while you plug the power cord back into the display unit. After the display comes up, release the buttons. The display should now read in inch dimensions.
3. **METRIC**—To initialize your display unit to read metric dimensions, hold down the "Power" and "Y" buttons while plugging the power cord back into the display unit. Once initialized, the unit will always read in your chosen system of measurement each time it is turned on unless you change it.

**NOTICE! THE DISPLAY DOES NOT
CONVERT DIMENSIONS FROM INCH TO METRIC!**

The DRO reads rotary handwheel movement and converts it to a linear dimension based on a formula assuming a certain leadscrew thread pitch. The DRO must be set to agree with the leadscrews installed on your machine to provide accurate measurements.

The only difference between the inch and metric packages is the number of divisions engraved into the handwheels. The electronics package is the same for either and can be set to read in either measurement system depending on the leadscrews of the machine on which it is installed.

Setting the Backlash Compensation Values

To set backlash compensation for each axis, you must first measure to determine what the backlash is. Use a dial indicator to determine how far the handwheel on each axis rotates before the table starts to move. (If this amount is excessive, see your instruction manual for instructions on setting backlash. It should ideally be in the .003" to .005" range.) Once the amount is determined, the backlash is compensated for by setting it into the display unit's memory.

To set the backlash to correspond to your machine's leadscrews, complete the following steps for each axis:

1. Turn the handwheel for each axis one full turn clockwise. This assures that the software starts the backlash compensation at the proper initial point.
2. Hold down the "Power" button for longer than a second until the display changes.
3. Now you can set in the backlash for each axis by pushing the button for that axis. Each time the button is depressed, .0005" (or .01 mm on metric units) is added to the reading. Set in the amount of backlash you measured previously for each axis. Amounts up to .015" (.50 mm) can be set. (Note: You cannot cycle backwards to a lower number. If you go past your desired setting you must continue pushing the button until the reading passes .015" (.50 mm) and returns to zero. Then start over.)
4. Once the backlash for all three axes is set, briefly push the "Power" button again to return the display to its normal reading. The backlash setting can be checked or changed at any time by holding the power button until the display changes. The amount can then be reset as described in instruction number 3 above. Once set, backlash settings are held in a special memory chip even if the unit is turned off and unplugged. They remain until you change them.

**Using the DRO with the Sherline Power Feed
or Thread Cutting Attachment**

The DRO leadscrew thrust collar is longer than the standard thrust collar so that the DRO housing can attach to it. This changes the position of the leadscrew. This has no effect on the lathe except when it is used with a power feed or thread cutting attachment. In those cases you will need to replace the existing sliding engagement shaft (P/N 1509) which will be a little too short. If you return the existing shaft to Sherline it will be replaced at no charge with a shaft of the appropriate length (P/N 81509) for use with the DRO. If you purchase a

new power feed or thread cutting attachment, notify Sherline that you will be using it with the lathe DRO and the proper shaft will be supplied with your purchase. The only alternative to solving this problem would have been to provide a longer leadscrew which would have been far more expensive.

Adjusting the Z-Axis Handwheel Screw

To adjust tension on the screw, first remove all Z-axis backlash in the conventional manner by lifting the motor/speed control unit by hand while tightening the handwheel set screw on a "fresh" quadrant of the leadscrew to avoid picking up any previous indentations. Once adjusted, tighten the new center screw only until it is "finger tight". Use a very small amount of Loctite® on the end of the screw to keep it in place. (Do not coat the threads or the screw may become impossible to remove.) Overtightening the screw will cause the handwheel to become hard to turn. The purpose of the screw is not to adjust backlash, but rather to keep it from increasing once it is properly adjusted. Do not try to use the screw to pull out additional backlash. The small 5-40 threads are not strong enough for this task.

Reversing the Direction of the Reading on the X-axis

The X-axis readout is designed to read negative numbers when the handwheel is turned in the clockwise direction and positive when turned counter-clockwise. Should you wish to change your readout so that it uses a standard x-y plot, you can do so by switching two of the four wires coming from the encoder for the X-axis.

To do so, unplug the X-axis cable from the readout box. Remove the four screws that secure the lower housing to the upper housing and then remove the encoder halves from the handwheel. On the bottom of the half with the encoder is a cover plate secured by three screws. Remove these screws and the cover plate. This will expose the soldered connections for the four wires coming from the encoder. To reverse the direction of the readout, unsolder the green and black wires. Reverse their position and re-solder to the encoder leads. Reinstall in reverse order. The diagram below shows the factory locations of the wires before the swap is made.

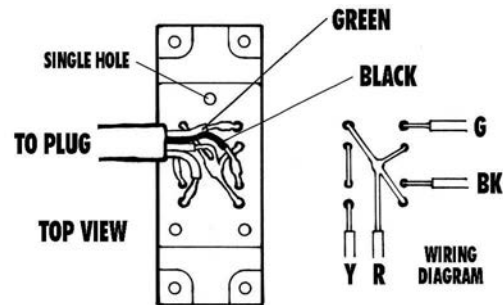

Figure 85—The drawing on the left shows the encoder housing and wires coming from the plug. The diagram to the right shows a schematic of where each wire is connected. Swapping the black and green wires will change the + (plus) and - (minus) directions of the readout.

NOTE: The wires and solder joints are small and delicate. If you don't have a suitable soldering iron and a little expertise along these lines you may return your encoder housing to the factory and we will make the change for you at no charge. Call first for a return authorization number and instructions on how to return your housing.

A Few More Tips

When in use, shield the unit from chips so they don't accumulate around the telephone jack connections on the side. Do not use an air hose to clean the unit.

A metal stand is now included with your DRO so you can stand the unit up on your workbench. This makes it easier to read while you work. If you wish to secure the box to the stand, a piece of double-sided foam tape is a good method.

Getting the Most out of Your DRO

When using a machine equipped with a digital readout, we find it is best to use either the readout or the handwheels, but not both. If the displayed accuracy of .0005" (.01mm) is satisfactory for the job you are doing, use just the digital readout and disregard the handwheel settings. In cases where you might want to interpolate to a higher degree of accuracy, the markings on the handwheels will allow you to do this.

An example of this would be where you have located the

center of a bored hole and then changed the table position. To return the spindle exactly to the hole's center again using the digital readout could leave you a few ten-thousandths off, which may not be acceptable. In this case, you should write down your handwheel settings and direction the handwheel was last turned before moving from the desired location. This will allow you to return to the same spot with great accuracy. The handwheel marks are .001" or .01mm apart. By reading the space between the marks on the handwheel and interpolating your position, you can achieve a high degree of accuracy. Knowing your machine is an important part of achieving this kind of accuracy, and as you get more familiar with your machine, your accuracy will continue to improve.

Sherline's DRO brings modern machine shop technology down to tabletop size and makes your Sherline tools easier and more fun to use. We think you will find the digital readout to be a great addition to your Sherline machine shop.

Installing Stepper Motors

CAUTION!

Read all operating instructions carefully before attempting any machining operations.

Stepper Motor Installation Instructions

In order to prevent damage during shipment, some of the stepper motors have not been installed. Install them using the following procedure:

1. If not already installed, carefully plug the white cable connector into the slot in the motor. Orient the motor so the plug is either on the right side or on the bottom to keep chips and coolant from causing a possible electrical short at the connection. If you wish, a small amount of silicon sealant or hot melt glue can be used to secure the white plug to the motor and seal the joint.
2. Note the location of the flats on the stepper motor shaft. Always assure that the coupler and handwheel set screws

are tightened against the flat on the shaft. Tightening the set screw against the round part of the shaft can gall the shaft and make it impossible to remove from the coupler later.

3. Align the coupler set screw with the access hole in the side of the stepper motor mount and assure that the set screw is sufficiently released so that the motor shaft can be inserted.

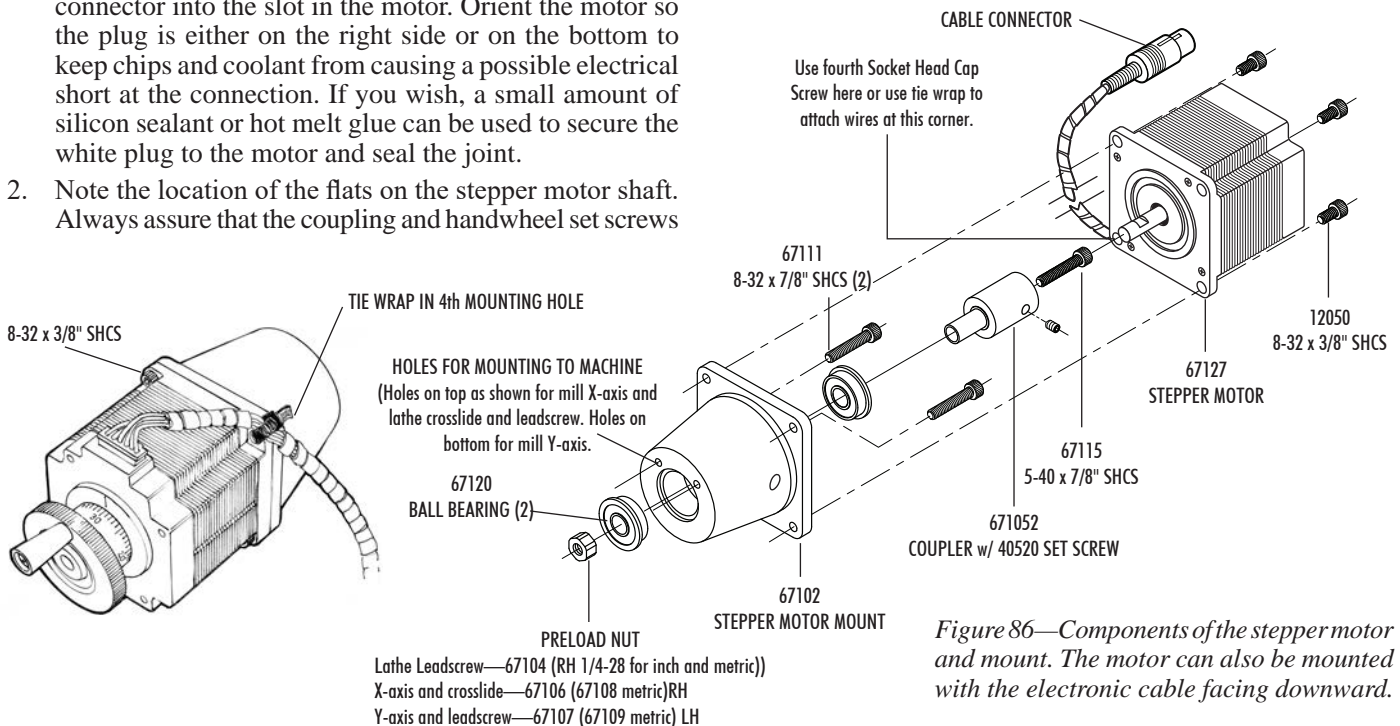

Figure 86—Components of the stepper motor and mount. The motor can also be mounted with the electronic cable facing downward.

- Insert the motor shaft into the coupling, making sure the set screw is aligned with the flat. Keep the motor square to the mount so as not to flex the coupling during insertion. Loosely tighten the set screw.
- Install three 8-32 x 3/8" socket head cap screws (SHCS) through the holes in the motor flange and into the stepper motor mount holes. Instead of a 4th screw in the four o'clock position use a tie wrap through that hole to secure the wire bundle from the motor. This will help relieve strain on the motor plug connection.
- Assure that the flat on the motor shaft is still aligned with the coupling set screw (observe the position of the rear flat or handwheel set screw—the two flats are parallel) and tighten the coupling set screw. Install and turn the handwheel and observe the movement of the leadscrew to make sure everything is turning smoothly.

Using Handwheels on the Stepper Motors

When turning an unpowered stepper motor by hand you may notice a slightly “notchy” feel because of the permanent magnets in the motor. This is normal. When the motors are powered up they lock in position, and it will be very difficult to move them with the handwheels. Therefore, if you wish to use manual mode, you should first turn off the power to the motors using the ON/OFF switch on the external driver box or on the side of the computer if the driver box is built in. Turning a DC motor by hand causes it to act as a generator, sending current backward through the circuit. However, low amounts of current will not damage the board, so avoid cranking faster than about 1 rev/sec to be safe. For longer travels, use EMC’s jog mode for approximate positioning, then turn off driver box power and use the handwheel for fine tuning.

Sherline Stepper Motor Specifications—Nmb Motors

Sherline P/N:	67127 (w/ DIN plug and flats of shaft) 67130 (no plug, flats on shaft)
Manufacturer:	NMB (Minebea Co. Ltd.)
Mfg. P/N (Type):	23KM-K035-62V (double shaft)
Frame size:	NEMA #23
Step angle:	1.8°
Voltage:	3.2 V
Current:	2.0 A/Φ
Resistance:	1.6 Ω/Φ
Inductance:	3.6 mH/Φ
Holding torque:	9.7 kg-cm
Rotor inertia:	250 g-cm ²
Number of wire leads:	6 (See color code diagram FIG. 2)
Weight:	1.32 lb (0.6 Kg.)
Length:	2.13" (54 mm)
Shaft:	Double ended, 1/4" diameter

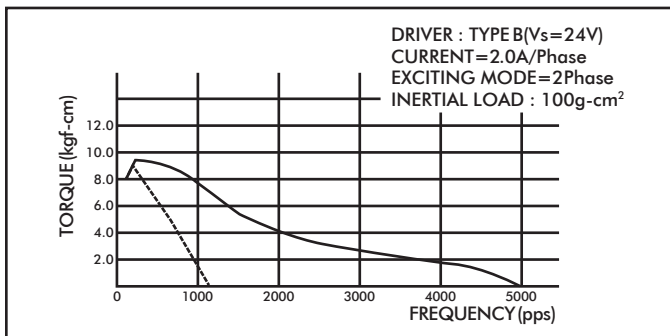

Figure 87—Motor torque curve

Lead Wire Connection and Color Code

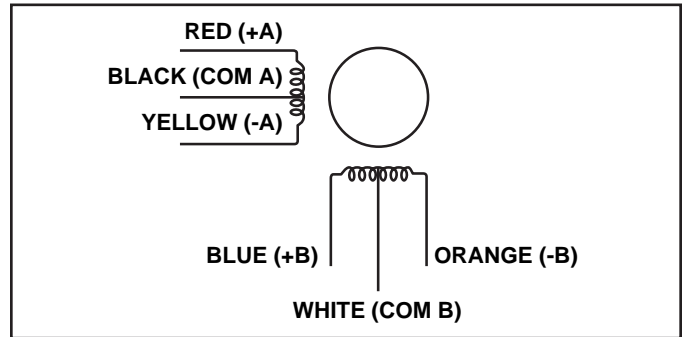

FIGURE 88— Color of internal wiring for NMB motors

See Figure 89 for the pin diagram and wire color layout of the stepper motor connector cables we supply with our stepper motors. Since there is no industry standard for wire colors in this field, if using a connector not supplied by Sherline each pin and color should be confirmed with a continuity tester before applying power.

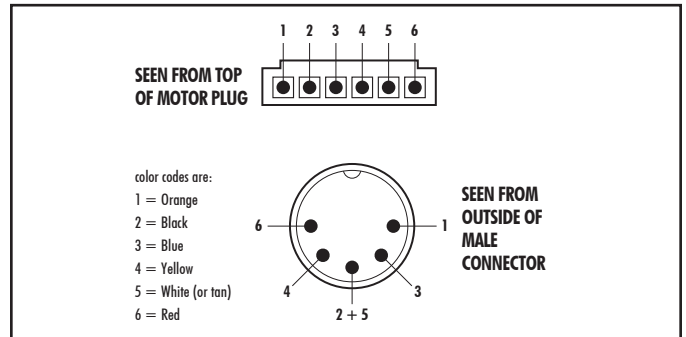

FIGURE 89: diagram shows which pin in the DIN connector is wired to which position in the motor connector.

NOTE: Motors can be wired in either unipolar or bipolar configuration depending on how the leads are connected. Sherline motors with plugs are wired for unipolar operation.

PRECAUTIONS

- Make sure the ends of raw wires are not touching each other when turning the handwheel by hand to drive the stepper motor and leadscrew. It can cause the motor to feel rough and hard to turn.
- DC motors generate current when hand cranked that can damage the control unit. When positioning a stepper motor by hand using the handwheel, do not crank faster than about 1 rev/second. For long travels, use the jog mode of your CNC control software.
- Poor connections can cause arcing, which can burn out motors or control chips. Always make sure plugs and connections are fully engaged and making good contact.
- Always turn off driver box power before plugging in or unplugging a stepper motor.

“A man who works with his hands is a laborer.
A man who works with his hands and his brain is a craftsman.
A man who works with his hands, his brain and his heart is an artist.”

—Louis Nizer

Sherline CNC Motor-Mounting Instructions

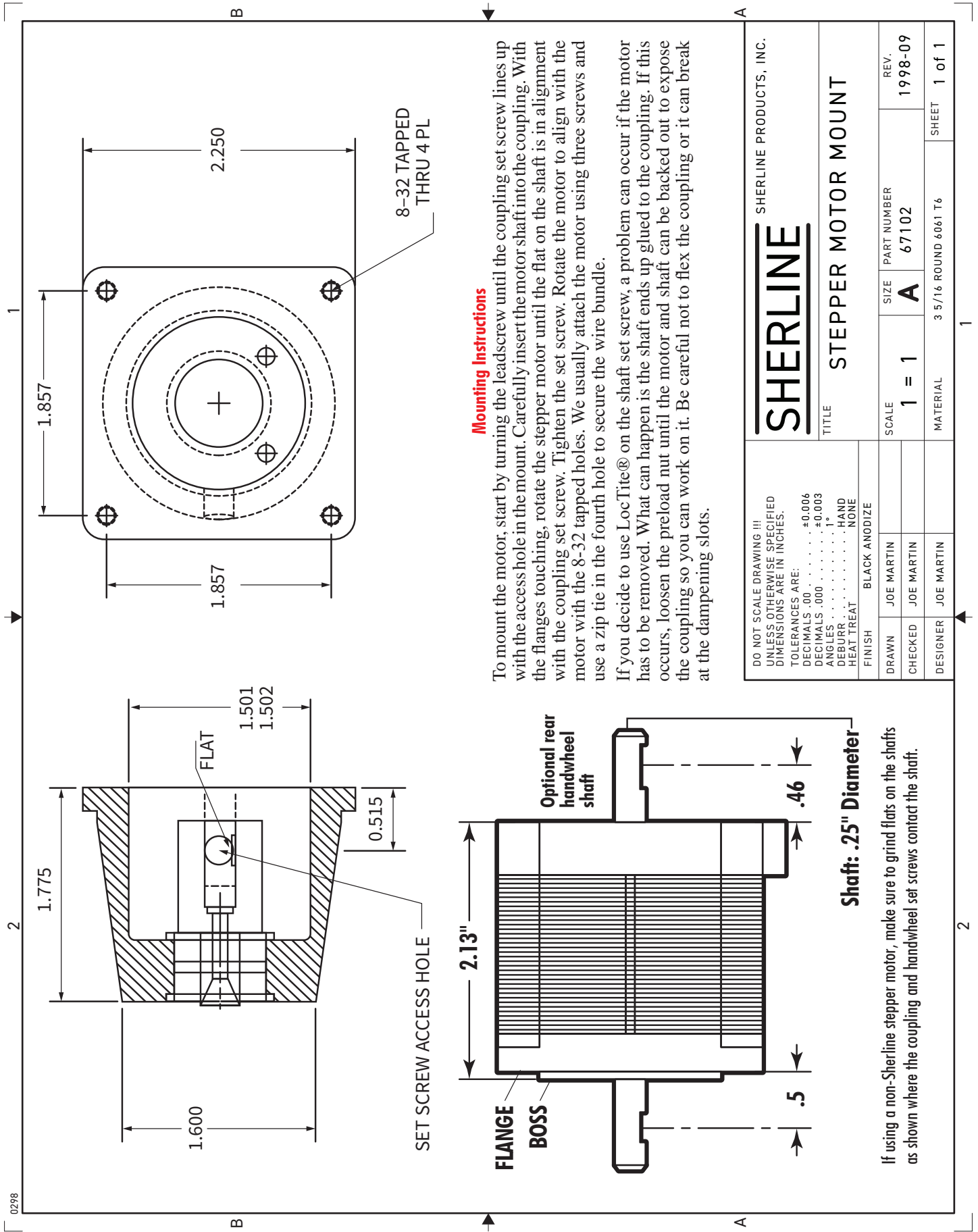

Mounting Instructions

To mount the motor, start by turning the leadscrew until the coupling set screw lines up with the access hole in the mount. Carefully insert the motor shaft into the coupling. With the flanges touching, rotate the stepper motor until the flat on the shaft is in alignment with the coupling set screw. Tighten the set screw. Rotate the motor to align with the motor with the 8-32 tapped holes. We usually attach the motor using three screws and use a zip tie in the fourth hole to secure the wire bundle.

If you decide to use LocTite® on the shaft set screw, a problem can occur if the motor has to be removed. What can happen is the shaft ends up glued to the coupling. If this occurs, loosen the preload nut until the motor and shaft can be backed out to expose the coupling so you can work on it. Be careful not to flex the coupling or it can break at the dampening slots.

DO NOT SCALE DRAWING !!! UNLESS OTHERWISE SPECIFIED DIMENSIONS ARE IN INCHES. TOLERANCES ARE: DECIMALS .00 ±0.006 DECIMALS .000 ±0.003 ANGLES 1° DEBURR NONE HEAT TREAT NONE		SHERLINE PRODUCTS, INC. <h2 style="margin: 0;">SHERLINE</h2>	
FINISH BLACK ANODIZE		TITLE STEPPER MOTOR MOUNT	
DRAWN	JOE MARTIN	SCALE	1 = 1
CHECKED	JOE MARTIN	SIZE	A
DESIGNER	JOE MARTIN	PART NUMBER	67102
		MATERIAL	3 5/16 ROUND 6061 T6
		REV.	1998-09
		SHEET	1 of 1

If using a non-Sherline stepper motor, make sure to grind flats on the shafts as shown where the coupling and handwheel set screws contact the shaft.

FIGURE 90

Replacement parts can be ordered through your dealer or directly from Sherline. If in doubt about whether you are ordering the correct part number, please contact Sherline.

We will be glad to help you make sure you are selecting the proper parts for your needs. For a complete list of parts and prices see sherline.com/sherline-price-lists/.

Sherline Manual Lathes Exploded View and Part Numbers

NOTE: Where different, Inch part number is given first, followed by Metric part number.

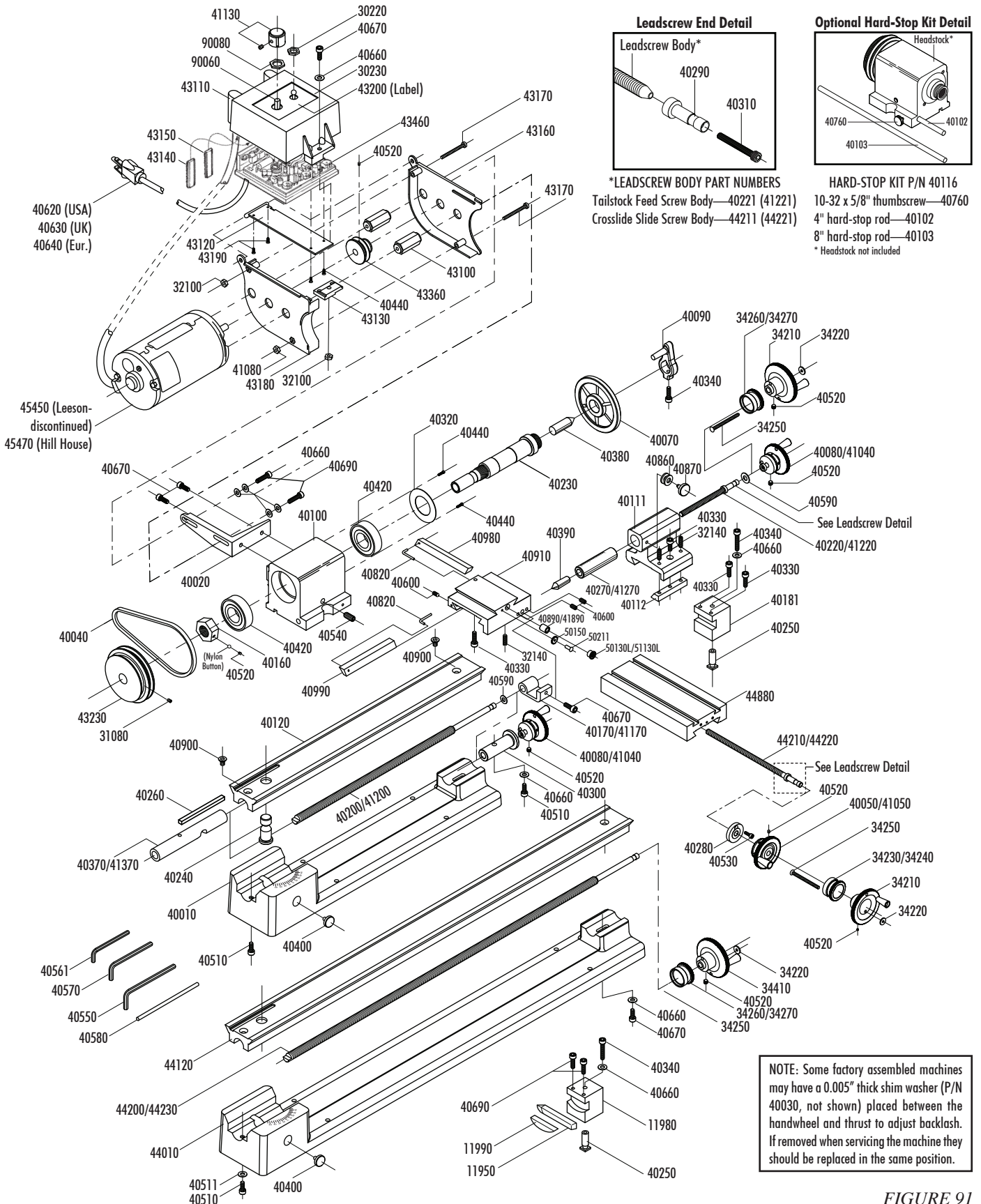

FIGURE 91

Sherline CNC-Ready Lathe Exploded View and Part Numbers

NOTE: Where different, Inch part first, followed by Metric part number.

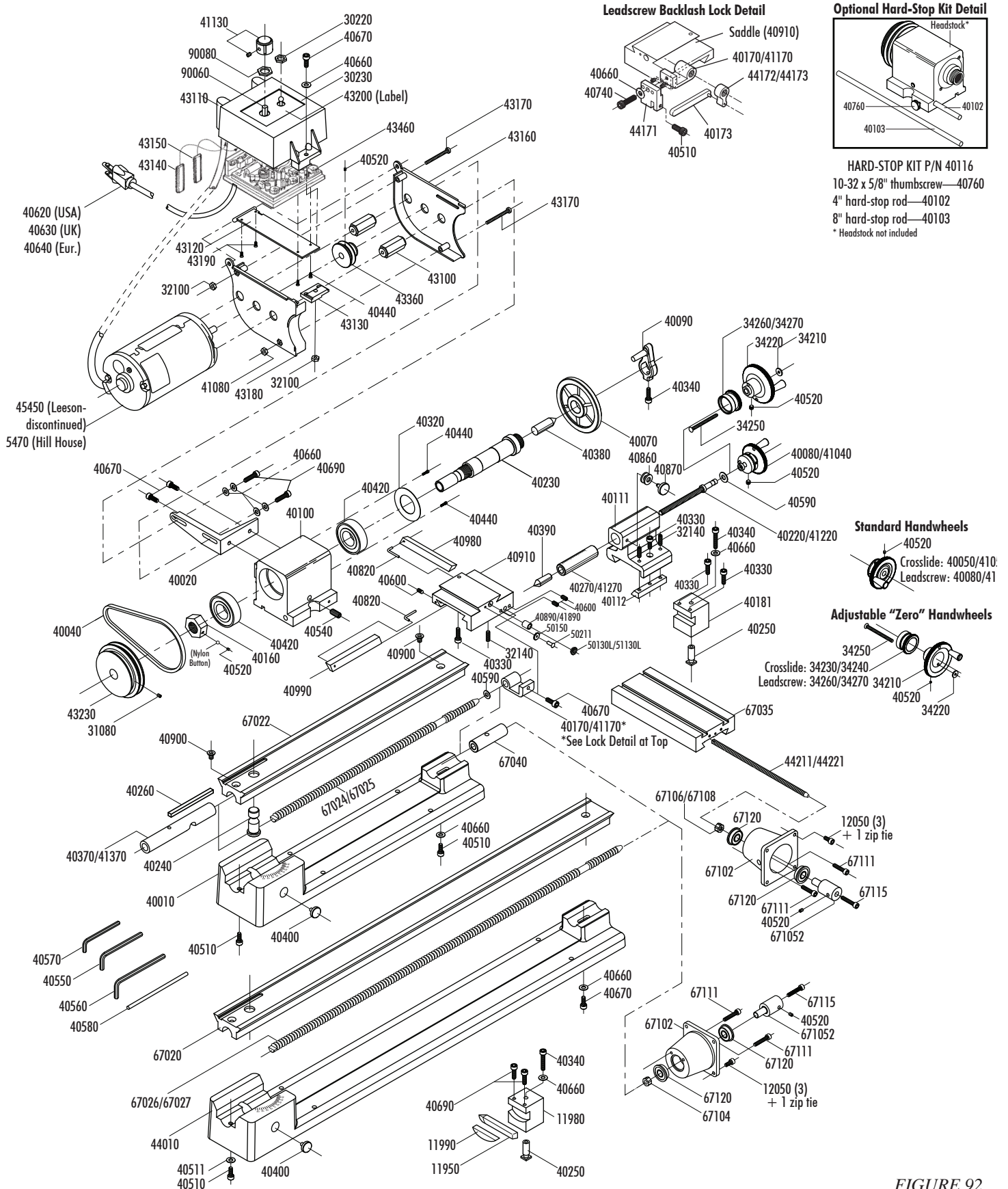
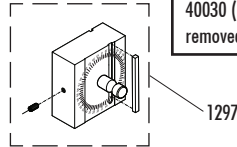
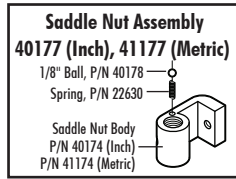
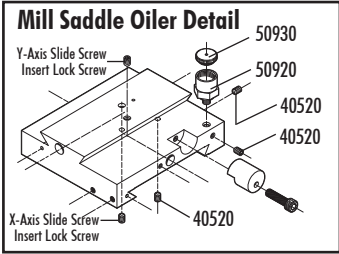

FIGURE 92

Sherline Manual 5000- and 5400-Series Vertical Milling Machines

NOTE: Where different, Inch part number is given first, followed by Metric part number.



NOTE: Some factory assembled machines may have a 0.005" shim washer P/N 40030 (not shown) placed between the handwheel and thrust to adjust backlash. If removed when servicing the machine they should be replaced in the same position.

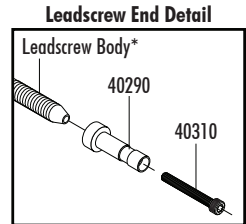
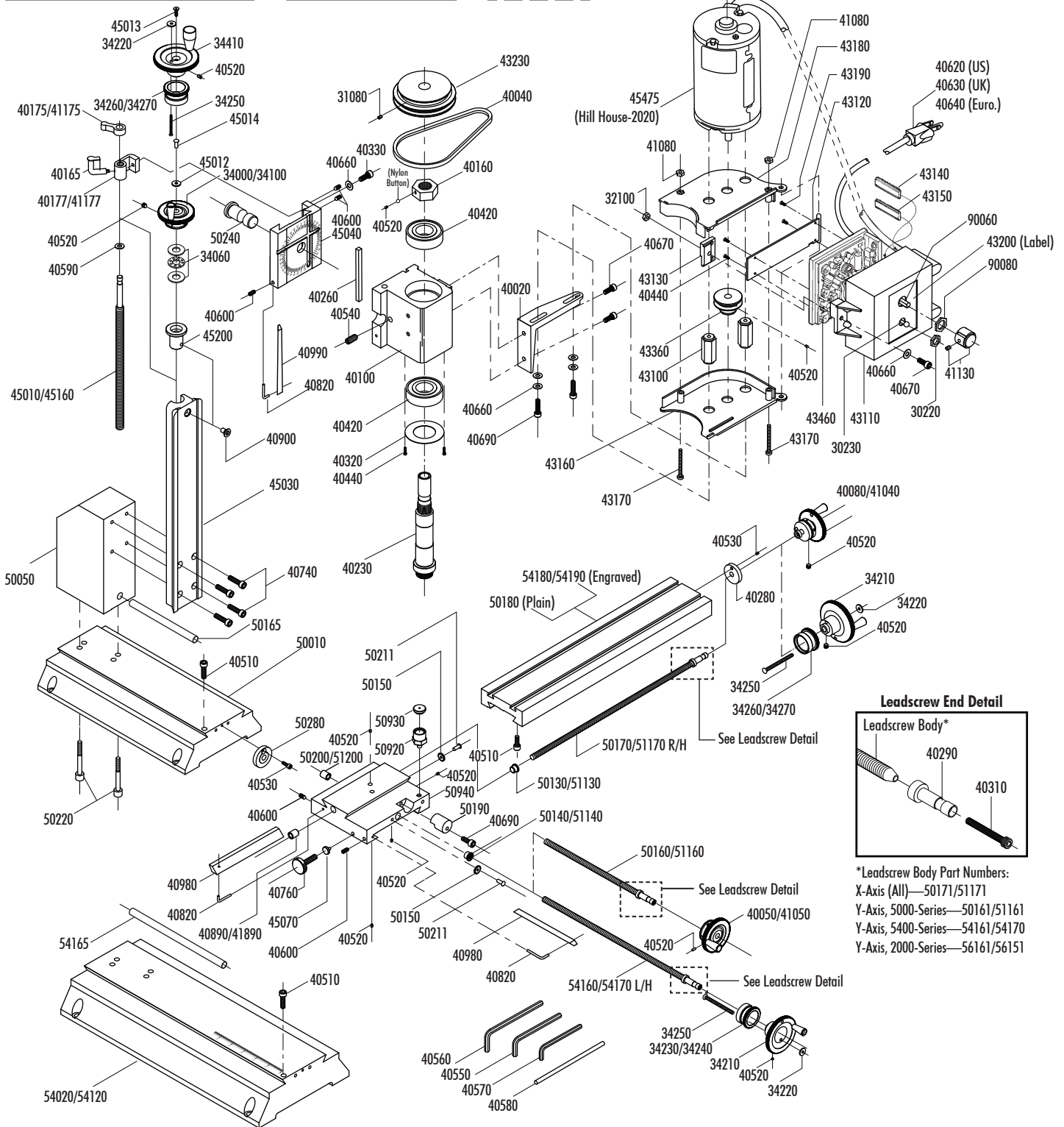

*Leadscrew Body Part Numbers:
X-Axis (All)—50171/51171
Y-Axis, 5000-Series—50161/51161
Y-Axis, 5400-Series—54161/54170
Y-Axis, 2000-Series—56161/56151

FIGURE 93

Sherline CNC-Ready 5000- and 5400 Series Vertical Milling Machines

NOTE: Where different, Inch part number is given first, followed by Metric part number.

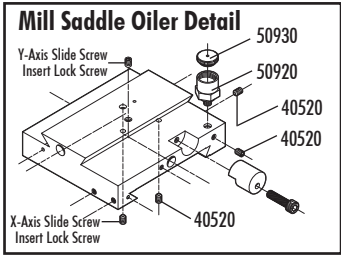

Exploded View and Part Numbers

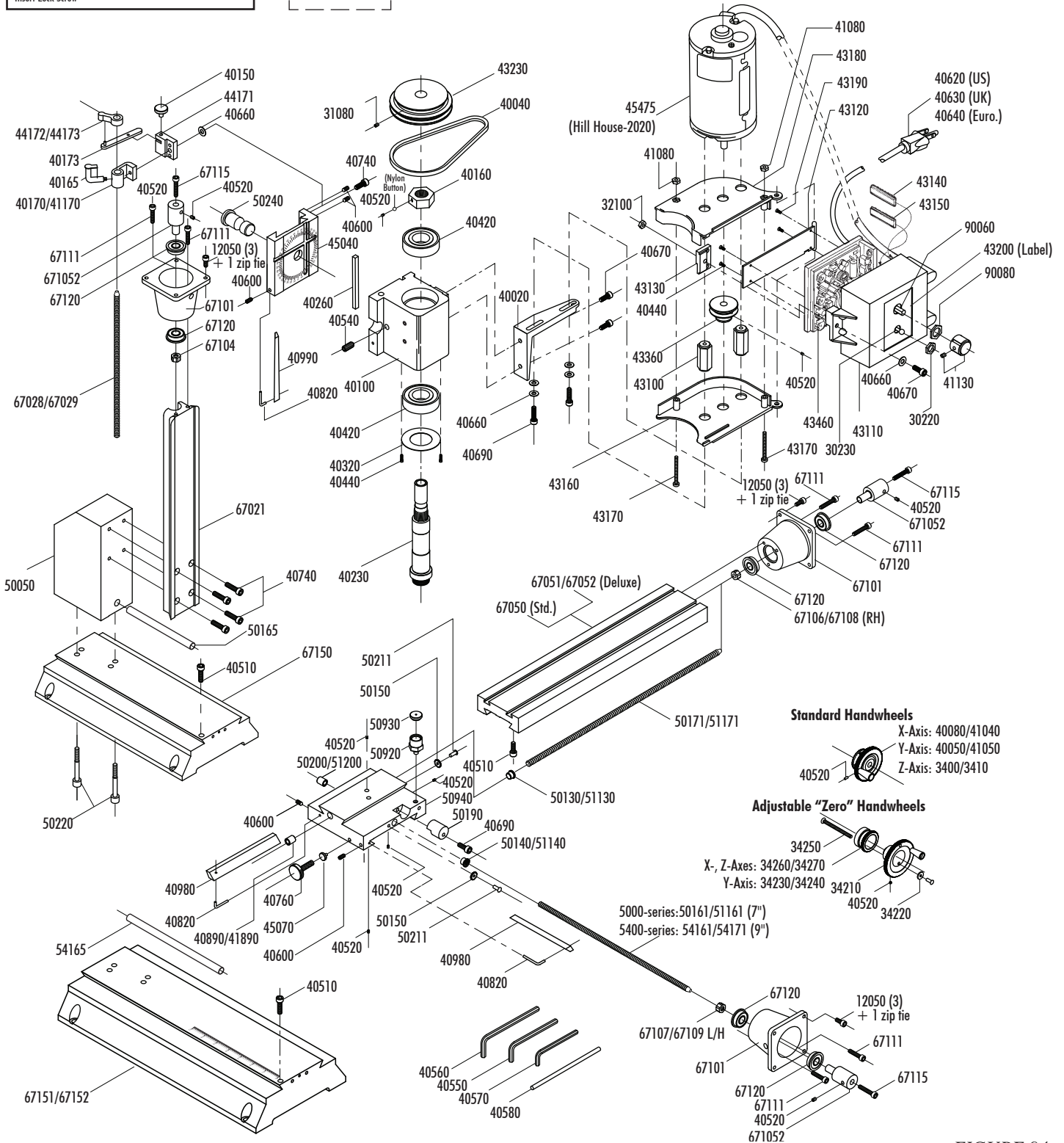
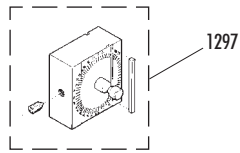

FIGURE 94

Sherline Manual Model 2000/2010 Vertical Milling Machine

NOTE: Where different, Inch part number is given first, followed by Metric part number.

Exploded View and Part Numbers

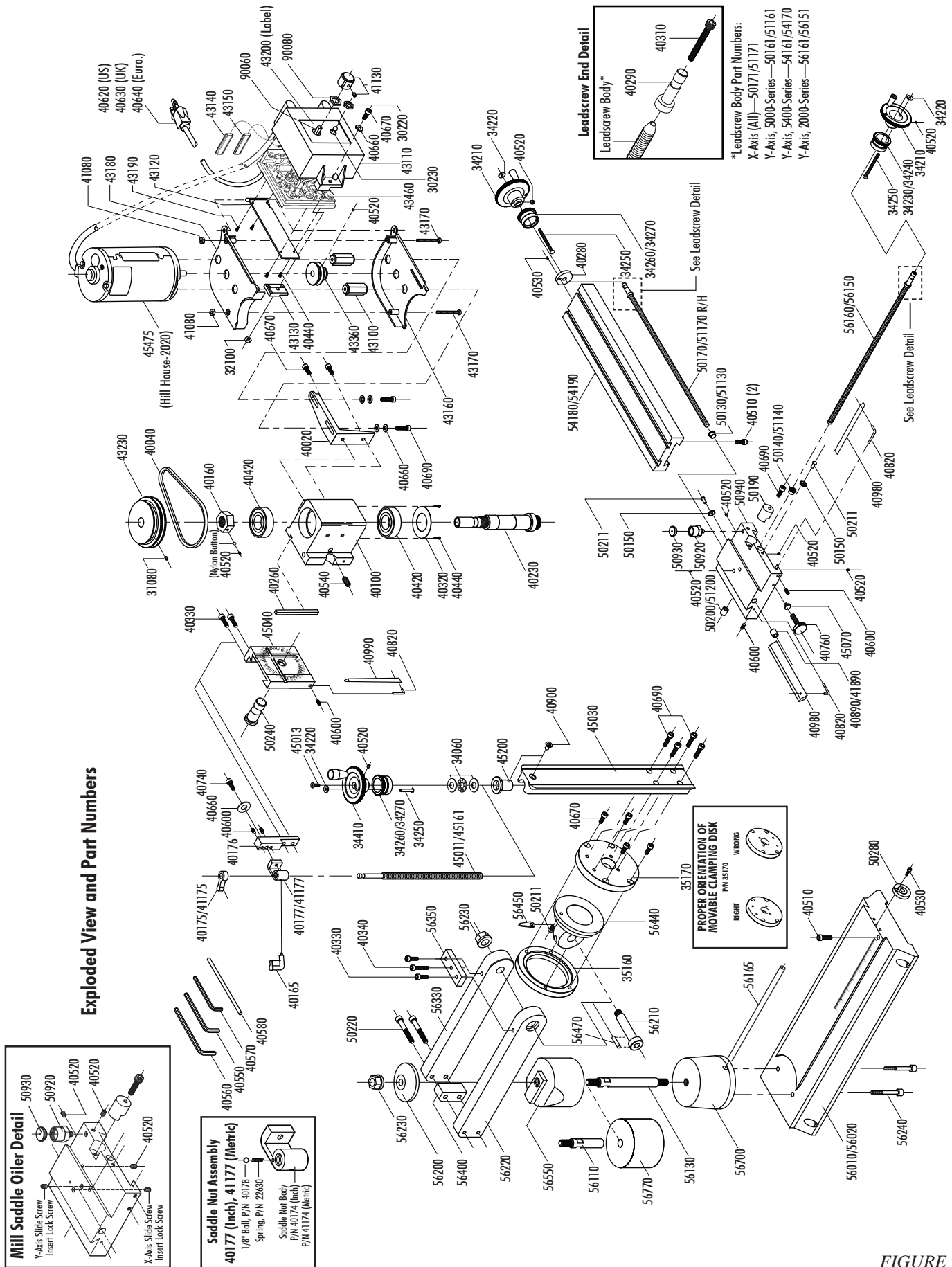

FIGURE 95

Sherline CNC-Ready Model 2000/2010 Vertical Milling Machine

NOTE: Where different, Inch part number is given first, followed by Metric part number.

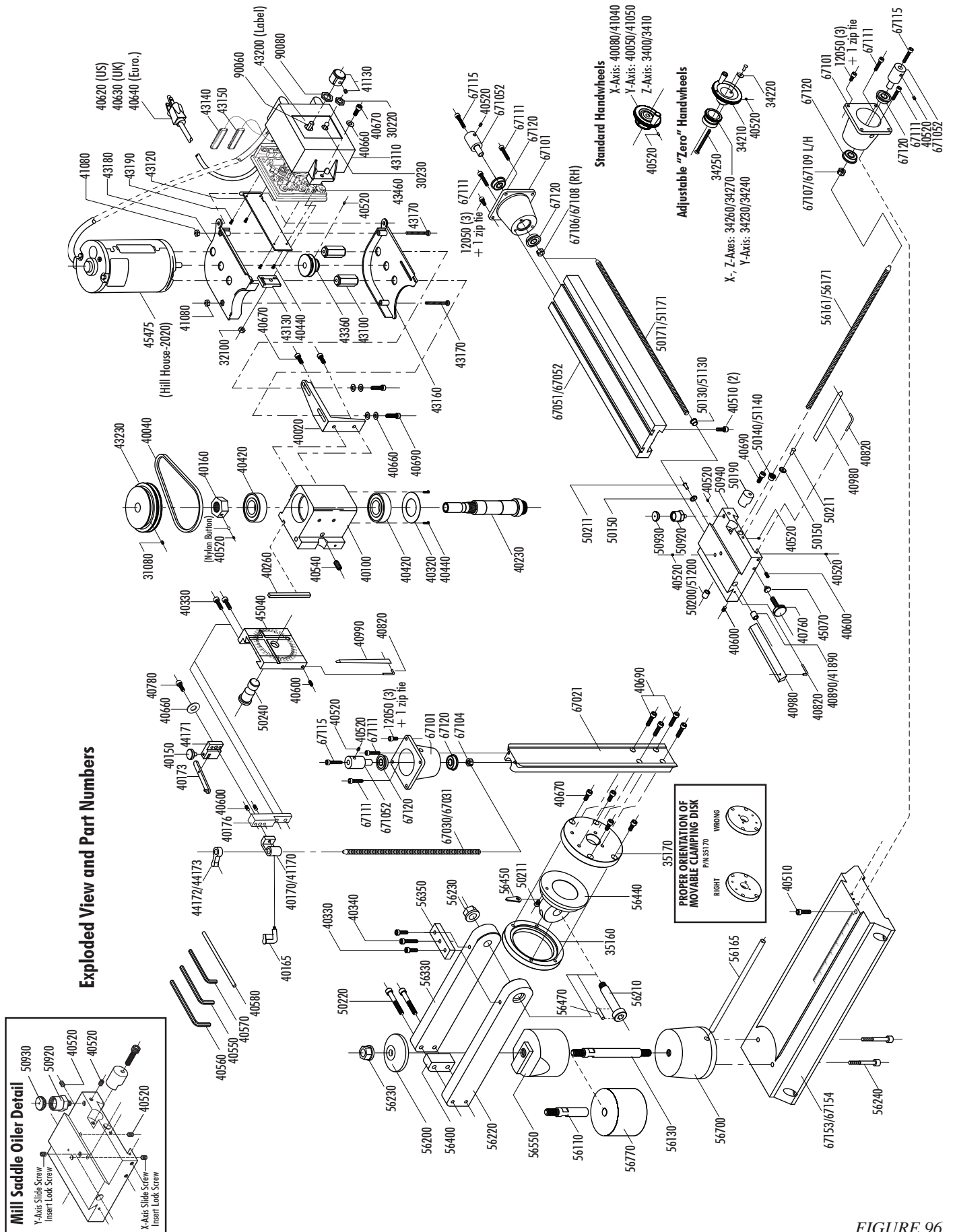

FIGURE 96

Sherline Manual Model 5800/5810 Vertical Milling Machine

NOTE: Where different, Inch part number is given first, followed by Metric part number.

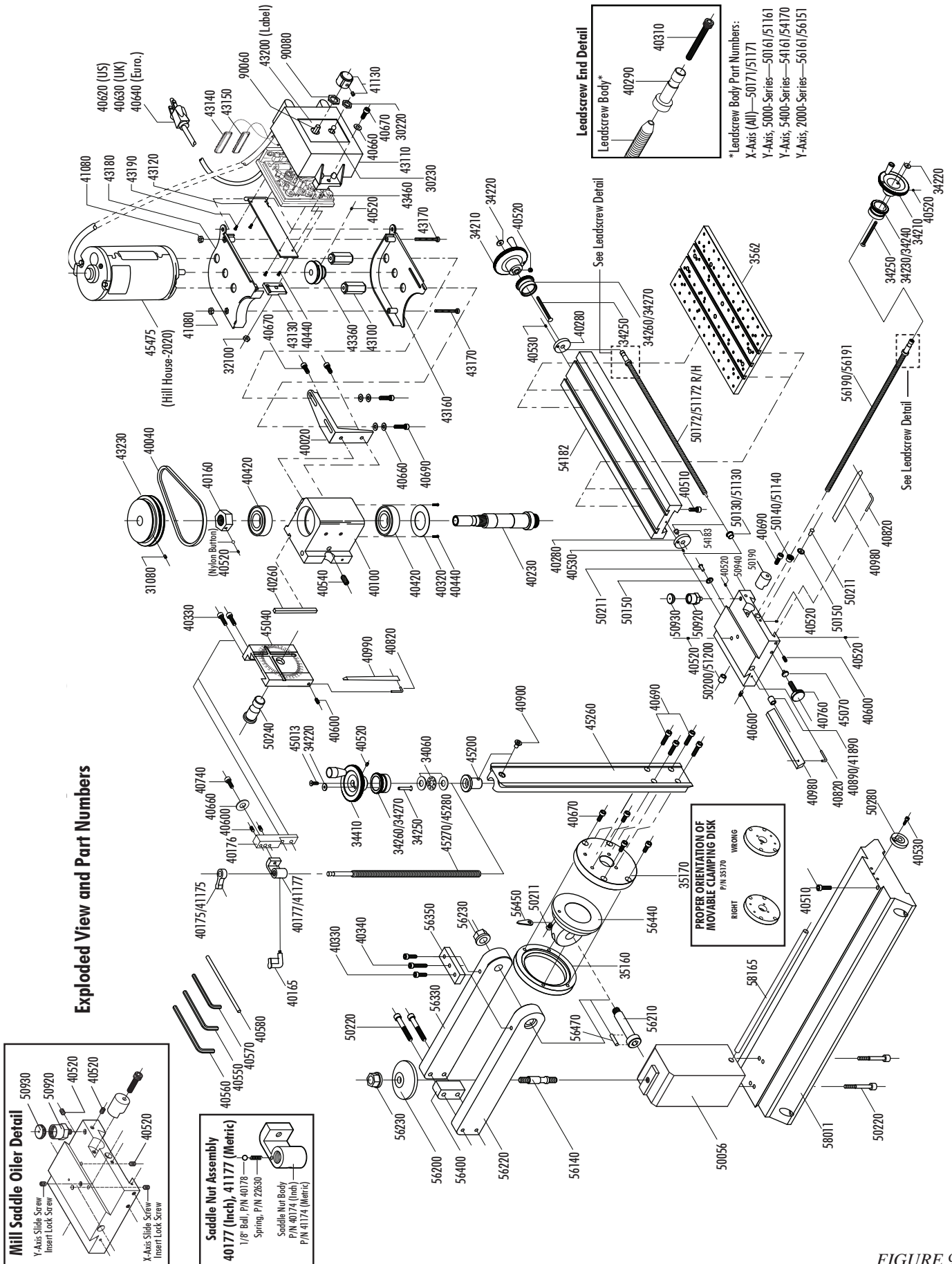

FIGURE 97

Sherline CNC-Ready Model 5800/5810 Vertical Milling Machine

NOTE: Where different, Inch part number is given first, followed by Metric part number.

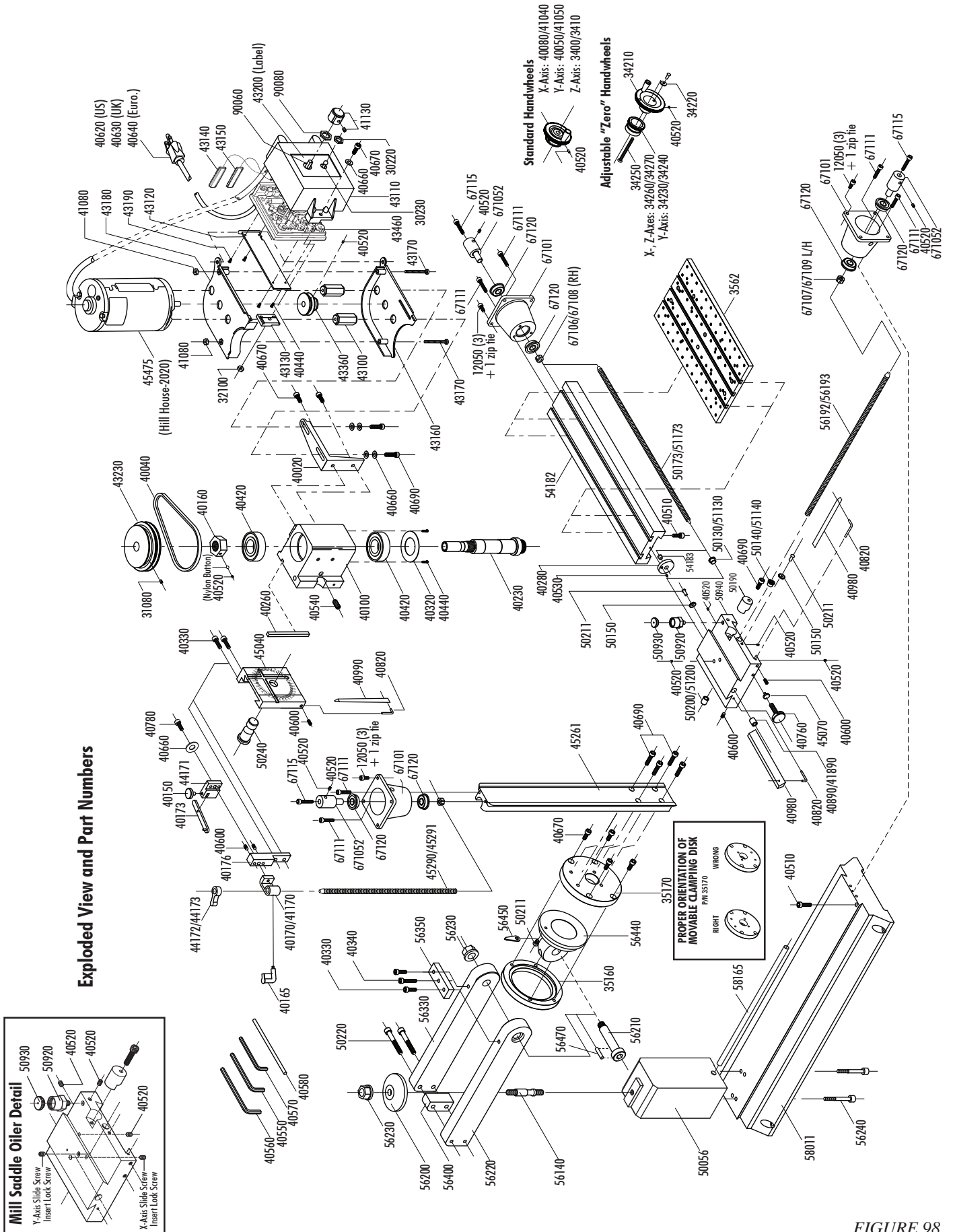

FIGURE 98

Machining Basics—Using the Handwheels

Precision leadscrews and the handwheels that drive them make it possible to produce highly accurate parts on a mill or lathe. Here are some tips that should help first-time machinists get off to a good start.

Handwheel Increments

The handwheels on Sherline machines are marked in increments of one one-thousandth of an inch (.001") for inch models or one one-hundredth of a millimeter (.01 mm) for metric models. One turn of the handwheel causes the leadscrew to advance the tool or part .050" (inch models) and 1 mm (metric models). The leadscrews are precision rolled and are quite accurate. Therefore, moving the handwheel three rotations, for example, moves that axis exactly .150" (or .03 mm on metric machines). This precise method of moving the tool or part is what makes it possible to make accurate parts on a metalworking lathe or mill.

When advancing the crossslide handwheel to take a cut on the lathe, keep in mind that the amount of metal removed is actually twice the amount you dial in. You are removing a given amount of material from the *radius* of the part, which means you are actually removing twice that amount from the *diameter* of the part. (Some lathes are set up with the crossslide feed reading the amount the diameter is reduced, however, since it is possible for Sherline lathes to also be used in a milling configuration where the crossslide feed becomes the X-axis feed for milling, this system was not used.)

Turning the Handwheels

Each handwheel has a small handle. This is mainly used to advance the leadscrew quickly over long distances. When actually making a cut, or at least when making the final cut on a part, most machinists will turn the handwheel itself, using the outer surface and alternating back and forth between hands to keep a smooth,

continuous feed going. On small machines, the handwheel is turned by its outer knurled surface using the thumb and a finger of one hand. Then, as that hand is released, the thumb and finger of the other hand pick up the rotation. Using the handle on the handwheel can introduce pushing and pulling motions that can adversely affect the finish. (See Figure 86.)

FIGURE 86—A two-handed technique for turning the handwheels yields a better final finish on your part. Shown in use here is an adjustable “zero” handwheel.



Adjustable “Zero” Handwheels

Adjustable handwheels are optional on all Sherline machines and are standard on the deluxe models. The increments are marked on a collar which can be disengaged from the handwheel and reset to “zero” or any other desired setting. To release the collar, turn the black, knurled release knob on the outer face of the handwheel counter-clockwise. The collar can then be adjusted without moving the handwheel itself. When reset to zero, carefully retighten the black locking knob to reengage the collar and then advance the handwheel. The advantage of this system is that it can eliminate errors when “dialing in” a dimension, as you are starting from zero each time, rather than adding one number to another to come up with the next stopping point.

Sherline Machine Technical Specifications

LATHES	4000 (4100)	4400 (4410)	VERTICAL MILLS	5000 (5100)	5400 (5410)	2000 (2010)	5800 (5810)
Swing over bed	3.50" (90 mm)	3.50" (90 mm)	Max. clearance, table to spindle	8.00" (203 mm)	8.00" (203 mm)	9.00" (229 mm)	14.00" (356 mm)
Swing over carriage	1.75" (45 mm)	1.75" (45 mm)	Throat (no spacer)	2.25" (50 mm)	2.25" (50 mm)	(Adjustable)	(Adjustable)
Distance between centers	8.00" (200 mm)	17.00" (430 mm)	(w/ headstock spacer)	(optional)	3.50" (90mm)	(Adjustable)	(Adjustable)
Hole through spindle	.405" (10 mm)	.405" (10 mm)	Travel, X-axis*	8.65" (220 mm)	8.65" (220 mm)	8.65" (220 mm)	13.65" (347 mm)
Spindle nose ext. thread	3/4-16 T.P.I.	3/4-16 T.P.I.	Travel, Y-axis	3.00" (76 mm)	5.00" (127 mm)	7.00" (178 mm)	11.00" (279 mm)
Spindle nose int. taper	#1 Morse	#1 Morse	Travel, Z-axis*	6.25" (159 mm)	6.25" (159 mm)	5.38" (137 mm)	9.38" (238 mm)
Spindle runout of Morse taper	.0005" or less	.0005" or less	Hole through spindle	.405" (10 mm)	.405" (10 mm)	.405" (10 mm)	.405" (10 mm)
Travel of crossslide	3.25" (83 mm)	3.25" (83 mm)	Spindle nose ext. thread	3/4-16 T.P.I.	3/4-16 T.P.I.	3/4-16 T.P.I.	3/4-16 T.P.I.
Tailstock spindle taper	#0 Morse	#0 Morse	Spindle nose int. taper	#1 Morse	#1 Morse	#1 Morse	#1 Morse
Protractor graduations	0° to 45° by 5°	0° to 45° by 5°	Spindle runout of Morse taper	.0005" or less	.0005" or less	.0005" or less	.0005" or less
Handwheel graduations	.001" (.01 mm)	.001" (.01 mm)	Handwheel graduations	.001" (.01 mm)	.001" (.01 mm)	.001" (.01 mm)	.001" (.01 mm)
Leadscrew Pitch	.050"/rev (1 mm/rev)	.050"/rev (1 mm/rev)	Leadscrew Pitch	.050"/rev (1 mm/rev)	.050"/rev (1 mm/rev)	.050"/rev (1 mm/rev)	.050"/rev (1 mm/rev)
Electronically controlled spindle speed range	70 to 2800 RPM	70 to 2800 RPM	Electronically controlled spindle speed range	70 to 2800 RPM	70 to 2800 RPM	70 to 2800 RPM	70 to 2800 RPM
Length overall**	23" (584 mm)	32.5" (826 mm)	Width overall**	14.75" (375 mm)	15.00" (381 mm)	15.00" (381 mm)	20.00" (508 mm)
Width overall**	10.25" (260 mm)	10.55" (267 mm)	Depth overall**	11.75" (298 mm)	14.00" (356 mm)	22.25" (565 mm)	23.13" (588 mm)
Height overall**	8" (203 mm)	8.5" (216 mm)	Height overall (Max.)**	20.75" (527 mm)	20.75" (527 mm)	23.38" (568 mm)	24.50" (622 mm)
Shipping weight	24 lb. (10.9 kg)	30 lb. (13.6 kg)	Table size	2.75" x 13.00" (70 mm x 330 mm)	2.75" x 13.00" (70 mm x 330 mm)	2.75" x 13.00" (70 mm x 330 mm)	2.75" x 18.00" (70 x 457 mm)
			Hold-down provision	2 T-slots	2 T-slots	2 T-slots	3 T-slots
			Shipping weight	33 lb (15.0 kg)	36 lb (16.3 kg)	38 lb (17.2 kg)	50 lb. (22.7 kg)
			Movements in addition to X-, Y- and Z-axes	Headstock rotation (90° L/R)	Headstock rotation (90° L/R)	Headstock rotation (90° L/R)	Headstock rotation (90° L/R)
						Column rotation (90° L/R)	Column rotation (none)
						Column pivot (90° Fwd/Bk)	Column pivot (90° Fwd/Bk)
						Column swing (90° L/R)	Column swing (90° L/R)
						Col. travel (In/Out) 5.5" (140 mm)	Col. travel (In/Out) 5.5" (140 mm)

Spindle Motor Specifications
 Input voltage—100 to 240 VAC, 50 to 60 Hz
 Output to motor—90 VDC
 Current draw—5 to 15 amps depending on load
 No-load output shaft speed—6000 RPM (no pulley)

NOTE: Motor and speed control can be purchased separately. Part numbers are as follows:

P/N 33050—DC Motor and Speed Control

P/N 33060—Headstock, DC Motor, Speed Control

* Standard dimensions listed. Optional longer tables and taller columns with extra travel are available.

** All overall dimensions include motor and speed control.

Sherline's founder, Joe Martin, put together the ultimate book for the Sherline machinist...

This Book Gives You Not Just the "Hows," But Also the "Whys" of Machining

The Perfect "Next Step" Beyond this Instruction Book

Right now you are holding one of the most complete instruction manuals ever given away with any machine tool, regardless of size or price. However, as complete as it is, most new machinists will have more questions than can be answered in a basic instruction guide. The book, *Tabletop Machining*, gave Sherline's founder, Joe Martin, the chance to stretch out and expand these basic instructions to include much more detail on the machines and processes related to working with metal. Naturally, the book can not provide step-by-step instructions for your particular project, but rather it concentrates on the basics of metalworking. Armed with the right facts, tips and techniques, the machinist can then apply what is learned to his particular needs. Information is given on selecting materials; using a lathe and a mill; using measurement tools; coolants; sharpening cutting tools; using accessories for threading, indexing and gear cutting; setting up a home shop and much more. Plans and instructions for several projects of varying levels of difficulty are provided for beginning machinist so you can get started.

Creative Inspiration as Well as Instruction

A gallery of photos of superb miniature projects will show

you what others have been able to produce using miniature machine tools. Seeing these fine projects will set your mind to work in all sorts of new directions. A history of Sherline tools is also included. It is written from the point of view of giving you some guidance if you've ever thought of starting your own business or taking a product of your own to market.

Printing Quality You'd Expect in a Book that Chronicles the Quest for Perfection

This book will be equally at home on your living room coffee table or your shop workbench. Printed on 350 pages of high quality, glossy paper, this large 8.5" x 11" softbound book is packed with over 400 detail-rich color photos and hundreds of informative line drawings by former Sherline art director and technical illustrator, Craig Libuse. The "lay-flat" binding makes it easy to read and use as a reference in your shop. The 12-point cover is laminated with a plastic coating to protect it. Both the quality of the printing and the information

within have resulted in excellent reviews from customers and magazine editors alike. If you like tools and working on small, intricate projects, you should plan on adding this book to your library.

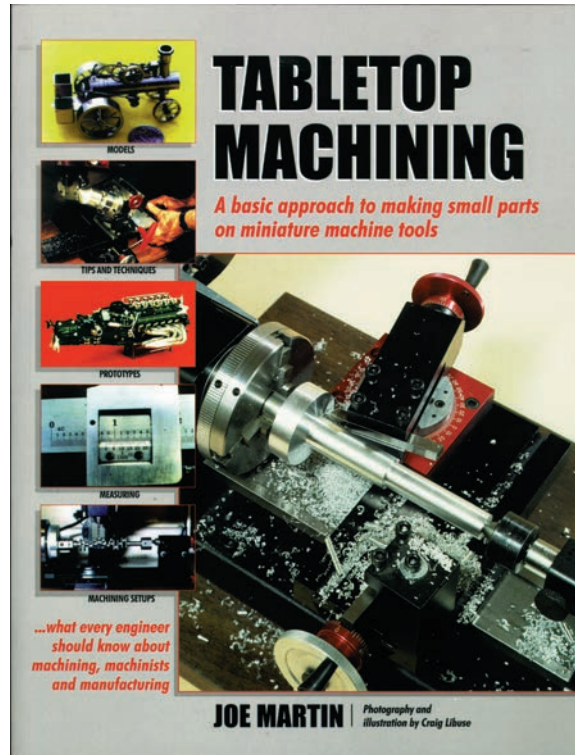

P/N 5301 (Softbound)—\$42.00



Sherline's factory and offices
in Vista, California, USA

SHERLINE PRODUCTS

INCORPORATED 1974

3235 Executive Ridge, Vista, CA 92081-8527, USA
Toll Free Orders (USA): 1-800-541-0735 • Local/International/Technical Assistance: 1-760-727-5857
Fax: 1-760-727-7857 • Email: sherline@sherline.com

www.Sherline.com

Products Made in USA • Manual Printed In USA

Enjoy the work of some of the world's
best craftsmen at

www.CraftsmanshipMuseum.com



1/8 scale running John Deere tractor model by
Jerry Kieffer, DeForest, WI.