

MR60FDA1

60GHz mmWave Sensor

– Fall Detection Module Pro User Manual



Table of Contents

1. Overview	4
2. Electrical characteristics and parameters	5
2.1 Detection angle and distance	5
2.2. Electrical characteristics	5
2. 3. RF performance	5
3. Module dimensions and pin description	6
3.1 Module size package	6
3. 2. Pin description	6
3.2 Using the wiring diagram	7
4. Main working properties	7
4.1 Radar module operating range	7
4.2. Main functions and performance	8
5. How the radar works and how it is installed	9
5.1. Vertical mounting mode	9
5.2. Tilt mounting mode	10
5.3. Horizontal mounting mode	10
6. Typical applications	10

1. Overview

Radar module MR60FDA1 utilizes 60G millimeter wave technology to detect human motion and posture, enabling the fall monitoring function. This module utilizes an FMCW radar system to enable wireless detection of personnel status at a particular location.

Radar modules have the following characteristics:

1. Realize the function of personnel position detection and report the statistics;
2. Restrict the detection object to objects with biological characteristics (moving or stationary) and eliminate interference from other inanimate objects in the environment;
3. This module is capable of eliminating the effects of nonliving objects and can also detect moving nonliving objects;
4. It supports secondary development and can adapt to a variety of applications;
5. A universal UART communication interface protocol;
6. Four groups of input and output are reserved for user-defined input and output or simple interface simulation;
7. The power output is not significant enough to cause harm to the human body.

2. Electrical characteristics and parameters

2.1 Detection angle and distance

Content	Minimum	Typical	Maximum	Units
MR60FDA1				
Radius of movement of people detection [1]	–	6		metre
Fall monitoring radius [2]	–	2.5		metre
Radar detection angle (horizontal)	–	100	–	degree
Radar detection angle (pitch)	–	100	–	degree

Note: [1][2] Radar hang height 2.8 m, radius of radar projection.

2.2. Electrical characteristics

Content	Minimum	Typical	Maximum	Units
Operating voltage (VCC)	4.5	5.0	6	V
Operating current (ICC)	90	93	100	mA
Operating temperature (TOP)	-20	-	+60	°C
Storage temperature (TST)	-40	-	+80	°C

2.3. RF performance

Parameters				
Operating frequency (fTX)	58	-	63.5	GHz
Transmitted power (Pout)	-	-	6	dBm

3. Module dimensions and pin description

3.1 Module size package

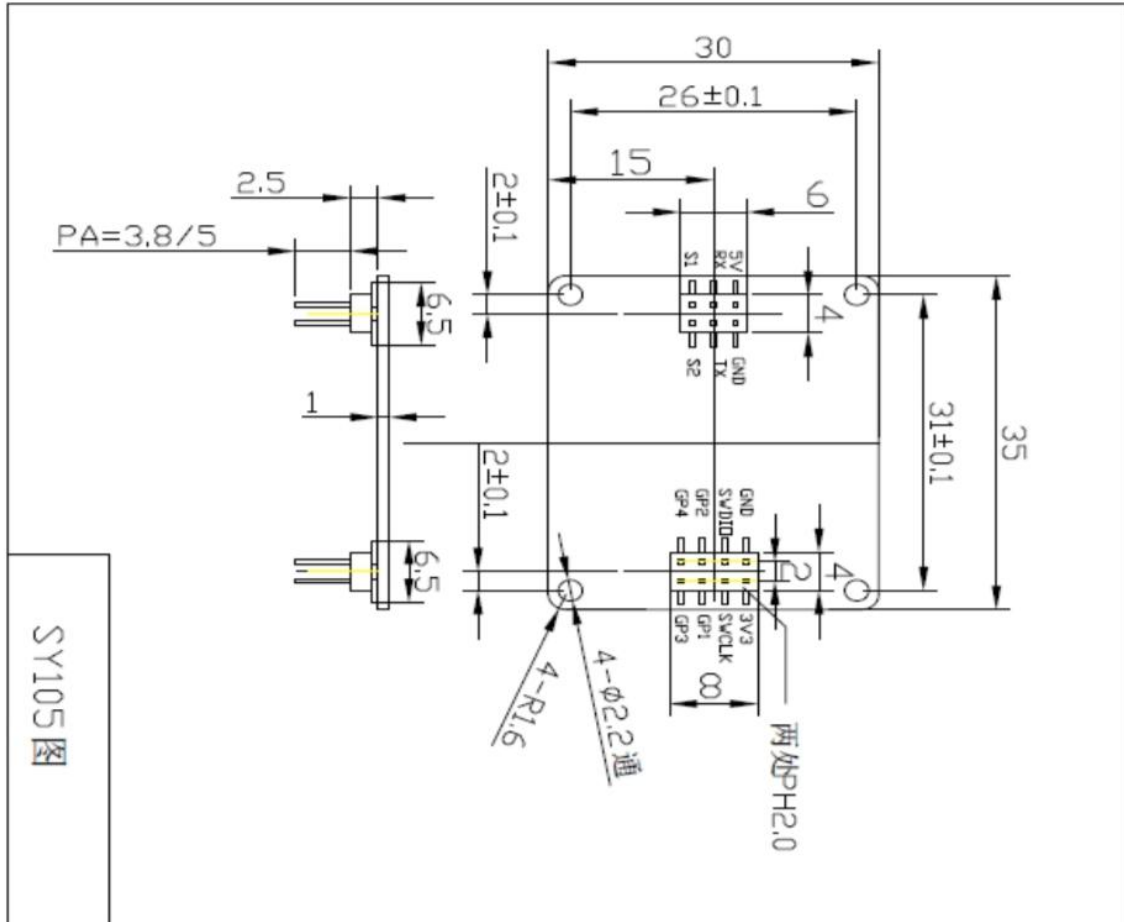

Fig.1 Schematic diagram of the radar module structure

3.2 Pin description

Interface	Pins	Description	Typical	Description
Interface 1	1	5V	5.0V	Power supply input positive
	2	GND		Ground
	3	RX		Serial port reception
	4	TX		Serial port transfer
	5	S1	3.3V/0V	
	6	S2	3.3V/0V	

Interface 2	1	3V3	3.3V	Output power
	2	GND		Ground
	3	SL		Reserved
	4	SD		Reserved
	5	GP1		Spare expansion pins
	6	GP2		Spare expansion pins
	7	GP3		Spare expansion pins
	8	GP4		Spare expansion pins

3.2 Using the wiring diagram

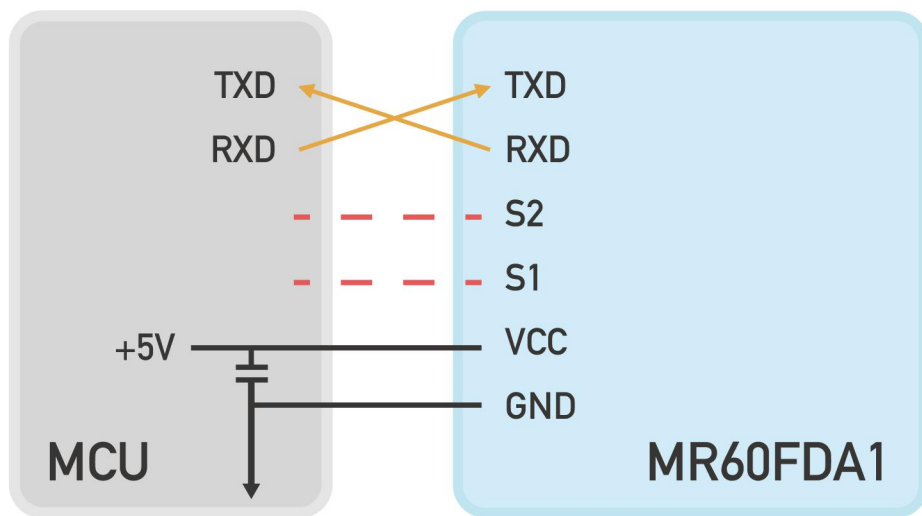
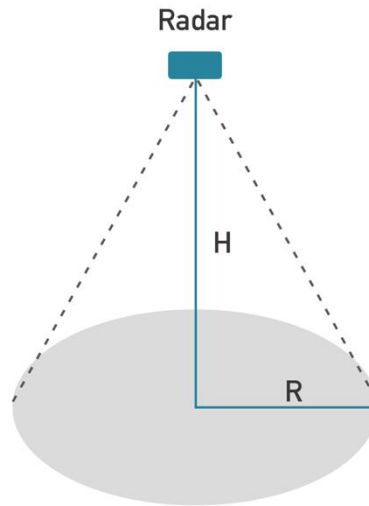

Fig.2 Schematic diagram of the radar module and peripheral connections

4. Main working properties

4.1 Radar module operating range

The beam coverage of the radar module is shown in the figure below. It covers a three-dimensional sector area having a horizontal angle of 100 degrees and 100 degrees incline.



Due to the characteristics of the radar's beam, it has a long-range coverage in the direction normal to the antenna surface but a short-range if it deviates from the normal direction of the antenna surface.

In addition, when the radar is mounted on top or inclined, its range will be reduced. This is due to the influence of its beam and effective radiation space. This should be put into consideration during usage.

4.2. main functions and performance

1. Main functions and performance
 - a. Fall detection function
 - i. Distance detection
 1. Radar projection radius when installed on the top $\leq 2\text{m}$
 2. Inclined installation, radar projection distance $\leq 4\text{m}$
 - ii. Accuracy: $\geq 90\%$
 2. Presence awareness
 - a. Detection distance: projection radius $\leq 3\text{m}$
 - b. Accuracy: $\geq 90\%$
 3. Motion detection function
 - a. Motion trigger
 - b. Motion direction and position perception

5. How the radar works and how it is installed

5.1. vertical mounting mode

The radar is installed on the roof and shines vertically downward.

Radar installation height is $h=2.4\text{m} \sim 3\text{M}$. With a radius of radar beam coverage area of R within the radar projection area, it is possible to further divide the projection area into areas for fall detection, presence detection, and motion detection. The Figure below illustrates a schematic diagram of the area.

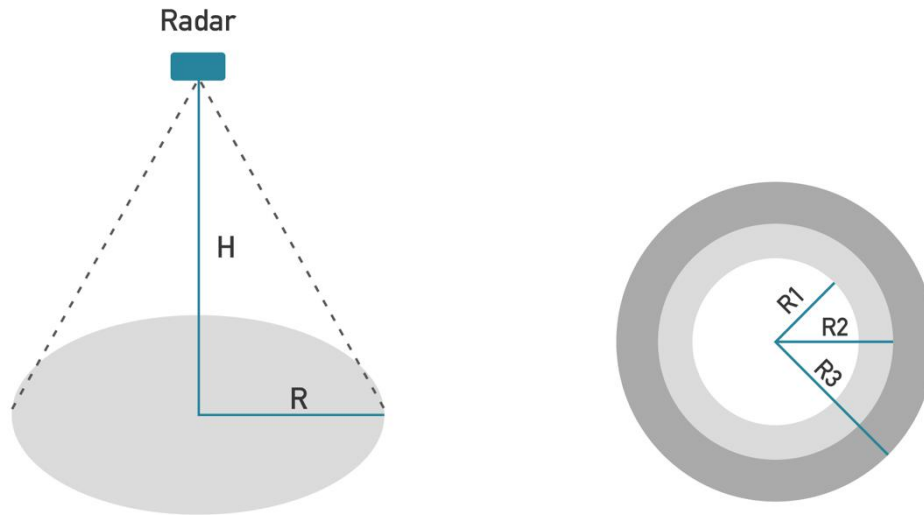

(a) Radar projection schematic (b) Schematic diagram of beam splitting

5.2. Tilt mounting mode

Certain scenarios require the radar to be installed obliquely, such as in a corner. For this type of installation method, the home gyroscope sensor on the radar determines the inclination of the radar and assists the radar in adjusting the angle.

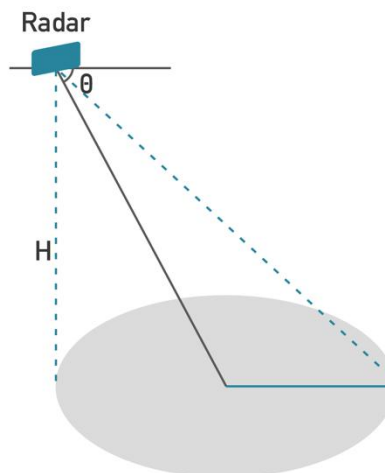

5.3. Horizontal mounting mode

Considering the number of channels of the current radar chip, the fall detection function is not considered for horizontal installation mode.

6. Typical applications

1. The product is appropriate for small-area scenes, including those in the bathroom, the bedroom, and the living room.
2. It is suitable for both inclined and top mounting.
3. The product is suitable for single or double occupancy.
4. The product must eliminate interference actions in consideration of application scenarios.