

SUMMIT-XL
AUTONOMOUS MOBILE ROBOT (AMR)



VERSATILITY & HIGH MOBILITY

INDOOR & OUTDOOR
APPLICATIONS

TWO KINEMATIC CONFIGURATIONS
WITH **RUBBER** OR **MECANUM**
WHEELS

RESEARCH & DEVELOPMENT

SURVEILLANCE

MILITARY

REMOTE MONITORING

ACCESS TO HAZARDOUS AREAS



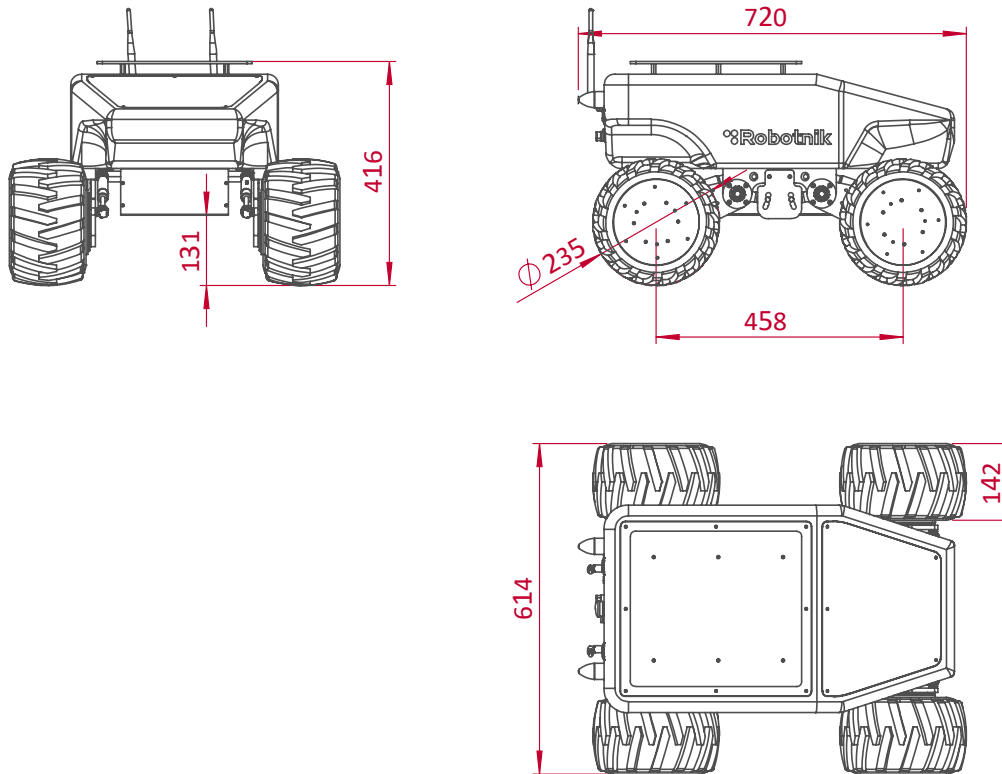

TECHNICAL SPECIFICATIONS

MECHANICAL

Dimensions	720 x 614 x 416 mm
Weight	65 Kg
Load capacity	65 Kg
Speed	3 m / s
Ambient	Indoor / Outdoor
Autonomy	10 h continuous motion
Batteries	LiFePO₄ 15Ah@48V
Traction system	4 wheels
Traction motors	4 x 500 W brushless servomotors
Temperature range	0° to +50°C
Max. slope	80 %

CONTROL

Controller	Open architecture ROS Integrated PC with Linux
Communication	WiFi 802.11n
Connectivity	Internal: USB, RS232 and GPIO External: USB, RJ45, 12 VDC and battery