

Hermes

General Purpose Robot Platform

Product Manual

- Small- to medium-sized robot development
- Highly adaptable and scalable
- Powerful optional functions

[Learn more >](#)



Table of Contents

1. Introduction	3
2. Introduction to Hermes Features	4
2.1 Autonomous Path-Finding	4
2.2 Robot Collaboration	4
2.3 Cross-Floor Delivery	4
2.4 Smart Obstacle Avoidance	4
2.5 Comprehensive Safety	4
2.6 Autonomous Recharging	5
3. Hermes Schematic Diagram	6
4. Hermes Charging Stand	7
5. Parameters.....	8
6. Commercial Scenarios	11
6.1 Restaurants and Ballrooms.....	11
6.2 Hotels	11
7. Case Study	12
7.1 Mercury 2 Food Delivery Robot	12
7.2 Mercury 2 Hotel Delivery Robot + Smart Elevator Control 3.0.....	12

1. Introduction

Developed by Slamtec, Hermes is a scalable and low-cost robot platform capable of meeting the needs of small-to medium-sized robot application development in areas such as smart patrol robots, container transportation robots, hotel delivery robots, food delivery robots, and more.

Autonomous Localization and Navigation

The built-in SLAMCUBE autonomous localization and navigation system kit enables path-finding and localization and navigation features to help robots figure out where they are, where they should go, and the best way to get there. Hermes is capable of performing a variety of tasks across different commercial environments.

Multi-Sensor Data Fusion

Multi-sensor data fusion technology is an effective way to improve the sensing capability of robotic systems. Hermes uses multi-sensor data fusion technology to effectively realize high degrees of autonomy and awareness in unpredictable environments. Fitted with equipment such as lidar, magnetic sensors, depth cameras, and bumper sensors, Hermes can implement autonomous mapping, localization, and navigation by flexibly responding to complex and ever-changing operational environments.



2. Introduction to Hermes Features

2.1 Autonomous Path-Finding

The built-in SLAMCUBE autonomous localization and navigation system kit enables path-finding and localization and navigation features to help robots figure out where they are, where they should go, and the best way to get there. Hermes is capable of performing a variety of tasks across different commercial environments. Hermes is capable of autonomous localization and path-finding in accordance with task target points, implementing autonomous movement.

2.2 Robot Collaboration

Hermes supports multi-robot collaboration to meet the needs of multi-task operations in complex environments during peak periods. Hermes supports local area network (LAN) and cloud platform collaborative operations, along with the dynamic adjustment of both speed and delivery routes in accordance with the environment to realize efficient, safe, and reliable multi-point delivery.

2.3 Cross-Floor Delivery

The Smart Elevator Control 3.0 system provides accurate detection of elevator statuses along with call-control functionality to provide efficient and reliable solutions that help hotel delivery robots autonomously navigate elevators in cross-floor scenarios. Through our API interfaces, Smart Elevator Control 3.0, as a relatively independent set of solutions, can also be integrated with other smart devices or third-party applications to meet the differentiated customization needs of customers.

2.4 Smart Obstacle Avoidance

The multi-sensor fusion technology of Hermes provides rapid and accurate identification of surrounding active environments, enabling smart obstacle avoidance and greatly reducing the chances of safety incidents.

2.5 Comprehensive Safety

Hermes uses multi-sensor fusion methods such as dual-depth cameras, bumper sensors, and lidar to accurately identify and avoid both moving and static obstacles. The robot also supports fall avoidance, collision avoidance, and emergency braking functionality to ensure comprehensive safety during the move process.

2.6 Autonomous Recharging

Sufficient power is ensured for Hermes to complete assigned tasks smoothly. Hermes automatically returns to the charging station when its battery charge falls below a configured threshold or when its tasks are completed.

3. Hermes Schematic Diagram

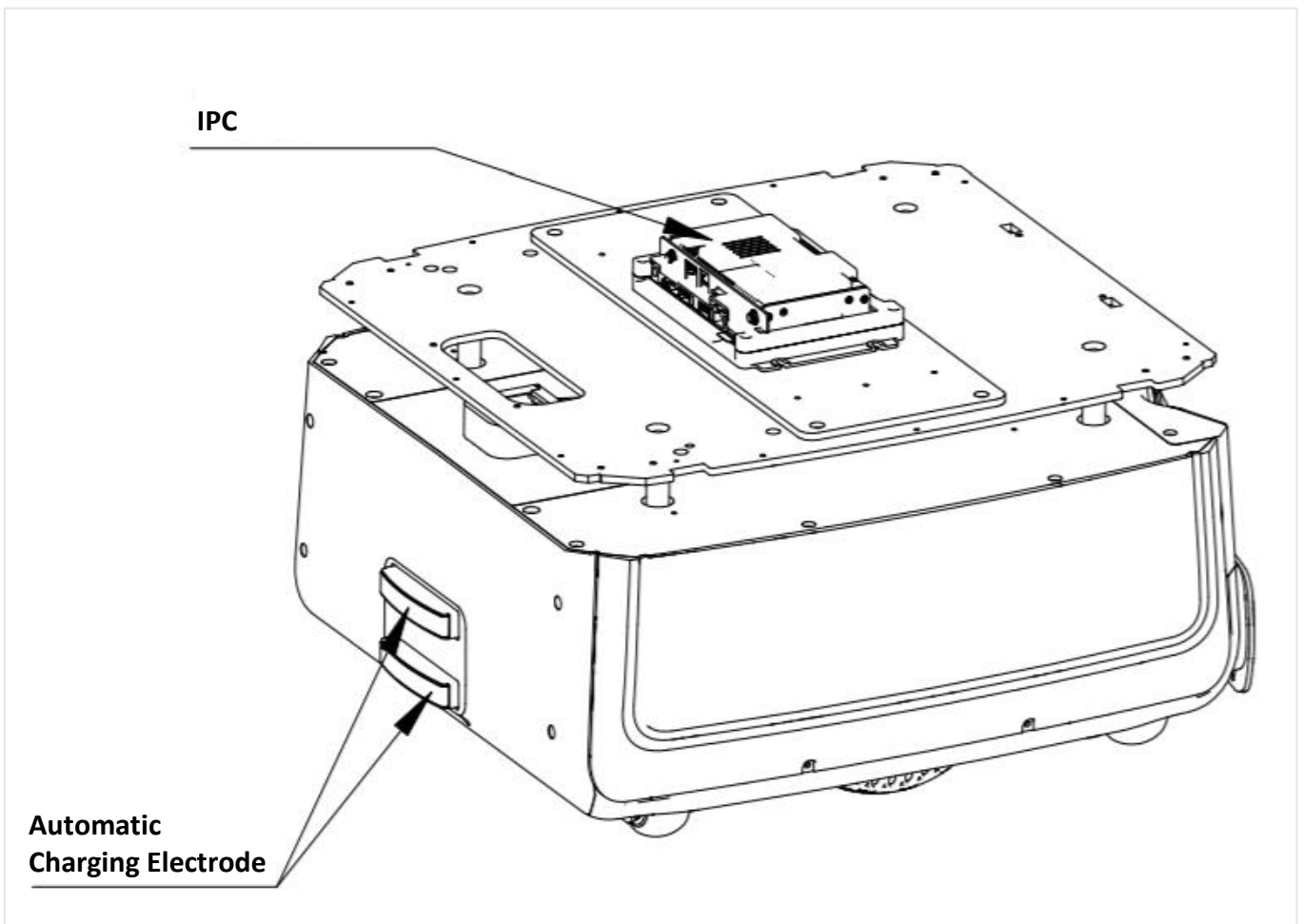
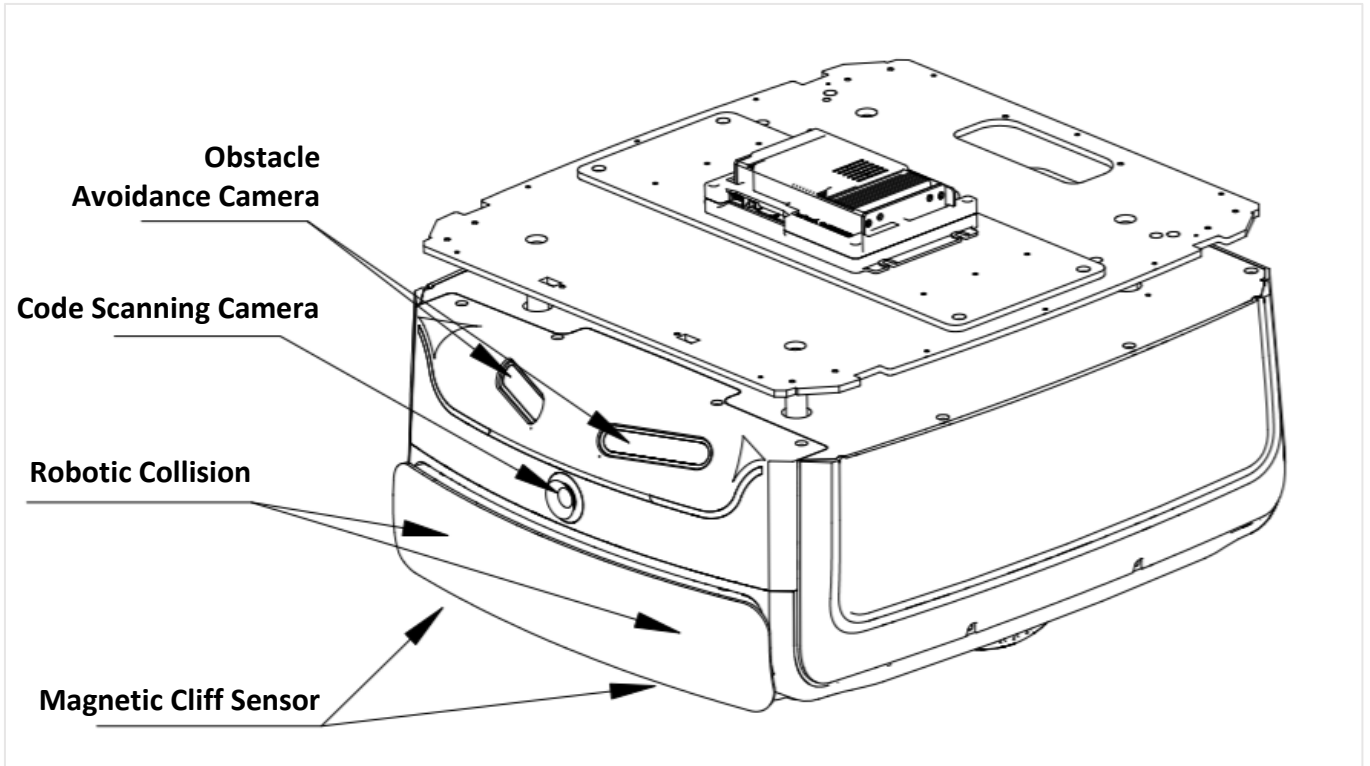

4. Hermes Charging Stand

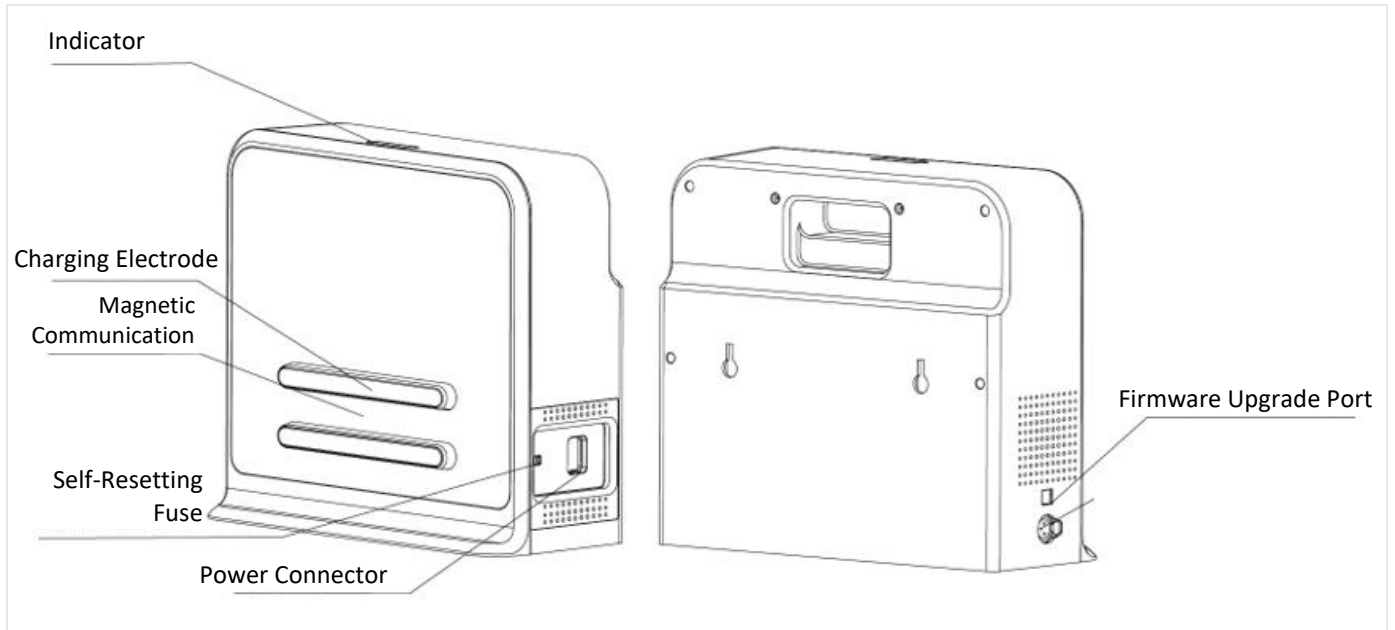

5. Parameters

Name		Hermes		
Core Features		SLAM Localization and Navigation		
Item		Index	Value	
Mass and Volume		Length x Width	545 x 465 mm	
		Height	272 mm (excludes controller)	
		Weight	40 kg (excludes controller)	
		Max Load	60 kg	
Sensor Performance Parameters	Lidar Sensor	Max Scan Radius (90% Surface Reflective Rate)	25 m, 360° (standard) 30 m, 360° (optional)	
		Depth Camera Sensor	Quantity	2 units
	Detection Range		0.2m-10m	
	Field of View (FOV)		Single H: 87° V: 58° Double H: 168° V: 58°	
	Boundary Sensor	Quantity	2 units	
		Max Detection Range	3.5cm	
	Bumper Sensor	Quantity	2 units	
		Trigger Method	Physical Collision	
	Mapping Performance		Map Resolution	5 cm
			Max Mapping Area	500m x 500m
Motion Parameters		Max Move Speed	1.2m/s (Can be customized 1.5 m/s)	
		Max Cross Slope	16°	
		Passing Obstacle Height	2 cm	
		Passing Obstacle Width	4 cm	
User Port	Hardware Port	Ethernet	1x RJ45 Gigabit Ethernet Port	
		Power Connector	DC 24V 9.5A DC12V 2A	
		Wi-Fi	2.4 GHz	

		4G	1x 4G
		SIM card slot	1 unit
		HDMI	1x HDMI
		Audio	1x 3.5mm Headset Socket 1x LINE_MIC Audio Jack (Co-lay with headset socket) 1x Dual-Channel 5w/8Ω Amplifier Jack
	Type-C	Standard USB 3.0 Type-C Port	
	Software API	SLAMWARE™	/
Battery and Capacity	Capacity Specifications	16 Ah (Standard) 25 Ah (Optional)	
	No-Load Operating Time	9.5h (16Ah) 15h (25Ah)	
	Charging Time	3h-4h	
	Battery Life	800 charges	
Power Consumption	Standby power consumption	32W (16Ah, No-load)	
	Motion power consumption	39W (No-load)	
	Full load power consumption	32W (Standby) 62W (Motion)	
	Maximum access power consumption	200W	
	Rated output	DC25.5V 2A	
Wheelset	Wheelset Parameters	6.5-inch In-Wheel Motor	
Noise	Working noise	≤50dB	
Operating Environment	Operating Temperature	0°C to +40°C	
	Transportation and storage conditions	-25 °C to +55°C	
	Operating Humidity	30 to 70%rh (no condensation)	
	Height above sea level	≤2000m	

Charging point	
Name	Parameters
Size	360mm*150mm*320mm
Color	White
Rated input	100-240V 50/60Hz 3A MAX
Rated output	DC 25.5V 6A
Rated input frequency	50/60Hz

6. Commercial Scenarios

6.1 Restaurants and Ballrooms

In addition to improving service efficiency, food delivery robots reduce labor costs and deliver specialized solutions. The product provides welcome reception, self-service ordering, multi-point delivery, and other functionality that can be customized in accordance with customer requirements to realize product diversification and realize corporate competitiveness.



6.2 Hotels

Commercial smart delivery robots can be used to replace labor, reduce operating costs, and improve service efficiency. The product enables ordering by smartphone, unified cloud platform management, real-time equipment response, smart elevator controls, and other functionality to realize autonomous cross-floor robot delivery. Through autonomous smart operations and data-driven optimized management, we deliver brand differentiation for hotels and commercial buildings, enhancing corporate competitiveness.



7. Case Study

7.1 Mercury 2 Food Delivery Robot



7.2 Mercury 2 Hotel Delivery Robot + Smart Elevator Control 3.0

