

1x80A and 1x120A Single Channel Brushed DC Motor Controller with Encoder Input, USB and CAN



Roboteq's MDC1230 and MDC1460 controllers are designed to convert commands received from an RC radio, Analog Joystick, wireless modem, PC (via RS232) or microcomputer into high voltage and high current output for driving one DC motor. Using CAN bus, up to 127 controllers can be networked on a single twisted pair. Numerous safety features are incorporated into the controller to ensure reliable and safe operation.

The controller features a high-performance 32-bit microcomputer and quadrature encoder inputs to perform advanced motion control algorithms in Open Loop or Close Loop (Speed or Position) modes. The MDC1xxx features several Analog, Pulse and Digital I/Os which can be remapped as command or feedback inputs, limit switches, or many other functions.

Numerous safety features are incorporated into the controller to ensure reliable and safe operation. The controller's operation can be extensively automated and customized using Basic Language scripts. The controller can be reprogrammed in the field with the latest features by downloading new operating software from Roboteq.

Applications

- Industrial Automation
- Fan & Pump control
- Winch & Cranes
- Personal transportation
- Automatic Guided Vehicles
- Terrestrial and Underwater Robotic Vehicles
- Automated machines
- Telepresence Systems
- Animatronics

Features List

- RS232, 0-5V Analog, or Pulse (RC radio) command modes
- Auto switch between RS232, Analog, or Pulse based on user-defined priority
- CAN bus interface at up to 1Mbit/s
- Built-in high-power power drivers for one DC motor at up to 80A (MDC1230) and 120A (MDC1460)
- Full forward & reverse control. Four quadrant operation. Supports regeneration
- Operates from a single power source
- Built-in programming language for automation and customization
- Programmable current limit up to 80A (MDC1230) or 120A (MDC1460) for protecting controller, motors, wiring and battery
- Up to 6 Analog Inputs for use as command and/or feedback
- Up to 6 Pulse Length, Duty Cycle or Frequency Inputs for use as command and/or feedback
- Up to 6 Digital Inputs for use as Deadman Switch, Limit Switch, Emergency stop or user inputs
- Quadrature Encoder input with 32-bit counter
- 2 general purpose 24V, 1A output for brake release or accessories
- Selectable min, max, center and deadband in Pulse and Analog modes
- Selectable exponentiation factors for each command inputs
- Trigger action if Analog, Pulse or Encoder capture are outside user selectable range (soft limit switches)
- Open loop or closed loop speed control operation
- Closed loop position control with analog or pulse/frequency feedback

- Precise speed and position control when Encoder feedback is used
- PID control loop
- Configurable Data Logging of operating parameters on RS232 Output for telemetry or analysis
- Built-in Battery Voltage and Temperature sensors
- Power Control input for turning On or Off the controller from external microcomputer or switch
- No consumption by output stage when motors stopped
- Regulated 5V output for powering Encoders, RC radio, RF Modem or microcomputer
- Programmable acceleration and deceleration
- Programmable maximum forward and reverse power
- Ultra-efficient 6 mOhm (MDC1230) or 3 mOhm (MDC1460) ON resistance MOSFETs
- Stall detection and selectable triggered action if Amps is outside user-selected range
- Overvoltage and Undervoltage protection
- Programmable Watchdog for automatic motor shutdown in case of command loss
- Overtemperature protection
- Diagnostic LED
- Efficient heat sinking using conduction bottom plate. Operates without a fan in most applications
- Power wiring via FASTON terminals
- Open frame or enclosed design with heat conducting bottom plate
- 5.50" (140mm) L, 4.45" W (113mm), 0.78" (20mm) H
- -40o to +85o C operating environment
- 3.5oz (100g)
- Easy configuration, tuning and monitory using provided PC utility
- Field upgradeable software for installing latest features via the internet

Orderable Product References

TABLE 1.

Reference	Number of Channels	Amps/Channel	Volts
MDC1230	1	80	30
MDC1460	1	120	60

Important Safety Disclaimer

Dangerous uncontrolled motor runaway condition can occur for a number of reasons, including, but not limited to: command or feedback wiring failure, configuration error, faulty firmware, errors in user script or user program, or controller hardware failure.

The user must assume that such failures can occur and must make his/her system safe in all conditions. Roboteq will not be liable in case of damage or injury as a result of product misuse or failure.

Power Wires Identifications and Connection

Power connections are made through FASTON tabs. For more power handling the Supply and Motor tabs are doubled and should be connected in parallel.

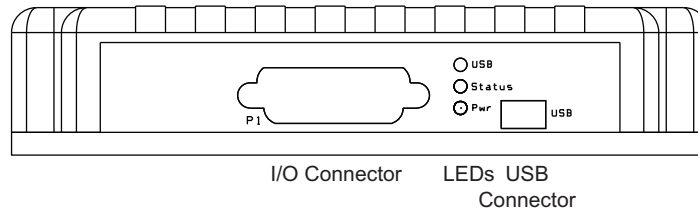
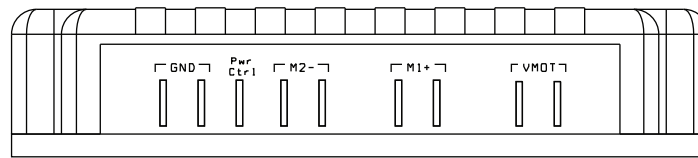

FIGURE 1. MDC1xxx front view



Power Supply and Motor Connections

FIGURE 2. MDC1xxx rear view

The diagram below shows how to wire the controller and how to turn power On and Off.

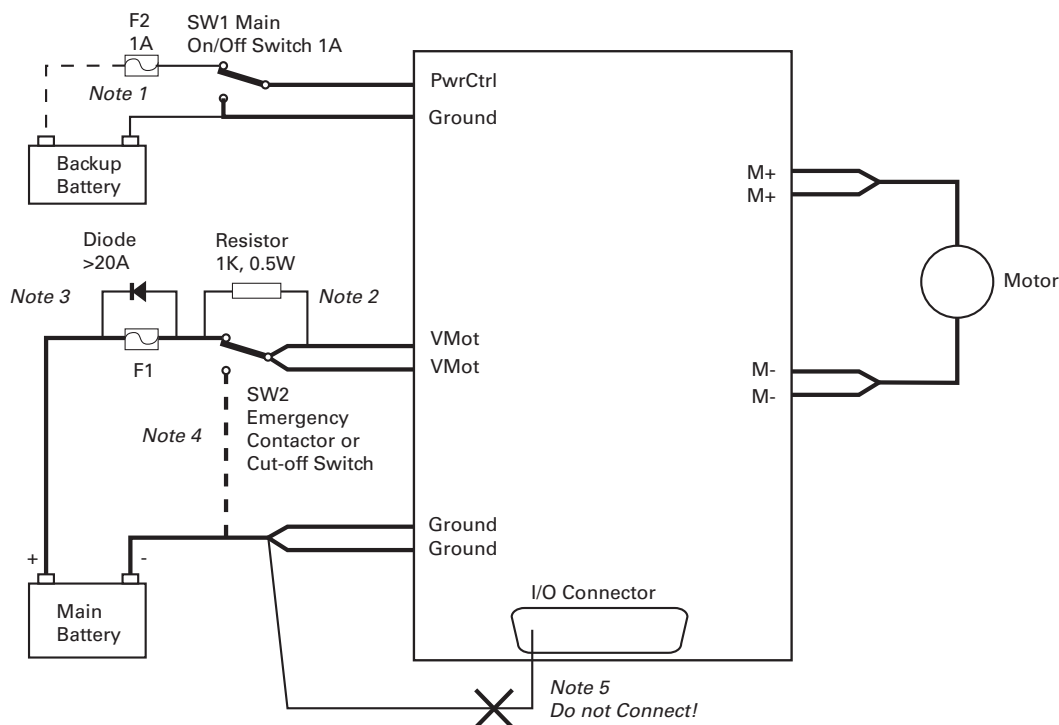

FIGURE 3. Powering the controller. Thick lines identify **MANDATORY** connections

Important Warning

Carefully follow the wiring instructions provided in the Power Connection section of the User Manual. The information on this datasheet is only a summary.

Mandatory Connections

It is imperative that the controller is connected as shown in the above diagram in order to ensure a safe and trouble-free operation. All connections shown as thick black lines are mandatory. The controller must be powered On/Off using switch SW1 on the Power Control Header.

Emergency Switch or Contactor

The battery must be connected in permanence to the controller's VMot power via an input emergency switch or contactor SW2 as additional safety measure. The user must be able to deactivate the switch or contactor at any time, independently of the controller state.

Precautions and Optional Connections

Note 1: Optional backup battery to ensure motor operation with weak or discharged battery.

Note 2: Use precharge 1K Resistor to prevent switch arcing.

Note 3: Insert a high-current diode to ensure a return path to the battery during regeneration in case the fuse is blown.

Note 4: Optionally ground the VMot wires when the controller is Off if there is any concern that the motors could be made to spin and generate voltage in excess of 30V (MDC1230) or 60V (MDC1460).

Note 5: Beware not to create a path from the ground pins on the I/O connector and the battery's minus terminal.

Use of Safety Contactor for Critical Applications

An external safety contactor must be used in any application where damage to property or injury to person can occur because of uncontrolled motor operation resulting from failure in the controller's power output stage.

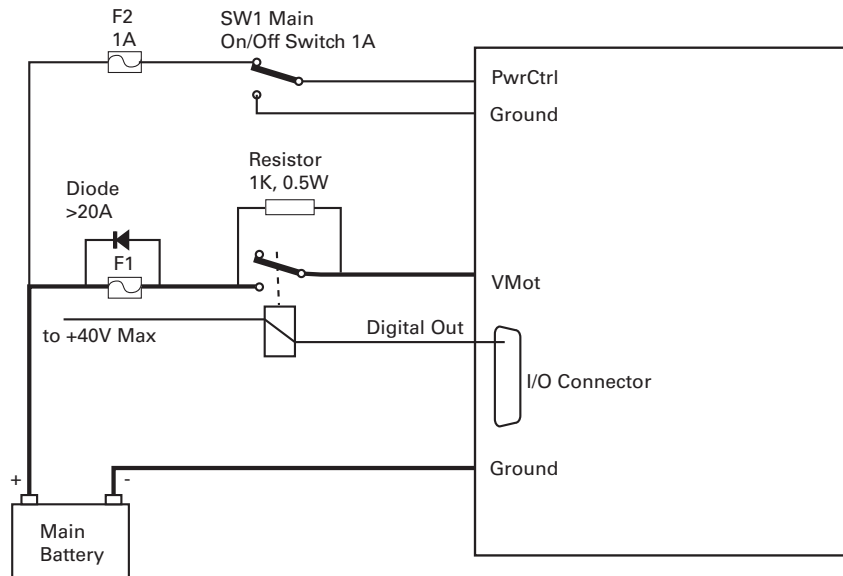

FIGURE 4. Contactor wiring diagram

The contactor coil must be connected to a digital output configured to activate when “No MOSFET Failure.” The controller will automatically deactivate the coil if the output is expected to be off and battery current of 2.5A or more is measured for more than 0.5s. This circuit will not protect against other sources of failure such as those described in the “Important Safety Disclaimer” on page 3.

Controller Mounting

During motor operation, the controller will generate heat that must be evacuated. The published amps rating can only be fully achieved if adequate cooling is provided. Mount the controller so that the bottom plate makes contact with a metallic surface (chassis, cabinet) to conduct the heat.

Sensor and Commands Connection

Connection to RC Radio, Microcomputer, Joystick and other low current sensors and actuators is done via the 15 connector located in front of the board. The functions of many pins vary depending on user configuration. Pin assignment is found in the table below.

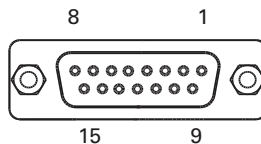

FIGURE 5. Connector pin locations

TABLE 2.

Connector Pin	Power	Dout	Com	RC	Ana	Dinput	Enc	Default Config
1		DOUT1						Brake
9		DOUT2						Contactator
2			TxOut					RS232Tx
10				RC5	ANA5 (1)	DIN5	ENCA (2)	Encoder (2)
3			RxIn					RS232Rx
11				RC4	ANA4	DIN4		AnaCmd (3)
4				RC1	ANA1 (1)	DIN1		RCRadio1
12				RC3	ANA3	DIN3		Unused
5	GND							
13	GND							
6			CANL					CAN Low
14	5VOut							
7			CANH					CAN High
15				RC6 (1)	ANA6	DIN6	ENCB (2)	Encoder (2)
8				RC2	ANA2	DIN2		Unused

Note 1: Pin assignment for this signal may differ from other Roboteq controller models.
 Note 2: Encoder input requires RC inputs 3, 4, 5 and 6 to be disabled. Encoders are enabled in factory default.
 Note 3: Analog command is disabled in factory default configuration.

Default I/O Configuration

The controller can be configured so that practically any Digital, Analog and RC pin can be used for any purpose. The controller's factory default configuration provides an assignment that is suitable for most applications. The figure below shows how to wire the controller to one analog potentiometer, an RC radio, and the RS232 port. It also shows how to connect the output to a motor brake solenoid. You may omit any connection that is not required in your application. The controller automatically arbitrates the command priorities depending on the presence of a valid command signal in the following order: 1-RS232, 2-RC Pulse, 3-None. If needed, use the Roborun+ PC Utility to change the pin assignments and the command priority order.

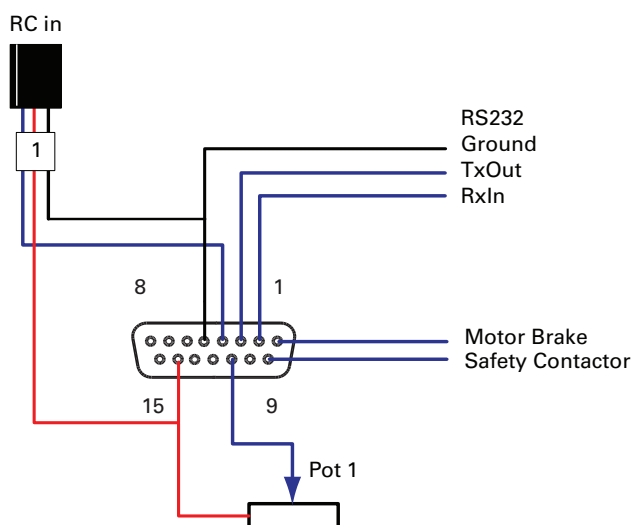

FIGURE 6. Factory default pins assignment

CAN Bus Operation

The controller can interface to a standard CAN Bus network, using 4 possible protocols: A simple and powerful meshed network (RoboCAN), Standard CANOpen, and two simplified proprietary schemes (MiniCAN and Raw-CAN). Please refer to the User Manual for details. USB and CAN cannot operate at the same time. The controller starts up with CAN available, but CAN will be disabled as soon as the controller is plugged into USB. To re-enable CAN, disconnect USB and restart the controller.

USB communication

Use USB only for configuration, monitoring and troubleshooting. USB is not a reliable communication method when used in a electrically noisy environments and communication will not always recover after it is lost without unplugging and replugging the connector, or restarting the controller. Always prefer RS232 communication when interfacing to a computer.

Enabling Analog Commands

For safety reasons, the Analog command mode is disabled by default. To enable the Analog mode, use the PC utility and set Analog in Command Priority 2 or 3 (leave Serial as priority 1). Note that by default the additional securities are enabled and will prevent the motor from starting unless the potentiometer is centered, or if the voltage is below 0.25V or above 4.75V. The drawing shows suggested assignment of Pot 1 to ANA1. Use the PC utility to enable and assign analog inputs.

Status LED Flashing Patterns

After the controller is powered on, the Power LED will tun on, indicating that the controller is On. The Status LED will be flashing at a 2 seconds interval. The flashing pattern provides operating or exception status information.

Additional status information may be obtained by monitoring the controller with the PC utility.

Electrical Specifications

Absolute Maximum Values

The values in the table below should never be exceeded. Permanent damage to the controller may result.

TABLE 3.

Parameter	Measure point	Model	Min	Typ	Max	Units
Battery Leads Voltage	Ground to VMot	MDC1230	10		35	Volts
		MDC1460	10		62	Volts
Reverse Voltage on Battery Leads	Ground to VMot	All	-1			Volts
Motor Leads Voltage	Ground to M+, M-	MDC1230			30	Volts
		MDC1460			62	Volts
Digital Output Voltage	Ground to Output pins	All			40	Volts
Analog and Digital Inputs Voltage	Ground to any signal pin on 15-pin connectors	All			15	Volts
RS232 I/O pins Voltage	External voltage applied to Rx/Tx pins	All			15	Volts
Board Temperature	Board	All	-40		85	oC
Humidity	Board	All			100 (2)	%

TABLE 3.

Parameter	Measure point	Model	Min	Typ	Max	Units
Note 1: Maximum regeneration voltage in normal operation. Never inject a DC voltage from a battery or other fixed source						
Note 2: Non-condensing						

Power Stage Electrical Specifications (at 25oC ambient)

TABLE 4.

Parameter	Measure point	Model	Min	Typ	Max	Units
Battery Leads Voltage	Ground to VMot	MDC1230	10 (1)		30	Volts
		MDC1460	10 (1)		62	Volts
Motor Leads Voltage	Ground to M+, M-	MDC1230	0 (1)		30 (2)	Volts
		MDC1460	0 (1)		62 (2)	Volts
Over Voltage protection range	Ground to VMot	MDC1230	5	30 (4)	35 (2)	Volts
		MDC1460	5	50 (4)	62 (2)	Volts
Under Voltage protection range	Ground to VMot	MDC1230	0	5 (4)	30	Volts
		MDC1460	0	5 (4)	62	Volts
Idle Current Consumption	VMot or Pwr Ctrl wires	All	50	75 (5)	100	mA
ON Resistance (Excluding wire resistance)	VMot to M+, plus M- to Ground at 100% power	MDC1230		6		mOhm
		MDC1460		3		mOhm
Max Current for 30s	Motor current	MDC1230			80 (6)	Amps
		MDC1460			120 (6)	Amps
Continuous Max Current	Motor current	MDC1230			50 (7)	Amps
		MDC1460			70 (7)	Amps
Current Limit range	Motor current	MDC1230	1	60 (8)	80	Amps
		MDC1460	1	80 (8)	120	Amps
Stall Detection Amps range	Motor current	MDC1230	1	60 (8)	80	Amps
		MDC1460	1	80 (8)	120	Amps
Stall Detection timeout range	Motor current	All	1	500 (9)	65000	milli-seconds
Motor Acceleration/Deceleration range	Motor current	All	100	500 (10)	65000	milli-seconds

Note 1: Negative voltage will cause a large surge current. Protection fuse needed if battery polarity inversion is possible

Note 2: Maximum regeneration voltage in normal operation. Never inject a DC voltage from a battery or other fixed source

Note 3: Minimum voltage must be present on VMot or Power Control wire

Note 4: Factory default value. Adjustable in 0.2V increments

Note 5: Current consumption is lower when higher voltage is applied to the controller's VMot or PwrCtrl wires

Note 6: Max value is determined by current limit setting. Duration is estimated and is dependent on ambient temperature cooling condition

Note 7: Estimate. Limited by heatsink temperature. Current may be higher with better cooling

Note 8: Factory default value. Adjustable in 0.1A increments

Note 9: Factory default value. Time in ms that Stall current must be exceeded for detection

Note 10: Factory default value. Time in ms for power to go from 0 to 100%

Beware that regenerative braking can create high voltage at the controller's power inputs. Use the controller only with batteries. See user manual for special precautions when using a power supply.

Command, I/O and Sensor Signals Specifications

TABLE 5.

Parameter	Measure point	Min	Typ	Max	Units
Main 5V Output Voltage	Ground to 5V pin on DSub15	4.7	4.9	5.1	Volts
5V Output Current	5V pin on DSub15			100	mA
Digital Output Voltage	Ground to Output pins			40	Volts
Digital Output Current	Output pins, sink current			1	Amps
Output On resistance	Output pin to ground		0.75	1.5	Ohm
Output Short circuit threshold	Output pin	1.05	1.4	1.75	Amps
Input Impedances	AIN/DIN Input to Ground		53		kOhm
Digital Input 0 Level	Ground to Input pins	-1		1	Volts
Digital Input 1 Level	Ground to Input pins	3		15	Volts
Analog Input Range	Ground to Input pins	0		5.1	Volts
Analog Input Precision	Ground to Input pins		0.5		%
Analog Input Resolution	Ground to Input pins		1		mV
Pulse durations	Pulse inputs	20000		10	us
Pulse repeat rate	Pulse inputs	50		250	Hz
Pulse Capture Resolution	Pulse inputs		1		us
Frequency Capture	Pulse inputs	100		10000	Hz
Encoder count	Internal	-2.147		2.147	10 ⁹ Counts
Encoder frequency	Encoder input pins			1M(1)	Counts/s

Note1: Encoder input requires RC inputs 3, 4, 5 and 6 to be disabled. Encoders are enabled in factory default.

Operating & Timing Specifications

TABLE 6.

Parameter	Measure Point	Min	Typ	Max	Units
Command Latency	Command to output change	0	0.5	1	ms
PWM Frequency	Motor outputs	10	18 (1)	20	kHz
Closed Loop update rate	Internal		1000		Hz
RS232 baud rate	Rx & Tx pins		115200 (2)		Bits/s
RS232 Watchdog timeout	Rx pin	1 (3)	1000	65000	ms

Note 1: May be adjusted with configuration program
 Note 2: 115200, 8-bit, no parity, 1 stop bit, no flow control
 Note 3: May be disabled with value 0

Scripting

TABLE 7.

Parameter	Measure Point	Min	Typ	Max	Units
Scripting Flash Memory	Internal		8196		Bytes
Max Basic Language programs	Internal		1000		Lines
Integer Variables	Internal			1024	Words (1)
Boolean Variables	Internal			1024	Symbols
Execution Speed	Internal		50000		Lines/s
Note 1: 32-bit words					

Thermal Specifications

TABLE 8.

Parameter	Measure Point	Min	Typ	Max	Units
Board Temperature	PCB	-40		85 (1)	oC
Thermal Protection range	PCB	70		80 (2)	oC
Thermal resistance	Power MOSFETs to heats sink			2	oC/W
Note 1: Thermal protection will protect the controller power					
Note 2: Max allowed power out starts lowering at minimum of range, down to 0 at max of range					

The MDC1xxx uses a conduction plate at the bottom of the board for heat extraction. For best results, attach firmly with thermal compound paste against a metallic chassis so that heat transfers to the conduction plate to the chassis. If no metallic surface is available, mount the controller on spacers so that forced or natural air flow can go over the plate surface to remove heat.

Mechanical Specifications

TABLE 9.

Parameter	Measure Point	Min	Typ	Max	Units
Weight	Board		100 (3.5)		g (oz.)
Power Wire Gauge	FASTON tabs			10	AWG

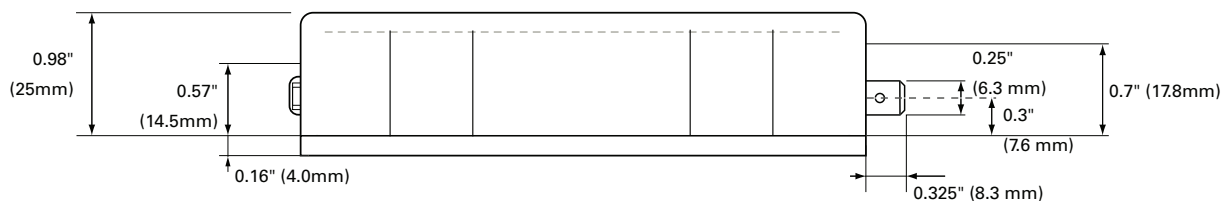

FIGURE 7. MDC1xxx side view and dimensions

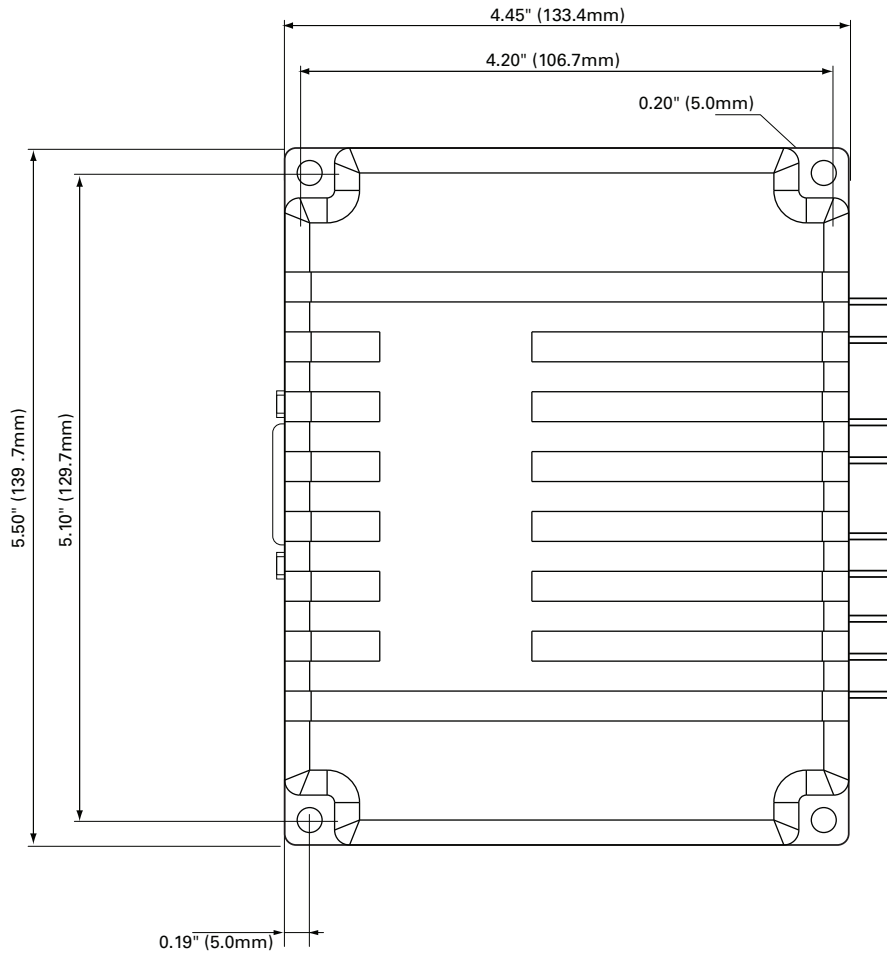

FIGURE 8. MDC