

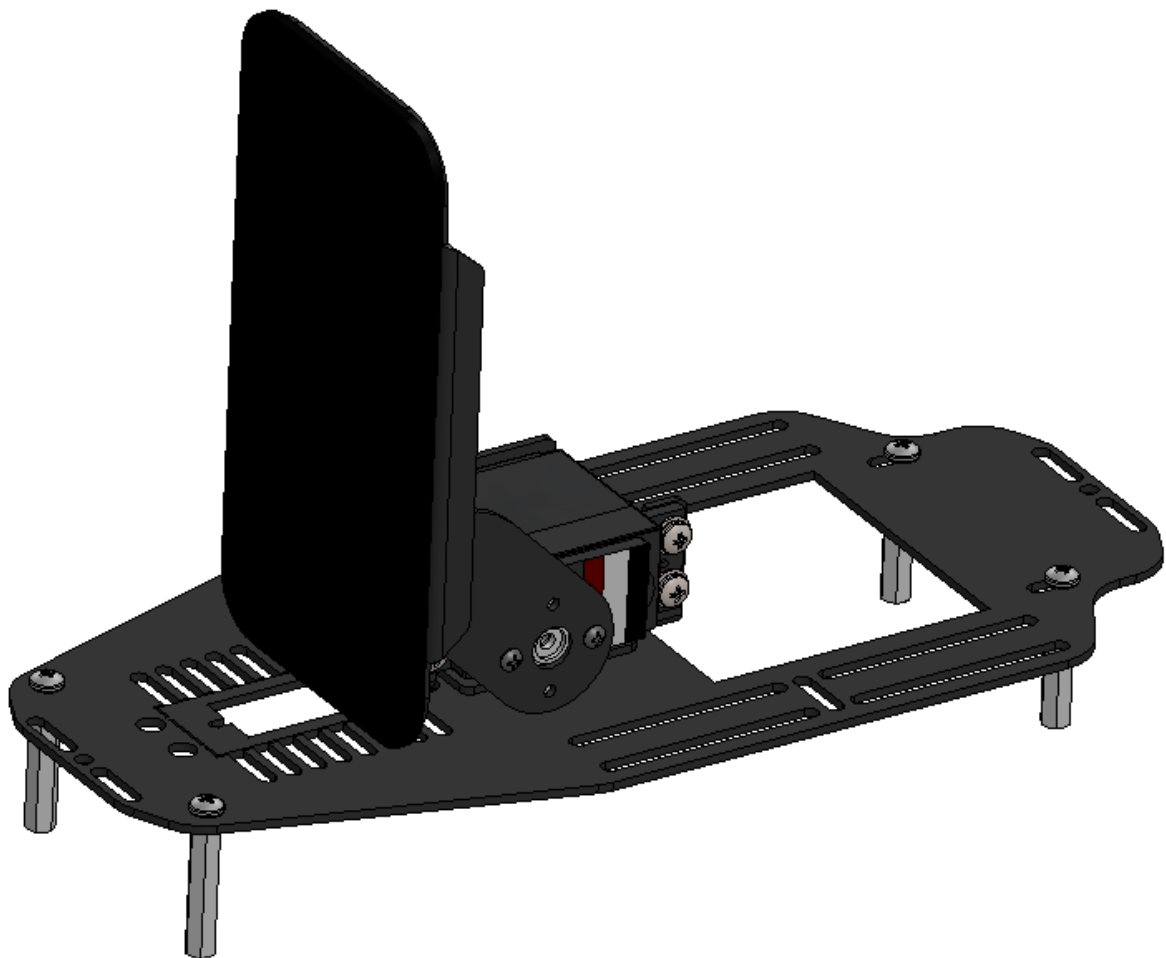

## ROVER



### DFRobotShop Rover Cell Phone Expansion Plate Setup

This guide is only available in English

This guide assumes you have assembled the DFRobotShop Rover as per the default configuration: <https://www.youtube.com/watch?v=MWWoEul9Qsk>

## STEP 1

Break four connection points to free up the opening for the shield.

This is done to allow for unobstructed access to make connections to the IO shield.

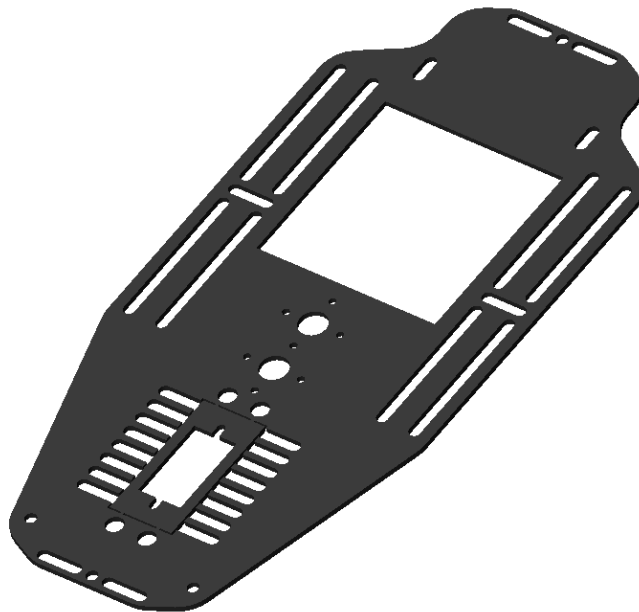
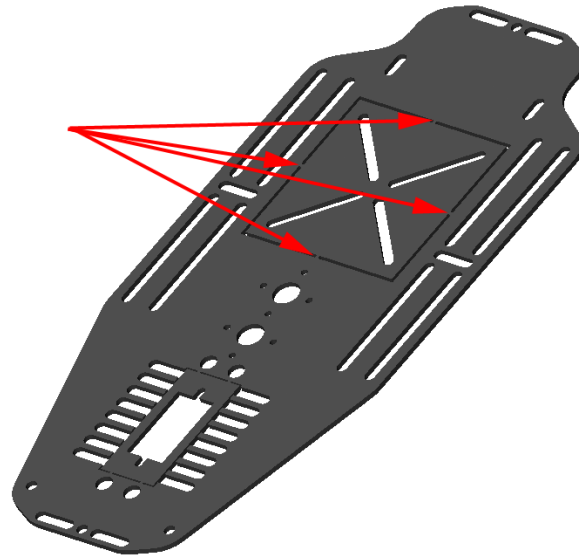

## STEP 2 (Two options)

Option 1) Attach the expansion plate using four 3mm screws as shown.

Option 2) Attach the hex standoffs to the DFRobotShop Rover screws (preferable). Note that the heads of the screws should be below the PCB; if not, reassemble to have the threaded part facing upward.

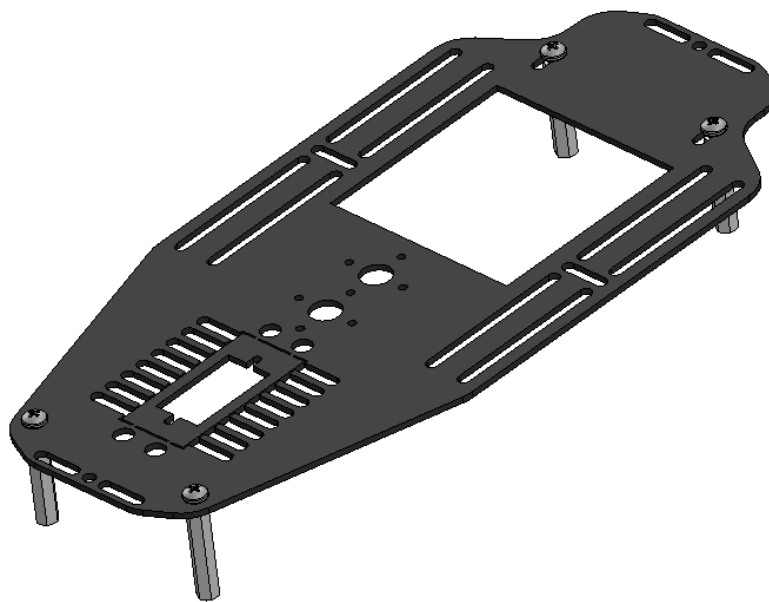
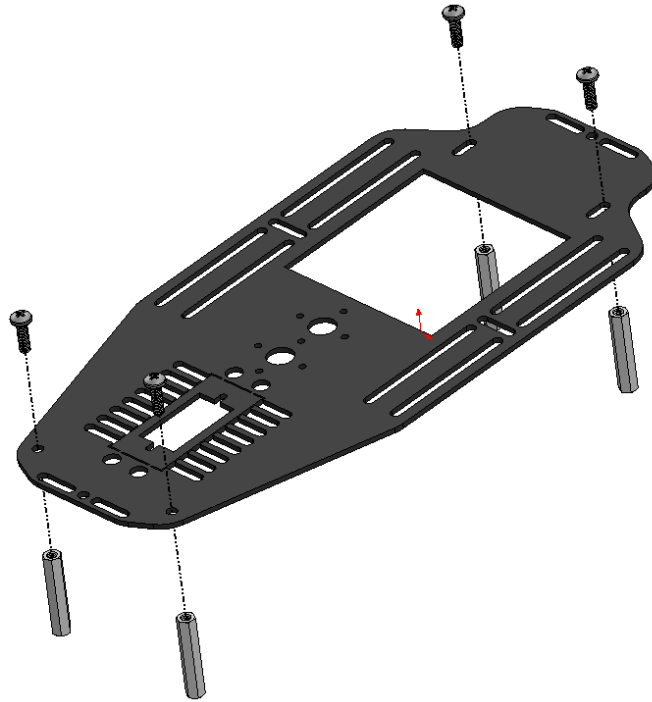

### STEP 3

Connect the multipurpose bracket using two 2-56 machine screws and two 2-56 nuts.

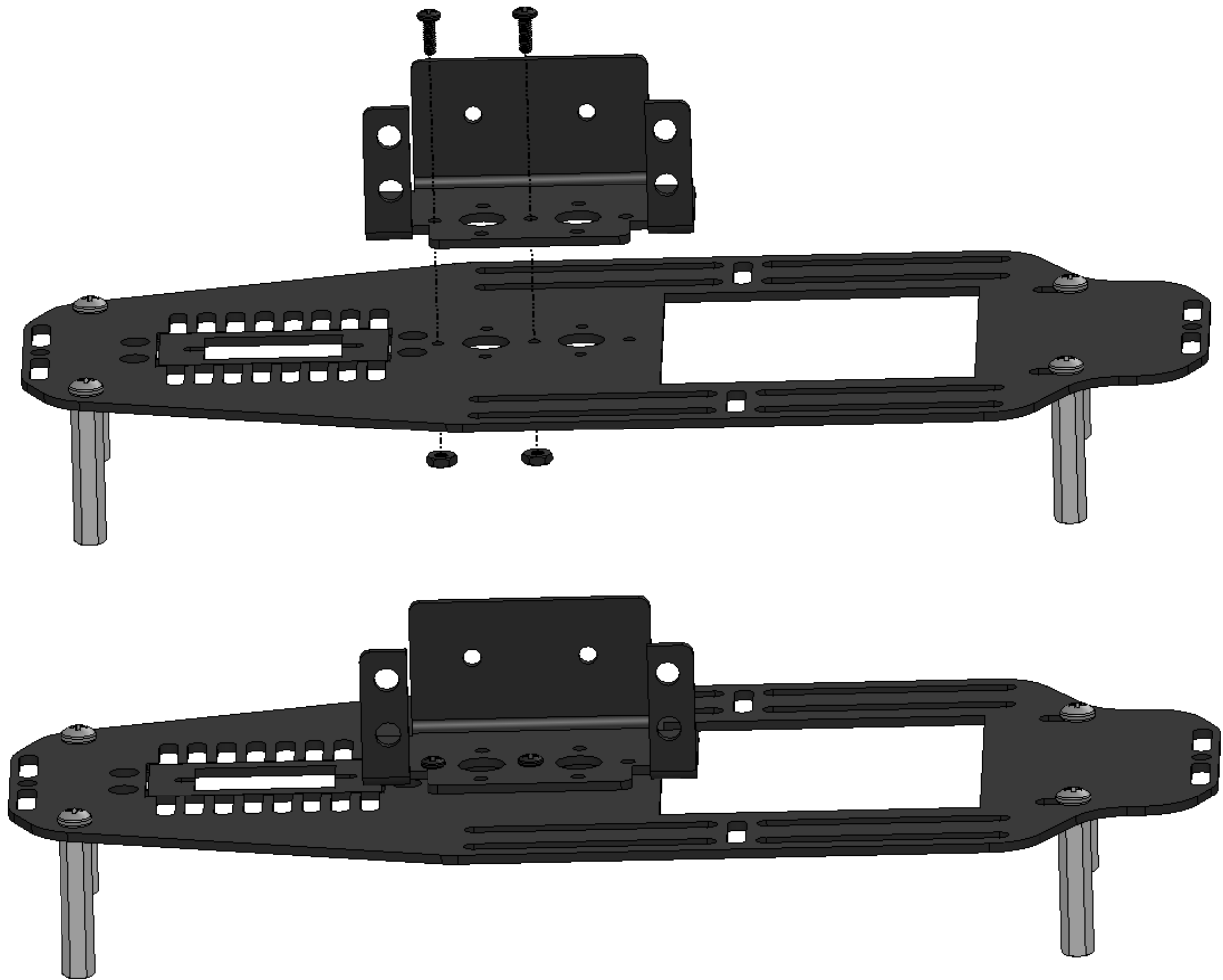

## STEP 4

Add ball bearing using the ball bearing hardware

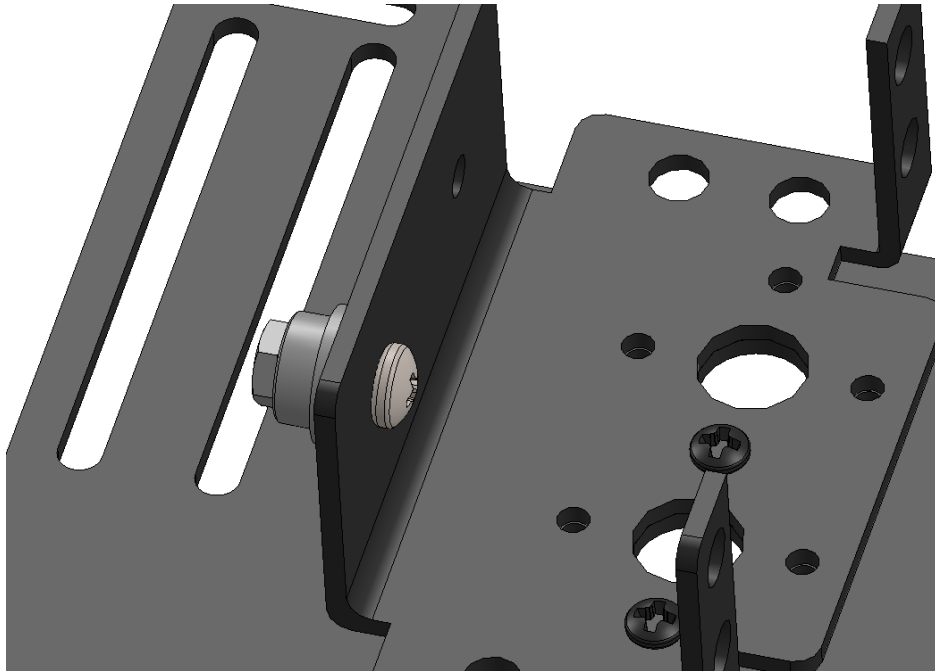
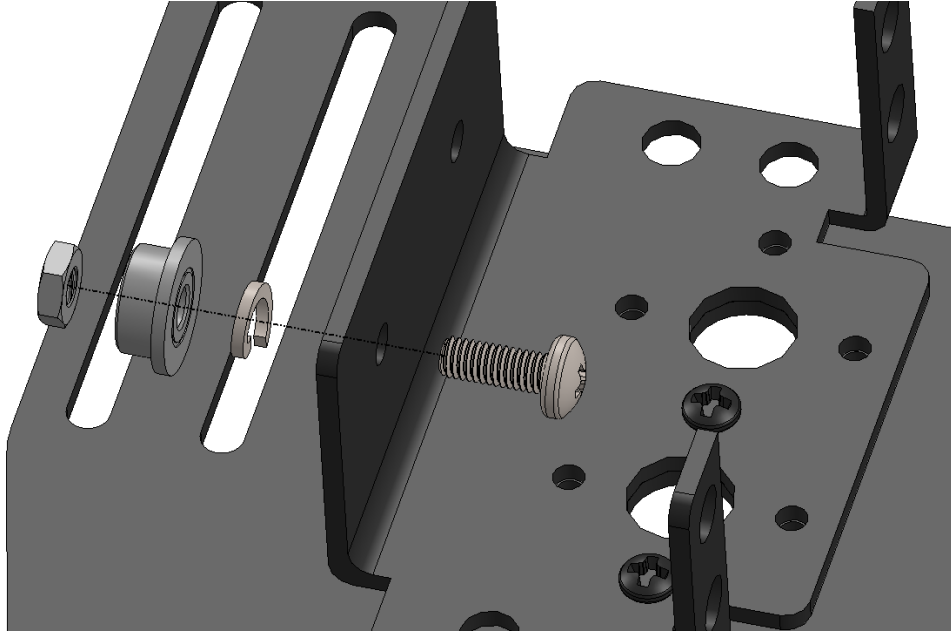

## STEP 5

Connect the servo to the multipurpose bracket using the servo mounting hardware provided.

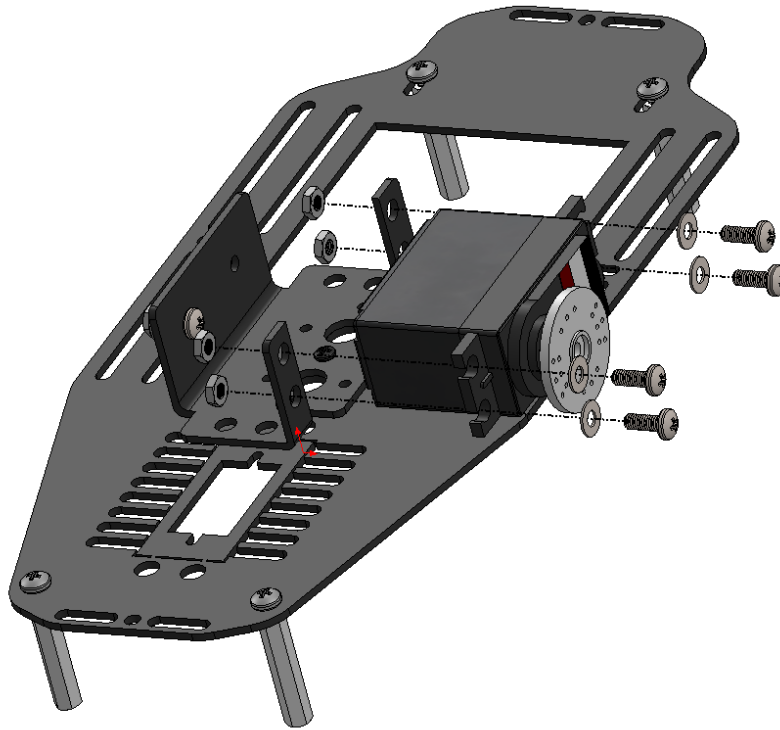

## STEP 6

Connect the ARF-01 flat bracket to the angled bracket to create the “tilt bracket”.

Use two 2-56 counter-sunk screws and two 2-56 nuts.

It is important to use the lower SES hole pattern on the flat bracket.

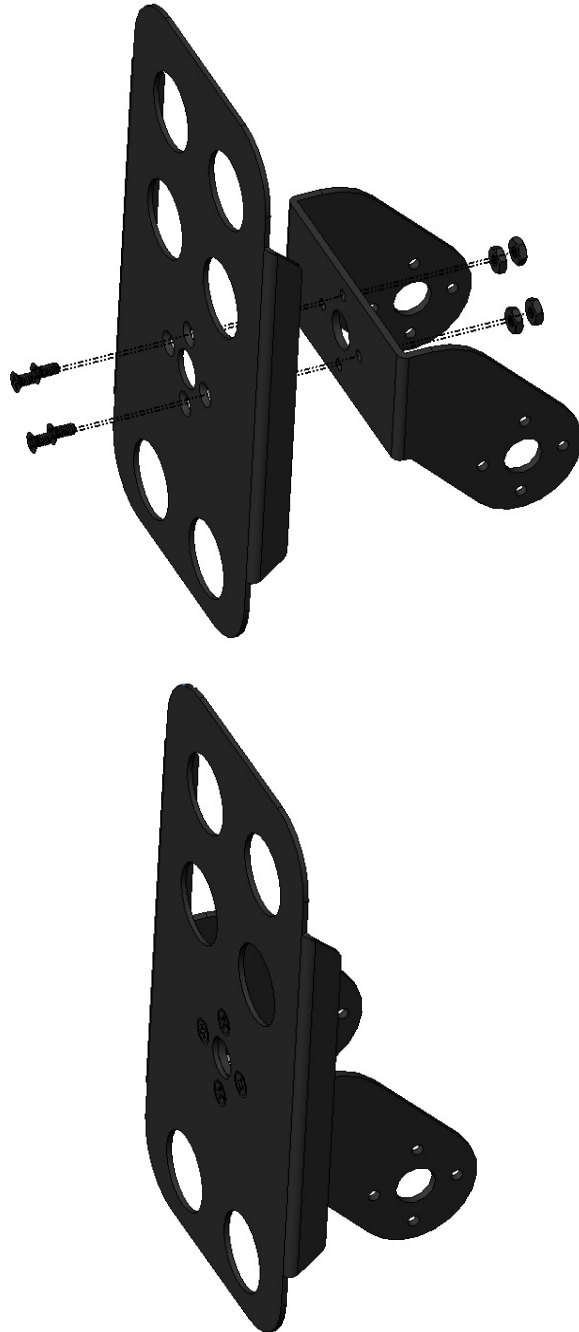

## STEP 7

Connect the tilt bracket to the servo & ball bearing and secure in place with two 2-56 self-tapping screws. You will need to flex the bracket slightly in order to fit it over the servo's horn. Note that the servo horn orientation is very important and should be horizontal (90 degrees is considering servo travel to be 0 to 180 degrees) before securing in place.

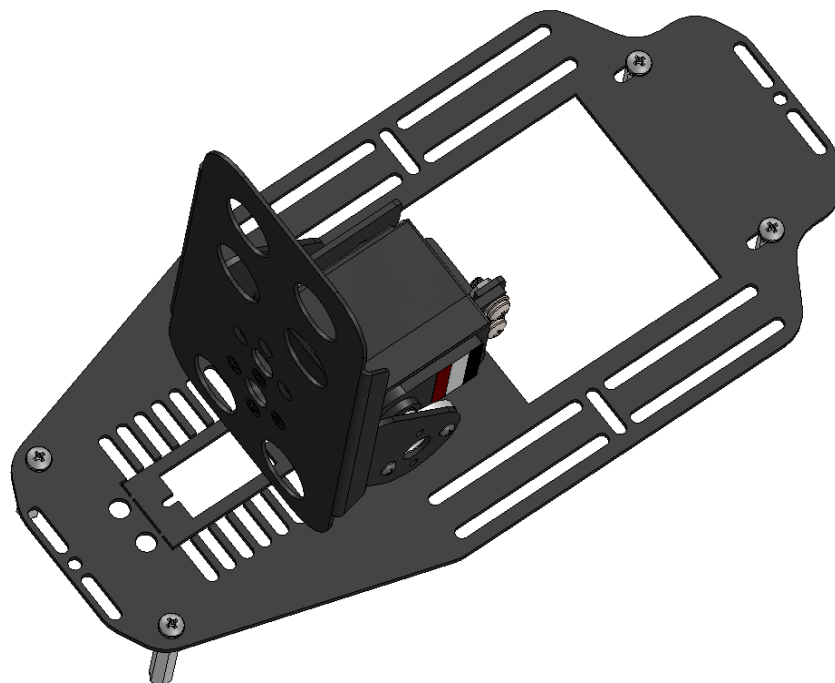
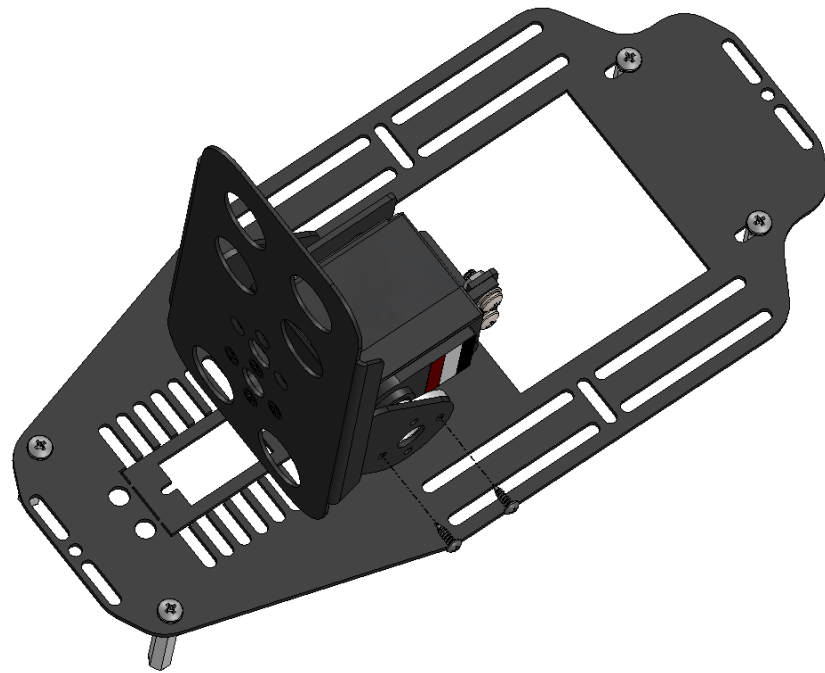



## STEP 8

Stick the anti-slip smart phone pad to the ARF-01 bracket. This pad can be run under warm water if it becomes less sticky.

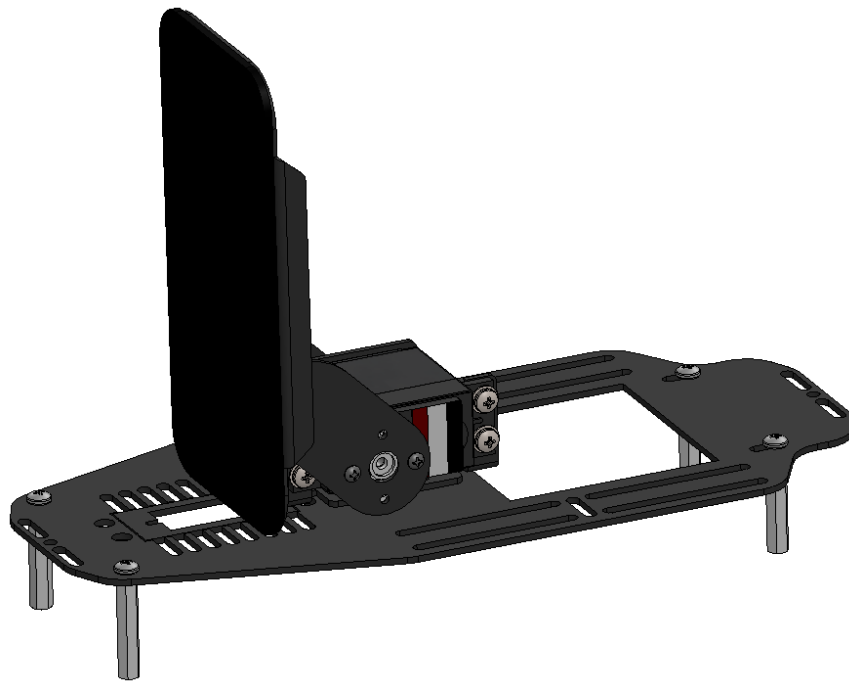
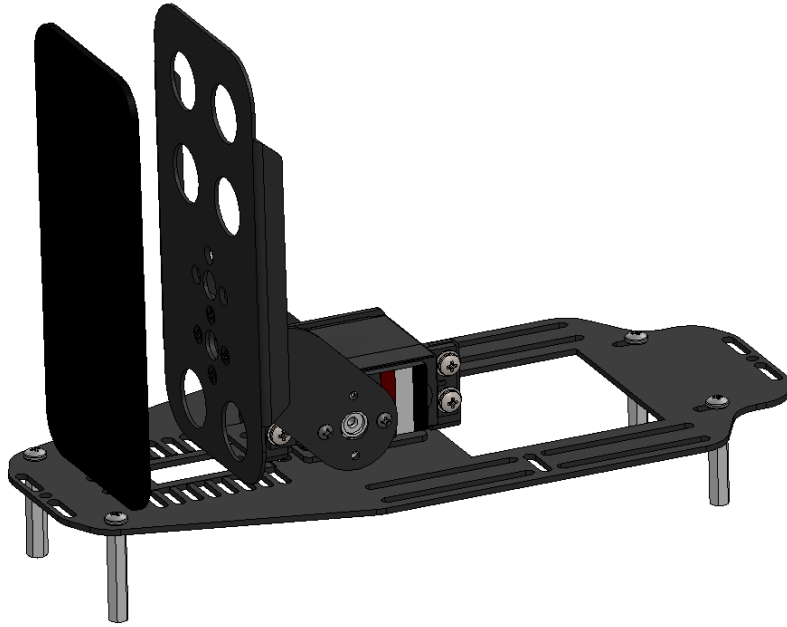

## STEP 9

You can now secure the setup to the DFRobotShop Rover using the 3mm Hex Standoffs. If the screws holding the motor in place are top down, they will need to be reversed so the thread is facing upward.

## STEP 10

Install the IO shield to the DFRobotShop Rover PCB and connect the servo's cable to one of the digital IO pins, ensuring the yellow connection is to the 'D' pin and the black connection is to the GND pin. You can move the servo using the Arduino's built-in servo library.

**Note: The servo should only be positioned so that the bracket does not contact the expansion plate. Forcing the servo to move to a position which is blocked will cause the servo to heat up and fail.**