



# Stereo IR 170 Camera Module Evaluation Kit



The Ultraleap Stereo IR 170 is a next-generation optical hand tracking module that captures the movement of users' hands and fingers so they can interact naturally with digital content. It is designed to be integrated into enterprise-grade hardware solutions, displays, installations, and virtual/augmented reality headsets for AR/VR/XR prototyping, research, and development.

The Stereo IR 170 Evaluation kit consists of the Ultraleap Stereo IR 170 camera module in a plastic housing with USB header, allowing for easy plug-and-play evaluation.

## The world's most powerful hand tracking hardware

The Ultraleap Stereo IR 170 camera module uses the same core software as its predecessor, the Leap Motion Controller. Both can discern 27 distinct hand elements, including bones and joints, and track them even when they are obscured by other parts of the hand.

Ultraleap Stereo IR 170 features a wider field of view, a longer tracking range, lower power consumption, and smaller form factor. It's capable of tracking hands within a 3D interactive zone that extends from 10cm (4") to 75cm (29.5") or more, extending from the device in a 170x170° typical field of view (160x160° minimum).

## Example applications

- Touchless public interfaces (interactive kiosks, digital out-of-home, elevators)
- Entertainment (location-based VR/AR experiences, arcades, amusement parks)
- Healthcare (stroke rehabilitation, training, mirror, medical imaging, lazy eye treatment)
- Therapy and education (anatomic visualizations, hands-on learning)
- Personnel training (flight simulators, complex computer systems)
- Industrial design and engineering (automotive, assembly lines, facilities management)
- Robotics (telepresence, robotic controls, AI-assisted teaching)
- Remote collaboration

## Easy to integrate and use

The Ultraleap Stereo IR 170 is designed for robust integration into consumer and enterprise-grade products, and can be retro-fitted to existing concepts or hardware. Plugins for Unity and Unreal enable developers working with two leading 3D development platforms to incorporate hand tracking into their established workflow.

## Specifications

Power supply:	5V DC via USB connector (minimum 0.5A).
Data connection:	Micro USB Type-B (2.0 or 3.0) when in plastic housing. When integrated, PCB module can be wired directly.
Interaction zone:	Depth of between 10 cm (4") to 75cm (29.5") preferred, up to 1 m (39") maximum; 170×170° typical field of view (160×160° minimum). Tracking works in a range of environmental conditions.
Cameras:	Stereo IR operating at 90fps
Operating wavelength:	850nm. Stereo IR 170 provides its own illumination via two IR LEDs spaced on either side of the cameras.
Ambient operating temperature:	0° to 40°C (32° to 104° F) <i>N.B. Out of case operating temperature range is slightly wider, 0° to 50°C (32° to 122° F).</i>
Minimum system requirements:	Windows® 7+; AMD Phenom™ II or Intel® Core™ i3/i5/i7 processor; 2 GB RAM; USB 2.0 port. VR headsets may come with their own system requirements. <b>Note: The Stereo IR 170 Evaluation Kit is currently Windows compatible only</b>
Software:	Downloadable from <a href="https://www.developer.ultraleap.com">https://www.developer.ultraleap.com</a>

Ultraleap reserves the right to update or modify this specification without notice.

## Intended use

The Stereo IR 170 Evaluation Kit is intended for exploration and development purposes only and is not suitable for incorporation into a product for sale or distribution. For the purpose of the Ultraleap and Leap Motion SDK agreement, the Stereo IR 170 does not constitute a "Leap Motion-authorized embedded optical module".

This kit has been designed for the purpose of enabling the evaluation of Ultraleap hand tracking by professionals at research, design, or development facilities. We recommend to download the latest version of the SDK to optimise the performance of your device. This version of hardware is not tested or certified compliant to CE requirements or equivalent international standards. To protect the evaluation kit please ensure it is always handled with care and is stored appropriately with lens caps attached when not in use. Should the lenses require cleaning, we recommend gentle cleaning using >99% isopropyl alcohol (IPA) and a soft lint free cloth.

For intended performance, it is important that your Stereo IR 170 Evaluation Kit remains flat. Minimise flexing while mounting the device. Use a stiff, flat, mounting surface or for curved surfaces an alternative solution that provides minimal flexing.

**CAUTION!** Removing the PCB from the plastic housing will invalidate your warranty. In particular, the USB header (the connection from the USB port to the PCB) is rated for 10 connections only. Removing the PCB from the plastic housing multiple times may cause the USB connection to stop working. If the PCB is outside the plastic housing, it is vulnerable to electrostatic discharge and calibration may also be affected, negatively impacting tracking performance. If you wish to remove the PCB from the plastic housing for evaluation purposes please contact Ultraleap for support.

## Evaluation use only

The Stereo IR 170 Evaluation Kit is provided for technical evaluation purposes only. Commercial or enterprise use is subject to license agreement. Resale without agreement from Ultraleap is prohibited. Get in touch with us at [www.ultraleap.com/contact](http://www.ultraleap.com/contact).

## Ultraleap Stereo IR 170 camera module

All dimensions in mm

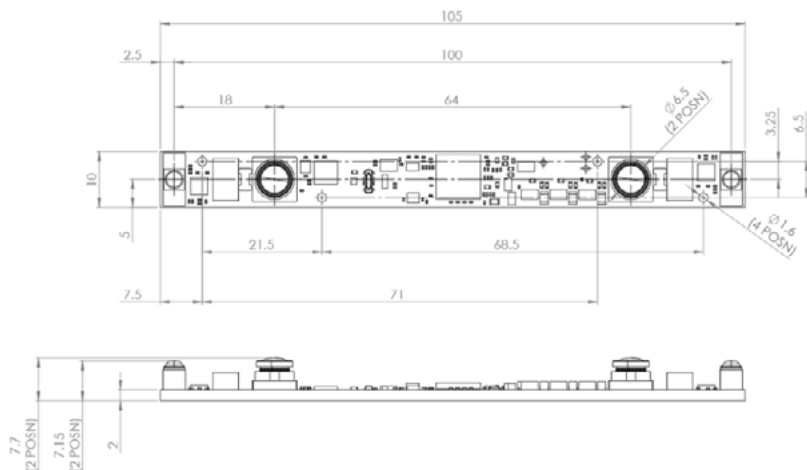

Weight: 10g

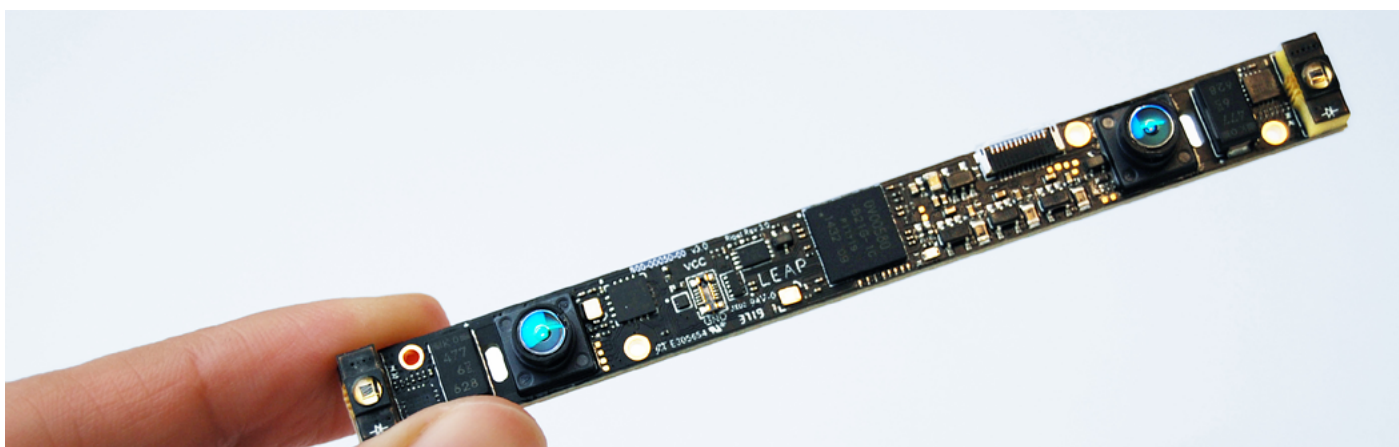

## Ultraleap Stereo IR 170 Evaluation Kit

All dimensions in mm (Stereo IR 170 camera module in plastic housing)

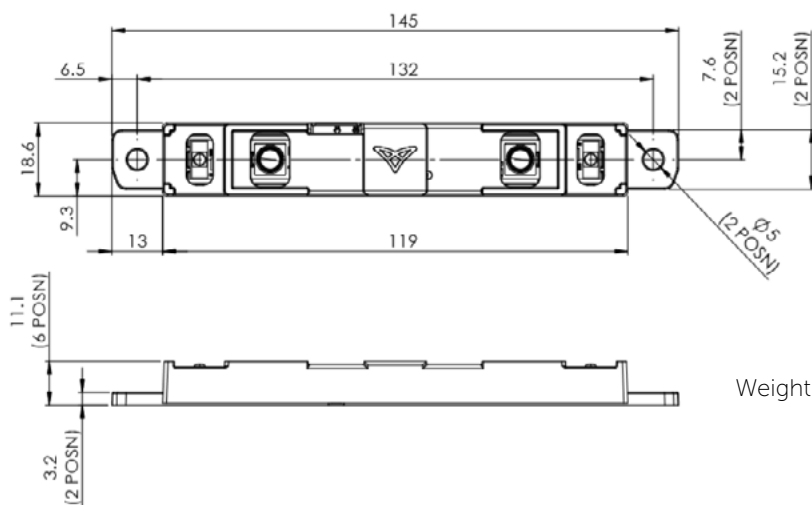

Weight: 22g

CAD files for an Evaluation Kit mount are also available from [www.developer.ultraleap.com](http://www.developer.ultraleap.com). These can be used when prototyping, particularly in instances where the Evaluation Kit will regularly be removed and replaced.