



INDUSTRIAL SHIELDS

USER GUIDE

PLC Arduino ARDBOX 20 I/Os Relay HF



Cat. Nº: ABOX-104-001-71



INDUSTRIAL SHIELDS



INDUSTRIAL SHIELDS

PLC Arduino ARDBOX 20 I/Os Relay HF User Guide

Revised March 2018

This user guide is for version PLC Arduino ARDBOX 20 I/Os Relay HF, with Reference name Ref.IS.AB20REL-HF only. For older versions refer to user guide with Cat. No. ABOX-004-001-70



Preface

This User Guide is been implemented by Boot & Work, S.L. working under the name Industrial Shields.

Purpose of the manual

The information contained in this manual can be used as a reference to operating, to functions, and to the technical data of the signal modules, power supply modules and interface modules.

Intended Audience

This User Guide is intended for the following audience:

- Persons in charge of introducing automation devices.
- Persons who design automation systems.
- Persons who install or connect automation devices.
- Persons who manage working automation installation.



Warnings:

- Unused pins should not be connected. Ignoring the directive may damage the controller.
- Improper use of this product may severely damage the controller.
- Refer to the controller's User Guide regarding wiring considerations.
- Before using this product, it is the responsibility of the user to read the product's User Guide and all accompanying documentation.



Application Considerations and Warranty

Read and Understand this Manual

Please read and understand this manual before using the product. Please consult your comments or questions to Industrial Shields before using the product.

Application Consideration

THE PRODUCTS CONTAINED IN THIS DOCUMENT ARE NOT SAFETY RATED. THEY SHOULD NOT BE RELIED UPON AS A SAFETY COMPONENT OR PROTECTIVE DEVICE FOR ENSURING SAFETY OF PERSONS, AS THEY ARE NOT RATED OR DESIGNED FOR SUCH PURPOSES.

Please know and observe all prohibitions of use applicable to the products.

FOR AN APPLICATION INVOLVING SERIOUS RISK TO LIFE OR PROPERTY WITHOUT ENSURING THAT THE SYSTEM AS A WHOLE HAS BEEN DESIGNED TO ADDRESS THE RISKS, NEVER USE THE INDUSTRIAL SHIELDS PRODUCTS.

NEVER USE THE INDUSTRIAL SHIELDS PRODUCTS BEFORE THEY ARE PROPERLY RATED AND INSTALLED FOR THE INTENDED USE WITHIN THE OVERALL EQUIPMENT OR SYSTEM.

Industrial Shields shall not be responsible for conformity with any codes, regulations or standards that apply to the combination of products in the customer's application or use of the product.

The following are some examples of applications for which particular attention must be given. This is not intended to be an exhaustive list of all possible uses of the products, nor is it intended to imply that the uses may be suitable for the products:

- Systems, machines, and equipment that could present a risk to life or property.
- Nuclear energy control systems, combustion systems, railroad systems, aviation systems, medical equipment, amusement machine, vehicles, safety equipment, and installation subject to separate industry or government regulations.
- Outdoor use, uses involving potential chemical contamination or electrical interference, or conditions or uses not described in this document.

At the customer's request, INDUSTRIAL SHIELDS will provide applicable third party certification documents identifying ratings and limitations of use that apply to the products. This information by itself is not sufficient for a complete determination of the suitability of the products in combination with the system, machine, end product, or other application or use.



Disclaimers

Weights and Dimensions

Dimensions and weights are nominal and they are not used for manufacturing purposes, even when tolerances are shown.

Performance Data

Performance data given in this manual is provided as a guide for the user in determining suitability and does not constitute a warranty. It may represent the result of INDUSTRIAL SHIELDS's test conditions, and the users most correlate it to actual application requirements. Actual performance is subject to the INDUSTRIAL SHIELDS Warranty and Limitations of Liability.

Change in Specifications

Product specifications and accessories may be changed at any time based on improvements and other reasons.

It is our practice to change model numbers when features are changed, or published ratings or when significant construction changes are made. However, some specifications of the products may be changed without any notice. When in doubt, special numbers may be assigned to fix or establish key specifications for your application on your request. Please consult with your INDUSTRIAL SHIELDS representative at any time to confirm actual specifications of purchased products.

Errors and Omissions

The information in this document has been carefully checked and is believed to be accurate; however, no responsibility is assumed for clerical, typographical, or proofreading errors, or omissions.



Warranty and Limitations of Liability

Warranty

Industrial Shields's exclusive warranty is that the products are free from defects in materials and workmanship for a period of one year (or other period if specified) from date of sale by Industrial Shields.

INDUSTRIAL SHIELDS MAKES NO REPRESENTATION OR WARRANTY, EXPRESS OR IMPLIED, REGARDING MERCHANTABILITY, NON-INFRINGEMENT, OR FITNESS FOR PARTICULAR PURPOSE OF THE PRODUCTS. ANY BUYER OR USER ACKNOWLEDGES THAT THE BUYER OR USER ALONE HAS DETERMINED THAT THE PRODUCTS WILL SUITABLY MEET THE REQUIREMENTS OF THEIR INTENDED USE. INDUSTRIAL SHIELDS DISCLAIMS ALL OTHER WARRANTIES, EXPRESS OR IMPLIED

Limitations of Liability

INDUSTRIAL SHIELDS SHALL NOT BE RESPONSIBLE FOR SPECIAL, INDIRECT, OR CONSEQUENTIAL DAMAGES, LOSS OF PROFITS OR COMERCIAL LOSS IN ANY WAY CONNECTED WITH THE PRODUCTS, WHETHER SUCH CLAIM IS BASED ON CONTRACT, WARRANY, NEGLIGENCE, OR STRICT LIABILITY.

If no event shall the responsibility of INDUSTRIAL SHIELDS for any act exceed the individual price of the product on which liability is asserted.

IN NO EVENT SHALL INDUSTRIAL SHIELDS BE RESPONSIBLE FOR WARRANTY, REPAIR OR OTHER CLAIMS REGARDING THE PRODUCTS UNLESS INDUSTRIAL SHIELDS'S ANALYSIS CONFIRMS THAT THE PRODUCTS WERE PROPERLY HANDLED, STORED, INSTALLED, AND MAINTAINED AND NOT SUBJECT TO CONTAMINATION, ABUSE, MISUSE, OR INAPPROPRIATE MODIFICATION OR REPAIR.



Table of Contents

1	ARDBOX.....	9
2	Precautions.....	10
3.1.	Arduino Board	10
3.2.	Intended Audience	10
3.3.	General Precautions.....	10
3	Technical Specifications	11
3.1	General Specifications:.....	11
3.2	Performance Specification:	11
4	Software interface.....	12
5	How to connect PLC Arduino to PC.....	15
6	How to connect PLC to power supply	16
	Din RAIL Power Supply, ac-dc, 30W, 1 Output 1.3A at 24Vdc	17
7	Ardbox Relay HF I/O Pinout:.....	17
7.1	Zone Connections.....	17
8	Switch configuration	19
8.1	General Switches Configurations	19
8.2	RS- 485 Switch configuration	20
8.3	RS- 232 Switch configuration	21
8.4	I2C Switch configuration	21
9	Jumper configuration	22
9.1	General jumper configuration.....	22
10	Hardware Serial RS-232 & RS-485 Configuration.....	23
10.1	Hardware Serial RS-232.....	23
10.2	Hardware Serial RS-485.....	24
11	I/O technical details	25
12	Connector details	28
13	ARDBOX Family Dimensions:.....	29
14	DIN rail mounting:	29



1 ARDBOX

A compact PLC based in Open Source Hardware technology. With different Input/Outputs Units.



INDUSTRIAL SHIELDS



Supply Voltage

24 Vcc**Compact**

DIN rail mounting

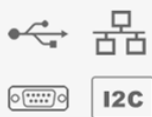

COMPACT PLC ARDUINO ARDBOX 20 I/Os RELAY HF		
Alimentation Voltage	12 to 24Vdc	Fuse protection (2.5A) Polarity protection
Max. current consumption	1,5A	
Size	100x45x115	
Clock Speed	16MHz	
Flash Memory	32KB of which 4KB are used by bootloader	
SRAM	2.5KB	
EEPROM	1KB	
Communications	I2C -- USB -- RS232 -- RS485 -- SPI	
TOTAL Input points	10	
TOTAL Output points	10	
INPUTS	Digital range: 5 to 24 Vdc (3.8 to 25.4 Vdc) Analog range: 0 to 10 Vdc	
Digital	10	5 to 24Vdc I min: 3/6 mA Separated PCB ground
Analog 10 bits	6 of 10 Digital input	0 to 10V Input Impedance: 39K Separated PCB ground
* Interrupt HS	4 of 10 Digital input	5 to 24Vdc

Cat. Nº: ABOX-104-001-71

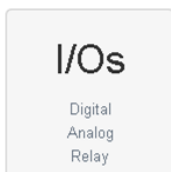

		I min: 5/10 mA Separated PCB ground
OUTPUTS	Digital Isolated range: 5 to 24 Vdc (4.6 to 25.4 Vdc) Analog range: 0 to 10 Vdc	
Relay	8	I _{max} : 5A (See Relay Specification in i/o technical details)
Analog 8 bits	2	0 to 10 Vdc I max: 40 mA Separated PCB ground
Expandability	I2C* – RS232* - RS485* – SPI – USB	
Reference	IS.AB20REL.HF	
* By using this type of signal you can no longer use Digital signal You must read product Datasheet.		

2 Precautions

3.1. Arduino Board

All Ardbox family products use Arduino LEONARDO Board.

3.2. Intended Audience

This manual is intended for technicians, which must have knowledge of electrical systems.

3.3. General Precautions

The user must operate the product according to the performance specifications described in the operation manuals.

Before using the product under conditions, which are not described in the manual or applying the product to nuclear control systems, railroad systems, aviation systems, vehicles, combustion systems, medical equipment, amusement machines, safety equipment and other systems, machines, and equipment that may have a serious influence on lives and property if used improperly, consult your INDUSTRIAL SHIELDS representative.

Make sure that the rating and performance characteristics of the product are sufficient for the systems, machines, and equipment, and be sure to provide the systems, machines, and equipment with double safety mechanisms.

This manual provides information for programming and operating the Unit. Be sure to read this manual before attempting to use the Unit keep this manual close at hand for reference during operation.



3 Technical Specifications

3.1 General Specifications:

Power supply voltage	DC power supply	12 to 24Vdc
Operating voltage range	DC power supply	11.4 to 25.4Vdc
Power consumption	DC power supply	30VAC max.
External power supply	Power supply voltage	12 to 24Vdc
	Power supply output capacity	1.3A
Insulation resistance	20M Ω min.at 500Vdc between the AC terminals and the protective earth terminal.	
Dielectric strength	2.300 VAC at 50 to 60 HZ for one minute with a leakage current of 10mA max. Between all the external AC terminals and the protective earth terminal.	
Shock resistance	80m/s ² in the X, Y and Z direction 2 times each.	
Ambient temperature (operating)	0° to 45°C	
Ambient humidity (operating)	10% to 90% (no condensation)	
Ambient environment (operating)	With no corrosive gas	
Ambient temperature (storage)	-20° to 60°C	
Power supply holding time	2ms min.	
Weight	340g max.	

3.2 Performance Specification:

Arduino Board	ARDUINO LEONARDO
Control method	Stored program method
I/O control method	Combination of the cyclic scan and immediate refresh processing methods.
Programming language	Arduino IDE. Based on wiring (Wiring is an Open Source electronics platform composed of a programming language. "similar to the C". http://arduino.cc/en/Tutorial/HomePage)
Microcontroller	ATmega32u4



Flash Memory	32kb of which 4 kb are used by bootloader
Program capacity (SRAM)	2.5kb
EEPROM	1kb
Clock Speed	16MHz

4 Software interface

Industrial Shields PLC are programmed using Arduino IDE, which is a software based on the C language. They can also be programmed using directly C but it is much easier working with Arduino IDE as it provides lots of libraries that helps in the programming.

Furthermore Industrial Shields provides boards for programming the PLCs much easier. Basically it is no needed to define the pins and if that pins are inputs or outputs. Everything is set up automatically if using the boards.

In order to install Industrial Shields boards, these are the steps that must be followed.

Requirements:

Arduino IDE 1.8.0 or above (better to have always the latest version).

Steps:

1. Open Arduino IDE and go to: "File -> Preferences" located in the top left corner.

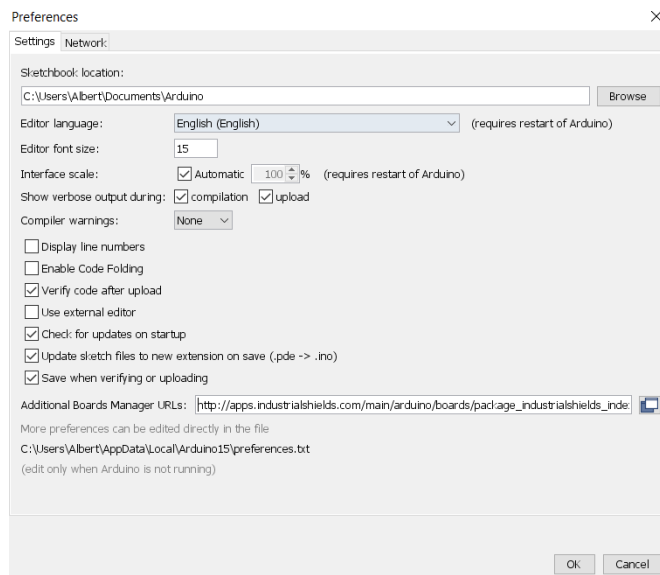

2. In Additional Boards URLs write the following:

http://apps.industrialshields.com/main/arduino/boards/package_industrialshields_index.json



3. Press OK to save the changes.
4. Go to: Tools -> Board: ... -> Boards Manager

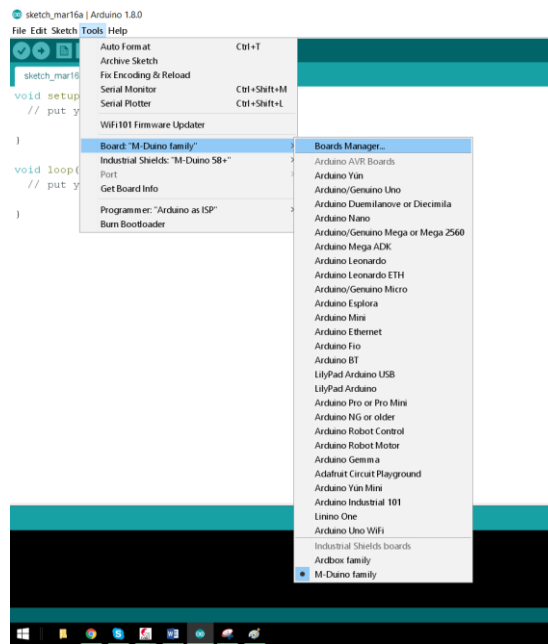

5. Search for industrialshields on the searcher.

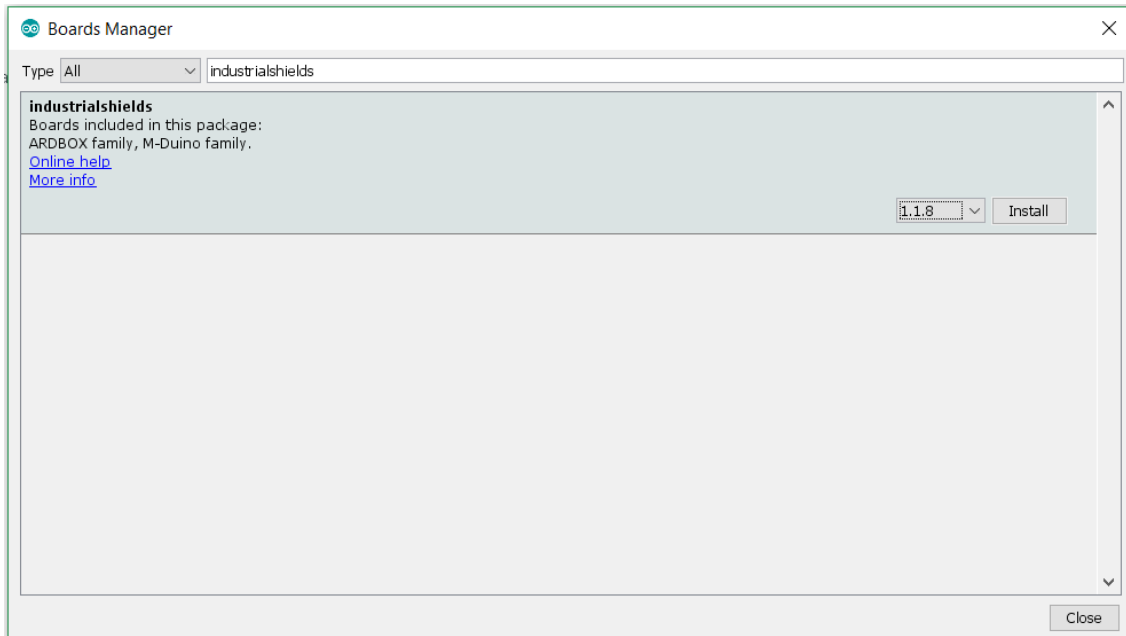

6. Click install (selecting the latest version).

Following this steps you will be able to use now the Industrial Shields Boards:

Cat. N°: ABOX-104-001-71

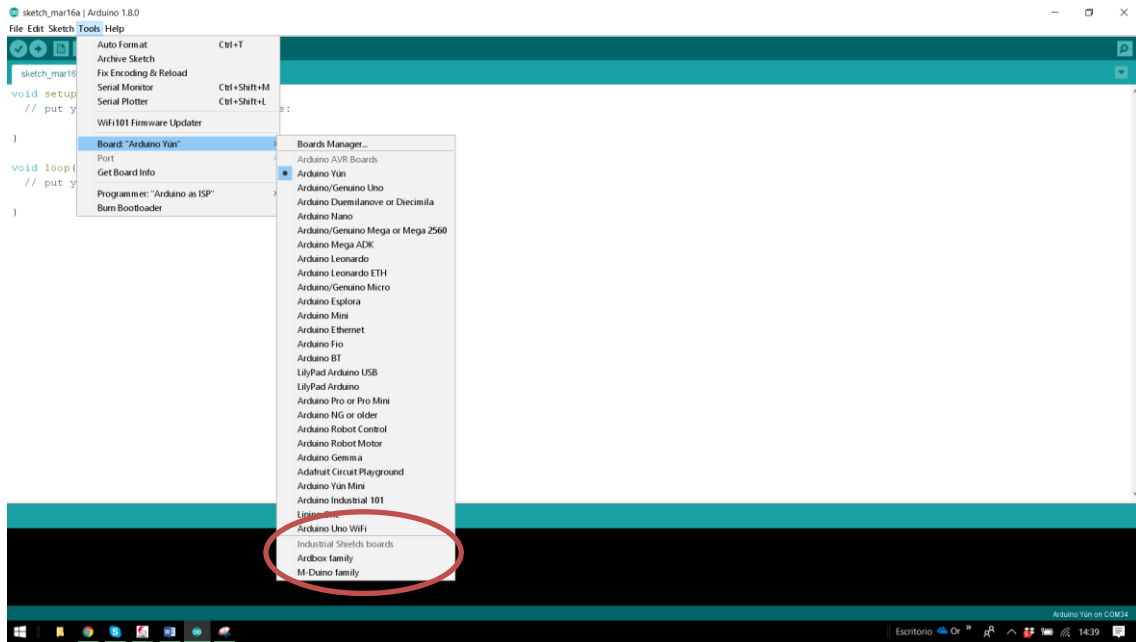

Once it is selected the Ardbox Family or M-Duino family an extra option will appear on Tools:

There, it can be selected the exact model for every family.

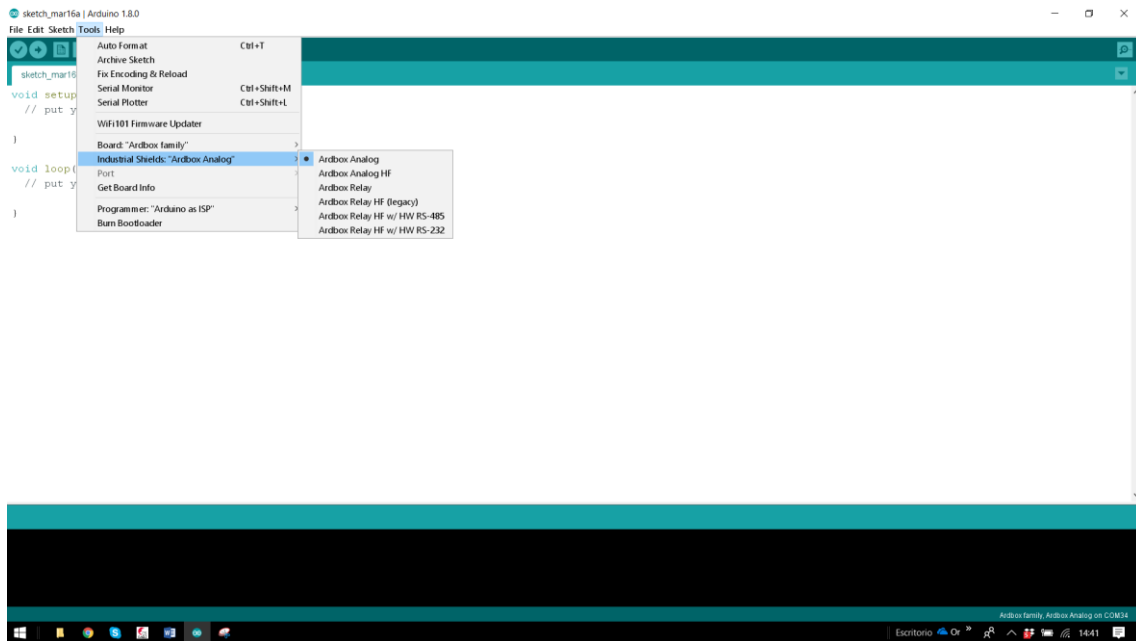

Also there are some examples of programming in File -> Examples -> Ardbox Family.

Furthermore there are some extra libraries that can be found in Industrial Shields github.

<https://github.com/IndustrialShields/>



5 How to connect PLC Arduino to PC

- Connect USB port from PLC to PC.

NOTE:

Ardbox Family use micro USB cable.



- Open Arduino IDE interface:
- Select Industrial Shields boards -> Ardbox Family
- Select the correct Ardbox Relay Board.

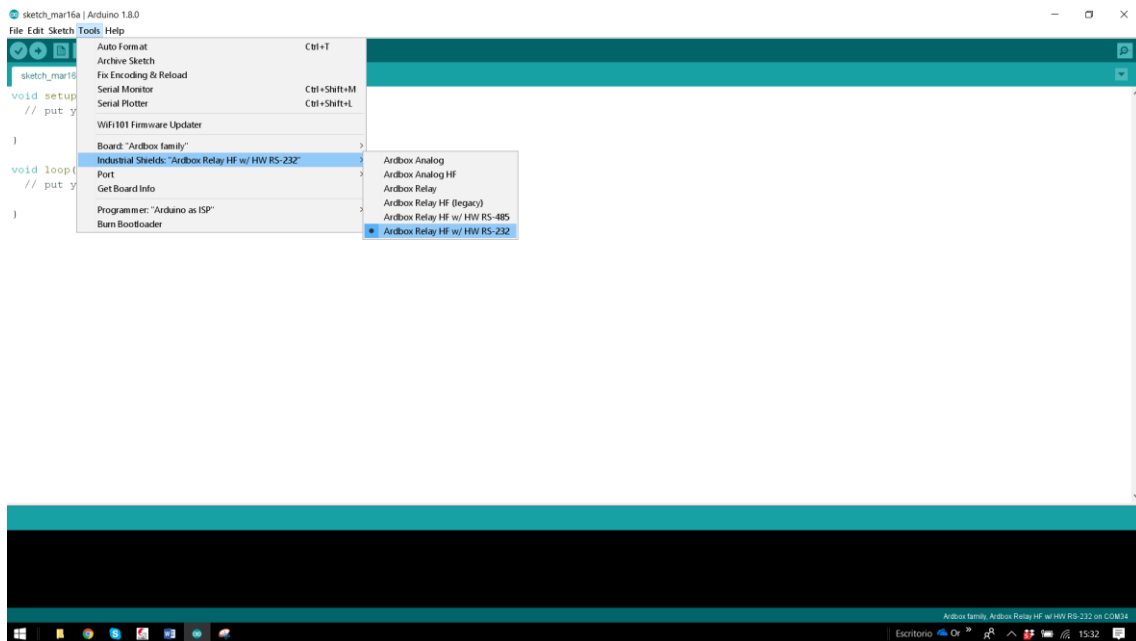

If it is used the latest version of Industrial Shields boards it will appear 4 different Ardbox Relay boards:

The ones that have to be used for the 104-001-71 Ardbox Relay HF are the following ones:

- Ardbox Relay HF w/ HW RS-485
- Ardbox Relay HF w/ HW RS-232

* HW is the abbreviation of Hardware, so depending on the Hardware Serial it will be used, it is needed to select one or the other. See section 11 to configure the equipment to work with RS-232 Hardware Serial or RS-485 Hardware Serial.

If it is not used the RS-232 & RS-485 it is needed to select the board Ardbox Relay HF w/ HW RS-485. See section 9-10 to enable the features that are disabled if using RS-485 protocol that will get enabled as there is no RS protocol.



- Select correct port.

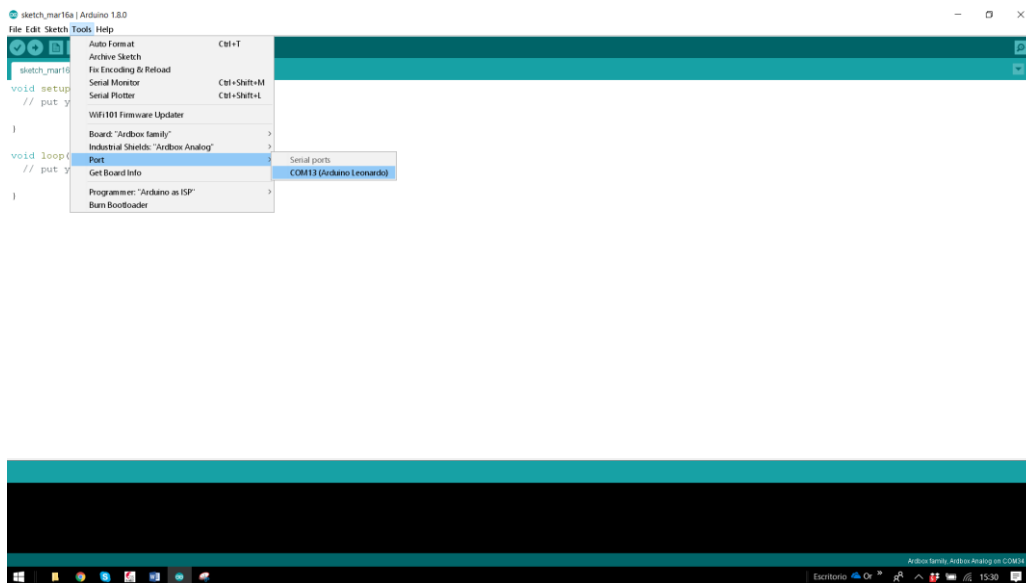

Now everything is set up to upload a sketch to Ardbox Relay HF

6 How to connect PLC to power supply

- Ardbox Family PLCs are 12 to 24Vdc supplied. **IMPORTANT: The polarity IS NOT REVERSAL!**
- Make sure that the live and GND connector of the power supply match the PLC.
- Make sure that the power supply mains output is not higher than 24Vdc.

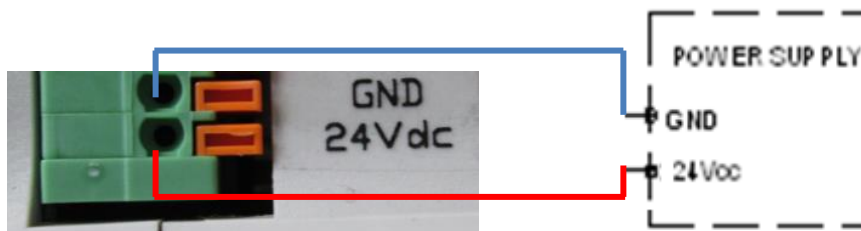



- Suggested power suppliers



* Not recommended for industrial applications. The Jack connector needs to be removed and use the live and GND connectors.



Din RAIL Power Supply, ac-dc, 30W, 1 Output 1.3A at 24Vdc

7 Ardbox Relay HF I/O Pinout:

7.1 Zone Connections

Base (common unit)			
LEFT ZONE			
Ardbox Connector	Arduino Pin RS-232 HS*	Arduino Pin RS-232 SS*	Function
MISO	14	14	SPI-MISO
MOSI	16	16	SPI-MOSI
SCK	15	15	SPI-CLOCK
RESET	-	-	SPI-RESET
5VdC	-	-	5V Output
GND	-	-	GND
RX-RS-232 ^{1,2}	1	4	Serial/RS232
TX-RS-232 ^{1,2}	0	8	Serial/RS232
SDA-PIN2 ¹	2	2	I2C/SPI SS
SCL-PIN3 ¹	3	3	I2C/SPI SS
R1	10	10	Relay 1 Out
R2	9	9	Relay 2 Out
R3	6	6	Relay 3 Out
GND	-	-	GND
24V	-	-	-

HS*: Hardware Serial

SS*: Software Serial

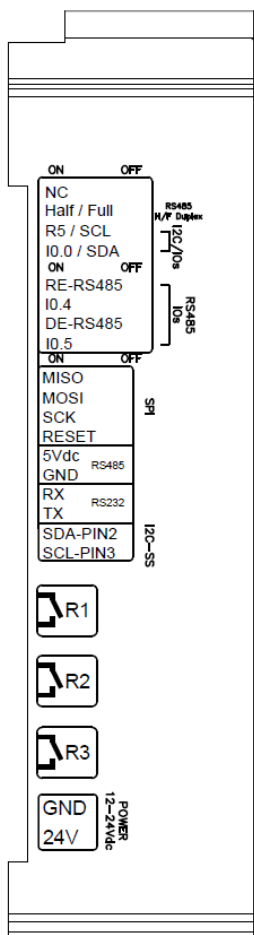

LEFT ZONE

Switch config*

(see section 9 for Communications configuration. Enabling Communications disables some I/Os)

Communications pinout

Relay Outputs

Power supply connectors (24Vdc – Gnd)

¹ See section 9 to enable these connections

² See section 10 to enable these connections



Base (common unit)			
RIGHT ZONE			
Ardbox Connector	Arduino Pin RS-485 HD*	Arduino Pin RS-485 FD*	Function
B-	-	-	RS485
A+	-	-	RS485
Z-/A0.1	11	-	RS485/Analog Output
Y+/A0.0	13	-	RS485/Analog Output
R4	5	5	Relay 4 Out
R5	3	3	Relay 5 Out
IO.9	A5	A5	Analog/Digital Input
IO.8	A4	A4	Analog/Digital Input
IO.7	A3	A3	Analog/Digital Input
IO.6	A2	A2	Analog/Digital Input
IO.5 ¹	A1	A1	Analog/Digital Input
IO.4 ¹	A0	A0	Analog/Digital Input
IO.3 ²	8	8	Digital Input/ Interrupt
IO.2 ²	4	4	Digital Input/ Interrupt
IO.1	12	12	Digital Input/ Interrupt
IO.0 ¹	2	2	Digital Input/ Interrupt
R6	7	7	Relay 6 Out
R7 ¹	0	0	Relay 7 Out
R8 ¹	1	1	Relay 8 Out

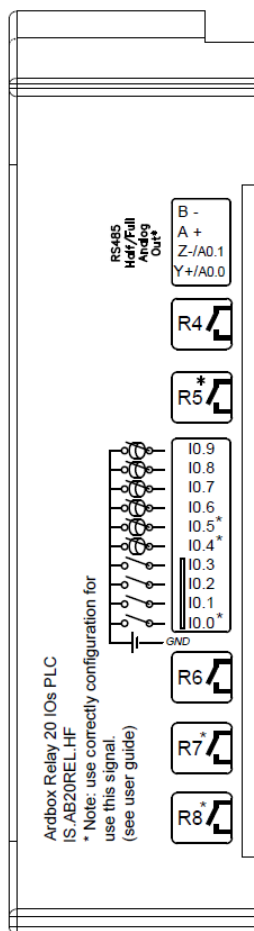

RIGHT ZONE

RS-485 pinout
Analog Outputs Pinout

Relay Outputs

Inputs pinout

Relay Outputs

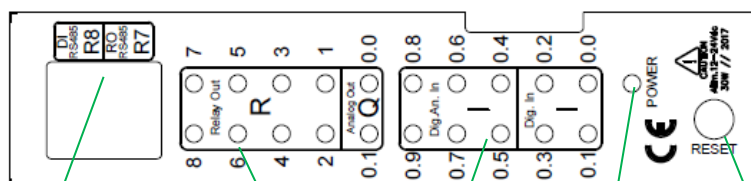

Config switch *
(see section 9 for communications configuration)

Input / Output LED

Power LED

Arduino Reset button



8 Switch configuration

8.1 General Switches Configurations

LEFT ZONE.

Communications and inputs/outputs can not work simultaneously.

LEFT ZONE		
SWITCH	ON	OFF
NC	-	-
H/F	Half Duplex	Full Duplex
SCL/R5	R5	SCL
SDA/I0.0	I0.0	SDA
RE-RS485	RE-RS485	I0.4
I0.4	I0.4	RE-RS485
DE-RS485	DE-RS485	I0.5
I0.5	I0.5	DE-RS485

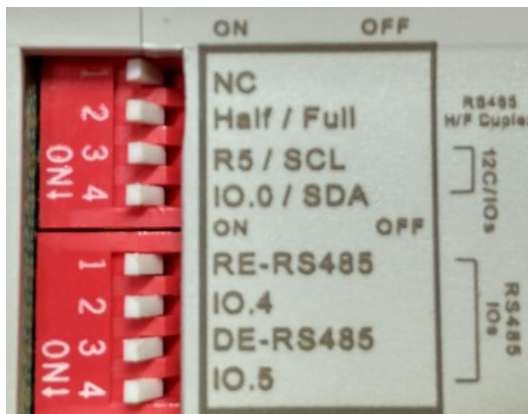

1. NC – Not Connected
 2. H/F – Choosing between Half/Full Duplex for the RS485 communication. In order to use Full Duplex, it has to be considered the TOP ZONE and the JUMPER ZONE(*see section 10).
 3. SCL/R5 – Choosing between SCL (I2C) and R5. If the switch is ON, the R5 will be enabled and the SCL will be disabled. If the switch is OFF, SCL will be now enabled and R5 disabled.
 4. SDA/I0.0 - Choosing between SDA (I2C) and I0.0. If the switch is ON, the I0.0 will be enabled and the SDA will be disabled. If the switch is OFF, SDA will be now enabled and R5 disabled.
-
1. RE-RS485 – If this switch is ON, the I0.4 switch must be set to OFF. Being in ON mode it enables RE for the RS-485.
 2. I0.4 – If this switch is ON, the RE-RS485 switch must be set to OFF. Being in ON mode it enables the input I0.4.
 3. DE-RS485 – If this switch is ON, the I0.5 switch must be set to OFF. Being in ON mode it enables DE for the RS-485.
 4. I0.5 – If this switch is ON, the DE-RS485 switch must be set to OFF. Being in ON mode it enables the input I0.5.

TOP ZONE.

TOP ZONE		
SWITCH	ON	OFF
D1 - RS-485	RS-232/485	R8
R8	R8	RS-232/485
D0 - RS-485	RS-232/485	R7
R7	R7	RS-232/485

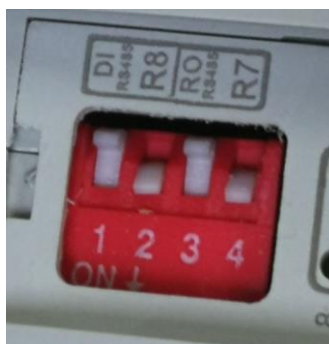

Communications and outputs can not work simultaneously.



1. D1 – RS-485: If this switch is ON, the R8 switch must be set to OFF. Being in ON mode it enables DI for the RS-485 and RS-232 Hardware Serial (see section 9 for jumper configuration)
2. R8: If this switch is ON, the DI – RS-485 switch must be set to OFF. Being in ON mode it enables the Relay 8.
3. D0 – RS-485: If this switch is ON, the R7 switch must be set to OFF. Being in ON mode it enables D0 for the RS-485 or RS-232 Hardware Serial (see section 9 for jumper configuration)
4. R7: If this switch is ON, the D0 – RS-485 switch must be set to OFF. Being in ON mode it enables the Relay 7.

8.2 RS- 485 Switch configuration

TOP ZONE	
SWITCH	MODE
DI - RS-485	ON
R8	OFF
D0 - RS-485	ON
R7	OFF

RS-485 TOP ZONE: In order to enable the RS-485 protocol the TOP ZONE must be configured as it is shown in the table.

Although the switch name only is referenced to RS-485 it is also the same for the RS-232.

Having this set up, the R7 & R8 are disabled.

LEFT ZONE	
SWITCH	MODE
NC	-
H/F	ON/OFF
SCL/R5	-
SDA/I0.0	-
RE-RS485	ON
I0.4	OFF
DE-RS485	ON
I0.5	OFF

RS-485 LEFT ZONE: The H/F can be set up as ON or OFF. If it is wished to use the RS-485 Half Duplex (A+, B-) it has to be ON. For using the RS-485 Full Duplex (A+, B-, Y+, Z-) it has to be OFF.

The switch RE-RS485 and DE-RS485 must be set in ON mode. As these pins are set to ON, the other 2 (I0.4, I0.5) must be set to OFF. Being in OFF mode they are completely disabled.

The switches marked as “ – “ don't interfere with the RS-485 communication protocol.

* To enable the RS-485 communication it is needed to configure also the jumpers, see Section 10



8.3 RS- 232 Switch configuration

TOP ZONE	
SWITCH	MODE
DI - RS-485	ON
R8	OFF
DO - RS-485	ON
R7	OFF

RS-232 TOP ZONE: In order to enable the RS-232 protocol the TOP ZONE must be configured as it is shown in the table.

Although the switch name only is referenced to RS-485 it is also the same for the RS-232.

Having this set up, the R7 & R8 are disabled.

LEFT ZONE	
SWITCH	MODE
NC	-
H/F	-
SCL/R5	-
SDA/I0.0	-
RE-RS485	OFF
I0.4	ON
DE-RS485	OFF
I0.5	ON

RS-232 LEFT ZONE: As both RS-232 & RS-485 can't work at the same time, the RE-RS485 and DE-RS485 have to be in OFF mode, so this enables the I0.4, I0.5 inputs.

** To enable the RS-232 communication it is needed to configure also the jumpers, see Section 10*

8.4 I2C Switch configuration

TOP ZONE	
SWITCH	MODE
DI - RS-485	-
R8	-
DO - RS-485	-
R7	-

LEFT ZONE	
SWITCH	MODE
NC	-
H/F	-
SCL/R5	ON
SDA/I0.0	ON
RE-RS485	-
I0.4	-
DE-RS485	-
I0.5	-

To enable I2C configuration the switches SCL/R5 & SDA/I0.0 must be set to ON. As they are in ON mode R5 & I0.0 are disabled.

The switches marked as “ - ” don't interfere with the I2C communication protocol.



9 Jumper configuration

9.1 General jumper configuration

JUMPER ZONE 1	
LEFT	RIGHT
Y+	Z-
ENABLE	ENABLE
A0.0	A0.1

This jumper zone makes the selection between using the RS-485 Full Duplex or the Analog Outputs. If it is wanted to use the RS-485 Full Duplex communication protocol the Y+ must be connected to ENABLE, and Z- also connected to ENABLE. If it is wanted to use the Analog Outputs, The A0.0 must be connected to ENABLE, and A0.1 also connected to Enable

JUMPER ZONE 2	
LEFT	RIGHT
I0.2	I0.3
D4	D8
RS-232	RS-232

This jumper zone makes the choosing between connecting the inputs I0.2, I0.3 to pins 4, 8 of the Arduino Leonardo respectively, or connect the RS-232 ports to activate the Software Serial RS-232. In order to use the inputs I0.2,I0.3 the jumper must be connected to the pins 4,8. So I0.2 must be connected with D4 and I0.3 must be connected to D8.

JUMPER ZONE 3			
UP	RS-485	D1	RS-232
DOWN	RS-485	D0	RS-232

This jumper makes the choosing between connecting MAX232 to pins 0,1 of the Arduino Leonardo or with the MAX485. In order to use the RS-232 Hardware Serial protocol both RS-232 must be connected to the D1/D0. In order to use the RS-485 Hardware Serial protocol both RS-485 must be connected to the D1/D0.

*The jumpers that are not connected to the middle jumpers MUST NOT be connected anywhere.

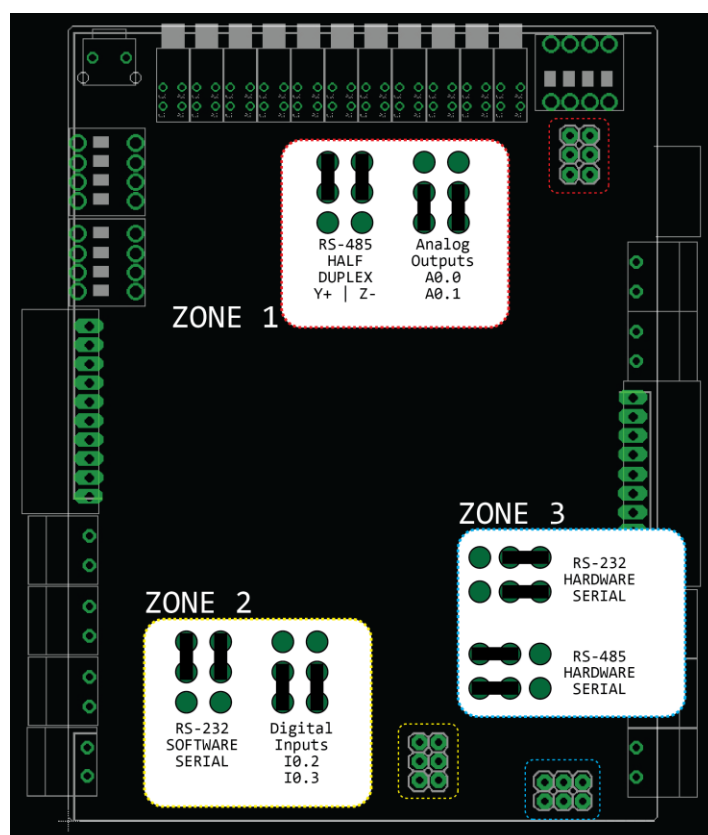



10 Hardware Serial RS-232 & RS-485 Configuration

10.1 Hardware Serial RS-232

In order to enable the Hardware Serial RS-232 the total configuration of the Ardbox Relay HF will be:

Switch configuration:

TOP ZONE	
SWITCH	MODE
DI - RS-485	ON
R8	OFF
DO - RS-485	ON
R7	OFF

LEFT ZONE	
SWITCH	MODE
NC	-
H/F	-
SCL/R5	-
SDA/I0.0	-
RE-RS485	OFF
I0.4	ON
DE-RS485	OFF
I0.5	ON

Jumper configuration:

JUMPER ZONE 1	
LEFT	RIGHT
NC	NC
ENABLE	ENABLE
A0.0	A0.1

JUMPER ZONE 2	
LEFT	RIGHT
I0.2	I0.3
D4	D8
NC	NC

JUMPER ZONE 3			
UP	NC	D1	RS-232
DOWN	NC	D0	RS-232

Having configured Ardbox Relay HF as it is shown above, these are the features that are available:

- Available communication protocols:
 - Hardware Serial RS-232.
 - I2C *If I2C is active R5 & I0.0 are disabled
 - SPI
- Inputs: All 10 inputs, from I0.0 to I0.9. If using I2C I0.0 is disabled
- Relay Outputs: From R1 to R6. If using I2C R5 is disabled. R7 and R8 are disabled from the TOP ZONE switch.
- Analog Outputs: A0.0 & A0.1



10.2 Hardware Serial RS-485

In order to enable the Hardware Serial RS-485 the total configuration of the Ardbox Relay HF will be:

Switch configuration:

TOP ZONE	
SWITCH	MODE
DI - RS-485	ON
R8	OFF
DO - RS-485	ON
R7	OFF

LEFT ZONE	
SWITCH	MODE
NC	-
H/F	ON/OFF
SCL/R5	-
SDA/I0.0	-
RE-RS485	ON
I0.4	OFF
DE-RS485	ON
I0.5	OFF

Jumper configuration:

JUMPER ZONE 1 HALF DUPLEX	
LEFT	RIGHT
Y+	Z-
ENABLE	ENABLE
A0.0	A0.1

JUMPER ZONE 2	
LEFT	RIGHT
I0.2	I0.3
D4	D8
NC	NC

JUMPER ZONE 3			
UP	NC	D1	RS-232
DOWN	NC	D0	RS-232

JUMPER ZONE 1 FULL DUPLEX	
LEFT	RIGHT
Y+	Z-
ENABLE	ENABLE
A0.0	A0.1

Having configured Ardbox Relay HF as it is shown above, these are the features that are available:

- Available communication protocols:
 - Hardware Serial RS-485.
 - I2C *If I2C is activated R5 & I0.0 are disabled
 - SPI
- Inputs: All 10 inputs except for input I0.4, I0.5 as they are disabled from the LEFT ZONE switch. If using I2C I0.0 is disabled
- Relay Outputs: From R1 to R6. If using I2C R5 is disabled. R7 and R8 are disabled from the TOP ZONE switch.
- Analog Outputs: A0.0 & A0.1 if RS-485 is working in Half Duplex. They are disabled if using RS-485 Full Duplex, see the JUMPER ZONE 1 from above.



11 I/O technical details

Relay

■ Contact Ratings

Load	High-capacity
Rated load (resistive, p.f.= 1)	5 A at 250 VAC 3 A at 30 VDC
Max. switching voltage	250 VAC, 30 VDC
Rated carry current	5A
Max. switching current	5A (AC load,) 3A (DC load)
Max. switching power	1,250 VA, 90 W

■ Characteristics

Contact resistance (see note 2)	100 mΩ max.
Operate time	10 ms max.
Release time	10 ms max.
Insulation resistance (see note 3)	1,000 MΩ min. (at 500 VDC)
Dielectric strength	4,000 VAC, 50/60 Hz for 1 min. between coil and contacts 750 VAC, 50/60 Hz for 1 min. between contacts of same polarity
Impulse withstand voltage	10,000 V (1.2 x 50 μs) between coil and contacts
Vibration resistance	Destruction: 10 to 55 Hz, 1.5-mm double amplitude Malfunction: 10 to 55 Hz, 1.5-mm double amplitude
Shock resistance	Destruction: 1,000 m/s ² (approx. 100 G) Malfunction: 100 m/s ² (approx. 10 G)
Life expectancy	Mechanical: 5,000,000 operations min. (18,000 operations/hour) Electrical: 200,000 operations minimum: High-capacity Standard 5 A at 125 VAC 3 A at 125 VAC 3 A at 30 VDC 3 A at 30 VDC 100,000 operations minimum: High-capacity 5 A at 250 VAC All electrical load ratings are resistive, with operation frequency = 1,800 operations/hour.
Minimum permissible load (reference value) (see note 4)	5 VDC, 10 mA
Ambient temperature	Operating: -40°C to 70°C (with no icing or condensation)
Ambient humidity	Operating: 5% to 85%
Weight	Approx. 4 g

Note: 1. The data shown above are initial value.

2. Measurement conditions: 5 VDC, 1 A, voltage drop method

3. Measurement conditions: Measured at the same points as the dielectric strength using a 500-VDC ohmmeter.

4. This value is for a switching frequency of 120 operations/minute. (P level: $\lambda_{50} = 0.1 \times 10^{-6}$ operations)

Standard models

Maximum Switching Capacity

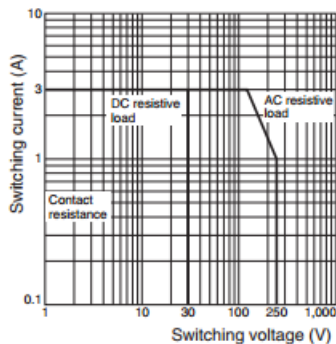

Electrical Service Life

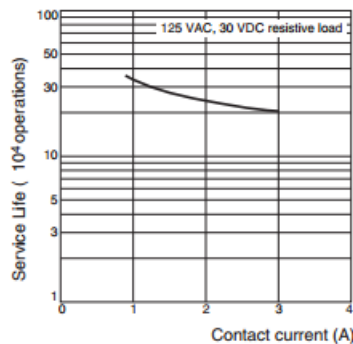



High-capacity models

Maximum Switching Capacity

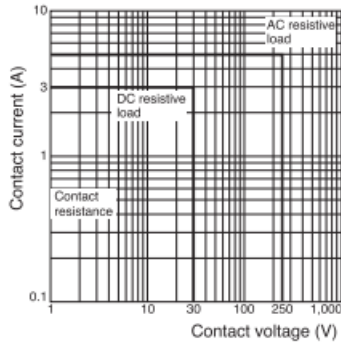

Electrical Service Life

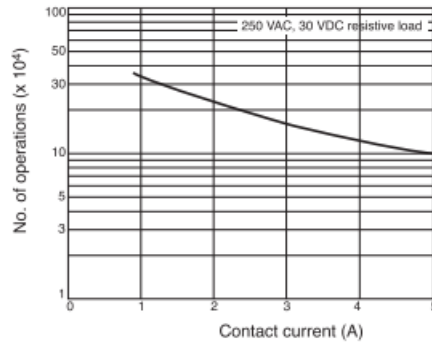

Standard models

Ambient Temperature vs. Maximum Coil Voltage

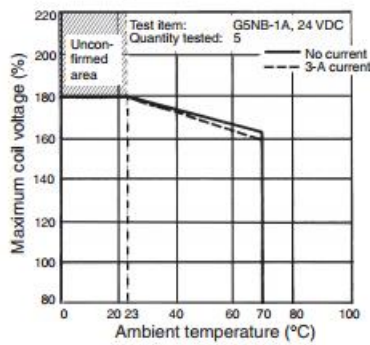

High-capacity models

Ambient Temperature vs. Maximum Coil Voltage

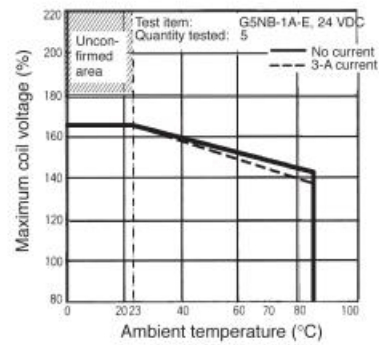

Note: The maximum coil voltage refers to the maximum value in a varying range of operating power voltage, not a continuous voltage.

Analog Out Turn-on

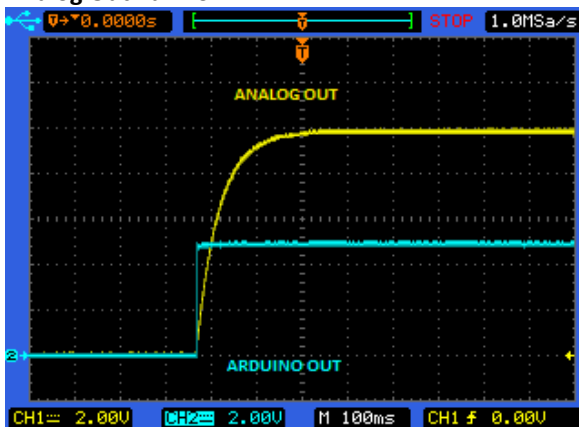



Analog Out Turn-off

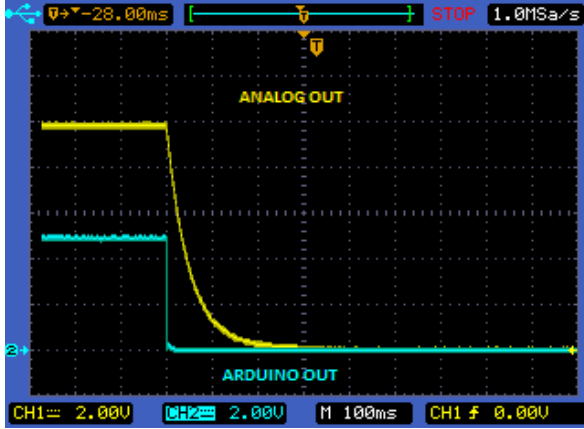

Analog/Digital Input Turn-on

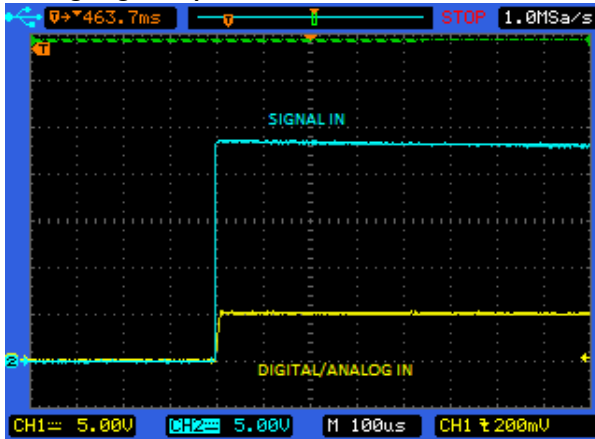

Analog/Digital Input Turn-off

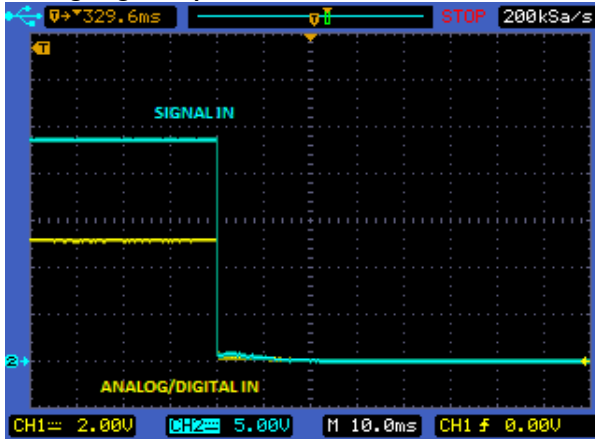



12 Connector details

The connector inside the PLCs that mounts on the PCB is MC 0,5/10-G-2,5 THT – 1963502 from Phoenix contact. [MC0,5/10-G-2,5THT](#)

For I/O and power supply there is a FK-MC 0,5/10-ST-2,5 - 1881406 connector from Phoenix contact. [FK-MC 0,5/10-ST-2,5](#)

Connection details:

Article reference	MC 0,5/10-G-2,5 THT
Height	8,1mm
Pitch	2,5mm
Dimension	22,5mm
Pin dimensions	0,8x0,8mm
Pin spacing	2,50mm



Article reference	FK-MC 0,5/10-ST-2,5
Rigid conduit section min.	0,14 mm ²
Rigid conduit section max.	0,5 mm ²
Flexible conduit section min.	0,14 mm ²
Flexible conduit section max.	0,5 mm ²
Conduit section AWG/kcmil min.	26
Conduit section AWG/kcmil max.	20

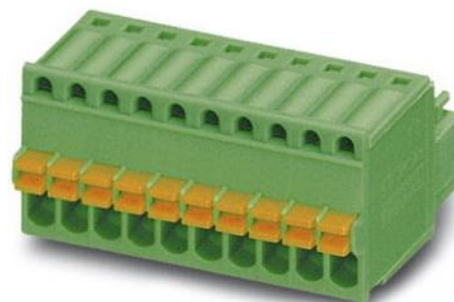



13 ARDBOX Family Dimensions:

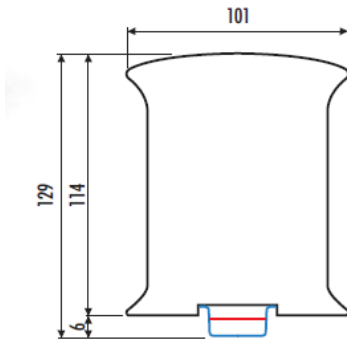

45mm width

14 DIN rail mounting:

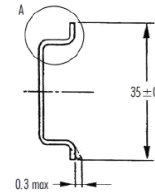
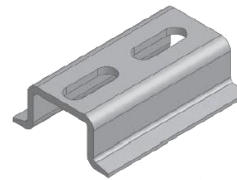

Profilato a cappello TH 35-7,5
Top hat rail TH 35-7,5

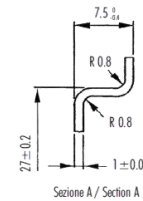

Sezione A / Section A

Profilato a cappello TH 35-15
Top hat rail TH 35-15

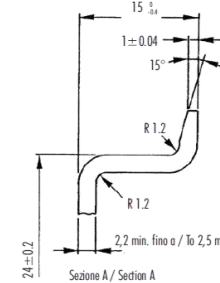

Sezione A / Section A



CARATTERISTICHE	METODO	UNITA' DI MISURA	BLENDE PC/ABS
Mecaniche			
Resistenza a trazione allo snervamento	ASTM D638	MPa	68
Resistenza a trazione a rottura	ASTM D638	MPa	48
Allungamento a rottura	ASTM D638	%	59
Modulo in flessione	ASTM D790	MPa	2894
Prova Load con intaglio	ISO 180/14	KJ/m ²	5.5
Termiche			
Temp. di ammolimento Vicat, metodo B	ASTM D1525	°C	114
Temperatura Ricetta 1.81 MPa	ASTM D648	°C	97
Fisiche			
Peso specifico	ASTM D792	gr/cm ³	1.21
Ritiro nello stampo	ASTM D955	%	0.4/0.6
Multiflow Index 260°C - 99N	ASTM D1238	gr/10'	11.1
Comportamento alla fiamma			
Autosostentanza (min di spessore)	UL94	-	V-0 (0.8)
Filo Inamidabile 3.2 mm	IEC 695.2.1	°C	980

Italtronic si riserva il diritto di modificare il materiale con cui realizza i propri prodotti senza obbligo di preavviso.

FEATURES	TEST METHOD	UNITS	BLENDE PC/ABS
Mechanical test			
Resistance to tensile stress at yield	ASTM D638	MPa	68
Tensile strength	ASTM D638	MPa	48
Ultimate elongation	ASTM D638	%	59
Flexing modulus	ASTM D790	MPa	2894
Load test notched	ISO 180/14	KJ/m ²	5.5
Thermal test			
Vicat softening temperature method B	ASTM D1525	°C	114
Reheating temperature 1.81 MPa	ASTM D648	°C	97
Physical test			
Specific gravity	ASTM D792	gr/cm ³	1.21
Mold shrinkage	ASTM D955	%	0.4/0.6
Multiflow Index 260°C - 99N	ASTM D1238	gr/10'	11.1
Flame test			
Self extinguisher (thickness in mm)	UL94	-	V-0 (0.8)
Inamidable thread 3.2 mm	IEC 695.2.1	°C	980

Italtronic can operate any change of the materials without being obliged to forewarn.



INDUSTRIAL SHIELDS

About Industrial Shields:

Direction: Fàbrica del Pont, 1-11

Zip/Postal Code: 08272

City: Sant Fruitós de Bages (Barcelona)

Country: Spain

Telephone: (+34) 938 760 191 / (+34) 635 693 611

Mail: industrialshields@industrialshields.com