



LINE TRACKING ROBOT

LIGHTING SENSOR ROBOT KIT

Assembly and Instruction Manual

Contents

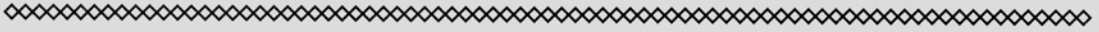

Line Tracking Robot:

1. Product Introduction	P.1
2. Tools You May Need	P.1
3. Mechanical Parts List	P.1
4. Plastic Parts	P.3
5. Mechanical Assembly	P.3
How it works	P.10
Trouble Shooting	P.11
Circuit Diagram	P.11



LINE TRACKING ROBOT

1 Product Introduction:

Line Tracking Robot will follow a black line on white ground by using 2 photo interrupters as its eyes. The 2 photo interrupters will distinguish black and white by projecting infrared rays.

Power source:

Voltage / Electrical / Mechanical:

1.5 V " AA " x 2 (not included)

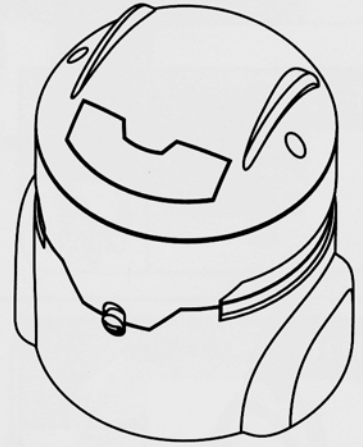

2 Tools You May Need:

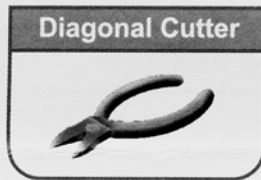
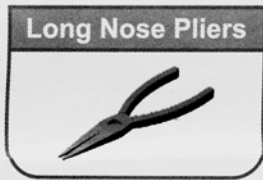

3 Mechanical Parts List:

P1	Motor
	Qty 1

P2	Motor
	Qty 1

P3	Pinion Gear 10T
	Qty 2

P4	Face Gear 36T/14T
	Qty 2 (White)

P5	Gear 36T/14T
	Qty 2 (Green)

P6	Gear 36T/14T
	Qty 2 (Red)

P7	Round Shaft With Gear 36T/0T
	Qty 2 (White)

P8	Post
	Qty 2

P9	Round Shaft
	Qty 1 (2x40)

P10	Eyelet	Qty
		4

P11	Tapping Screw	Qty
		8 (2.6x14)

P12	Tapping Screw With Washer	Qty
		2 (2.6x6)

P13	Tapping Screw	Qty
		9 (2.3x7)

P14	Tapping Screw	Qty
		1 (2.6x7)

P15	Wheel	Qty
		2

P16	Tire	Qty
		2

P17	Steel Ball	Qty
		1

P18	Battery Holder	Qty
		1

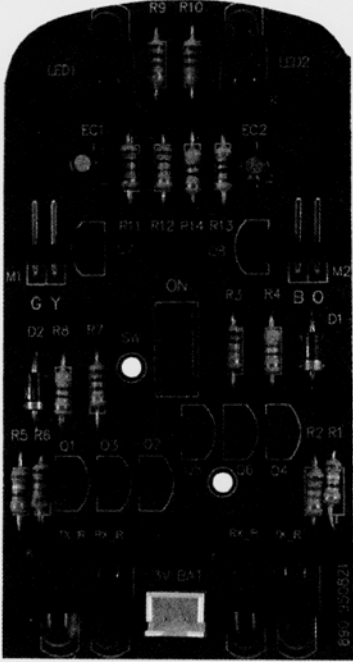
P19	Finished PCB
	

4 Plastic Parts:

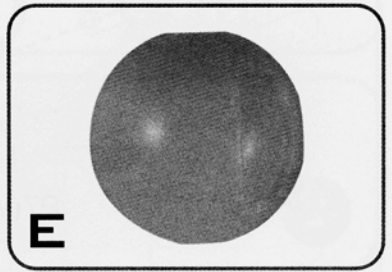
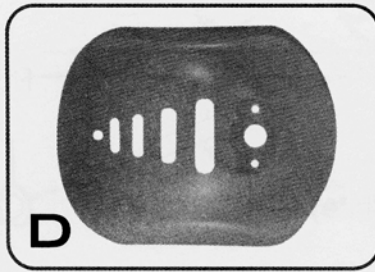
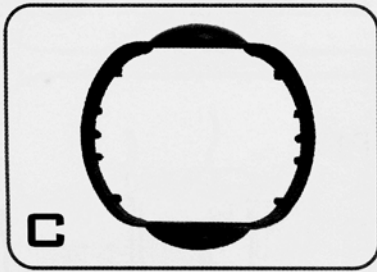
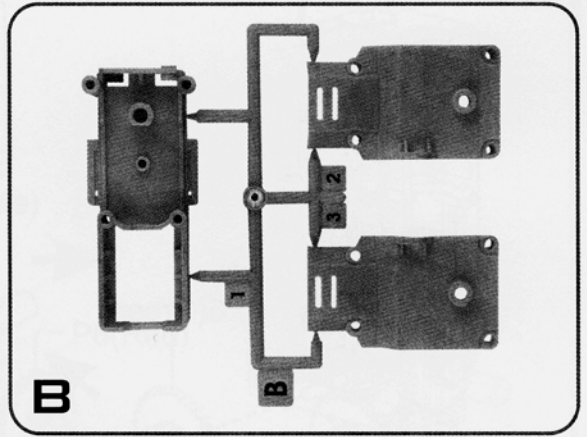
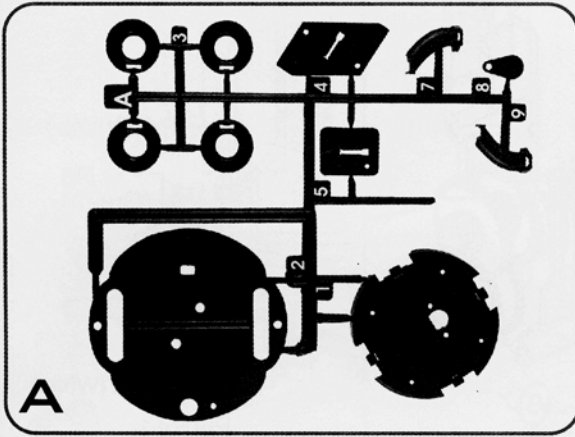

5 Mechanical Assembly:

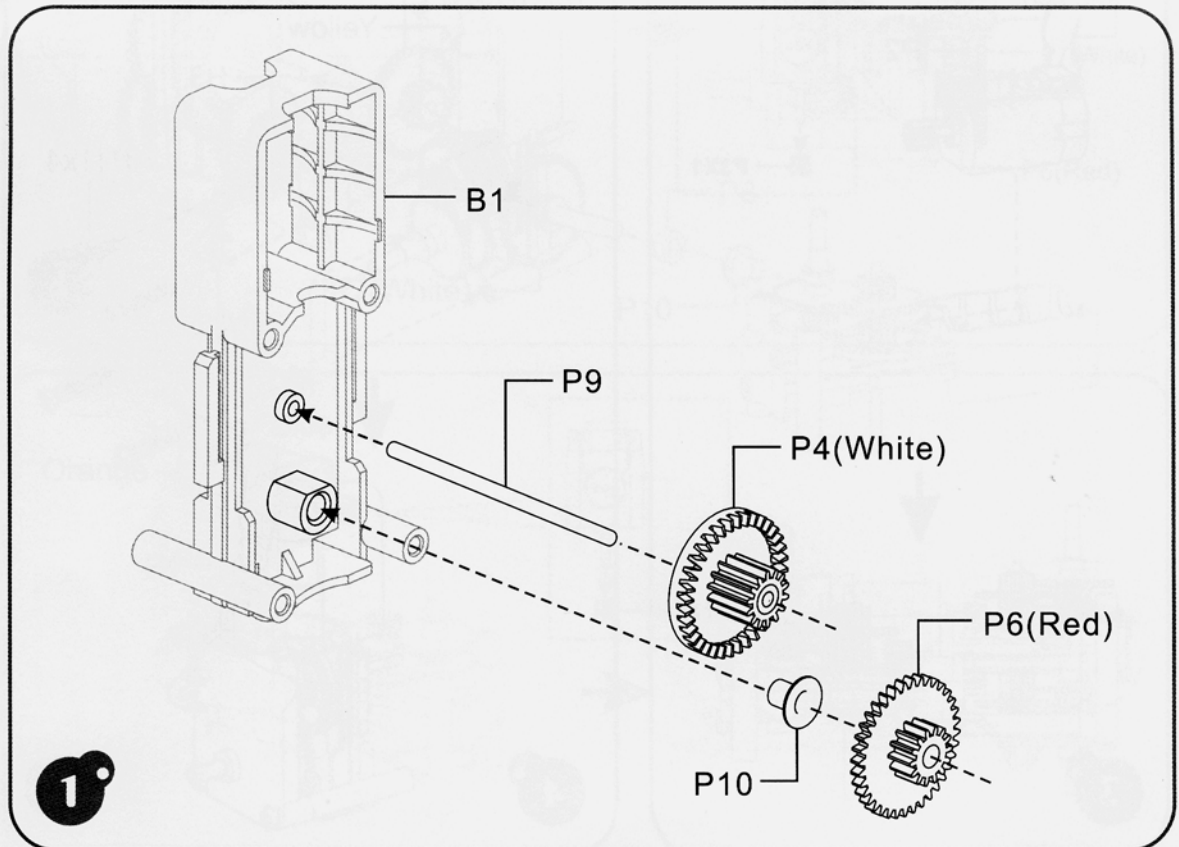

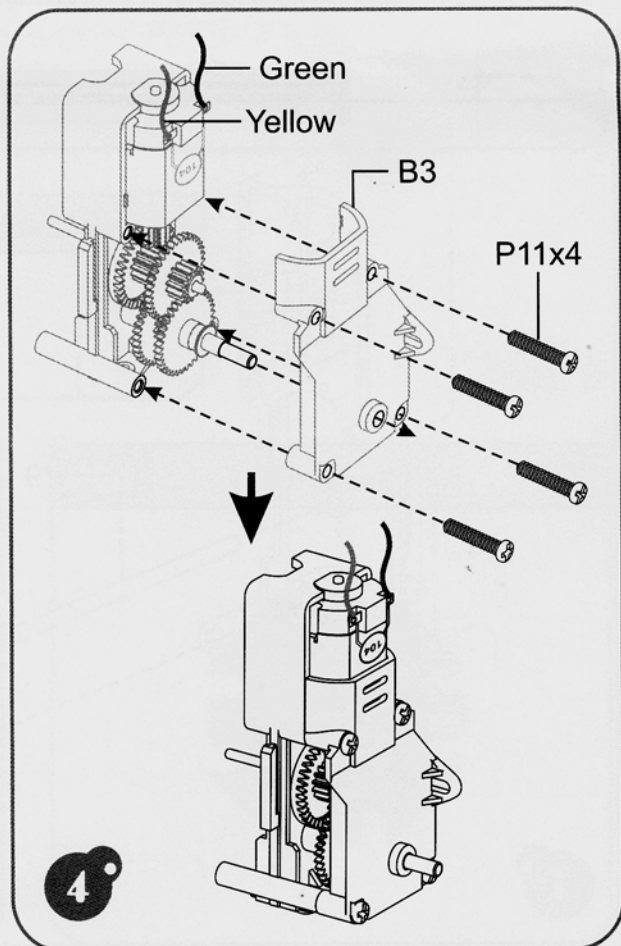
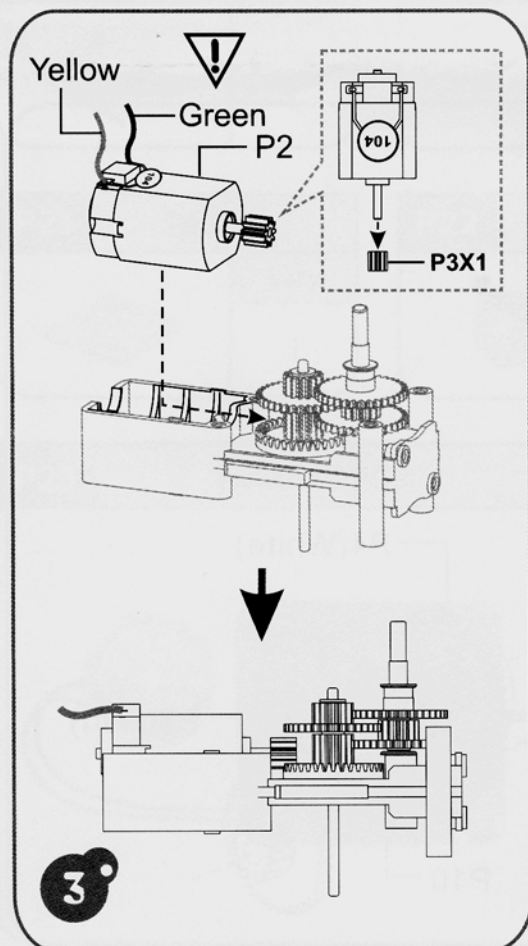
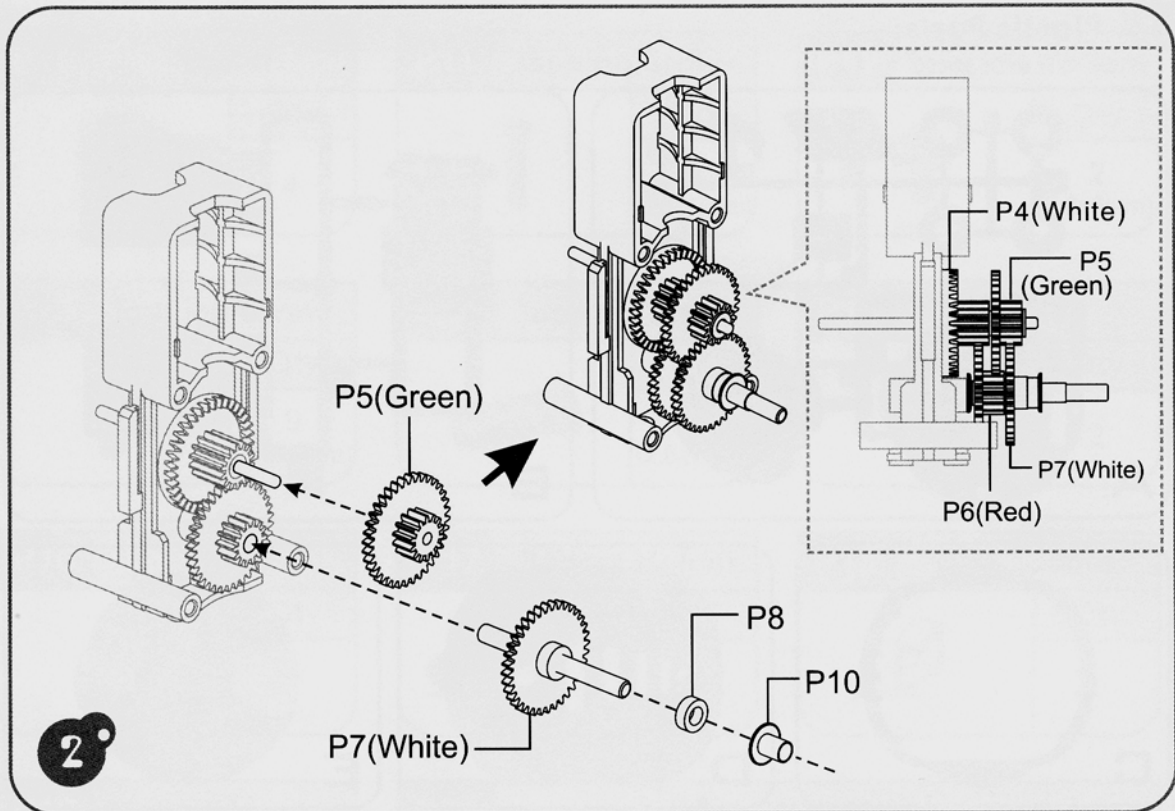

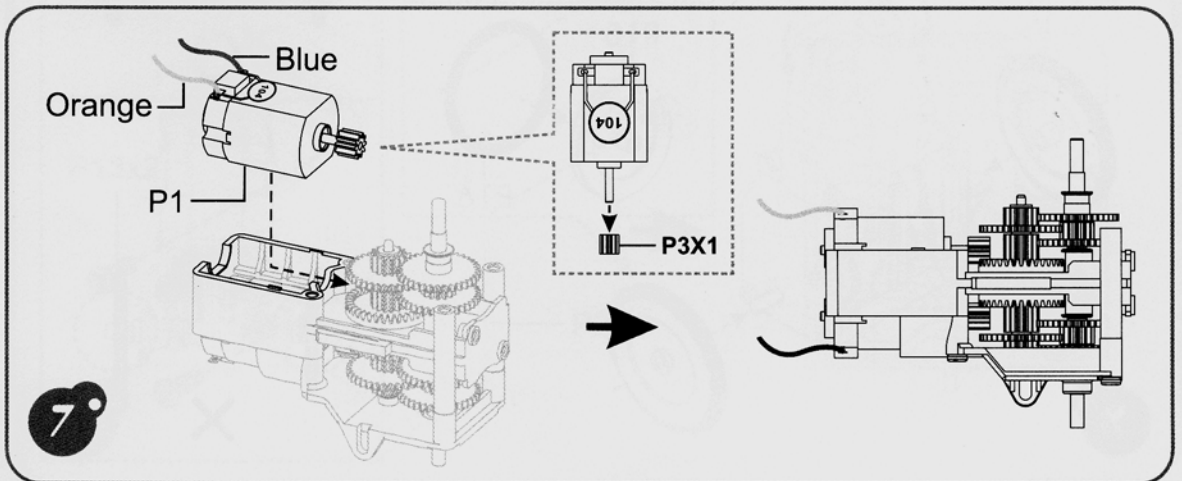
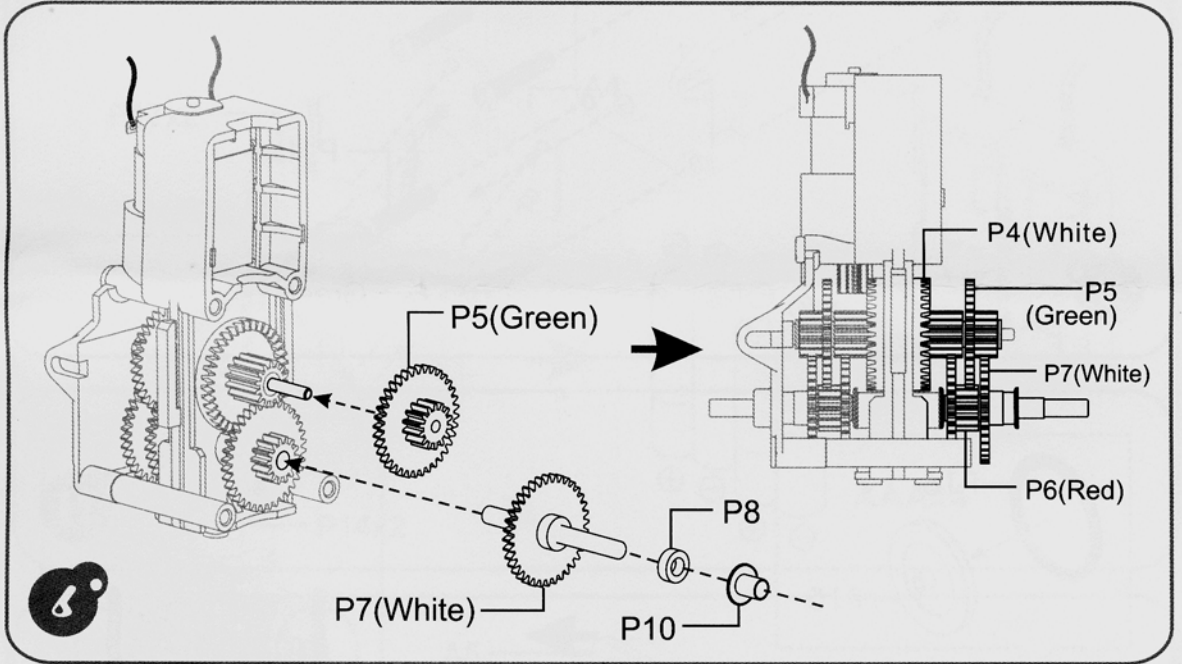
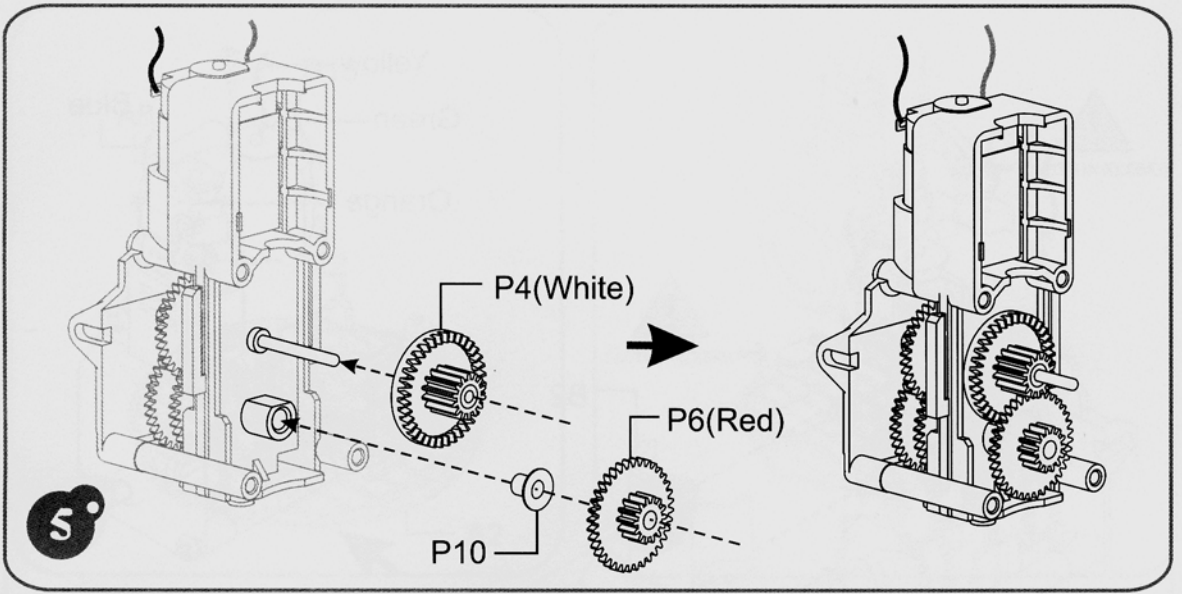

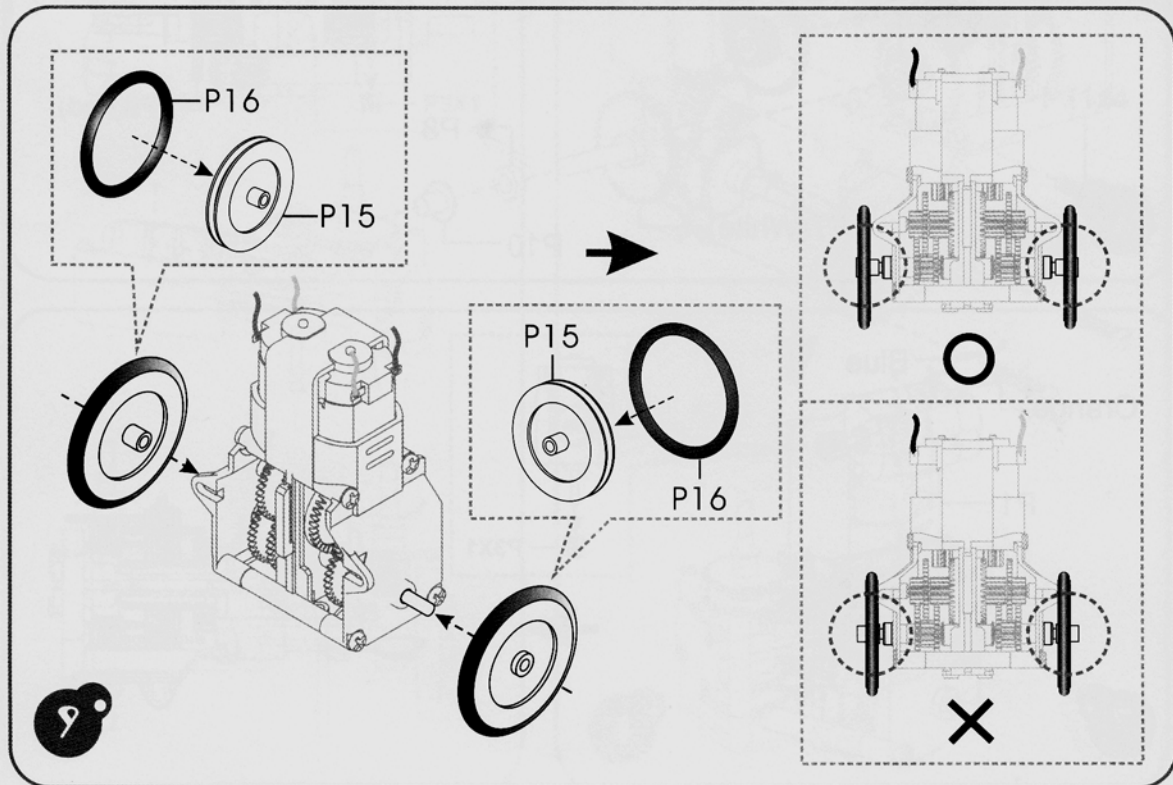
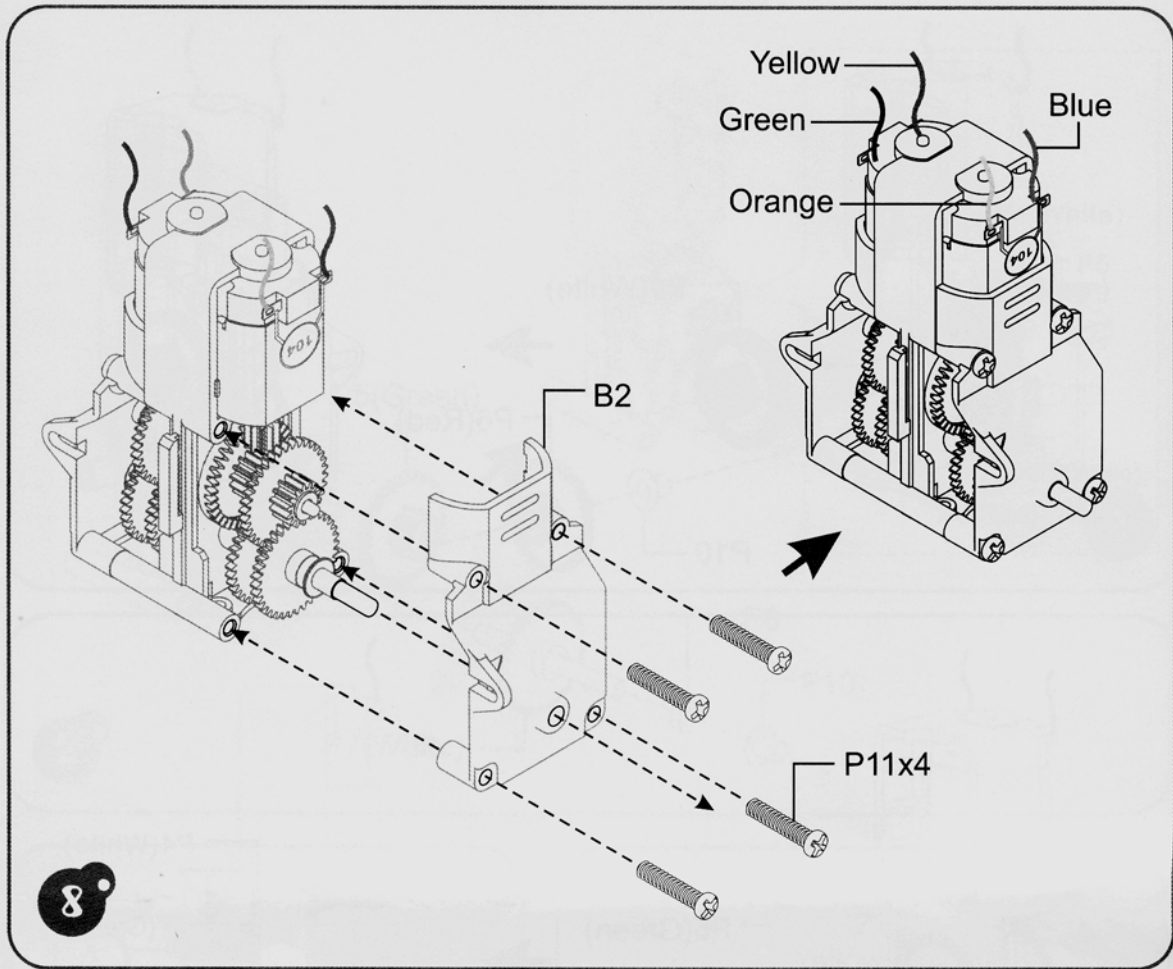

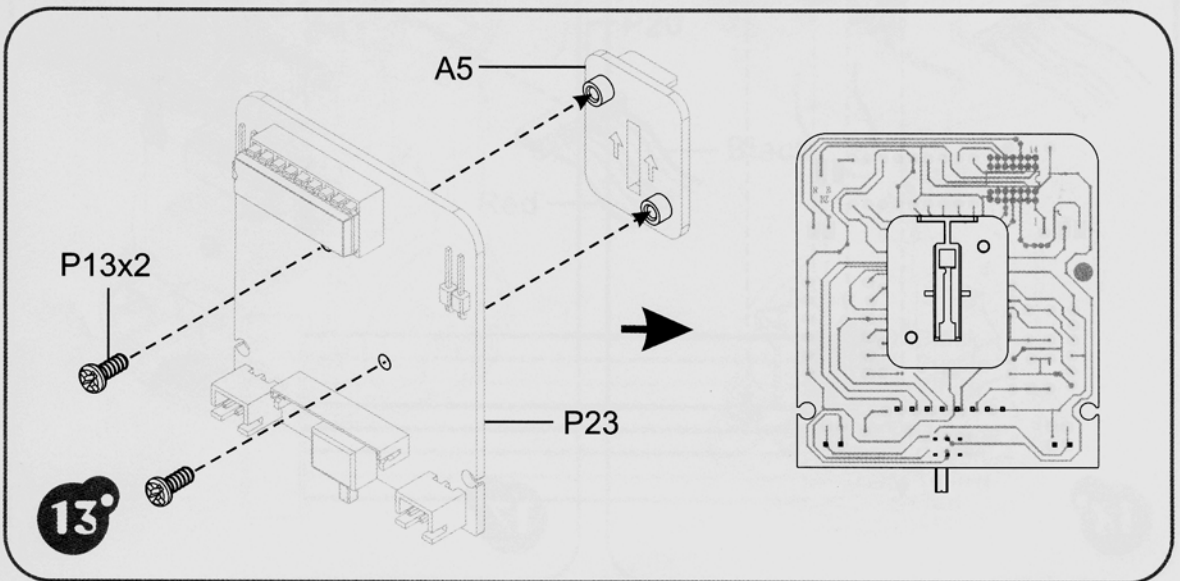
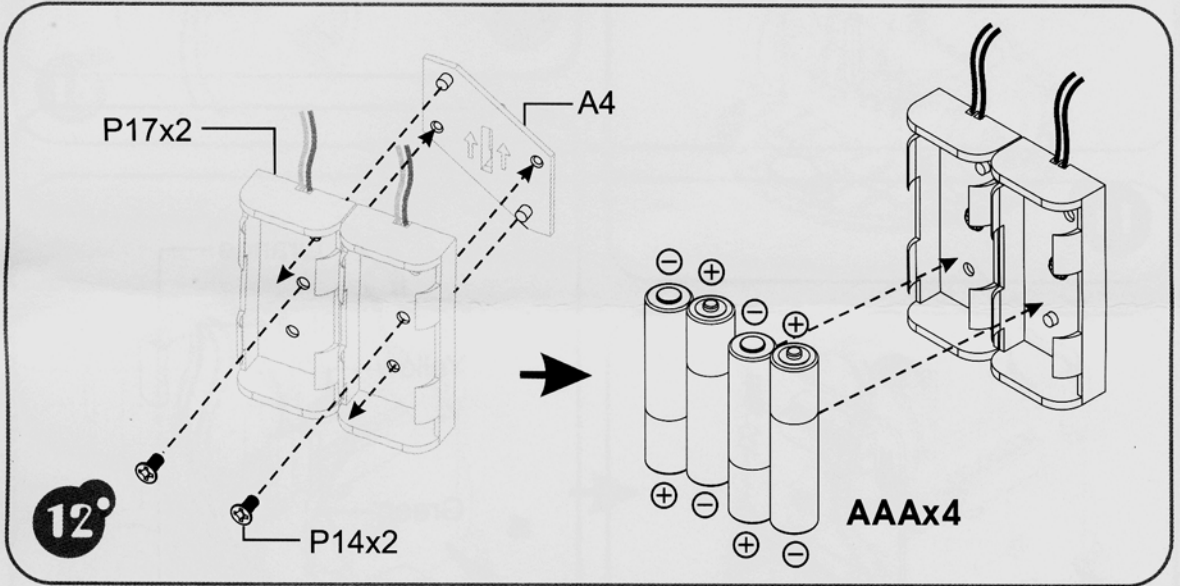
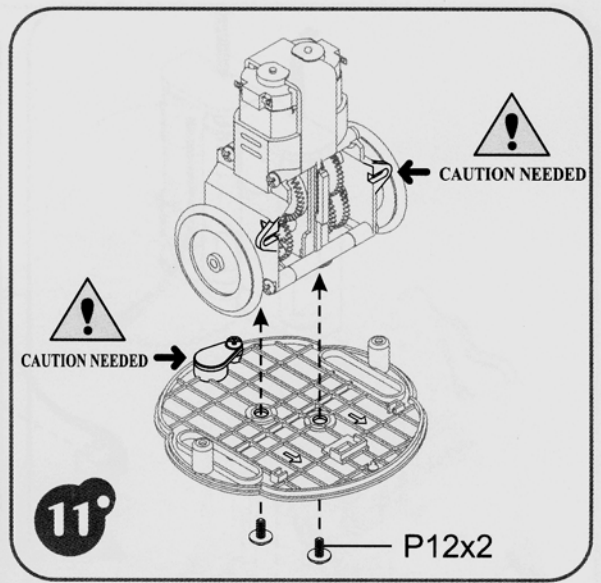
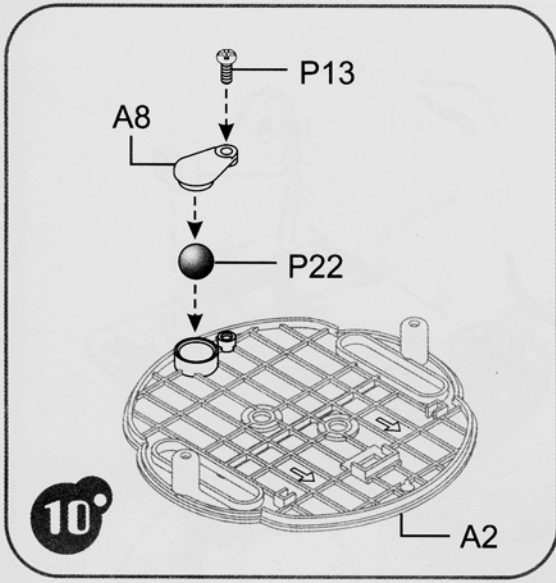

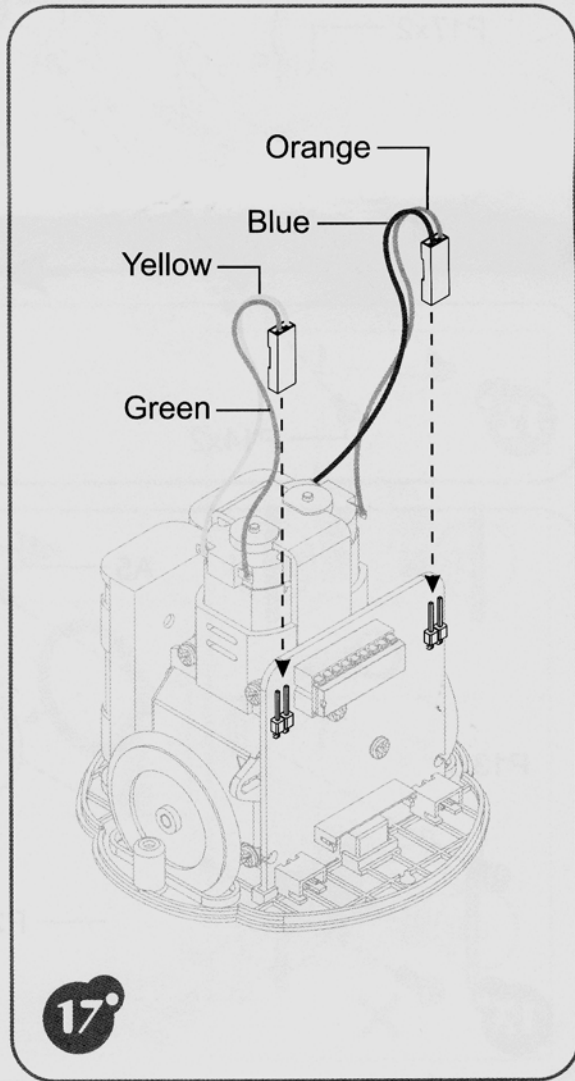
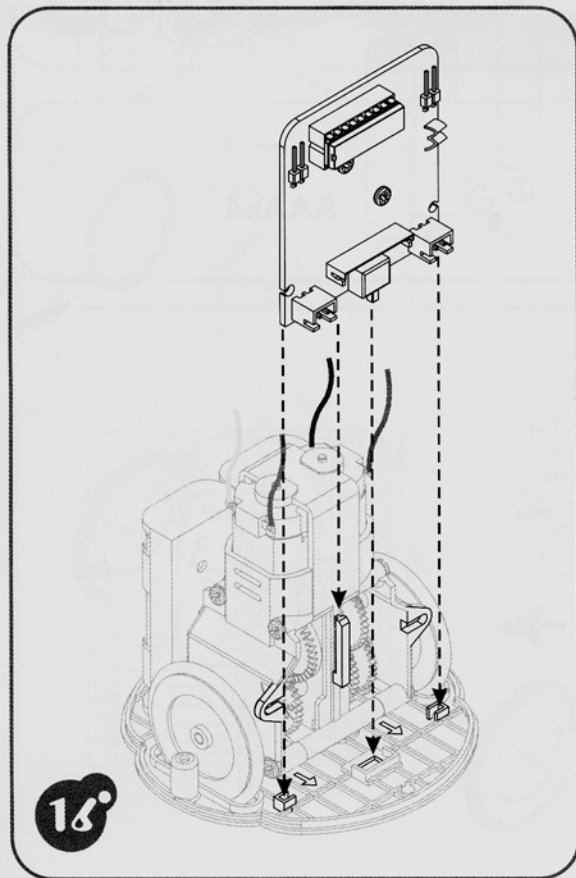
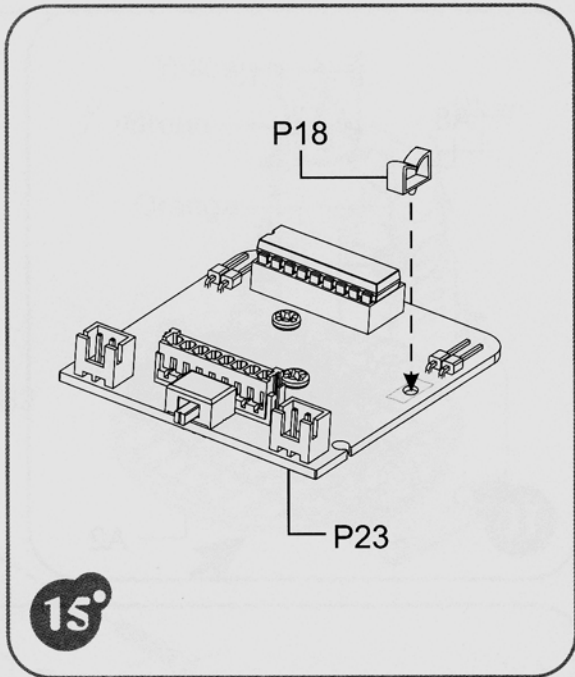
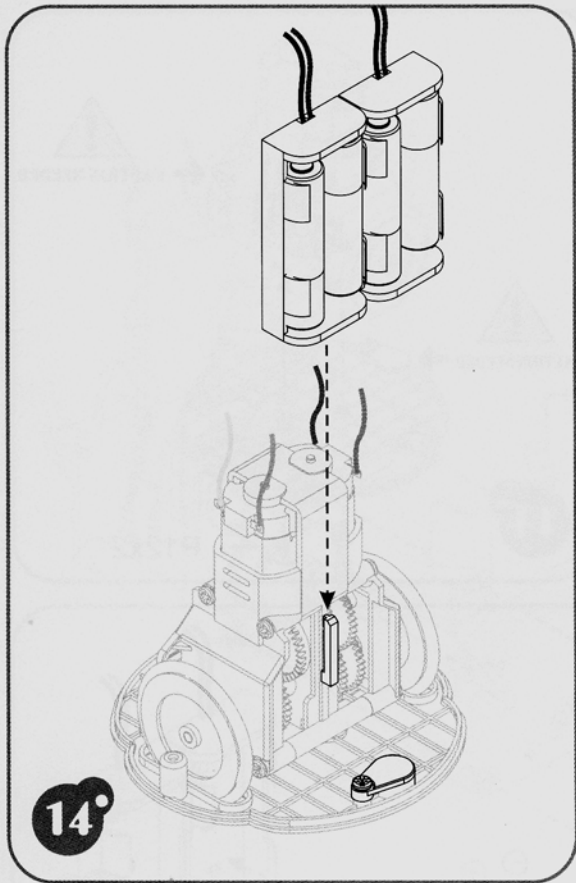

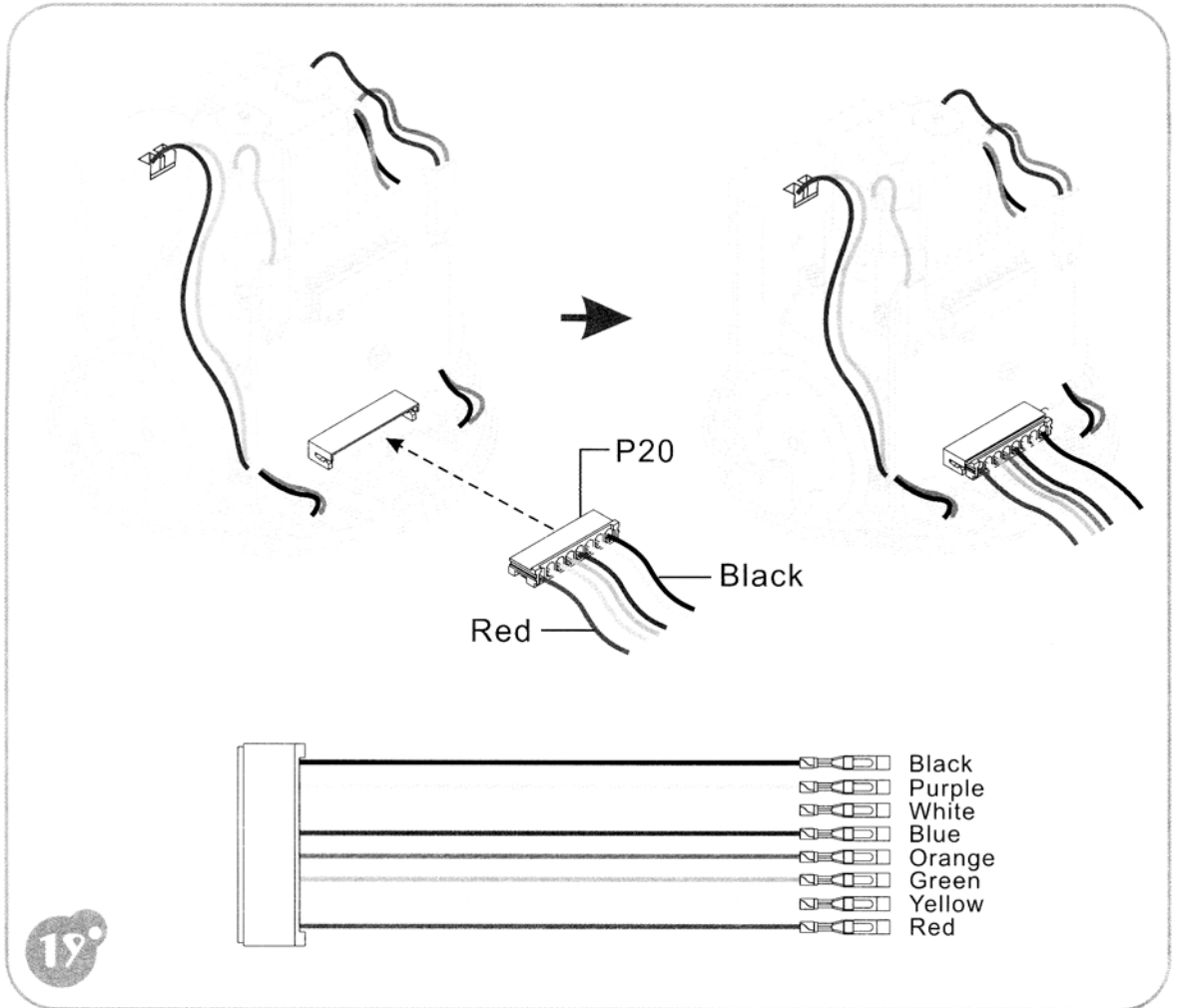
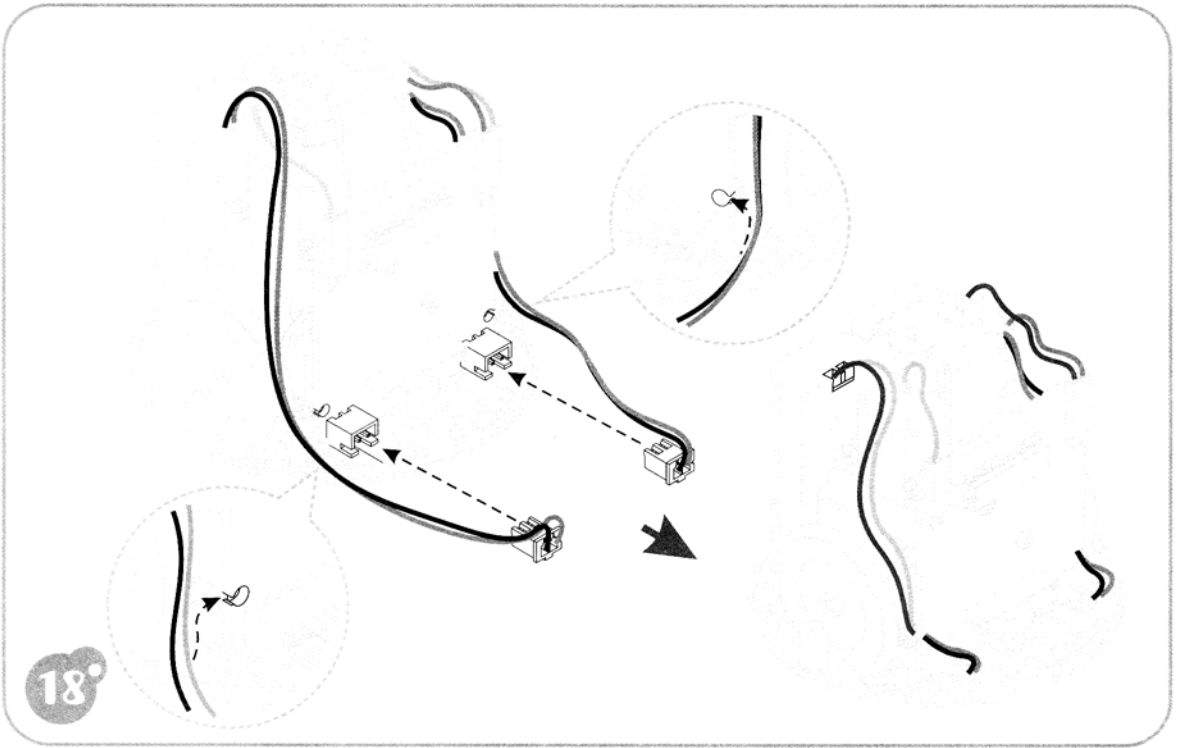

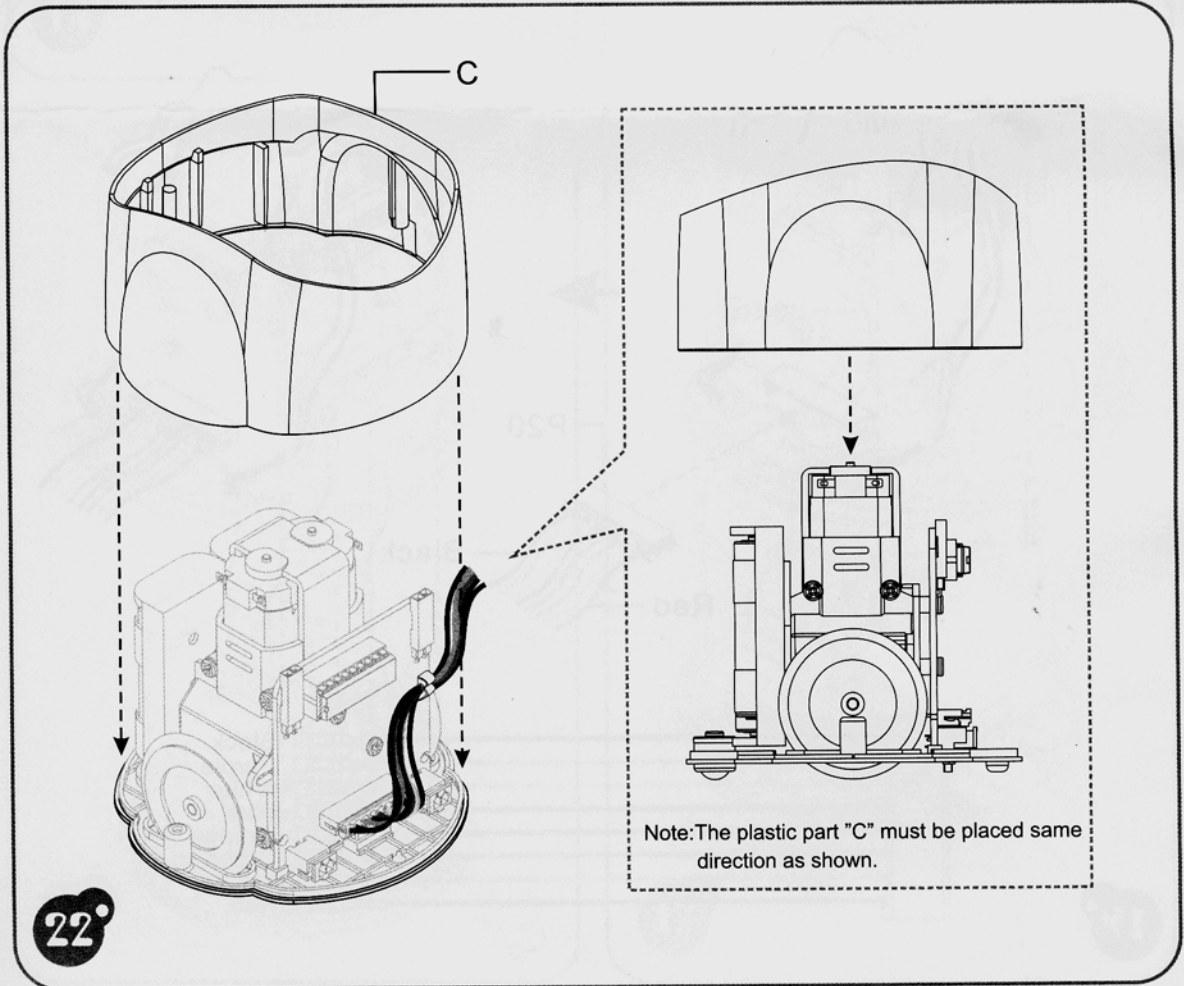
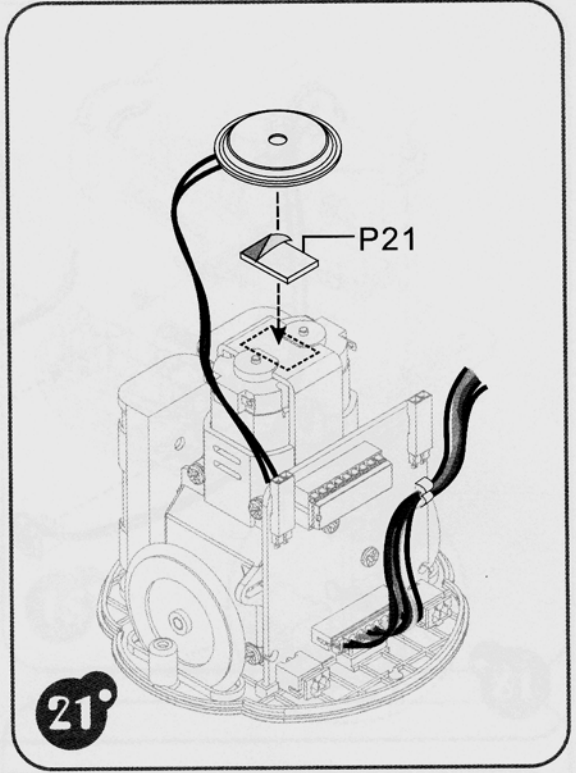
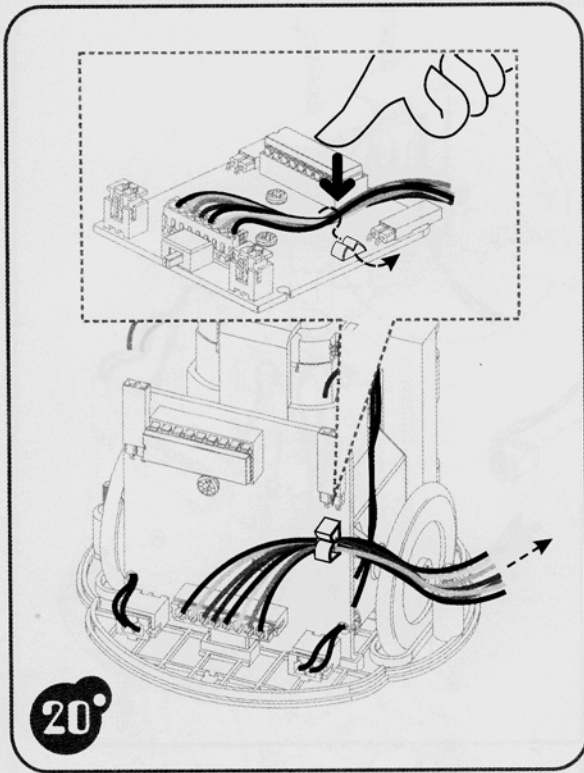

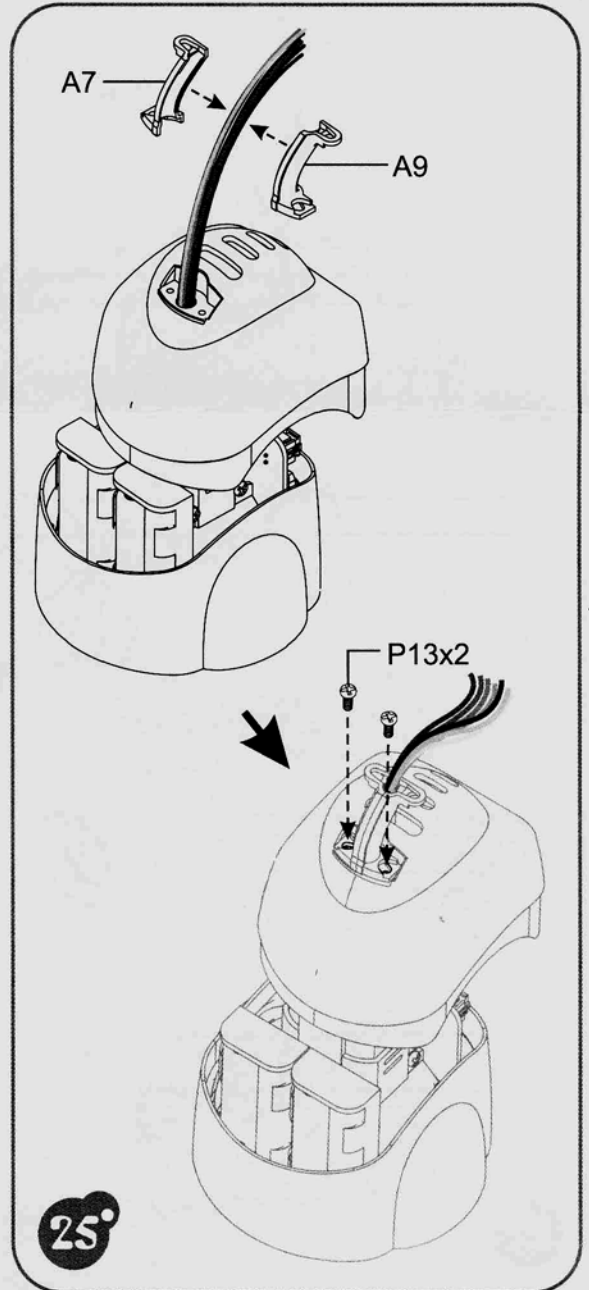
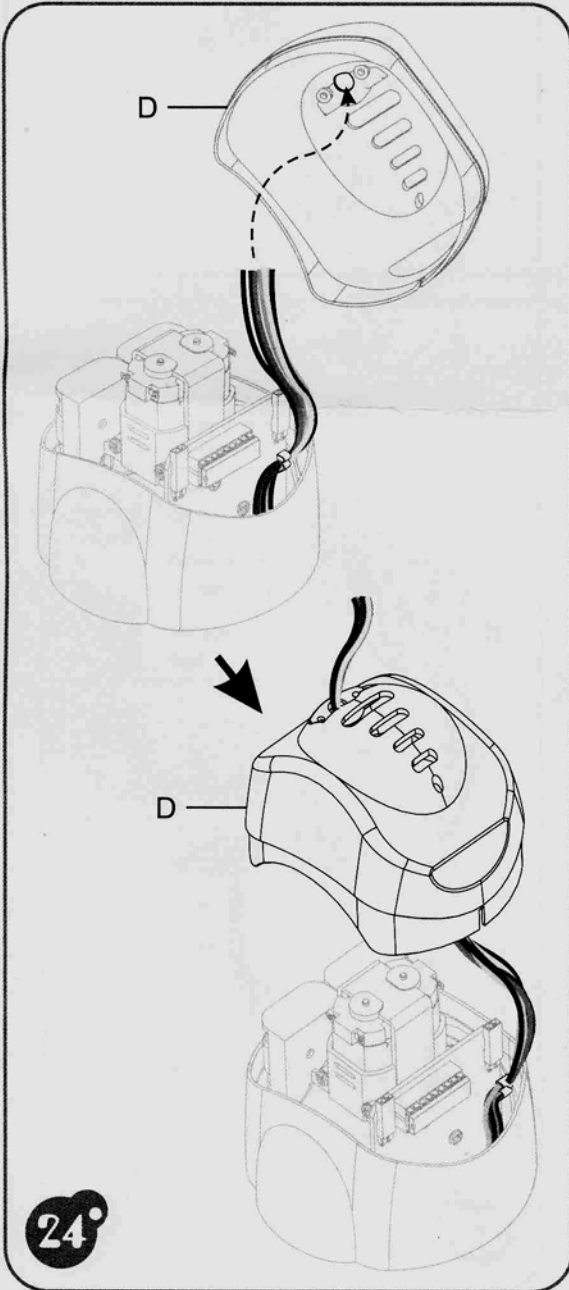
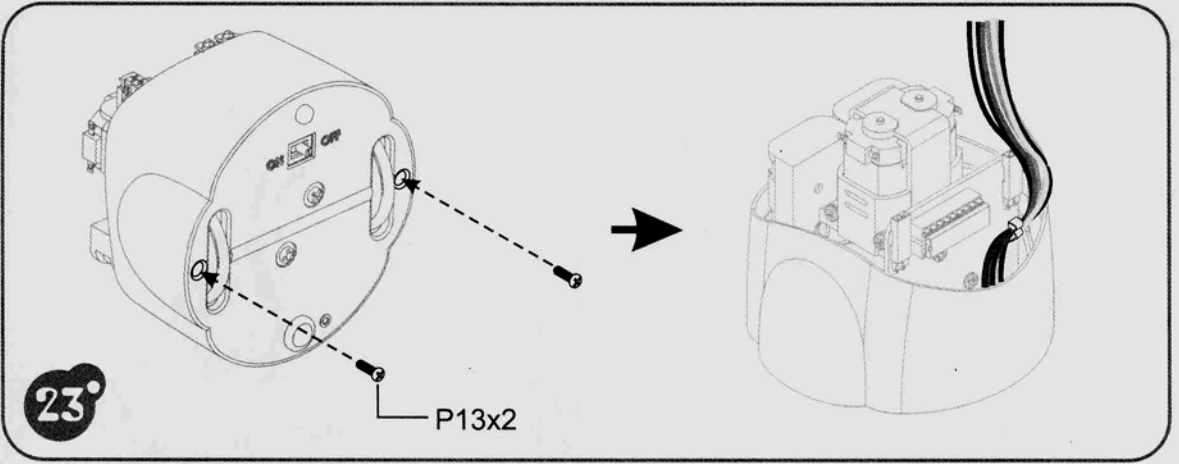

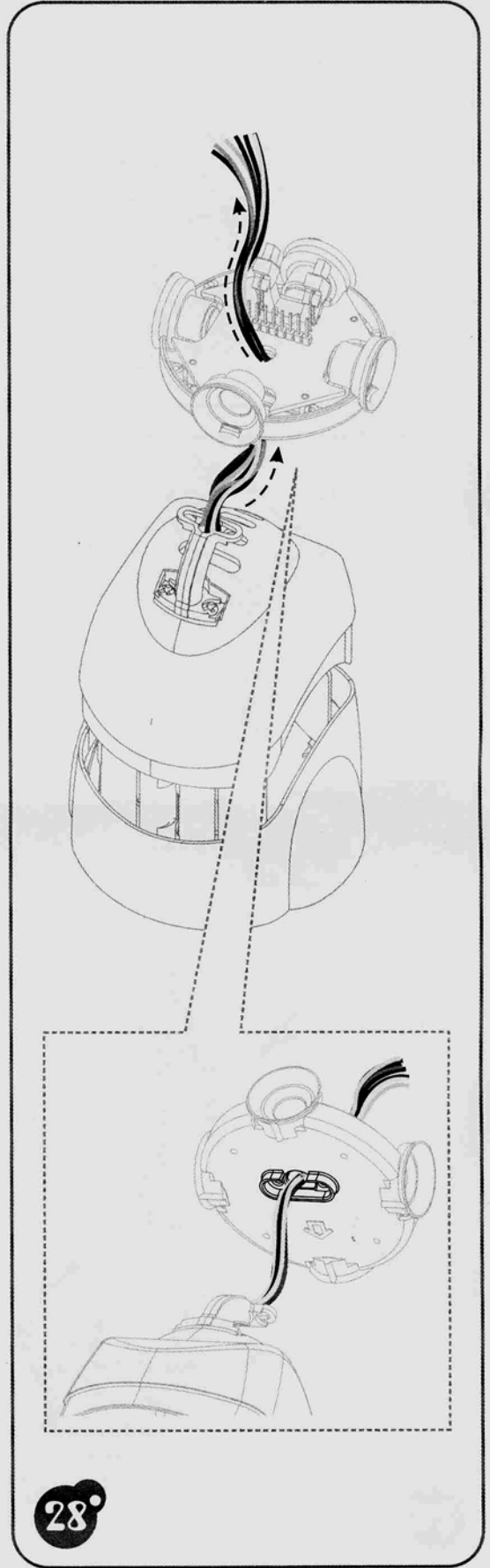
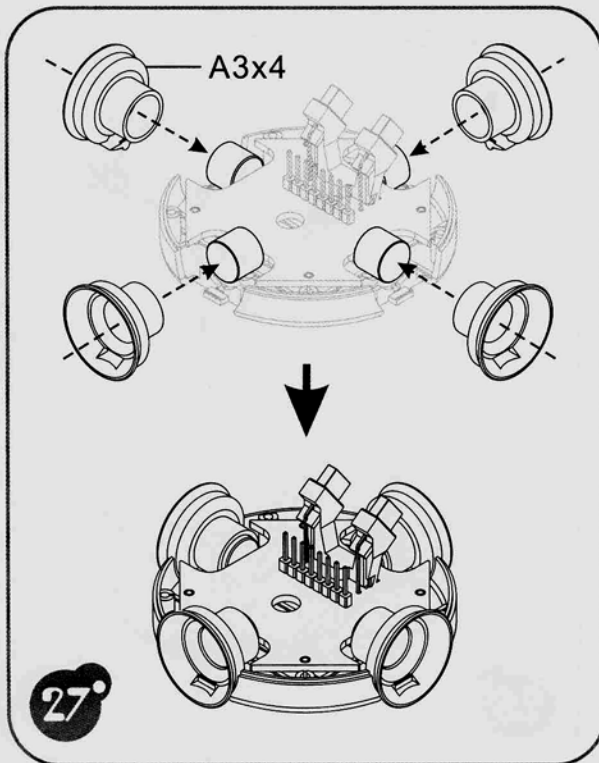
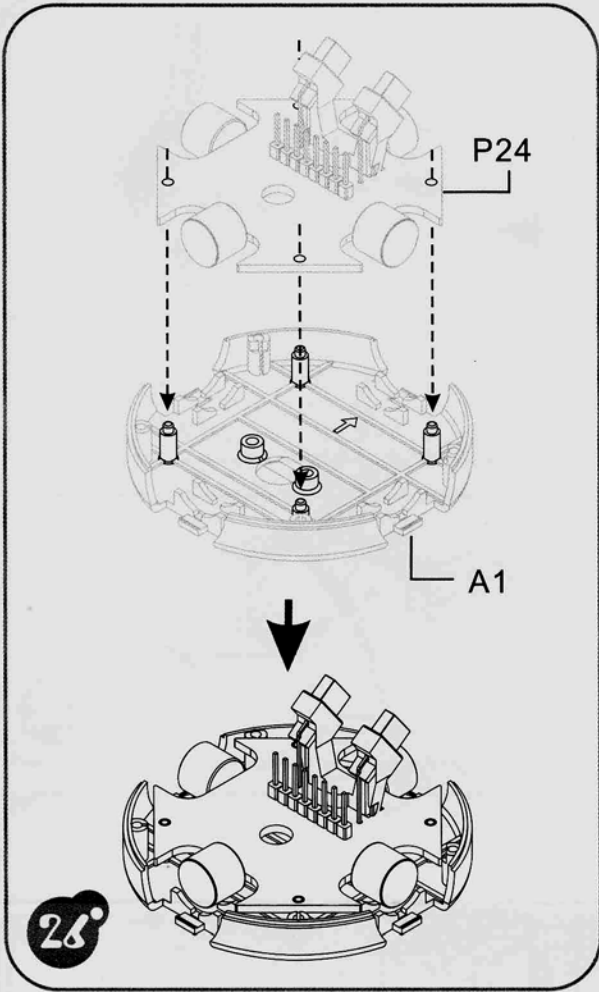

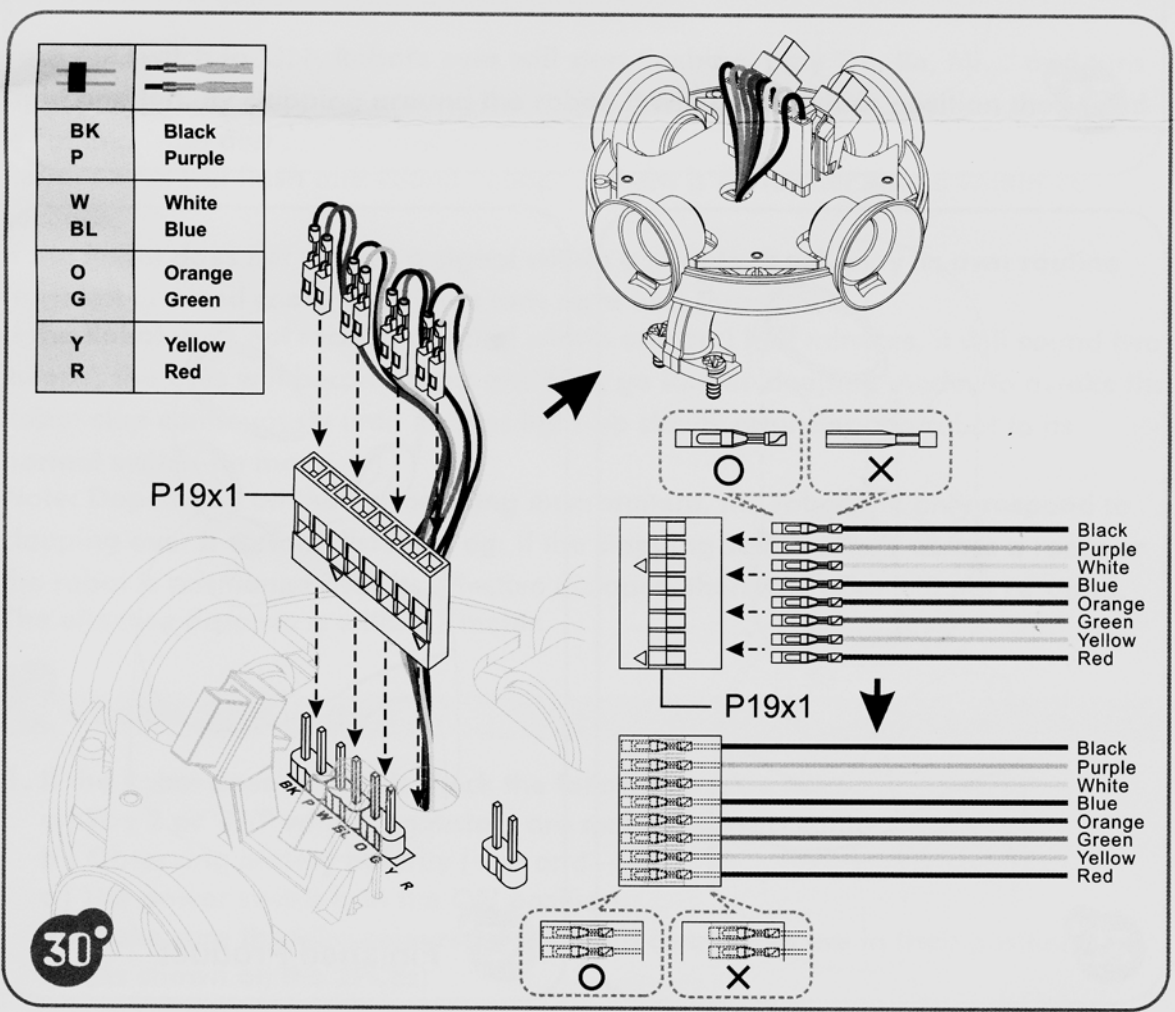
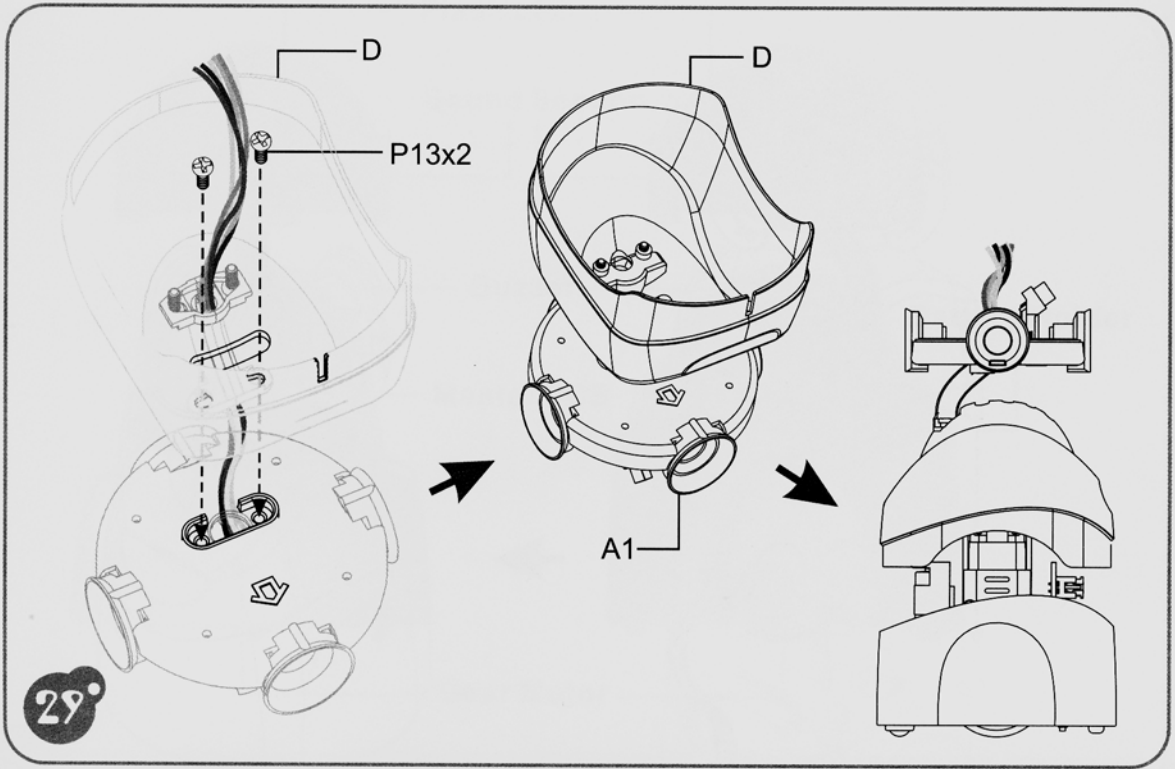

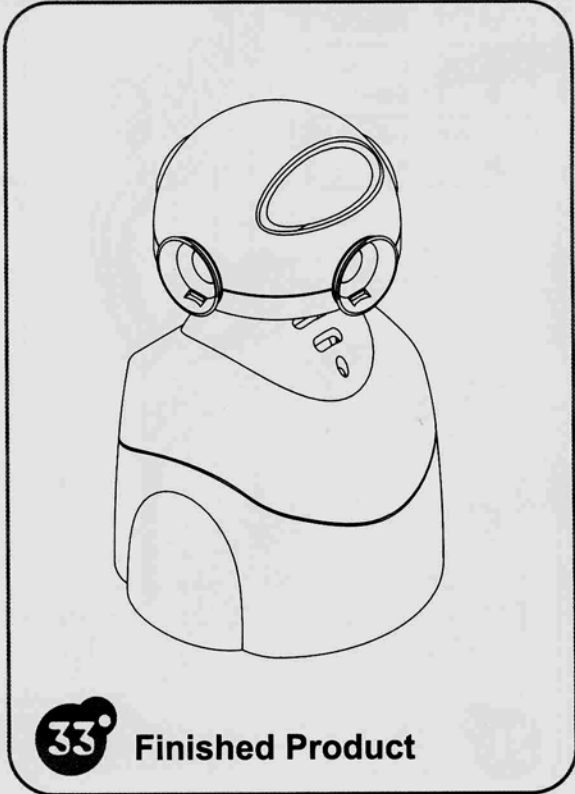
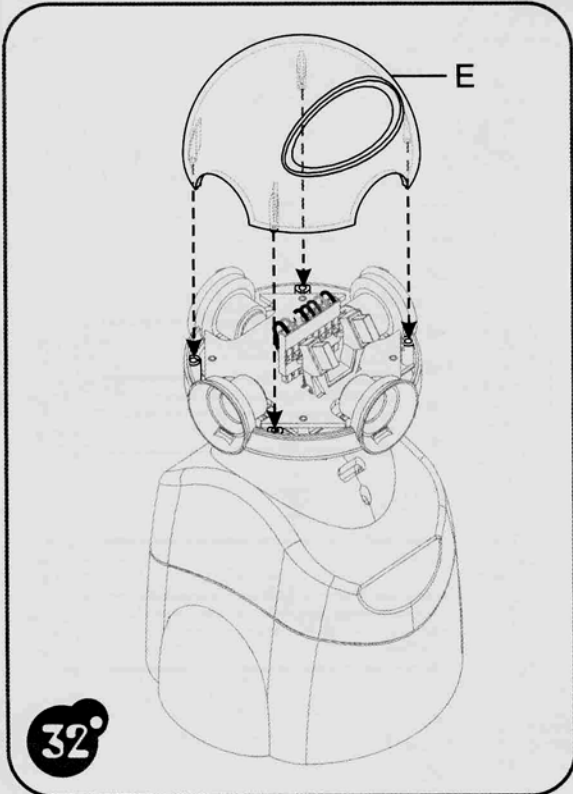
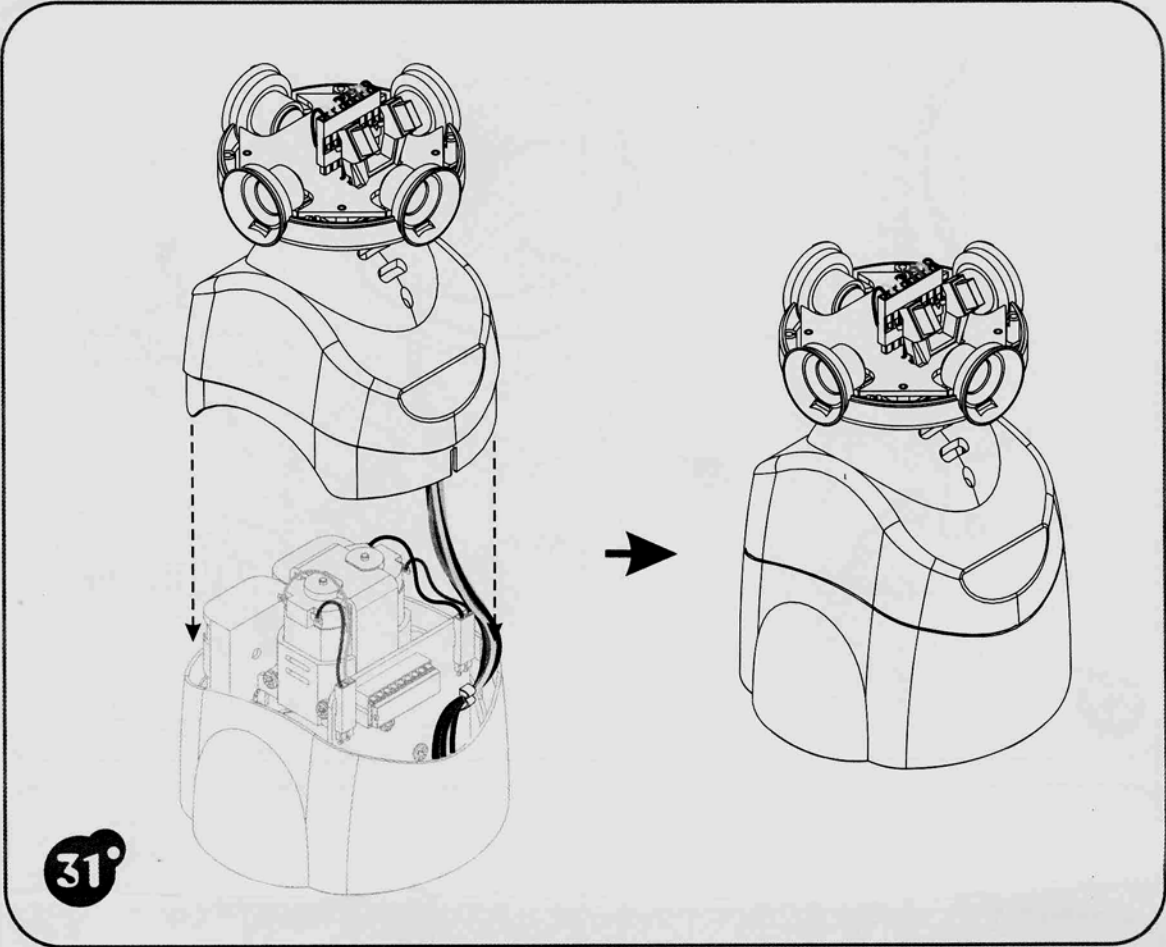

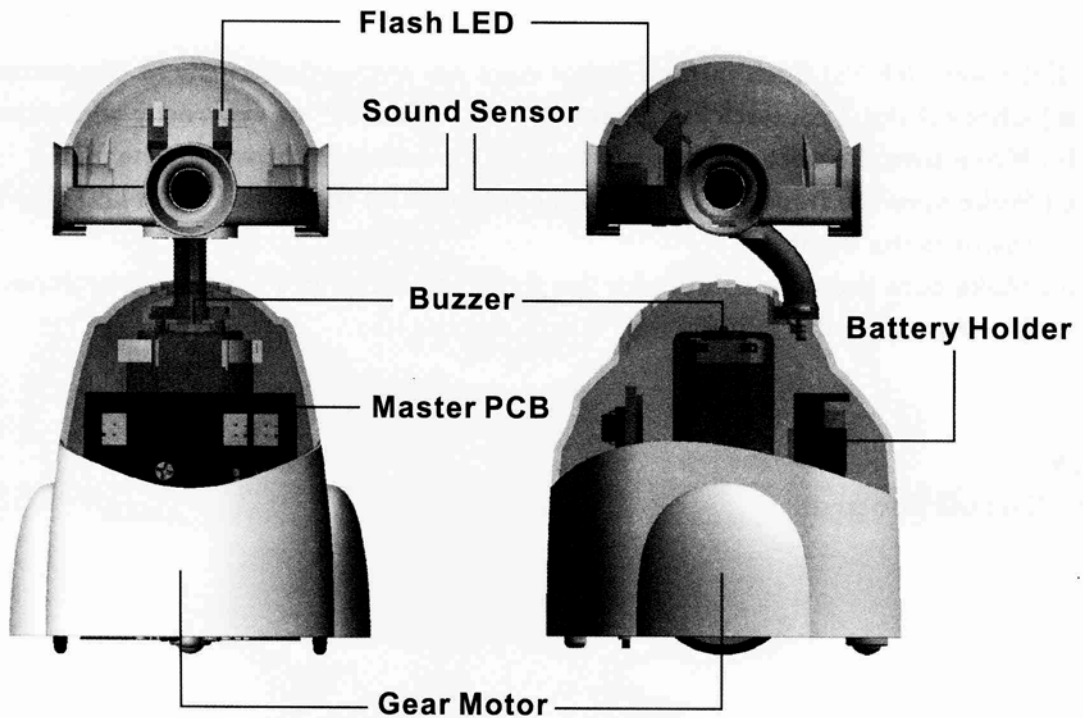

6 How It Works:

Turn the switch to 'ON', Robot's eyes will start flashing, play 'Do, Re, Mi...' and turn right and left. By clapping around the robot, it will detect which position the sound is coming from and turn its way towards it.

Robot's eyes will flash and sound "beep" if there is no further sound within 10 seconds.

If the Robot does not receive a signal within a minute, it will play its own routine (turn left first and come back, then turn right and come back).

If the Robot does not receive a signal within one and half minutes, it will sound two 'beeps', the eyes will become dark and then go into its sleeping mode. To awake the Robot clap continuously until its eyes light-up slowly returning the robot to its normal switch-on mode.

Note: Depending on the surrounding environment, the robot will only respond to clapping over a certain distance, eg: if the clapping sound echo's across a room or the robot is positioned over its effective distance, then the robot will not respond. The effective distance is within 1 meter.

7 Trouble Shooting:

1. If the Robot does not work check the following:
 - a) The 2 pc 'BAT' white connectors are making correct contact
 - b) Observing battery polarity (+ve and -ve)
 - c) The power switch is in the ON position.
 - d) Make sure the wire colours on the 8 pin connectors are in their position.
(As shown on the 2PCBs)

2. If the eyes (LED's) flash but the Robot does not respond correctly to clapping:
- a) Check if the 2 connectors "R-motor" and "L-motor" are correctly connected.
 - b) Make sure the wire colours are the same as what is shown on the PCB.
 - c) Make sure the head PCB is correctly mounted ie: the eyes (green LED's) are towards the front.
 - d) Make sure the wire colours for the 8 pin connector are correctly positioned.
(As shown on the 2 PCBs)

8 Circuit Diagram:

