

# Miniature Linear Motion Series • L12

Firgelli Technologies' unique line of Miniature Linear Actuators enables a new generation of motion-enabled product designs, with capabilities that have never before been combined in a device of this size. These small linear actuators are a superior alternative to designing with awkward gears, motors, servos and linkages.

Firgelli's L series of micro linear actuators combine the best features of our existing micro actuator families into a highly flexible, configurable and compact platform with an optional sophisticated on-board microcontroller. The first member of the L series, the L12, is an axial design with a powerful drivetrain and a rectangular cross section for increased rigidity. But by far the most attractive feature of this actuator is the broad spectrum of available configurations.



## L12 Specifications

Gearing Option	50	100	210	
Peak Power Point <sup>1</sup>	12 N @ 11 mm/s	23 N @ 6 mm/s	45 N @ 2.5 mm/s	
Peak Efficiency Point	6 N @ 16 mm/s	12 N @ 8 mm/s	18 N @ 4 mm/s	
Max Speed (no load)	23 mm/s	12 mm/s	5 mm/s	
Backdrive Force <sup>2</sup>	43 N	80 N	150 N	
Stroke Option	10 mm	30 mm	50 mm	100 mm
Weight	28 g	34 g	40 g	56 g
Positional Accuracy	0.1 mm	0.2 mm	0.2 mm	0.3 mm
Max Side Force (fully extended)	50 N	40 N	30 N	15 N
Mechanical Backlash	0.1 mm			
Feedback Potentiometer	2.75 kΩ/mm ± 30%, 1% linearity			
Duty Cycle	20 %			
Lifetime	1000 hours at rated duty cycle			
Operating Temperature	-10°C to +50°C			
Storage Temperature	-30°C to +70°C			
Ingress Protection Rating	IP-54			
Audible Noise	55 dB at 45 cm			
Stall Current	450 mA at 5 V & 6 V, 200 mA at 12 V			

## Benefits

- Compact miniature size
- Simple control using industry standard interfaces
- Low voltage
- Equal push / pull force
- Easy mounting

## Applications

- Robotics
- Consumer appliances
- Toys
- Automotive
- Industrial automation

## Dimensions (mm)

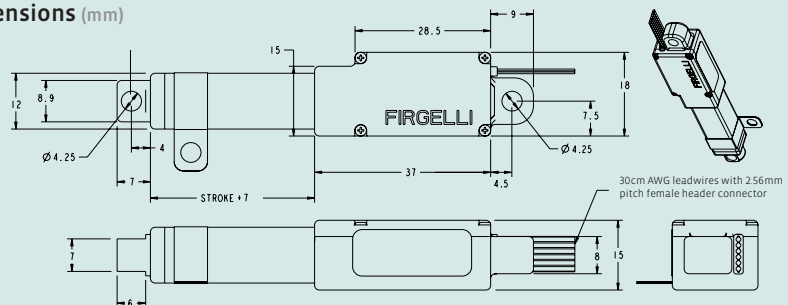

## Firgelli Technologies Inc.

4585 Seawood Tce.  
Victoria, BC V8N 3W1  
Canada

1 (206) 347-9684 phone

1 (888) 225-9198 toll-free

1 (206) 347-9684 fax

sales@firgelli.com

www.firgelli.com

## L12 Specifications

Load Curves

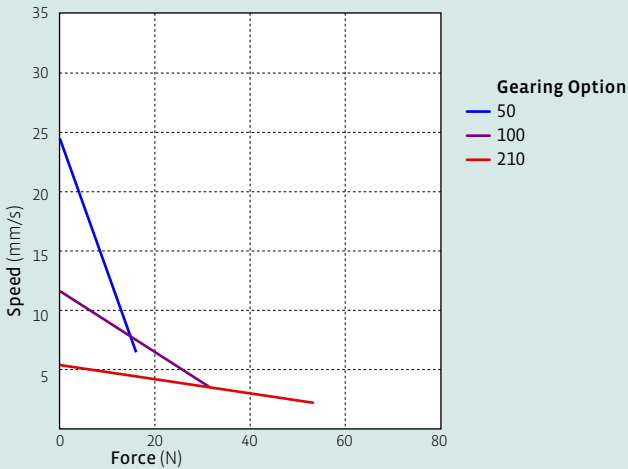

Current Curves

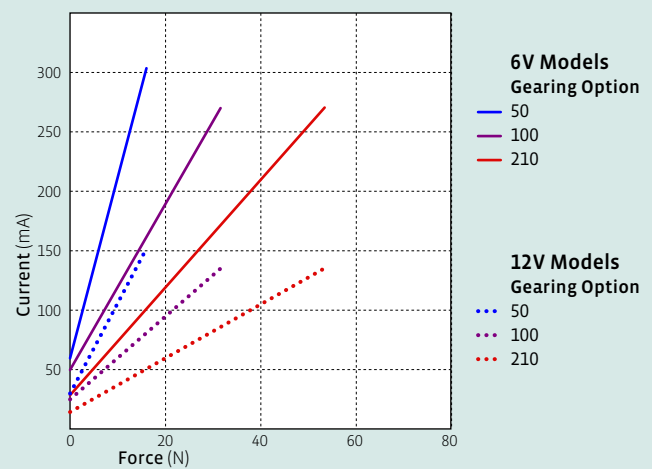

## Model Selection

The L12 has five configurable features. L12 configurations are identified according to the following scheme:

### L12-SS-GG-VV-C-L

feature	options
<b>SS:</b> Stroke Length (in mm)	<b>10, 30, 50, 100</b> Any stroke length between 10 and 100mm is available on custom orders, in 2mm increments.
<b>GG:</b> Gear reduction ratio (refer to force/speed plots)	<b>50, 100, 210</b> Other gearing options may be possible on custom orders.
<b>VV:</b> Voltage	<b>06</b> 6V (5V power for Controller options B and P) <b>12</b> 12V
<b>C:</b> Controller	<b>B</b> Basic 2-wire open-loop interface, no position feedback, control, or limit switching. Positive voltage extends, negative retracts. <b>S</b> 2-wire open-loop interface (like B option) with limit switching at stroke endpoints. <b>P</b> Simple analog position feedback signal, no on-board controller. <b>I</b> Integrated controller with Industrial and RC servo interfaces (see L12 Controller Options section). Not available with 10mm stroke length configurations. <b>R</b> RC Linear Servo. Not available with 10mm stroke or 12 volts.
<b>L:</b> Mechanical or electrical interface customizations	Custom option codes will be issued by Firgelli for custom builds when applicable.

## Basis of Operation

The L12 actuator is designed to move push or pull loads along its full stroke length. The speed of travel is determined by the gearing of the actuator and the load or force the actuator is working against at a given point in time (see Load Curves chart on this datasheet). When power is removed, the actuator stops moving and holds its position, unless the applied load exceeds the backdrive force, in which case the actuator will backdrive. Stalling the actuator under power for short periods of time (several seconds) will not damage the actuator. Do not reverse the supply voltage polarity to actuators containing an integrated controller (I controller option).

Each L12 actuator ships with two mounting clamps, two mounting brackets and two rod end options: a clevis end and a threaded end with nut (see drawing on page 4). When changing rod ends, extend the actuator completely and hold the round shaft while unscrewing the rod end. Standard lead wires are 28 AWG, 30 cm long with 2.56 mm (0.1") pitch female header connector (Hi-Tec™ and Futaba™ compatible). Actuators are a sealed unit (IP-54 rating, resistant to dust and water ingress but not fully waterproof).

## Ordering information

Sample quantities may be ordered with a credit card directly from [www.firgelli.com](http://www.firgelli.com).

Please contact Firgelli at [sales@firgelli.com](mailto:sales@firgelli.com) for volume pricing or custom configurations.

Note that not all configuration combinations are stocked as standard products. Please refer to [www.firgelli.com/orders](http://www.firgelli.com/orders) for current inventory.

## L12 Controller options

### Option B—Basic 2-wire interface

#### WIRING:

1 (red) **Motor V+** (5V or 12V)

2 (black) **Motor ground**

The –B actuators offer no control or feedback mechanisms. While voltage is applied to the motor V+ and ground leads, the actuator extends. If the polarity of this voltage is reversed, the actuator retracts. The 5V actuator is rated for 5V but can operate at 6V.

### Option S—Basic 2-wire interface

#### WIRING:

1 (red) **Motor V+** (5V or 12V)

2 (black) **Motor ground**

When the actuator moves to a position within 0.5mm of its fully-retracted or fully-extended stroke endpoint, a limit switch will stop power to the motor. When this occurs, the actuator can only be reversed away from the stroke endpoint. Once the actuator is positioned away from its stroke endpoint, normal operation resumes. For custom orders, limit switch trigger positions can be modified at the time of manufacture, in 0.5mm increments.

### Option P—Position feedback signal

#### WIRING:

1 (orange) **Feedback potentiometer negative reference rail**

2 (purple) **Feedback potentiometer wiper** (position signal)

3 (red) **Motor V+** (5V or 12V)

4 (black) **Motor ground**

5 (yellow) **Feedback potentiometer positive reference rail**

The –P actuators offer no built-in controller, but do provide an analog position feedback signal that can be input to an external controller. While voltage is applied to the motor V+ and ground leads, the actuator extends. If the polarity of this voltage is reversed, the actuator retracts. Actuator stroke position may be monitored by providing any stable low and high reference voltages on leads 1 and 5, and then reading the position signal on lead 2. The voltage on lead 2 will vary linearly between the two reference voltages in proportion to the position of the actuator stroke.

### Option I—Integrated controller with industrial and RC servo interfaces

#### WIRING:

1 (green) **Current input signal** (used for 4–20 mA interface mode)

2 (blue) **Voltage input signal** (used for the 0–5V interface mode and PWM interface modes)

3 (purple) **Position Feedback signal** (0–3.3 V, linearly proportional to actuator position)

4 (white) **RC input signal** (used for RC-servo compatible interface mode)

5 (red) **Motor V+** (+6 Vdc for 6 V models, +12 Vdc for 12 V models)

6 (black) **Ground**

The –I actuator models feature an on-board software-based digital microcontroller. The microcontroller is not user-programmable.

The six lead wires are split into two connectors. Leads 4, 5 and 6 terminate at a universal RC servo three-pin connector (Hi-Tec™ and Futaba™ compatible). Leads 1, 2 and 3 terminate at a separate, similarly sized connector.

When the actuator is powered up, it will repeatedly scan leads 1, 2, 4 for an input signal that is valid under any of the four supported interface modes. When a valid signal is detected, the actuator will self-configure to the corresponding interface mode, and all other interface modes and input leads are disabled until the actuator is next powered on.

**0–5V Interface Mode:** This mode allows the actuator to be controlled with just a battery, and a potentiometer to signal the desired position to the actuator – a simple interface for prototypes or home automation projects. The desired actuator position (setpoint) is input to the actuator on lead 2 as a voltage between ground and 5V. The setpoint voltage must be held on lead 2 until the desired actuator stroke position is reached. Lead 2 is a high impedance input.

**4–20 mA Interface Mode:** This mode is compatible with PLC devices typically used in industrial control applications. The desired actuator position (setpoint) is input to the actuator on lead 1 as a current between 4 mA and 20 mA. The setpoint current must be held on lead 1 until the desired actuator stroke position is reached.

**RC Servo Interface Mode:** This is a standard hobby-type remote-control digital servo interface (CMOS logic), compatible with servos and receivers from manufacturers like Futaba™ and Hi-Tec™. The desired actuator position is input to the actuator on lead 4 as a positive 5 Volt pulse width signal. A 1.0 ms pulse commands the controller to fully retract the actuator, and a 2.0 ms pulse signals full extension. If the motion of the actuator, or of other servos in your system, seems erratic, place a 1–4Ω resistor in series with the actuator's red V+ leadwire.

**PWM Mode:** This mode allows control of the actuator using a single digital output pin from an external microcontroller. The desired actuator position is encoded as the duty cycle of a 5 Volt 1 kHz square wave on actuator lead 2, where the % duty cycle sets the actuator position to the same % of full stroke extension. The waveform must be 0V to +5V in order to access the full stroke range of the actuator.

### Option R—RC Linear Servo

#### WIRING:

1 (white) **RC input signal**

2 (red) **Motor V+** (6VOC)

3 (black) **Ground**

The –R actuators or 'linear servos' are a direct replacement for regular radio controlled hobby servos. Operation is as above in RC servo interface mode (option I). The –R actuators are available in 6 volt and 30, 50 and 100 mm strokes only.

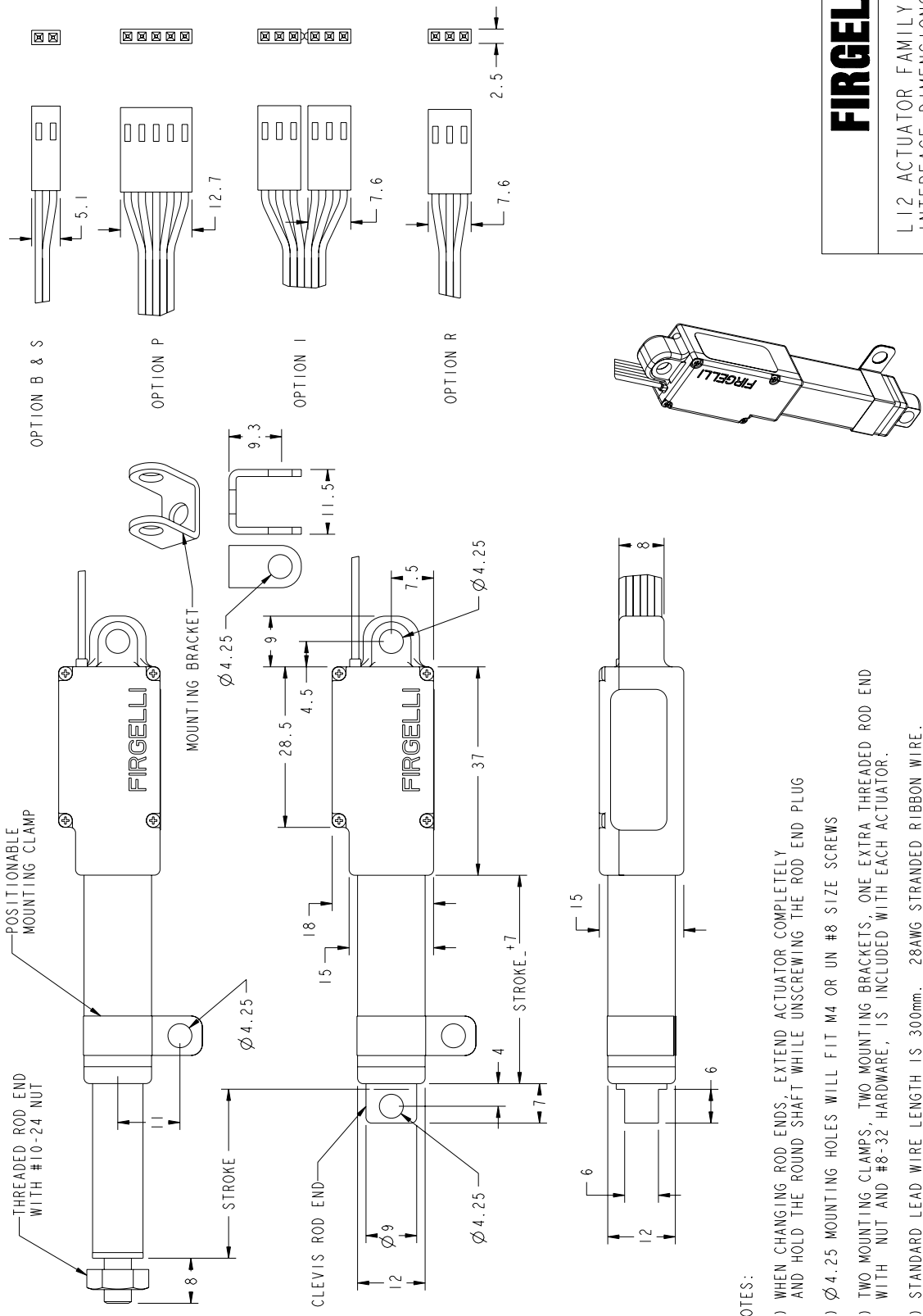

NOTES:

- 1) WHEN CHANGING ROD ENDS, EXTEND ACTUATOR COMPLETELY AND HOLD THE ROUND SHAFT WHILE UNSCREWING THE ROD END PLUG
- 2) Ø4.25 MOUNTING HOLES WILL FIT M4 OR UN #8 SIZE SCREWS
- 3) TWO MOUNTING CLAMPS, TWO MOUNTING BRACKETS, ONE EXTRA THREADED ROD END WITH NUT AND #8-32 HARDWARE, IS INCLUDED WITH EACH ACTUATOR.
- 4) STANDARD LEAD WIRE LENGTH IS 300mm. 28AWG STRANDED RIBBON WIRE. CONNECTORS ARE 2.54mm PITCH FEMALE HEADER CONNECTORS

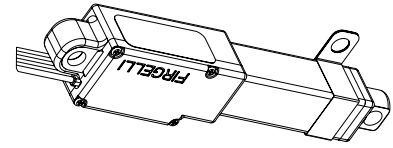

# FIRGELLI

L12 ACTUATOR FAMILY  
INTERFACE DIMENSIONS

SCALE  
3:2