

PGS-5 Gripper

Short Manual

Issue: V1.0

Date: 2021-06-30

Copyright © Shenzhen Yuejiang Technology Co., Ltd. 2021. All rights reserved.

No part of this document may be reproduced or transmitted in any form or by any means without the prior written consent of Yuejiang Technology Co., Ltd..

Disclaimer

To the maximum extent permitted by applicable law, the products described (including its hardware, software, and firmware, etc.) in this document are provided **AS IS**, which may have flaws, errors or faults. Yuejiang makes no warranties of any kind, express or implied, including but not limited to, merchantability, satisfaction of quality, fitness for a particular purpose and non-infringement of third party rights. In no event will Yuejiang be liable for any special, incidental, consequential or indirect damages resulting from the use of our products and documents.

Before using our product, please thoroughly read and understand the contents of this document and related technical documents that are published online, to ensure that the robot is used on the premise of fully understanding the robot and related knowledge. Please use this document with technical guidance from professionals. Even if follow this document or any other related instructions, damages or losses will be happening in the using process, Dobot shall not be considered as a guarantee regarding all security information contained in this document.

The user has the responsibility to make sure following the relevant practical laws and regulations of the country, in order that there is no significant danger in the use of the robot.

If this document is incorrect, please refer to the original document.

Shenzhen Yuejiang Technology Co., Ltd.

Address: Floor 9-10, Building 2, Chongwen Garden, Nanshan iPark, Liuxian Blvd, Nanshan District, Shenzhen, Guangdong Province, China

Website: www.dobot.cc

Contents

1. Specifications	1
2. Description of Control box.....	2
2.1 Control box	2
2.2 Wiring instructions.....	2
3. Installation Instructions	4
3.1 Dimension.....	4
3.2 Installation procedure.....	5

1. Specifications

PGS-5 is a miniature electromagnetic gripper, and the number represents the maximum clamping force. It can only control the opening and closing, as shown in Figure 1.1. The specific parameters are shown in Table 1.1

Table 1.1 PGS-5 specifications

PGS-5 specifications	
Gripping force (per jaw)	3.5-5 N
Opening/closing stroke (both sides)	4 mm
Opening/Closing time	0.03s/0.03 s
Weight	0.2 kg
Noise	< 50 dB
Noise emission	IP40
Communication protocols	I/O
Nominal voltage	24V DC \pm 10%
Nominal current	0.1 A
Peak current	2.5 A



Figure 1.1 PGS-5

2. Description of Control box

2.1 Control box

The clamping claw is equipped with a control box, which is mainly used to control the opening and closing of the electromagnetic claw. As shown in Figure 2.1:



Figure 2.1 Control box

Instructions

- **Indicator:** When the signal is given to the electromagnetic gripper, the indicator light will be on, but if the signal is not given, the indicator light will be off.
- **Dial switch:** Manually control the opening and closing switch of electromagnetic gripper.
- **Gripper interface:** Used to connect the cable of electromagnetic gripper.

Through the dialing control inside the control box, as shown in the red box in Figure 2.2 below. The IO input signal of gripper can be set to NPN or PNP.(Input 0V valid or 24V valid)

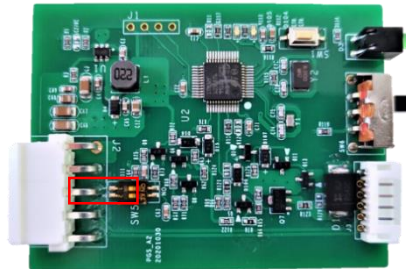

Figure 2.2 Dial switch

Please refer to the following to configure NPN or PNP, as shown in Table 2.1:

Table 2.1 corresponding IO signal table

	Dial 1 (up)	dial 2 (down)
0V valid	1(ON)	0(OFF)
24V valid	0(OFF)	1(ON)

2.2 Wiring instructions

Pgs-5 is controlled by IO, and the electromagnetic claw is directly connected with the control box. Three wires are led out from the control box, respectively, which are 24V, GND and h/l. Se 1 and se 2 currently have no outgoing lines, which can be used to expand the connection sensor of control box or not connect. Three wires are connected for control, respectively, 24V, GND and h/l. The specific connection is as follows:

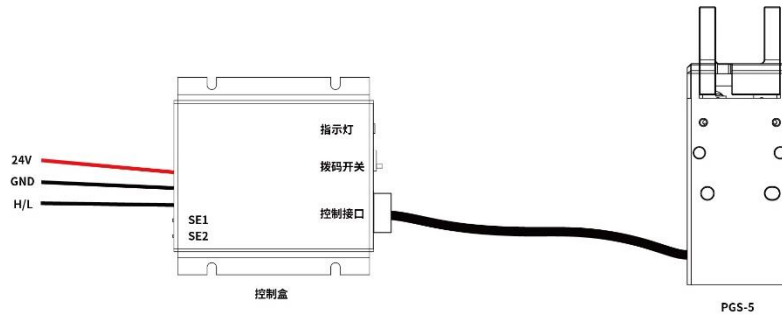

Note

- When using the H / L pin to control the gripper, it is necessary to keep the dial switch in the closed position

The controller (PLC / controller) can control the opening and closing of the electromagnetic claw by outputting the voltage signal corresponding to h / L.

3. Installation Instructions

3.1 Dimension

The specific dimension of PGS-5 gripper is shown in Figure 3.1. The dimension of the control box is shown in Figure 3.2.

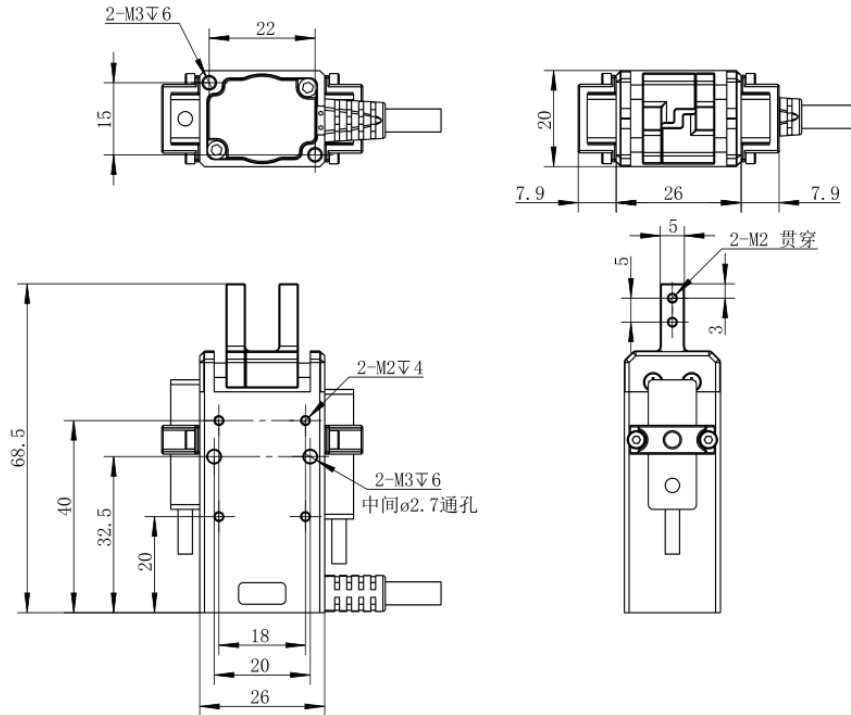

Figure 3.1 Dimension drawing of PGS-5

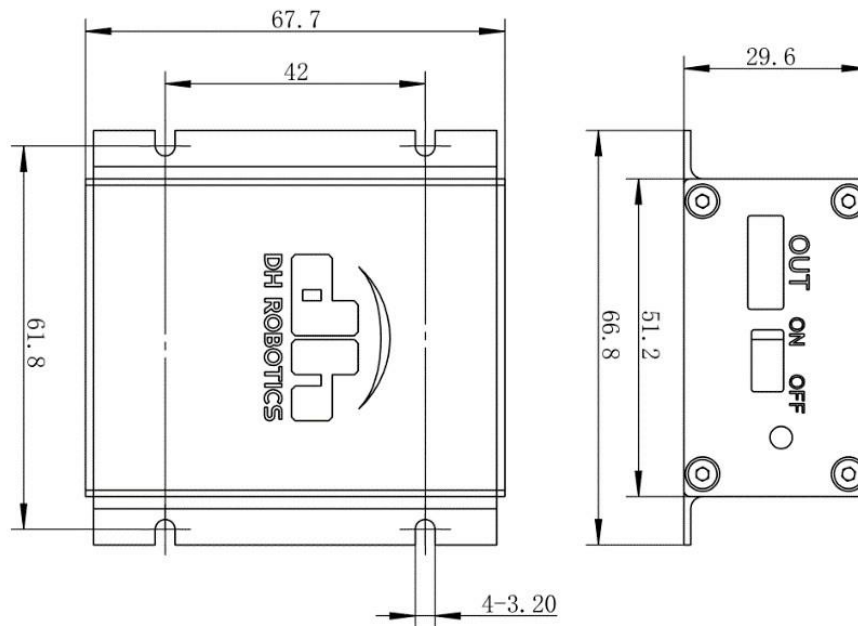

Figure 3.2 Dimension of control box

3.2 Installation procedure

- Step 1** Install the L-shaped gripper to the electromagnetic gripper, and tighten the screw, as shown in Figure 3.3.

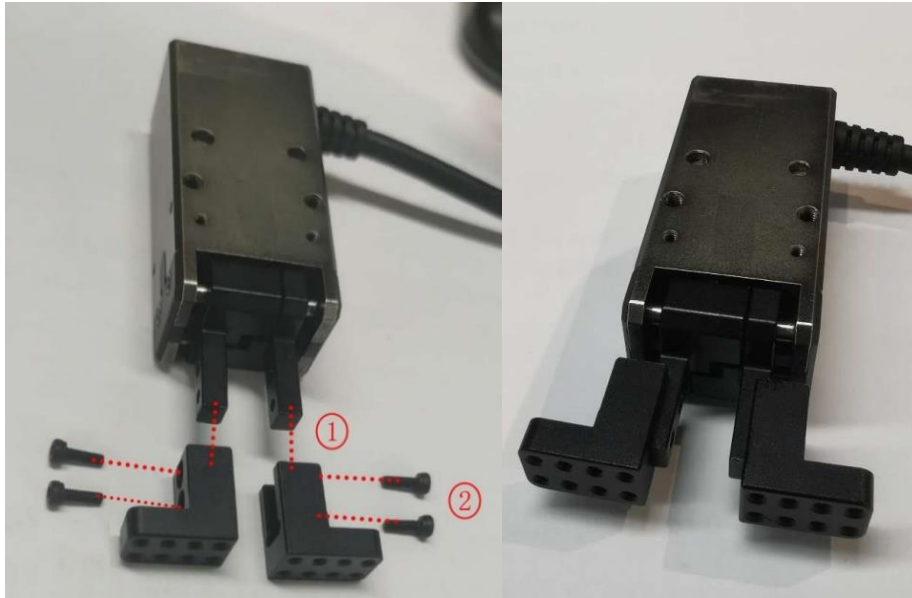

Figure 3.3 Install the L-shaped gripper adapter

- Step 2** Install the square gripper adapter, and tighten the screw, as shown in Figure 3.4. Please adjust the installation position of the square gripper adapter on the L-shaped gripper adapter according to the actual situation. In addition, the protective pads on the left and right sides of the square gripper adapter can be torn off.

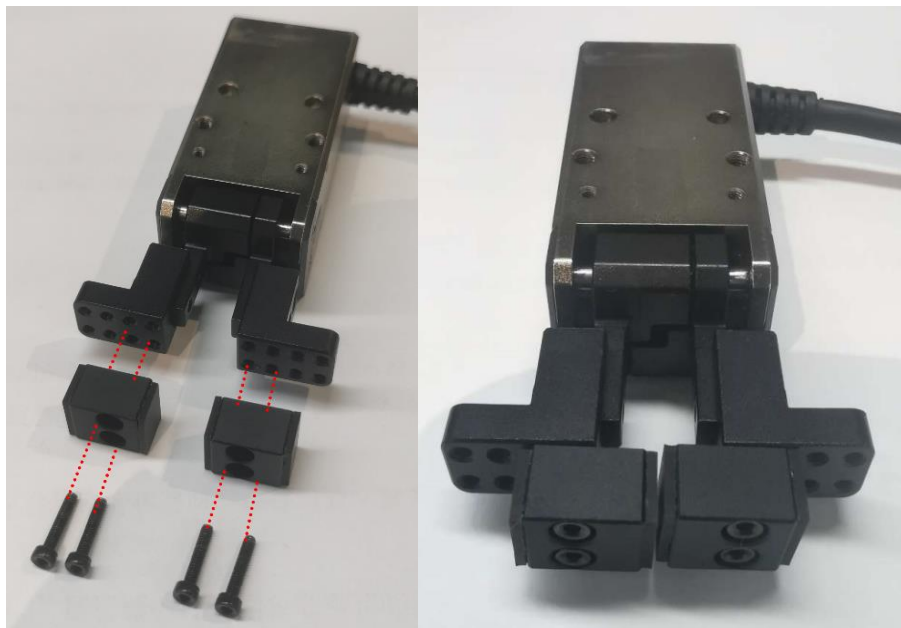

Figure 3.4 Install the square gripper adapter

Step 3 Install the gripper mounting plate, and tighten two screws, as shown in Figure 3.6.



Figure 3.5 Gripper mounting plate



Figure 3.6 Install gripper mounting plate

Step 4 Install the end flange of MG400 (accessory of MG400) to the gripper mounting plate, and tighten four screws, as shown in Figure 3.7.

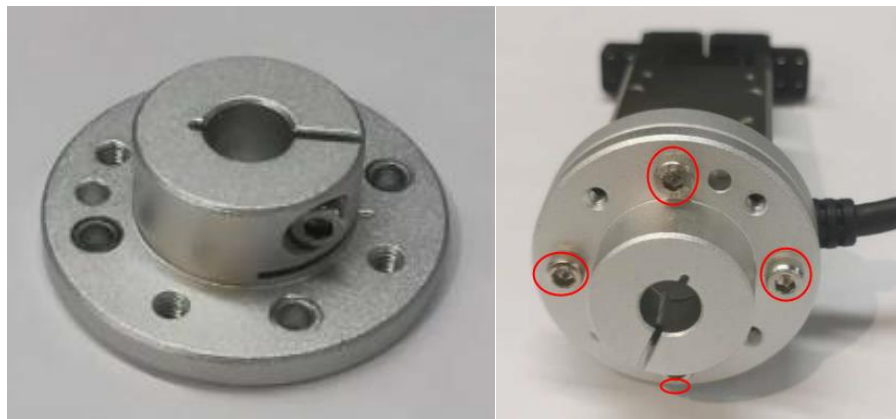

Figure 3.7 Install the end flange of MG400

- Step 5** Install the electromagnetic gripper to MG400 through the end flange of MG400, and tighten the screws on the side of flange.



Figure 3.8 Install electromagnetic gripper

- Step 6** Connect the cable connector of the electromagnetic gripper to the OUT port of control box, as shown in Figure 3.9.



Figure 3.9 Connect electromagnetic gripper to control box

- Step 7** Connect the gripper cable to control box, as shown in Figure 3.10.



Figure 3.10 Connect gripper cable to control box

- Step 8** Connect the gripper cable to MG400, as shown in Figure 3.11. Connect 24V and GND port of gripper cable to 24V and GND port of MG400 respectively. Connect H/L port to any DO port of MG400.



Figure 3.11 Connect gripper cable to MG400