

Introduction

The DFPlayer Mini is a small and low price MP3 module with an simplified output directly to the speaker. The module can be used as a stand alone module with attached battery, speaker and push buttons or used in combination with an Arduino UNO or any other with RX/TX capabilities.

Specification

- supported sampling rates (kHz): 8/11.025/12/16/22.05/24/32/44.1/48
- 24 -bit DAC output, support for dynamic range 90dB , SNR support 85dB
- fully supports FAT16 , FAT32 file system, maximum support 32G of the TF card, support 32G of U disk, 64M bytes NORFLASH
- a variety of control modes, I/O control mode, serial mode, AD button control mode
- advertising sound waiting function, the music can be suspended. when advertising is over in the music continue to play
- audio data sorted by folder, supports up to 100 folders, every folder can hold up to 255 songs
- 30 level adjustable volume, 6 -level EQ adjustable

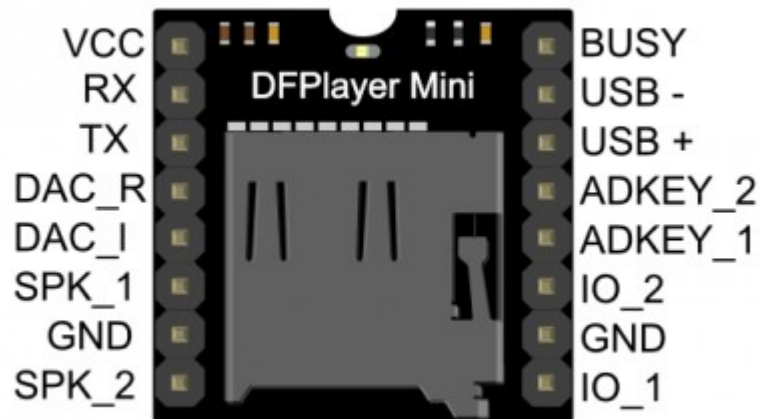

PinOut

Number	Name	Description	Note
1	VCC	Input Voltage	DC3.2-5.0V;Type;DC4.2
2	RX	UART serial input	
3	TX	UART serial output	
4	DAC_R	Audio output right channel	Drive earphone and amplifier
5	DAC_L	Audio output left channel	Drive earphone and amplifier
6	SPK2	Speaker	Drive speaker less than 3W
7	GND	Ground	Power Ground
8	SPK1	Speaker	Drive speaker less than 3W
9	IO1	Trigger port 1	Short pree to play previous(long press to decrease volume)
10	GND	Ground	Power Ground
11	IO2	Trigger port 2	Short pree to play next(long press to increase volume)
12	ADKEY1	AD port 1	Trigger play first segment
13	ADKEY2	AD port 2	Trigger play fifth segment
14	USB+	USB+ DP	USB Port
15	USB-	USB- DM	USB Port
16	Busy	Playing Status	Low means playing/High means no

Information directions

Serial Mode

Support for asynchronous serial communication mode via PC serial sending commands

- Instruction Description

Commands	Function Description	Parameters(16 bit)
0x01	Next	
0x02	Previous	
0x03	Special tracking(NUM)	0-2999
0x04	Increase volume	
0x05	Decrease volume	
0x06	Specify volume	0-30
0x07	Specify EQ 0/1/2/3/4/5	Normal/Pop/Rock/Jazz/Classic/Bass
0x08	Specify playback mode(0/1/2/3)	repeat/folder repeat/single repeat/random
0x09	Specify playback source(0/1/2/3/4)	U/TF/AUX/SLEEP/FLASH
0x0A	Enter into standby-low power loss	
0x0B	Normal working	
0x0C	Reset module	
0x0D	Playback	
0x0E	Pause	
0x0F	Specify folder to playback	1-10 (need to set by user)
0x10	Volume adjust set	[DH=1:Open volume adjust][DL:set volume gain 0-31]
0x11	Repeat play	[1:start repeat play][0:stop play]
0x12	Specify MP3 tracks folder	0-9999
0x13	Commercials	0-9999
0x14	Support 15 folder	See detailed description below
0x15	Stop playback, play background	
0x16	Stop playback	

- Serial Query Cmd

Commands	Function Description	Parameters(16bit)
0x3C	STAY	
0x3D	STAY	
0x3E	STAY	
0x3F	Send initialization parameters	0-0x0F (each bit represent one device of the low-four bits)
0x40	Returns an error, request retransmission	
0x41	Reply	
0x42	Query the current status	
0x43	Query the current volume	
0x44	Query the current status EQ	
0x45	Query the current palyback mode	This version retains this feature
0x46	Query the current software version	This version retains this feature
0x47	Query the total number of TF card files	
0x48	Query the total number of U-disk files	
0x49	Query the total number of FLASH card files	
0x4A	keep on	
0x4B	Queries the current track of TF card	
0x4C	Queries the current track of U-disk	
0x4D	Queries the current track of Flash	

RB-Dfr-562 - DFPlayer Mini MP3 Player

AD KEY Mode

We use the AD module keys, instead of the traditional method of matrix keyboard connection, it is to take advantage of increasingly powerful MCU AD functionality, Our module default configuration 2 AD port, 20 key resistance distribution.

- Refer diagram

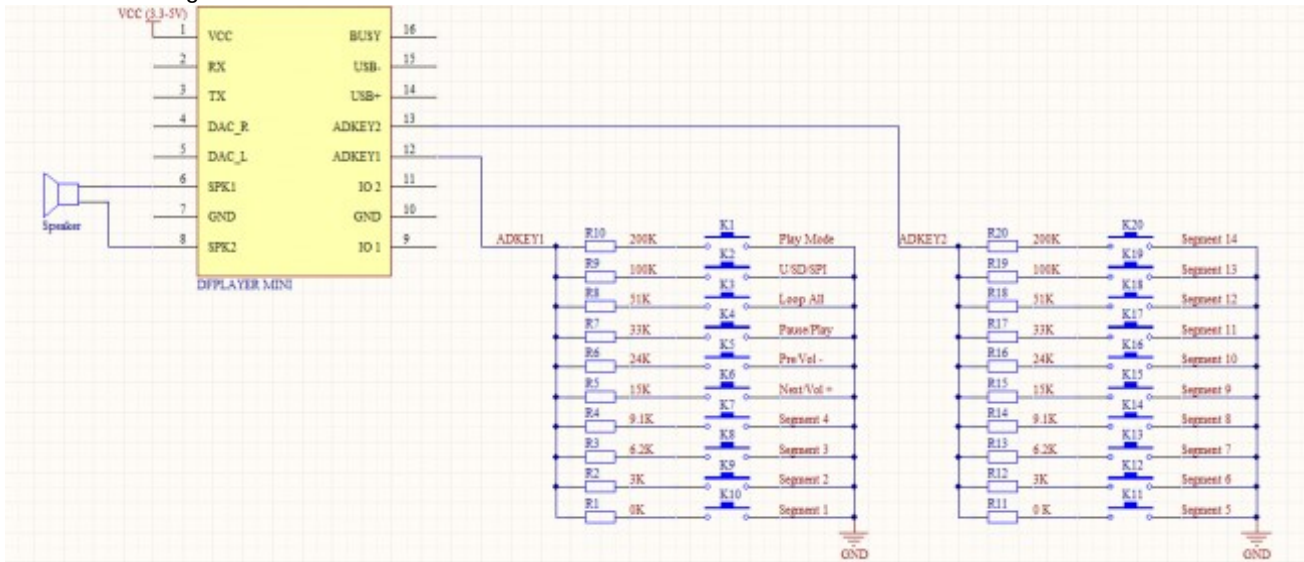

I/O Mode

Here comes the most simple way to use this module.

- Refer diagram

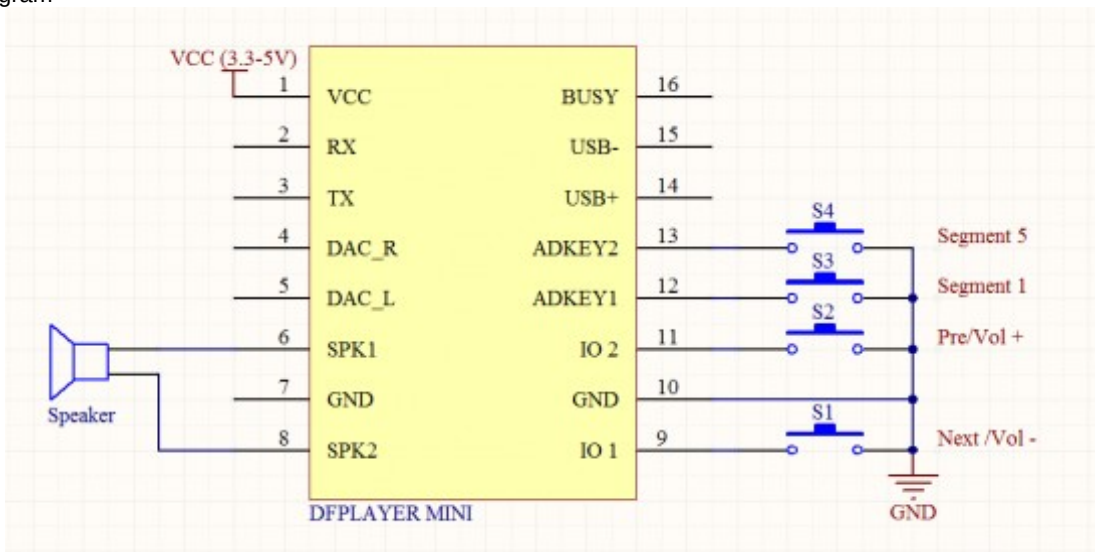

note: short time press means pre/next,and long time press means vol- ,vol +

RB-Dfr-562 - DFPlayer Mini MP3 Player

```
/*
 * Copyright: DFRobot
 * name: DFPlayer_Mini_Mp3 sample code
 * Author: lisper <lisper.li@dfrobot.com>
 * Date: 2014-05-30
 * Description: sample code for DFPlayer Mini, this code is test on Uno
 * note: mp3 file must put into mp3 folder in your tf card
 */

#include <SoftwareSerial.h>
#include <DFPlayer_Mini_Mp3.h>

//
void setup () {
  Serial.begin (9600);
  mp3_set_serial (Serial); //set Serial for DFPlayer-mini mp3 module
  delay(1); // delay 1ms to set volume
  mp3_set_volume (15); // value 0~30
}

//
void loop () {
  mp3_play (1);
  delay (6000);
  mp3_next ();
  delay (6000);
  mp3_prev ();
  delay (6000);
  mp3_play (4);
  delay (6000);
}

/*
  mp3_play (); //start play
  mp3_play (5); //play "mp3/0005.mp3"
  mp3_next (); //play next
  mp3_prev (); //play previous
  mp3_set_volume (uint16_t volume); //0~30
  mp3_set_EQ (); //0~5
  mp3_pause ();
  mp3_stop ();
  void mp3_get_state (); //send get state command
  void mp3_get_volume ();
  void mp3_get_u_sum ();
  void mp3_get_tf_sum ();
  void mp3_get_flash_sum ();
  void mp3_get_tf_current ();
  void mp3_get_u_current ();
  void mp3_get_flash_current ();
  void mp3_single_loop (boolean state); //set single loop
  void mp3_DAC (boolean state);
  void mp3_random_play ();
*/
```

RB-Dfr-562 - DFPlayer Mini MP3 Player

```
/******  
**Wire:  
*Pin10 - player TX;  
*Pin11 - player RX;  
*pin3 - player BUSY  
**Board : Uno  
*By: LEFF  
*****/  
#include <SoftwareSerial.h>  
#include <DFPlayer_Mini_Mp3.h>  
  
SoftwareSerial mySerial(10, 11); // RX, TX  
  
void setup () {  
  Serial.begin (9600);  
  mySerial.begin (9600);  
  mp3_set_serial (mySerial); //set softwareSerial for DFPlayer-mini mp3 module  
  delay(1); // delay 1ms to set volume  
  mp3_set_volume (15); // value 0~30  
}  
void loop () {  
  boolean play_state = digitalRead(3); // connect Pin3 to BUSY pin of player  
  if(play_state == HIGH){  
    mp3_next ();  
  }  
}
```