

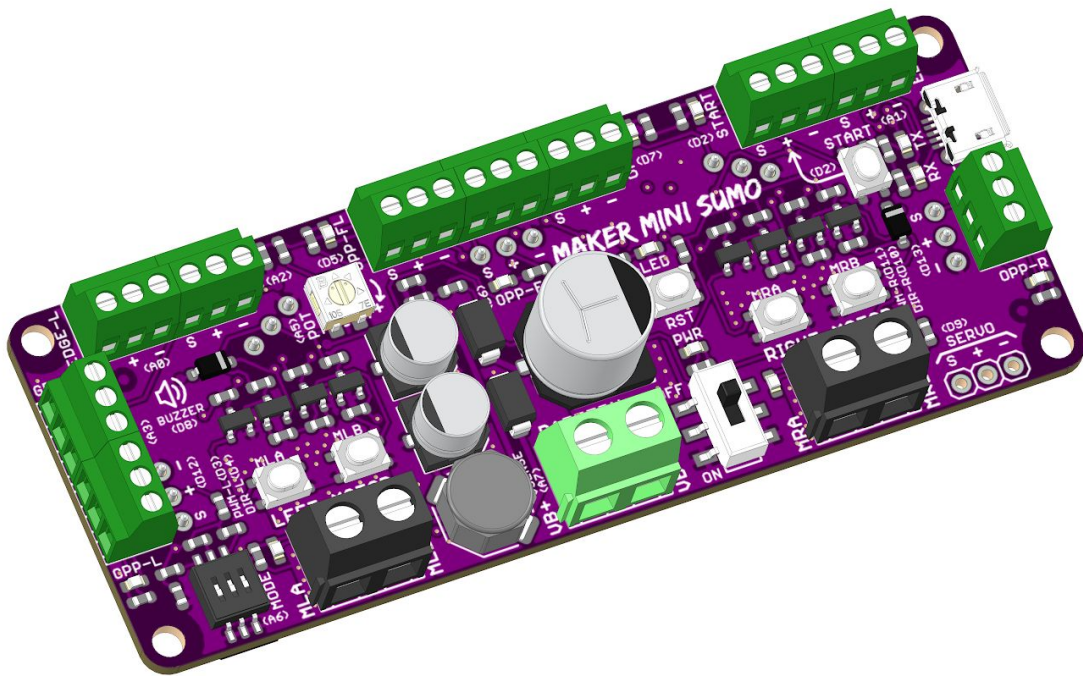

MAKER-MSUMO

Maker Mini Sumo Controller (Arduino Nano/Uno Compatible)



Datasheet

Rev 1.0
November 2019

Information in this publication regarding device applications and the like is intended through suggestion only and may be superseded by updates. It is your responsibility to ensure that your application meets with your specifications. No representation or warranty is given and no liability is assumed by Cytron Technologies Incorporated with respect to the accuracy or use of such information or infringement of patents or other intellectual property rights arising from such use or otherwise. Use of Cytron Technologies's products as critical components in life support system is not authorized except with express written approval by Cytron Technologies. No licenses are conveyed, implicitly or otherwise, under any intellectual property rights.

1. FEATURES

- Arduino Nano/Uno Compatible (Powered by ATMEGA328P).
- Vin: 7V - 18V
- Reverse polarity protection on Vin.
- Vibration proof on/off switch with MOSFET latching circuit.
- Battery voltage can be read programmatically.
- Switching regulator for +5V reduce heat and increase efficiency.
- Motor: 3A continuous, 6A peak
- Test buttons and status LED for motors.
- 5 x Opponent Sensors Input (Digital) with LED state indicator.
- 2 x Edge Sensors Input (Analog/Digital).
- 2 x General Purpose Input Output (Analog/Digital Input or Digital Output).
- 1 x Start Module Input (Digital), with LED and onboard start button.
- 1 x Servo Output.
- 1 x Programmable LED.
- 1 x Onboard Potentiometer.
- 1 x Mode Selection DIP Switch (3 Ways).
- 1 x Piezo Buzzer (Able to play melody).

2. BOARD LAYOUT & FUNCTION

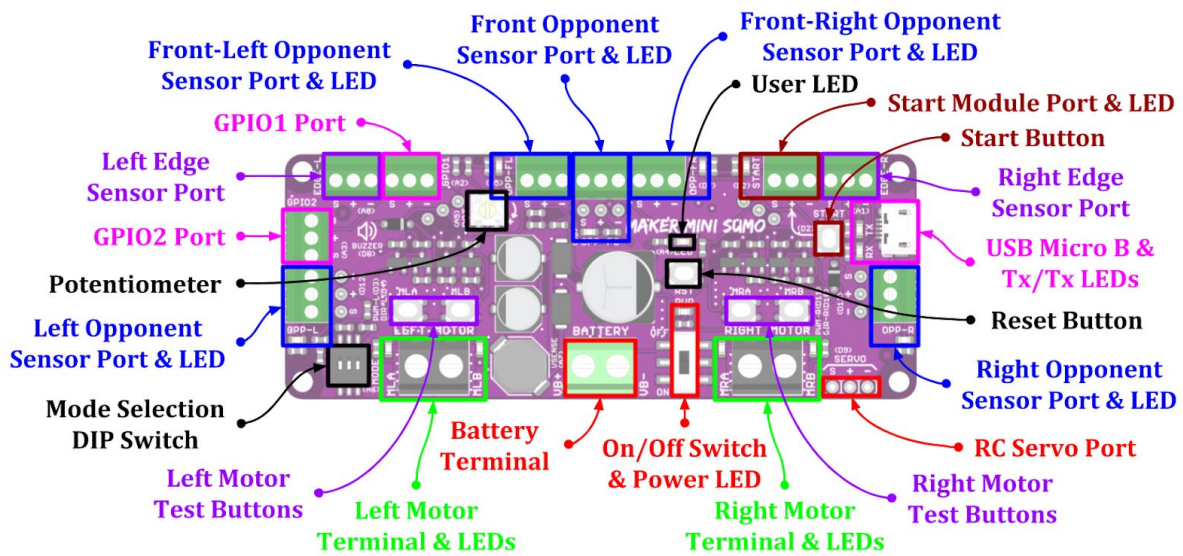

Figure 1: MAKER-MSUMO Board Functions (Top)

Function	Description
Battery Terminal	Connect to battery. <ul style="list-style-type: none"> • VB+ : Positive • VB- : Negative/Ground VB+ is connected to analog input via voltage divider and the voltage can be read by the microcontroller.
On/Off Switch	Turn on/off the power to the board.
Power LED	Turn on when power up.
Motor Terminals	Connect to motors. Motor direction is dependent on the polarity.
Motor Status LEDs	Turn on when the motor is running. <ul style="list-style-type: none"> • MLA / MRA : Forward* • MLB / MRB : Backward*
Motor Test Buttons	Test the functionality of the motor driver without programming. Motor will run at full speed. <ul style="list-style-type: none"> • MLA / MRA : Forward* • MLB / MRB : Backward*
Opponent Sensor Ports	Connect to opponent sensors (Or any other digital inputs). Internally pulled up to +5V. <ul style="list-style-type: none"> • S : Digital Input Signal. • + : DC +5V Output. • - : Ground.
Opponent Sensor Status LEDs	Indicate the status of opponent sensor. Turn on when the signal is low (Active Low). For MAKER-OBJECT, LEDs turn on when opponent is detected.

Edge Sensor Ports	Connect to edge/line sensors (Or any other analog inputs). <ul style="list-style-type: none"> ● S : Analog Input Signal. ● + : DC +5V Output. ● - : Ground.
GPIO1 / GPIO2 Ports	General Purpose Input/Output. Can be used as a digital input/output or analog input. <ul style="list-style-type: none"> ● S : Digital Input/Output or Analog Input Signal. ● + : DC +5V Output. ● - : Ground.
RC Servo Port	Connect to RC servo. <ul style="list-style-type: none"> ● S : Signal ● + : +5V. ● - : Ground.
USB Micro B Connector	Used to upload Arduino program from PC. Can be used for debugging purpose too (Serial Monitor).
Tx/Rx LEDs	Turn on when data is transmitted/received via the serial port. <ul style="list-style-type: none"> ● Tx: Data transmitted from the microcontroller. ● Rx: Data received by the microcontroller.
Reset Button	Press to reset the microcontroller.
Start Button	Programmable button. Usually used as start button.
Start Module Port	Connected in parallel with the start button. Can be used to connect external start button or IR start module. Signal pin is internally pulled high to +5V. <ul style="list-style-type: none"> ● S : Digital Input Signal. ● + : DC +5V Output. ● - : Ground.
Start LED	Turn on when the start button is pressed or the start module signal is low (Active Low).
User LED	Programmable LED. Can be turned on/off from the user program.
Potentiometer	Connected internally to analog input. Can be used to fine tune the robot speed, sensor threshold, etc...
Mode Selection DIP Switch	3-Ways DIP switch provides up to 8 configuration. Can be used to select different tactic/mode for competition.

Table 1: MAKER-MSUMO Board Functions (Top)

* Actual motor direction is dependent on the motor connection.
 Swapping the connection (MxA & MxB) will reverse the direction.

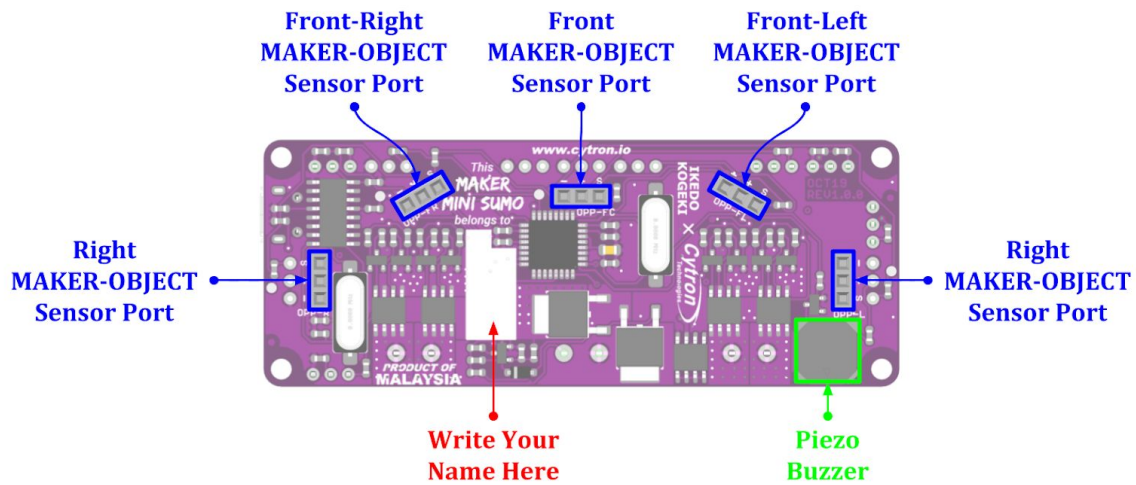

Figure 2: MAKER-MSUMO Board Functions (Bottom)

Function	Description
MAKER-OBJECT Sensor Ports	Connect to MAKER-OBJECT opponent sensors. Connected in parallel with top layer opponent sensor ports. Internally pulled up to +5V. <ul style="list-style-type: none"> ● S : Digital Input Signal. ● + : DC +5V Output. ● - : Ground.
Piezo Buzzer	Programmable piezo buzzer. Can be used to play tone or melody.

Table 2: MAKER-MSUMO Board Functions (Bottom)

PWM-L/PWM-R	DIR-L/DIR-R	MLA/MRA	MLB/MRB	Motor
Low	X (Don't Care)	Low	Low	Brake
High	Low	High	Low	Forward*
High	High	Low	High	Backward*

Table 3: Input Truth Table

* Actual motor direction is depending on the motor connection.
 Swapping the connection (MxA & MxB) will reverse the direction.

3. ARDUINO PIN MAPPING

All the pins of ATMEGA328P on MAKER-MSUMO are already pre-defined in the [CytronMakerSumo Library](#). Please refer to the GitHub page on how to install the library.

Port		Constant Defined in Library	Arduino Pin
User LED		LED	A4
Piezo Buzzer		BUZZER	D8
Potentiometer		POT	A5
Mode Selection DIP Switch		MODE	A6
Battery Voltage Sensor (Voltage Divider)		VBATT	A7
Left Motor	PWM	PWM_L	D3
	Direction	DIR_L	D4
Right Motor	PWM	PWM_R	D11
	Direction	DIR_R	D10
RC Servo		SERVO	D9
Edge/Border Sensor	Left	EDGE_L	A0
	Right	EDGE_R	A1
Start Button / Start Module		START	D2
Opponent Sensor	Left	OPP_L	D12
	Right	OPP_R	D13
	Front-Center	OPP_FC	D6
	Front-Left	OPP_FL	D5
	Front-Right	OPP_FR	D7
General Purpose Input/Output (GPIO)	GPIO 1	GPIO1	A2
	GPIO 2	GPIO2	A3

4. SPECIFICATIONS

No	Parameters	Min	Max	Unit	
1	Power Input Voltage (Vin)	7.0	18.0	VDC	
2	Maximum Motor Current (Per Channel)	Continuous	-	3.0	A
		Peak (< 5 seconds)	-	6.0	A
3	Motor PWM Frequency	DC	20	KHz	
4	Digital Input Voltage	Low Level	0	0.5	V
		High Level	1.7	5.0	V
5	Analog Input Voltage	0	5.0	V	
5	DC +5V Output Maximum Current (Total)	-	500	mA	

Table 3: MAKER-MSUMO Absolute Maximum Ratings

5. DIMENSION

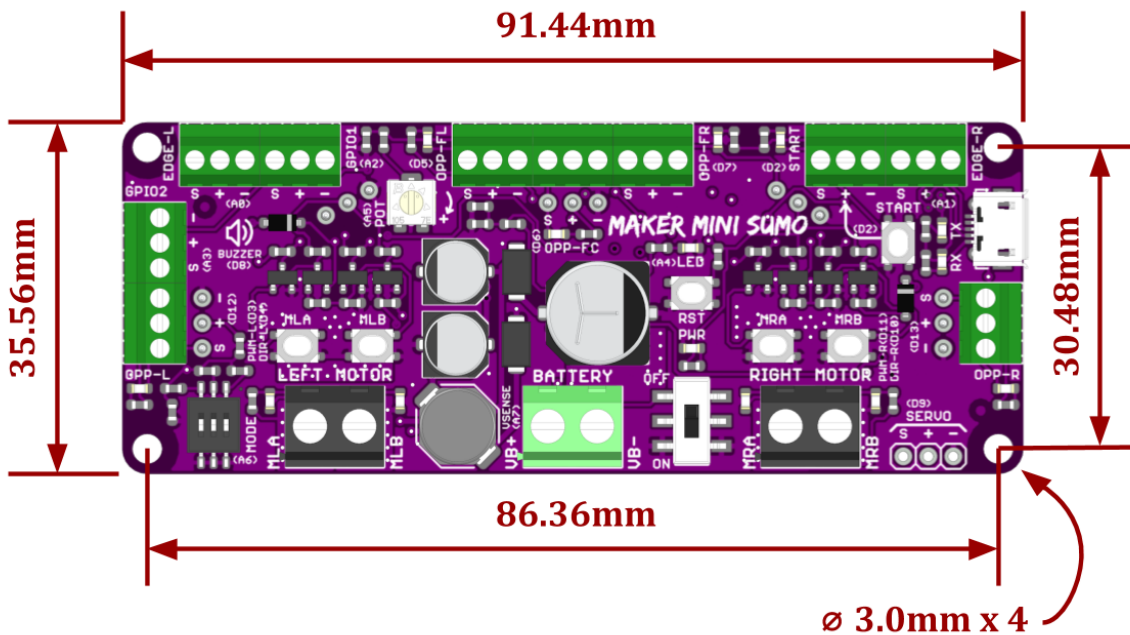

Figure 3: MAKER-MSUMO Dimension

Prepared by:

Cytron Technologies Sdn Bhd

www.cytron.io

No. 1, Lorong Industri Impian 1,
Taman Industri Impian,
14000 Bukit Mertajam,
Penang, Malaysia.

Tel: +604 - 548 0668

Fax: +604 - 548 0669

Email:

support@cytron.io

sales@cytron.io