

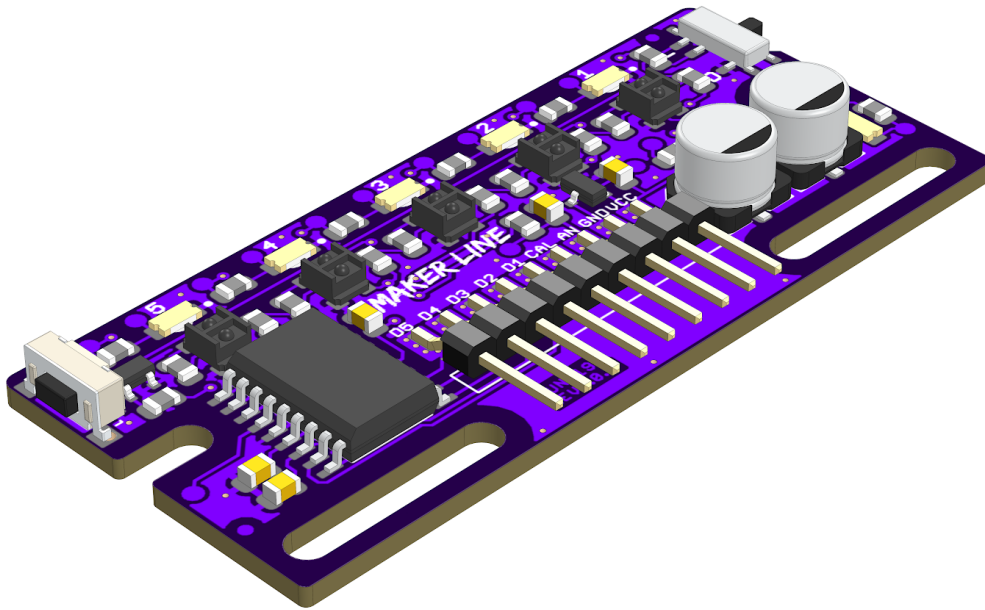

MAKER-LINE

Simplifying Line Sensor for Beginner



Datasheet

Rev 1.0
July 2019

Information in this publication regarding device applications and the like is intended through suggestion only and may be superseded by updates. It is your responsibility to ensure that your application meets with your specifications. No representation or warranty is given and no liability is assumed by Cytron Technologies Incorporated with respect to the accuracy or use of such information or infringement of patents or other intellectual property rights arising from such use or otherwise. Use of Cytron Technologies's products as critical components in life support system is not authorized except with express written approval by Cytron Technologies. No licenses are conveyed, implicitly or otherwise, under any intellectual property rights.

1. BOARD LAYOUT & FUNCTION

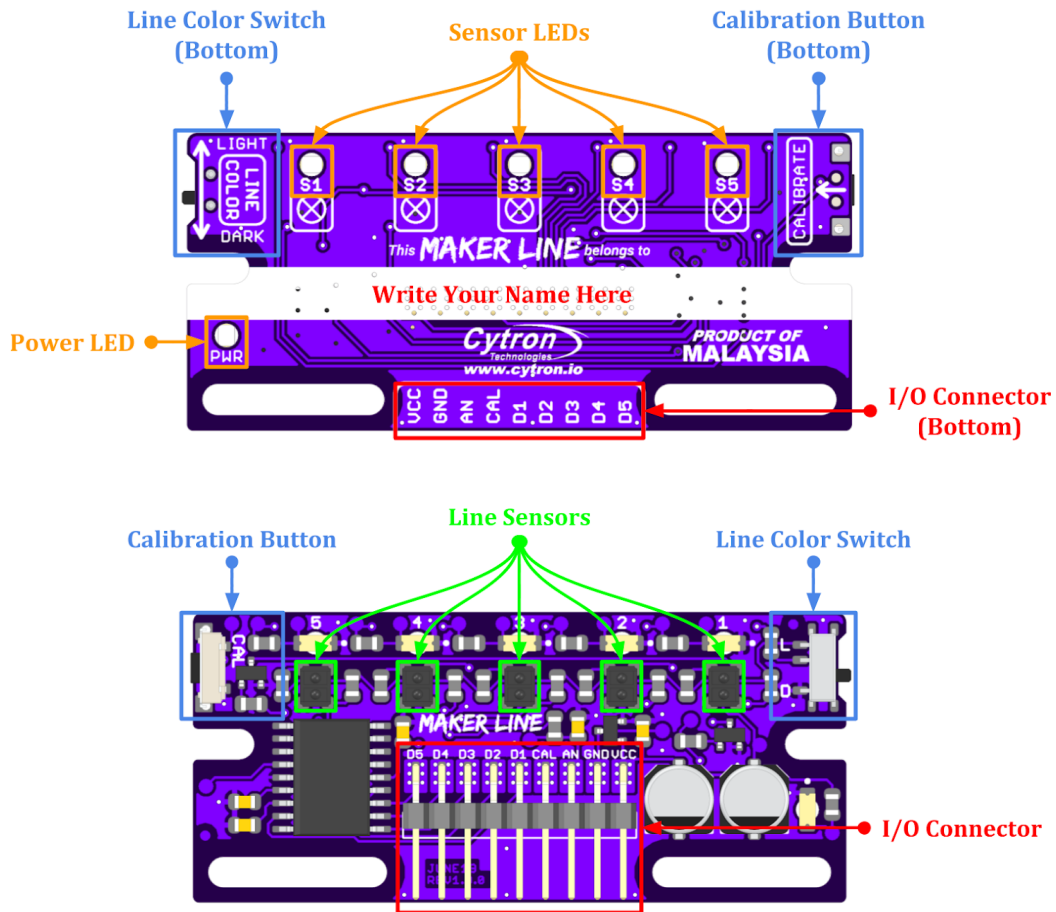

Figure 1: MAKER-LINE Board Functions

Function	Description
I/O Connector	Input/Output Connector <ul style="list-style-type: none"> ● VCC : Power input for the Maker Line.* ● GND : Ground.* ● AN : Analog output. The voltage represents line position. ● CAL : Short to GND to enter/exit sensor calibration mode. ● D1 : Sensor 1 digital output. High when line is detected. ● D2 : Sensor 2 digital output. High when line is detected. ● D3 : Sensor 3 digital output. High when line is detected. ● D4 : Sensor 4 digital output. High when line is detected. ● D5 : Sensor 5 digital output. High when line is detected. * VCC and GND has reverse polarity protection.
Line Sensors (S1 - S5)	Infrared sensors for line detection
Power LED	Turn on when power up.
Sensor LEDs (S1 - S5)	Turn on when line is detected by the sensor.
Line Color Switch	Select the line colour (Light/Dark).
Calibration Button	Press and hold for 2 seconds to enter sensors calibration mode. Press again to exit calibration mode when done.

Table 1: MAKER-LINE Board Functions

2. SPECIFICATIONS

No	Parameters	Min	Max	Unit	
1	VCC Voltage	3.0	5.5	V	
2	Digital Output Voltage (D1 - D5)	Low Level	0	0.5	V
		High Level	0.7*VCC	VCC	V
3	Analog Output Voltage (AN)	0	VCC	V	
4	Sensing Distance* (VCC = 5V, Black line on white surface)	4	40	mm	
5	Sensor Refresh Rate	200		Hz	
6	Recommended Line Width	13	30	mm	

Table 2: MAKER-LINE Absolute Maximum Ratings

* Sensing distance may reduce if VCC is less than 5V or the line-background contrast is low.

3. DIMENSION

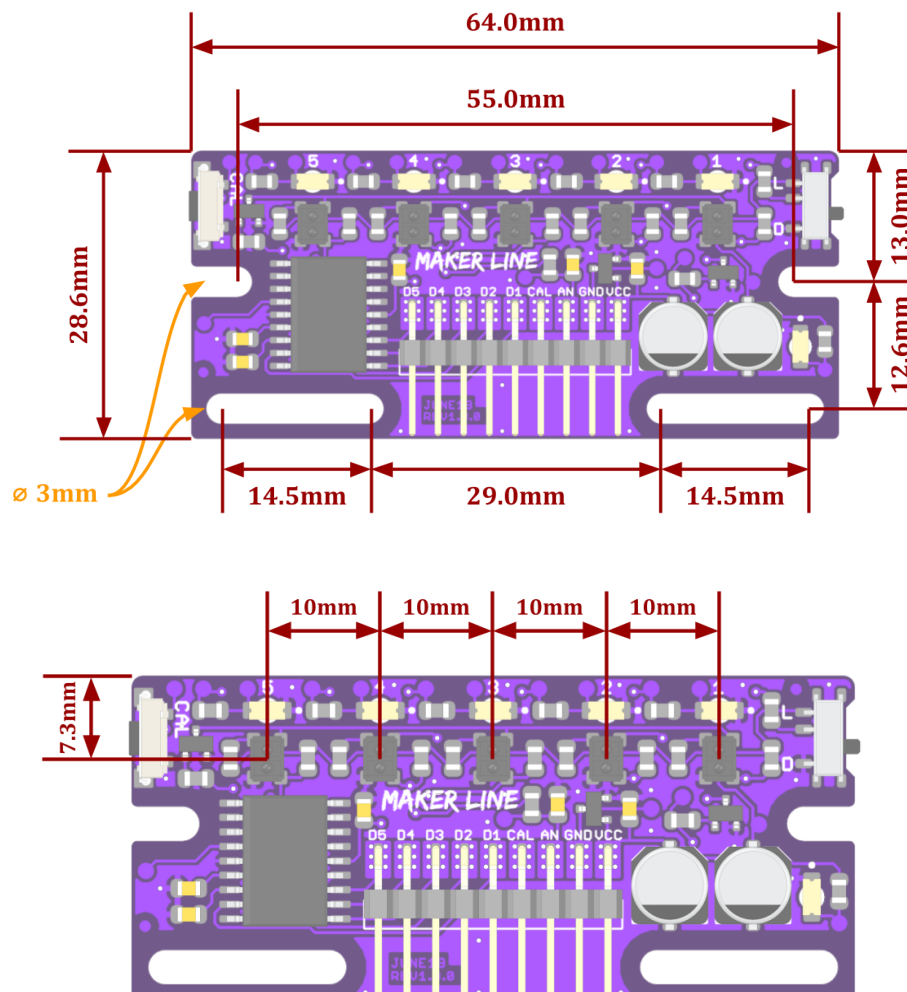

Figure 2: MAKER-LINE Dimension

4. INTERFACE: Digital Output

Digital Output

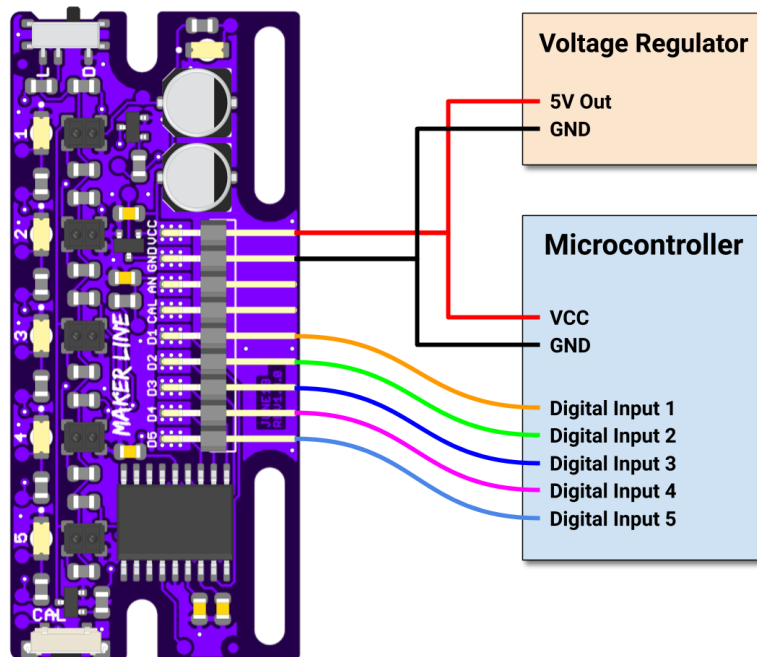

Figure 3: Connection Diagram for Digital Output

Line Color Switch	Sensor (Sx) *	LED (Sx) *	Digital Output (Dx) *
Light	Light Surface	On	High
Light	Dark Surface	Off	Low
Dark	Light Surface	Off	Low
Dark	Dark Surface	On	High

Table 3: Digital Output Truth Table

* Sx = S1, S2, S3, S4 or S5

* Dx = D1, D2, D3, D4 or D5

5. INTERFACE: Analog Output

Analog Output

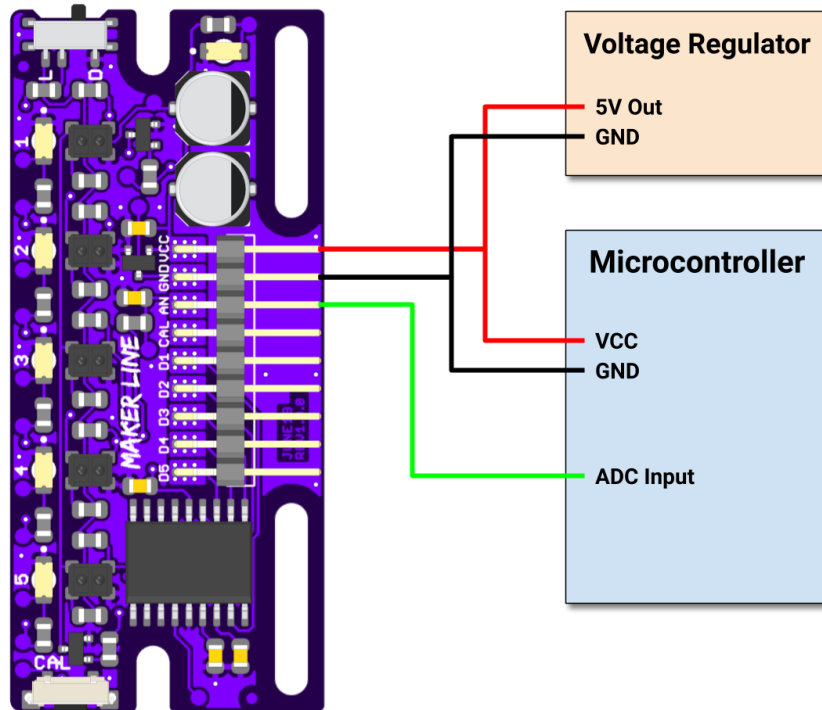

Figure 4: Connection Diagram for Analog Output

Line Position	Line Not Found	Left	←	→	Center	←	→	Right	Cross Detected (All Sensors On)
Analog Output	Less Than $0.1 * V_{cc}$	$0.1 * V_{cc}$	←	→	$V_{cc} / 2$	←	→	$0.9 * V_{cc}$	More Than $0.9 * V_{cc}$
Analog Output ($V_{cc} = 3.3V$)	0 - 0.33V	0.33V	←	→	1.65V	←	→	2.97V	2.97 - 3.3V
Analog Output ($V_{cc} = 5V$)	0 - 0.5V	0.5V	←	→	2.5V	←	→	4.5V	4.5 - 5V

Table 4: Analog Output Voltage Corresponding to Line Position

6. SENSOR CALIBRATION

Before start using the MAKER-LINE, the sensors need to be calibrated so that it can differentiate between the line and the background. Calibration data will be saved in the EEPROM and it will be retained even after the MAKER-LINE is power off.

Calibration only needs to be carried out once unless the sensor height, line or background color has changed. To perform sensor calibration, follow the steps below:

1. Mount the MAKER-LINE to the robot exactly the way it will be used and power up the sensor.
2. Select the line color using the slide switch.
3. Press and hold the calibrate button for more than 2 seconds. The LEDs will show the progress while waiting.
4. All 5 LEDs will start blinking after entering calibration mode. The push button can be released now.
5. Swap the MAKER-LINE across the line so that all sensors have been exposed to the line.
6. Press the calibrate button again to exit calibration mode. The LEDs will show the calibration result.
 - Running Light : Calibration is successful.
 - Fast Blink : Calibration failed. Contrast between line and background is too low or the sensor is too high from the surface.

Now the MAKER-LINE is calibrated and is ready to use.

Warning: *Please make sure the distance of MAKER-LINE from the surface does not change during the calibration process.*



[Check out this video on how to calibrate the sensor.](#)

Prepared by:

Cytron Technologies Sdn Bhd

www.cytron.io

No. 1, Lorong Industri Impian 1,
Taman Industri Impian,
14000 Bukit Mertajam,
Penang, Malaysia.

Tel: +604 - 548 0668

Fax: +604 - 548 0669

Email:

support@cytron.io

sales@cytron.io