

T200 Thruster Documentation

Table of Contents

[Table of Contents](#)

[Introduction](#)

[Safety](#)

[Quick Start](#)

[Important Notes](#)

[T200 Thruster Specifications](#)

[Specification Table](#)

[Performance Charts](#)

[Dimensions](#)

[T200 Thruster \(without BlueESC\)](#)

[T200 Thruster with BlueESC](#)

[Installation](#)

[Mounting Options](#)

[Electrical Connections](#)

[Connecting to an External ESC](#)

[Connecting the BlueESC](#)

[How to Cut and Strip the Cable](#)

[Operation](#)

[Clicking Noise](#)

[Care and Maintenance](#)

[Normal Care](#)

[Troubleshooting](#)

[Details](#)

[Comparison to T100](#)

[Test Results](#)

[Quality Control](#)

[Painting the Thruster](#)

Introduction

The T200 Thruster is a low-cost high performance thruster for marine robotics. It was originally launched in 2014 through a Kickstarter campaign.

Safety

Always practice caution when you're working with electricity in water and with the spinning blades of the propeller. Keep body parts away from the thruster inlet and outlet to avoid injury.

Quick Start

1. Connect motor wires to ESC and connect the ESC to power and a signal.
2. Send a signal and the thruster will start spinning. That's it.

Important Notes

Do not operate the thruster for extended periods out of water. The bearings are lubricated by the water and vibration and noise will be greater when dry.

The thruster can handle saltwater and sandy environments pretty well, but it does not get along with seaweed. Avoid sucking seaweed into the thruster to avoid damage.

A slight clicking noise is normal, especially when operated dry. It is caused by slight movement of the shaft in the plastic bearings.

T200 Thruster Specifications

Specification Table

Performance

Maximum Forward Thrust @ 16V	5.1 kgf	11.2 lbf
Maximum Reverse Thrust @ 16V	4.1 kgf	9.0 lbf
Maximum Forward Thrust @ 12V	3.55 kgf	7.8 lbf
Maximum Reverse Thrust @ 12V	3.0 kgf	6.6 lbf
Minimum Thrust	0.01 kgf	0.02 lbf
Rotational Speed	300-3800 rev/min	

Electrical

Operating Voltage	6-20 volts	
Max Current	25 Amps	
Max Power	350 Watts	
Phase Resistance	0.18 +/- 0.01 Ohms	
Phase Inductance (@ 1 kHz)	0.077 +/- 0.008 mH	

Physical

Length (without BlueESC)	113 mm	4.45 in
Length (with BlueESC)	131 mm	5.16 in
Diameter	100 mm	3.9 in
Weight in Air (with 1m cable)(without BlueESC)	0.76 lb	344 g
Weight in Air (with 1m cable)(with BlueESC)	0.93 lb	422 g
Weight in Water (with 1m cable)(without BlueESC)	0.34 lb	156 g
Weight in Water (with 1m cable)(with BlueESC)	0.46 lb	210 g
Propeller Diameter	76 mm	3.0 in
Mounting Hole Threads	M3 x 0.5	
Mounting Hole Spacing	19 mm	0.75 in

Cable Length	1.0 m	39 in
Cable Diameter	6.3 mm	0.25 in

Performance Charts

T200 Thruster: Thrust vs. PWM Input to ESC

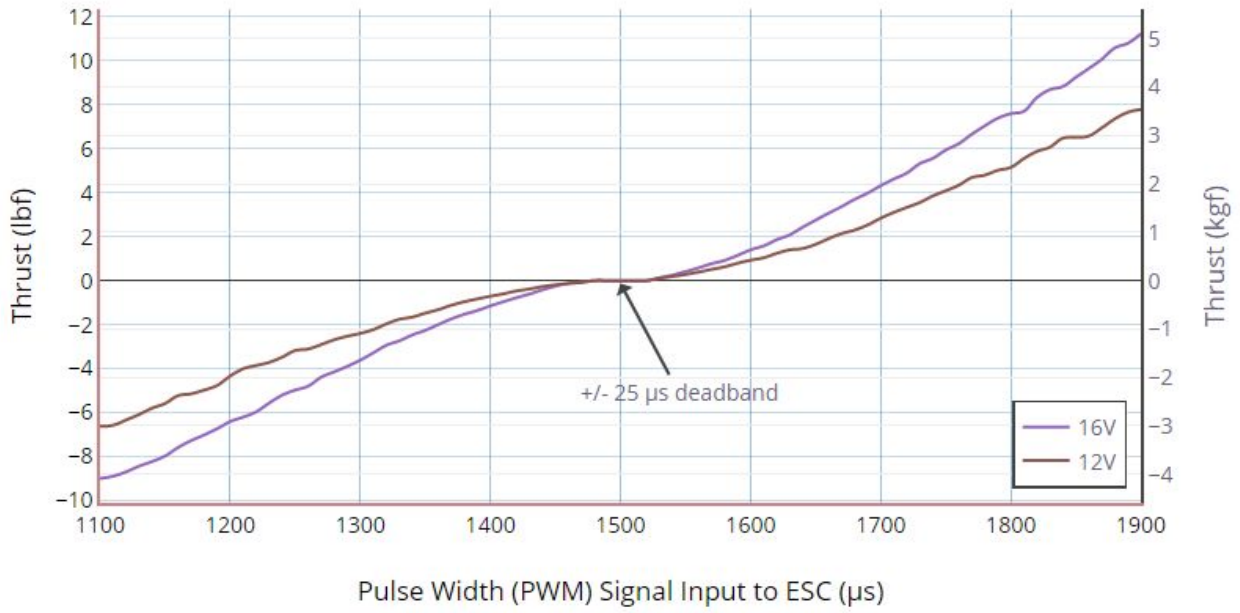

T200 Thruster: Power vs. PWM Input to ESC

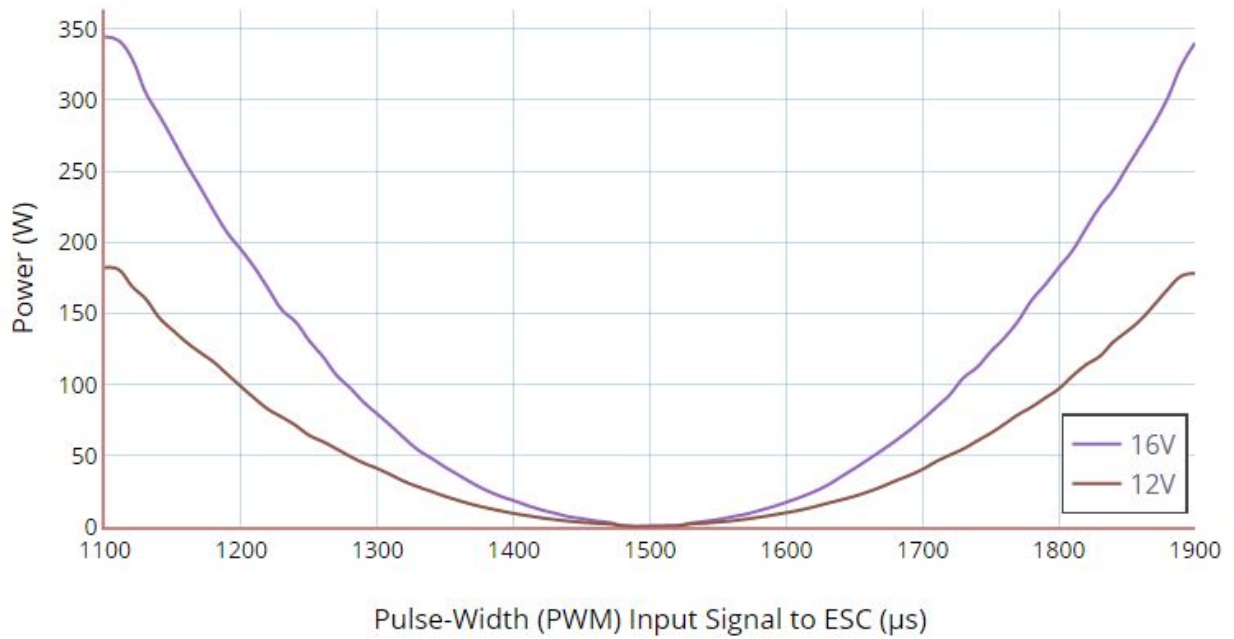

T200 Thruster: Current vs. PWM Input to ESC

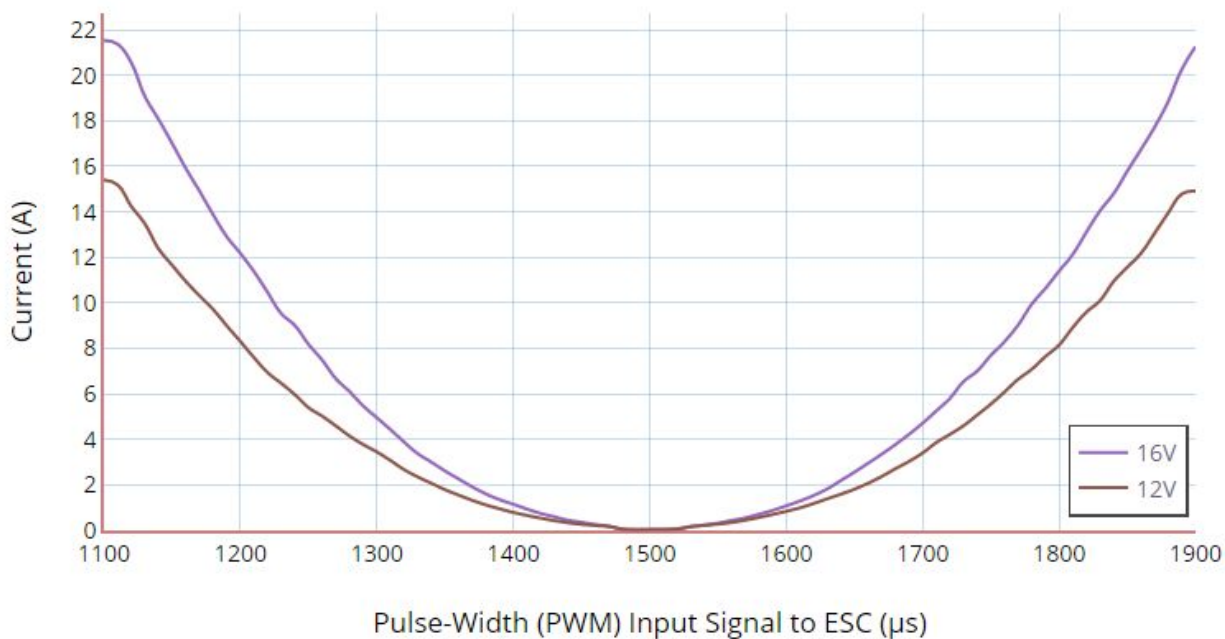

T200 Thruster: Power vs. Thrust

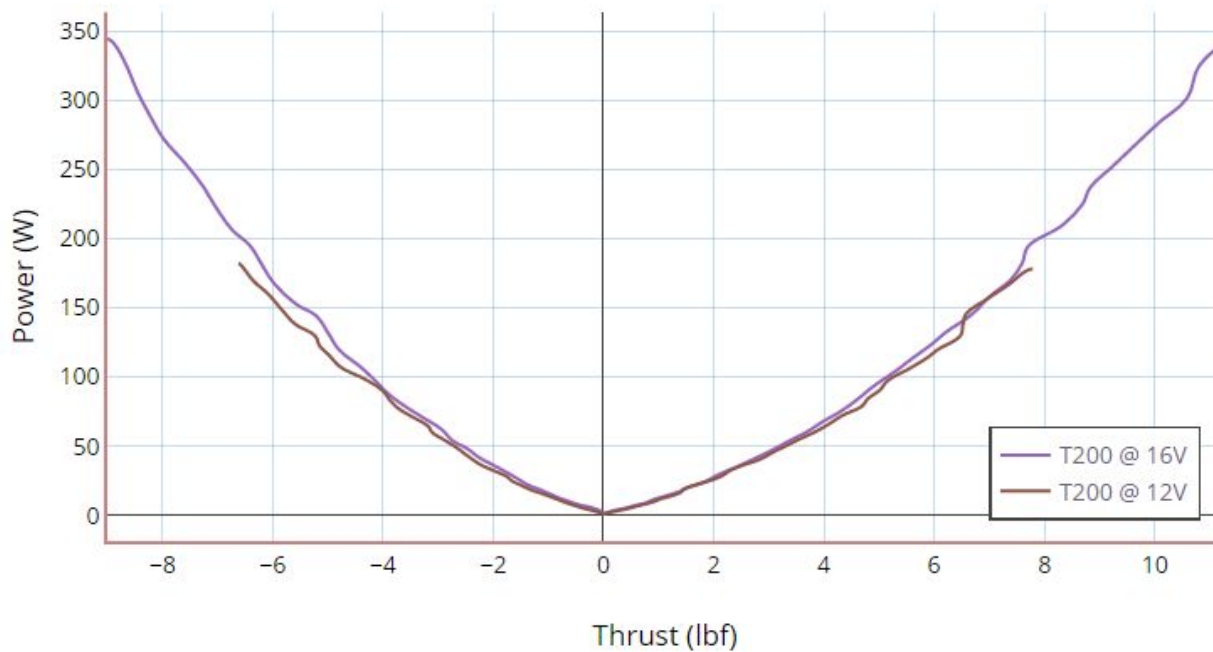

T200 Thruster: Efficiency vs. PWM Input to ESC

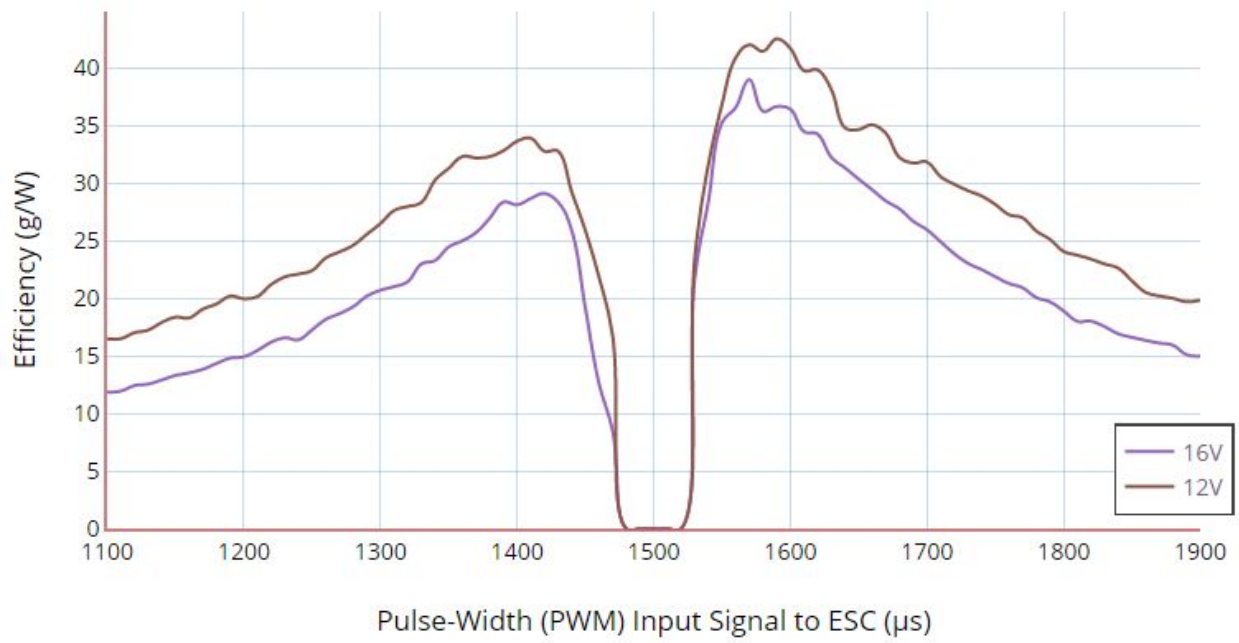

Dimensions

T200 Thruster (without BlueESC)

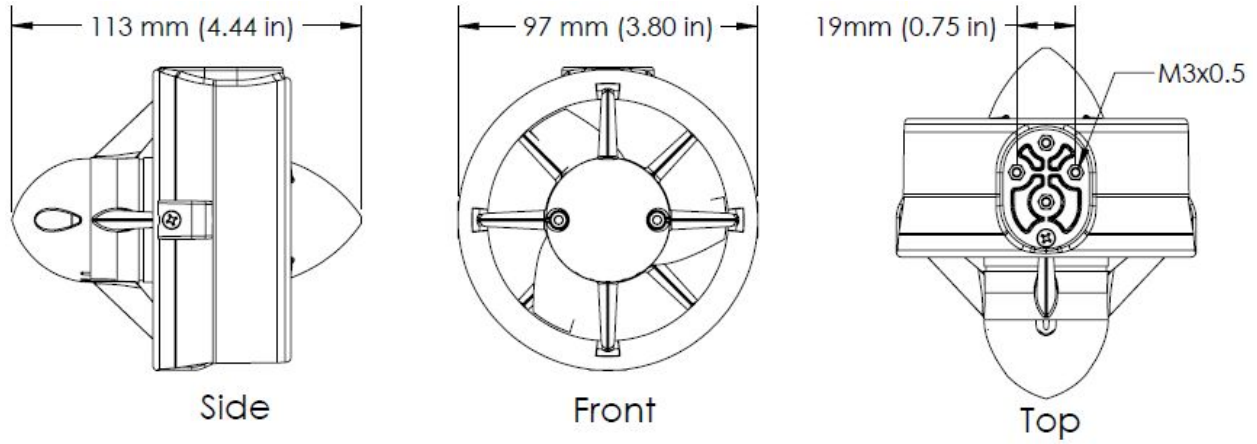

T200 Thruster with BlueESC

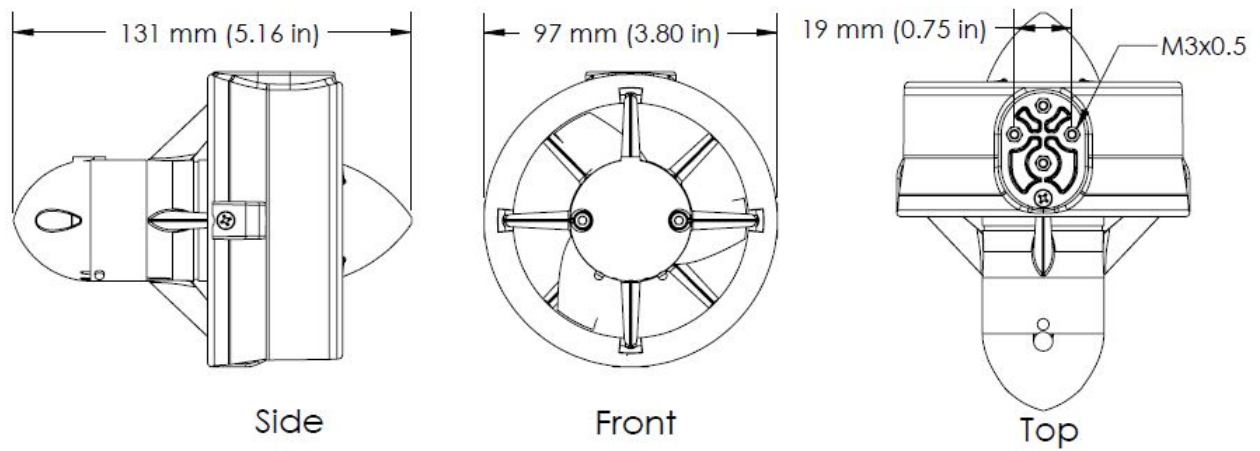

Installation

The T200 Thruster is easy to install in many different applications. It was designed with versatile mounting options for a variety of different applications. It includes a counter-rotating set of propellers. Check out the tutorial on how to change the propeller.

Mounting Options

The T200 Thruster has several mounting options. The nozzle has four mounting holes that can be used to secure directly to vehicle.

Occasionally, these holes may not be convenient or it may be difficult to secure the screws. In this case, the mounting bracket may be a better option. The mounting bracket is secured to the thruster through the four screw holes. It can be mounted in two different orientation as shown below.



Thruster with bracket in front/back orientation



Thruster with bracket in side to side orientation

The mounting bracket also includes a guide hole that can be drilled out with a 1/4" (6.5mm) drill bit to allow the wire to pass directly through the bracket.

Which mounting option you choose depends on your application.

Electrical Connections

Connecting to an External ESC

The thruster has a cable containing three wires. These three wires must be connected to the three motor wires on the electronic speed controller (ESC). The order does not matter, but if the motor direction is the reverse of what is desired, switch two of the wires.

The three wires in the cable (green, white, blue) are always connected to the same motor phases, so connecting the colors in a consistent fashion will result in all motors rotating in the same direction.

Connecting the BlueESC

The BlueESC must be pre-installed on the T100 Thruster.

How to Cut and Strip the Cable

The thruster comes with a tough urethane-jacketed cable. This is great for use underwater, but it can be a little difficult to remove the jacket from the wires if you want to cut the cable to a shorter length. During production, we use a thermal wire strippers, but the jacket can also be removed with a razor blade or hobby knife.

Operation

The thruster requires a brushless electronic speed controller (ESC). If you are using the [BlueRobotics BasicESC \[RB-Blu-125\]](#) or BlueESC, please see the appropriate product page for instructions.

Important: Do not operate the thruster for extended periods out of water. The bearings are lubricated by the water and vibration and noise will be greater when dry.

Clicking Noise

If you hear a clicking noise during operation, especially when operating in air, do not be alarmed. It's normal.

The thruster uses solid plastic bushings and due to the tolerances of the bushings and motors shafts, the shaft can move slightly in the bearing. The noise is drastically reduced or eliminated when operated in water. The water acts as a lubricant for the bearings and smooths operation.

Care and Maintenance

The T200 Thruster does not require much maintenance.

Normal Care

During normal use:

- Rinse with fresh water after use in saltwater to minimize the accumulation of salt deposits.
- Rinse after operating in sandy environments to remove sand particles.

If operated for extended periods in the water:

- Occasionally clean biological fouling and mineral deposits from the thruster or performance may be impacted.

Troubleshooting

The motor does not start

This is usually an issue with the proper commands being sent to the ESC.

The motor does not start but the propeller tries to move.

This can be caused by a disconnected motor wire or a short between motor wires. Check that all three motor wires are connected and not shorting.

The motor is jammed when turned by hand.

This can be caused by something jamming the propeller or by major internal damaged caused by overheating, short circuits, or heavily worn bearings. Please disassemble the thruster and inspect for damage or blockage.

Details

For all the engineers out there, here's some more info.

Comparison to T100

Test Results

- Endurance Testing. We have tested the T200 Thruster for up to 300 hours continuous operation at full throttle power.
- Sand and Particulate Testing. The thrusters handle small particulate matter very well. See [this video](#) of testing the thrusters in heavy sand.
- Depth Testing. As of writing, the thrusters have been tested to a maximum depth of 3000m (4500 psi) in static conditions. This testing was performed by Woods Holes Oceanographic Institution.

Quality Control

We perform the following tests on every thruster before they are shipped.

- Insulation Test, also know as a hipot test. We submerge the thruster in water and measure current leakage at high voltage (250V) to ensure that the insulation is sufficient.
- Spin Test. The thruster is operated in air across the entire speed range to ensure that it operates correctly.
- Visual Inspection. Each thruster is inspected for visual issues or damage.

Painting the Thruster

If you want the thruster to match the color scheme of your vehicle, you can paint the propeller and other components. We have tested Tamiya Spray Paint for Polycarbonate which comes in many colors and works well on the plastic.