

## GS2 DATA SHEET



# CONTENTS

<b>1</b>	<b>PRODUCT OVERVIEW</b> .....	<b>1</b>
1.1	Product Features .....	1
1.2	Applications .....	1
1.3	Installation and Dimensions.....	1
<b>2</b>	<b>SPECIFICATIONS</b> .....	<b>4</b>
2.1	Performance Parameter .....	4
2.2	Electrical Parameter.....	4
2.3	Interface Definition.....	5
2.4	Data Communication .....	6
2.5	Optical Characteristic.....	6
2.6	Others .....	7
<b>3</b>	<b>REVISE</b> .....	<b>8</b>

# 1 PRODUCT OVERVIEW

YDLIDAR GS2 is a Linear array solid LiDAR (hereinafter referred to as GS2) developed by EAI team. Based on the principle of Triangulation, it is equipped with related optics, electricity, and algorithm design, to achieve 100 degrees high-precision laser distance measurement, and output point cloud data of the scanning environment. It can be used for robot obstacle avoidance, path planning, etc.

## 1.1 Product Features

- High accuracy, stable performance
- High resolution of ranging angle, up to 0.6 degrees
- Good obstacle avoidance effect, the smallest object with a diameter of 3mm can be detected
- Wide detection range, no blind zone in combination, FOV up to 100 degrees
- Small detection range blind area, detectable distance is 25mm~300mm
- Class I eye safety
- 10000h Service life

## 1.2 Applications

- Robot obstacle avoidance
- Obstacle avoidance of smart equipment
- Navigation and obstacle avoidance of home service robots/vacuum clean robots

## 1.3 Installation and Dimensions

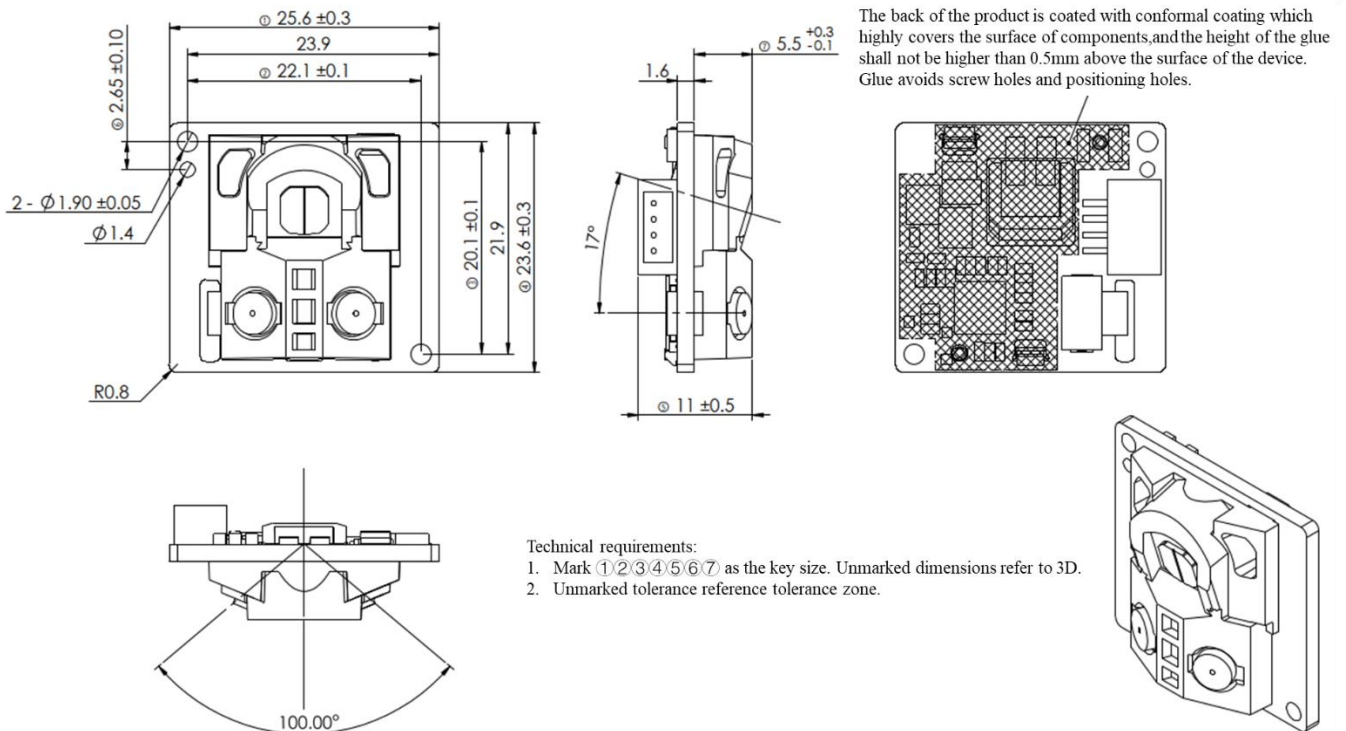
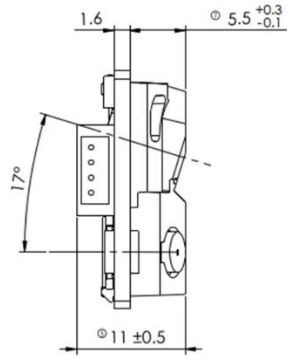
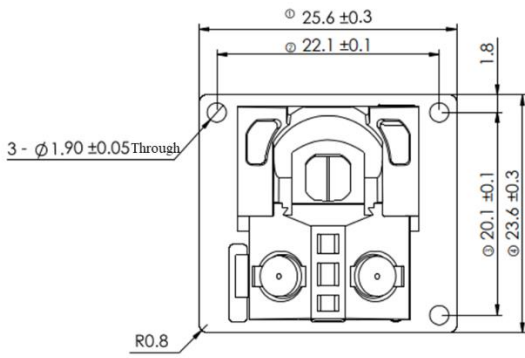
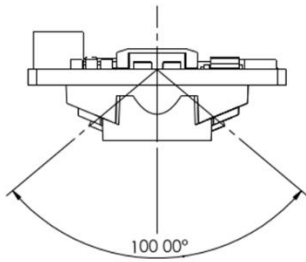
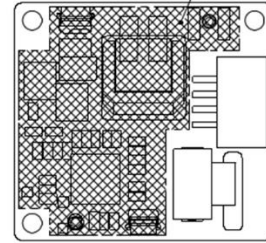

FIG 1A YDLIDAR GS2-S808G01 INSTALLATION&MECHANICAL SIZE (SCREW SPECIFICATIONS: PB1.7MM)



The back of the product is coated with conformal coating which highly covers the surface of components, and the height of the glue shall not be higher than 0.5mm above the surface of the device. Glue avoids screw holes and positioning holes.



Technical requirements:

1. Mark ①②③④⑤⑥ as the key size. Unmarked dimensions refer to 3D.
2. Unmarked tolerance reference tolerance zone.

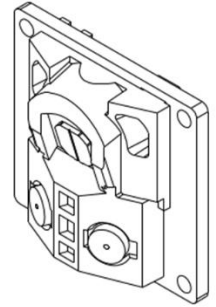
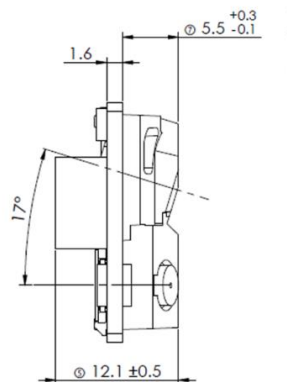
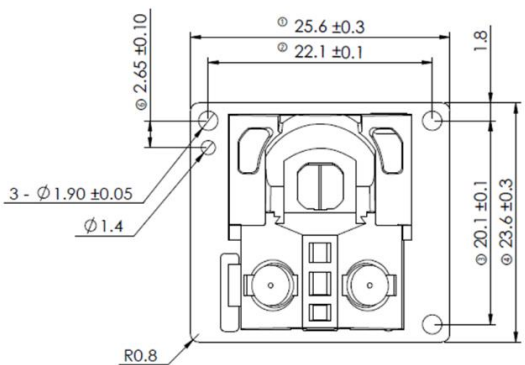
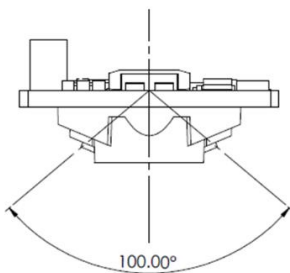
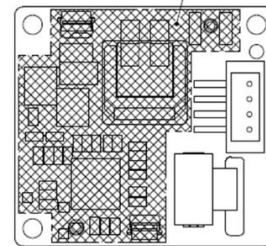

FIG 1B YDLIDAR GS2-S850G01 INSTALLATION&MECHANICAL SIZE (SCREW SPECIFICATIONS: PB1.7MM)



The back of the product is coated with conformal coating which highly covers the surface of components, and the height of the glue shall not be higher than 0.5mm above the surface of the device. Glue avoids screw holes and positioning holes.



Technical requirements:

1. Mark ①②③④⑤⑥⑦ as the key size. Unmarked dimensions refer to 3D.
2. Unmarked tolerance reference tolerance zone.

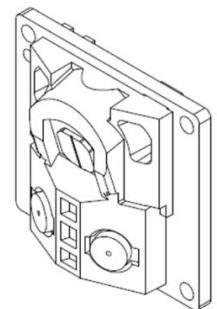

FIG 1C YDLIDAR GS2-TxxxG01 INSTALLATION&MECHANICAL SIZE (SCREW SPECIFICATIONS: PB1.7MM)

Note: GS2 has two forms of use, GS2-T stands for top entry type, GS2-S stands for side entry type, and the default factory is side entry type.

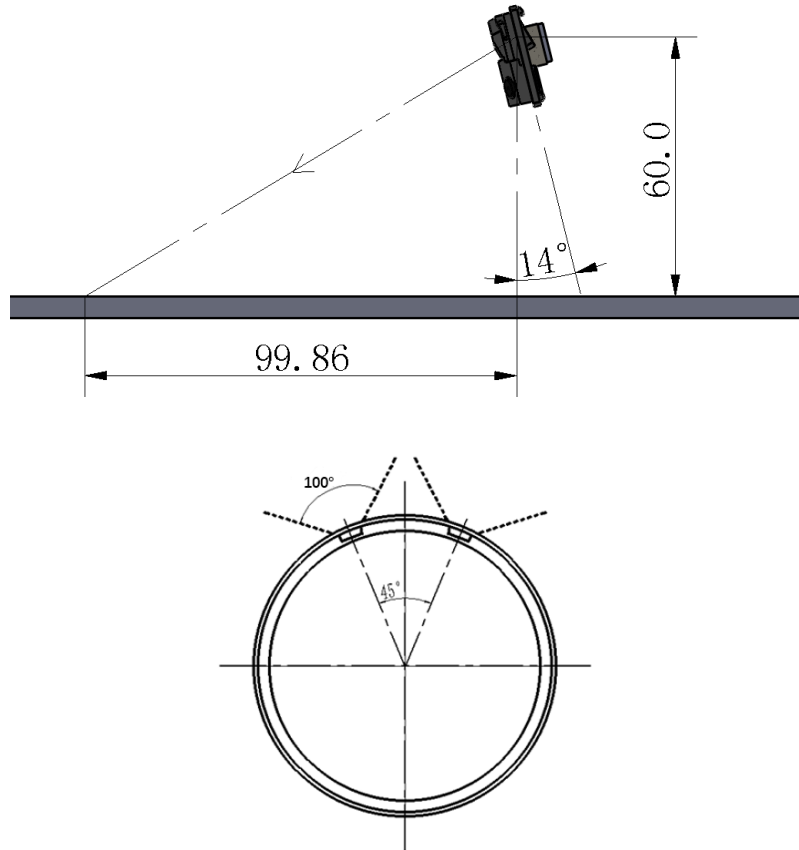

FIG 2A YDLIDAR GS2 OBSTACLE AVOIDANCE REFERENCE INSTALLATION DRAWING (UNIT MM)

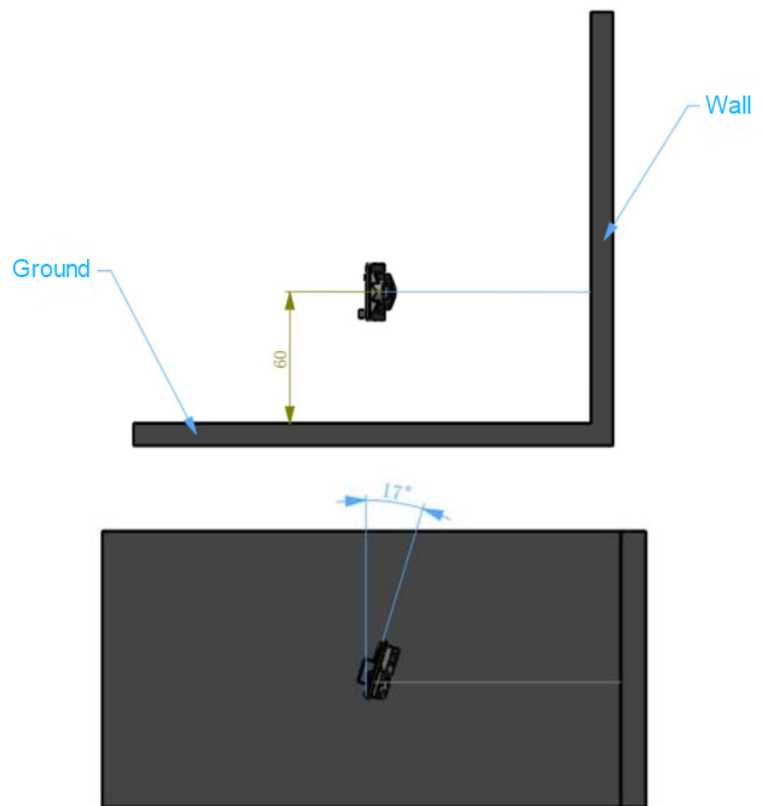

FIG 2B YDLIDAR GS2 EDGE REFERENCE INSTALLATION DRAWING (UNIT MM)

## 2 SPECIFICATIONS

### 2.1 Performance Parameter

**CHART 1 YDLIDAR GS2 PERFORMANCE PARAMETER**

Item	Min	Typical	Max	Unit	Remarks
Ranging frequency	7.5	/	28	Hz	Indicates the ranging times per second, and the frequency changes in real time according to the scene
Ranging distance	25	/	300	mm	80% reflectivity
Field of view	100	/	108	Deg	/
Angle resolution	/	0.6	/	Deg	/
Relative error	/	≤3	/	mm	Distance ≤ 100mm
	/	≤3%	/	/	100 < Distance < 200mm
	/	≤8%	/	/	200 ≤ Distance < 300mm
Angle error	/	±3	/	Deg	/
Sunlight resistant	/	/	25k	Lux	/
Life-time	10000	/	/	h	/

Note 1: It is factory FQC standard value, 80% reflectivity material object.

Note 2: The relative error value indicates the accuracy of the Lidar measurement. Relative error (mean value) = (average measured distance - actual distance) / actual distance \* 100%, sample size: 100pcs.

Note 3: Lidar is a precision device, please avoid using Lidar under high or low temperature or strong vibration situation, the relative error parameter index will be relatively larger, and it may exceed the typical value.

### 2.2 Electrical Parameter

**CHART 2 YDLIDAR GS2 ELECTRICAL PARAMETER**

Item	Min	Typical	Max	Unit	Remarks
Supply voltage	3.2	3.3	3.4	V	Excessive voltage might damage the Lidar while low affect normal performance
Voltage ripple	0	78	90	mV	High ripple effects performance or even distance measurement
Start-up current	/	240	/	mA	/
Working current	/	100	/	mA	/

## 2.3 Interface Definition

GS2 provides ZH1.5-4P receptacle, which has system power supply and data communication interface (functional interface can be customized), and has two specifications of side entry type(3A) and top entry type(3B).

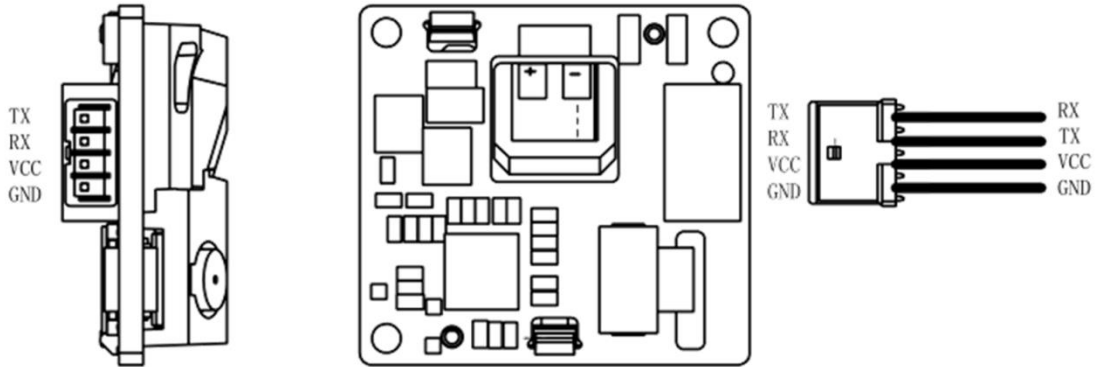

FIG 3A YDLIDAR GS2-SxxxG01 INTERFACE

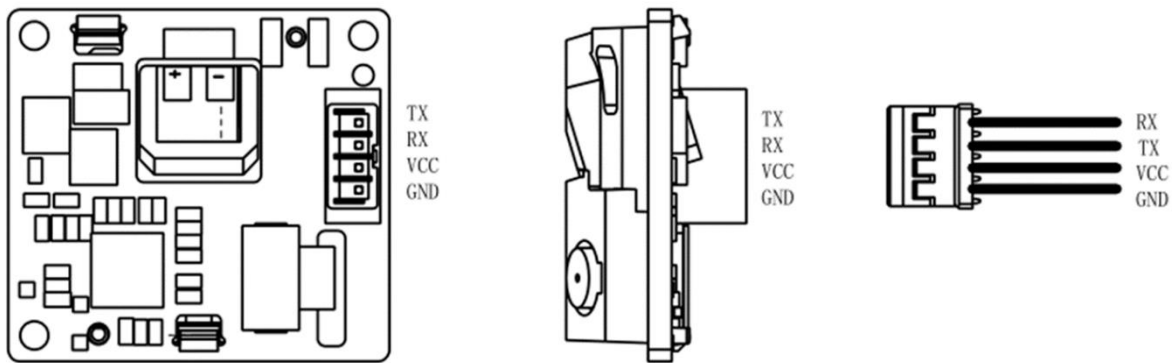

FIG 3B YDLIDAR GS2-TxxxG01 INTERFACE

Note: The plug insertion method of the top entry type and side entry type is mirrored, please refer to the schematic diagram for details, and pay attention to the line sequence.

### CHART 3 YDLIDAR GS2 INTERFACE DEFINITION

Pin	Type	Description	Defaults	Range	Remarks
VCC	Power supply	Positive	3.3V	/	/
Tx	Output	System serial port output	/	/	Data stream: LiDAR→Peripherals
Rx	Input	System serial port Input	/	/	Data stream: Peripherals→LiDAR
GND	Power supply	Negative	0V	0V	/

## 2.4 Data Communication

With a 3.3V level serial port (UART), users can connect the external system and the product through the physical interface. After that, it can obtain the real-time scanned point cloud data, device information as well as device status, and can set the working mode of the equipment, etc. The communication protocol of parameters are as follows:

**CHART 4 YDLIDAR GS2 SERIAL SPECIFICATION**

Item	Min	Typical	Max	Unit	Remarks
Baud rate	/	921600	1500000	bps	8-bit data bit,1 stop bit, no parity
High signal level	2.4	3.3	3.4	V	Signal voltage>2.4V is high signal
Low signal level	0	0	0.5	V	Signal voltage<0.5V is low signal

## 2.5 Optical Characteristic

The infrared point pulse laser used in GS2 can ensure the safety of human and pet. The lidar has passed testing and conformed to Class I, 21 CFR 1040.10 and 1040. 11 safety level, except for IEC 60825-1 Ed. 3., as described in Laser Notice No. 56, dated May 8, 2019.

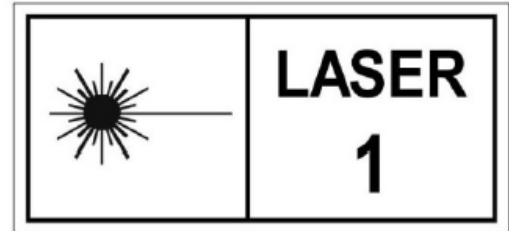

The laser and optical lens finish the transmission and reception of the laser signal to achieve high-frequency ranging while working. To ensure system ranging performance, please keep the laser and optical lens clean. The detailed optical parameters are as follows:

**CHART 5 YDLIDAR GS2 LASER OPTICAL PARAMETERS**

Item	Min	Typical	Max	Unit	Remarks
Laser wavelength	798	808	818	nm	GS2-x808x01 Infrared band
	840	850	860	nm	GS2-x850x01 Infrared band
Laser power	/	25	/	mW	/
FDA	 Class I IEC60825-1				
FPC description	Yellow FPC/ Screen printing 808 Black FPC/ Screen printing 850				

Note: The personal adjustment or reassembly of the Lidar may result in hazardous radiation exposure.



## 2.6 Others

### CHART 6 YDLIDAR GS2 OTHERS

Item	Min	Typical	Max	Unit	Remarks
Operating temperature	-10	25	40	°C	Long-term working in a high temperature environment will reduce the life span
Storage temperature	-30	25	70	°C	/
weight	/	4.2	/	g	N.W. (Without cable)

### 3 REVISE

Date	Version	Content
2021-06-24	1.0	Compose a first draft
2021-11-03	1.1	Update related structure diagram
2021-11-08	1.2	Added support for 1.5Mbps serial port baud rate
2022-01-07	1.3	Increase the appearance tolerance and apply the installation drawing along the edge, revise Band and current
2022-03-28	1.4	1) Update fig 1: installation & mechanical size 2) Update fig 3: GS2 interface
2022-05-09	1.5	1) Chart 1: add angle error 2) Chart 2: update start-up current and working current 3) Update installation&mechanical size (FIG 1A to 1C)
2022-06-20	1.6	1) Update Fig 2A YDLIDAR GS2 obstacle avoidance reference installation drawing 2) Update fig 3: GS2 interface in section 2.3 3) Update chart 1 minimum ranging frequency as 7.5Hz
2022-07-28	1.7	Chart 5: update maximum and minimum value of GS2-x808x01 laser wavelength
2022-10-21	1.8	1) Update fig 1A&1B 2) Update Chart 2 start-up current and working current