

FULL ONE YEAR WARRANTY on Sherline's 3.5" Metal Lathe, Vertical Milling Machine and Accessories

If within one year from the date of purchase a new* Sherline power tool or accessory fails due to a defect in material or workmanship, Sherline will repair it free of charge. In addition, it has always been our policy to replace at no cost all parts, regardless of age, which are determined to have been incorrectly manufactured or assembled and have failed due to this cause rather than because of improper use or excessive wear caused by continuous use in a production environment. In cases such as this, Sherline will inspect the machine or part and will be the sole judge of the merit of the claim. Freight charges for returning a machine are not covered. Merchandise which has been abused or misused is not subject to warranty protection.

Warranty service is available by simply returning the machine, defective assembly or part to:

Sherline Products, Inc., 3235 Executive Ridge, Vista, CA 92083-8527

Please write, fax, call or e-mail to let us know that you are returning a part and to receive a return authorization number. This will speed up the warranty process. (E-mail is sherline@sherline.com)

This warranty gives you specific legal rights, and you may also have other rights which vary from state to state.

*NOTE: Only new machines purchased directly from Sherline or from an Authorized Sherline dealer are covered under this warranty. Machines purchased from a non-authorized source are considered "used" and are not subject to warranty even if they appear to be new. If you are in doubt about the status of a dealer or are suspicious about an offer, you should confirm the dealer's status by checking our dealer listing at www.sherline.com/dealers.htm or by calling (800) 541-0735 for confirmation. Proof of date of purchase and dealer name may be required for service under this warranty.

SHERLINE SERVICE POLICY

Sherline's policy regarding customer service is simple: **CUSTOMER SATISFACTION!**

Because products manufactured by Sherline are completely produced in our Vista, California plant, we offer fast and reasonably priced service. All we ask when you pack the items for shipping is to use common sense, individually protecting items from one another during shipping. Ship by UPS whenever possible. If you have attempted a repair and then decide to return the item it is not necessary to reassemble the machine. If you have lost a part, don't worry, we'll still get it looking great for you and return it via UPS*. Equipment will be returned C.O.D. if it is not warranty work.

Cleaning the returned items thoroughly before you ship them will save time and money.

*If merchandise is received damaged by UPS, keep the original shipping carton and contact your local UPS office.

HOW TO ORDER REPLACEMENT PARTS

The model number of your machine will be found on the nameplate attached to the top or side of the headstock. The serial number is located on the back of the headstock. Always mention the model number when requesting service or repair parts for your machine or accessories.

Replacement parts may be ordered from the factory or from any Sherline dealer. The most expeditious way to order parts is directly from the factory by phone. Sherline's office hours are 8 A.M. to 4 P.M. (PST or PDT) Monday through Friday. Orders received before 12 noon (Pacific Standard or Daylight Time) will be shipped the same day. We accept payment by Visa, MasterCard, Discover or American Express.

Parts orders:

Toll free order line: (USA)1-800-541-0735

International or Technical Assistance: 1-760-727-5857 • Fax: 760-727-7857

SHERLINE IS ON THE INTERNET

To take a look at the newest offerings from Sherline Products, look in on our Internet site. You will find a complete list of all our accessories as well as the fully illustrated instructions for each one. Learn how a part is used before deciding to buy, or print out the directions for your later use. There is also a U.S. and worldwide dealer listing, replacement parts listing, current price

list as well as a "Resources" page with hot links to many other items of interest to miniature machinists. There is even a "factory tour" in photos. You have a wealth of free information at your fingertips. Our address is: www.sherline.com. You may now place your order by e-mail at sherline@sherline.com or order on-line 24 hours a day at www.sherlinedirect.com.

TABLE OF CONTENTS

Sherline warranty and service policy	1	Inserted tip carbide tools	24
Ordering replacement parts	1	Turning speeds and feed rates, general rules	24
Safety rules for power tools	3	Accessories for the lathe	
An introduction to the world of miniature machining	4	3-Jaw, 4-jaw and drill chucks	25
General precautions	4	Thread-cutting attachment	25
Customer's responsibilities	5	Steady rest	26
Learning more about machining	5	Additional lathe accessories	26
Lubrication	5	3-JAW CHUCK OPERATION	28
Initial assembly of a new machine	5	VERTICAL MILLING MACHINE OPERATION	
Mounting the lathe crossslide	6	General description	29
Installing the mill X-axis handwheel	6	Helpful tips for machining	29
Installing the mill X-axis digital readout handwheel	6	Mill terminology	30
5000/5400-series mills, installing the column	7	Securing the workpiece	30
2000-series mills, installing the multi-direction column	7	Before you cut	31
Mounting the motor and speed control assembly	7	Purchasing raw materials	31
What to do if the motor shuts down	8	Types of work	32
Operation of the motor and speed control	9	Types of milling cutters	32
Industrial applications for Sherline components	9	Standard milling vs. "climb" milling	32
Mounting the headstock to the lathe or mill	9	Working to a scribed layout line	33
Mounting lathe and mill to a base board	10	Use of a dial indicator	33
Converting machines from inch to metric	10	Accurately locating the edge of a part	34
ADJUSTMENTS		Determining the depth of cut	35
2-speed pulley	10	Suggested cutting speeds, end mills and drills	35
Preload	11	End mills	35
Gibs	11	Locking the column saddle	36
Leadscrew backlash	11	Accessories for the milling machine	
Handwheels	11	Sensitive drilling attachment	36
Saddle nut	12	3/8" end mill holder	36
Tailstock gib adjustment	12	Mill collet set	36
Aligning the lathe headstock and tailstock	12	Boring head	37
Aligning your mill	13	Fly cutter	37
Use of cutting oils	17	Drills and drill chuck, center drills	37
General machining terms	17	Milling vise	38
Rules for feed rates and cutting speeds	17	Step block hold-down set	38
LATHE OPERATION		Tilting angle table	38
Leveling the tool	18	4" rotary table	38
Initial test cutting	18	CNC rotary indexer	39
Lathe terminology	19	Horizontal milling conversion	39
Controlling "chatter"	19	Multi-direction column upgrade	39
Holding the workpiece	19	Additional mill accessories	40
Turning between centers	19	Books and videos for machinists	41
Removing tools from Morse tapers	20	Speed control electrical wiring layout and color codes	41
Center drilling	20	Exploded view, typical CNC stepper motor mount	41
Tailstock drilling	20	Exploded view, 4000/4400-series lathes	42
Headstock drilling	21	Exploded view, 5000/5400-series mills	43
Reaming	21	Exploded view, 2000 series 8-direction mill	44
Faceplate turning	21	Part numbers and descriptions	45
Taper turning	21	Tips on using the handwheels	46
Tool shapes and cutting angles, use of tools	21	Technical specifications, lathes and mills	46

"A man who works with his hands is a laborer.

A man who works with his hands and his brain is a craftsman.

A man who works with his hands, his brain and his heart is an artist."

—Louis Nizer

SAFETY RULES FOR POWER TOOLS

- 1. KNOW YOUR POWER TOOL**—Read the owner's manual carefully. Learn its application and limitations as well as the specific potential hazards peculiar to this tool.
- 2. GROUND ALL TOOLS**—If a tool is equipped with a three-prong plug, it should be plugged into a three-hole receptacle. If an adapter is used to accommodate a two-prong receptacle, the adapter wire must be attached to a **KNOWN GROUND**. Never remove the third prong. (See Figure 1 in right-hand column.)
- 3. KEEP GUARDS IN PLACE**—and in working order.
- 4. REMOVE ADJUSTING KEYS AND WRENCHES**—Form a habit of checking to see that keys and adjusting wrenches are removed from the tool before turning on any machine.
- 5. KEEP WORK AREA CLEAN**—Cluttered areas and benches invite accidents.
- 6. AVOID A DANGEROUS WORK ENVIRONMENT**—Do not use power tools in damp or wet locations. Keep your work area well illuminated.
- 7. KEEP CHILDREN AWAY**—All visitors should be kept a safe distance from the work area.
- 8. MAKE YOUR WORKSHOP KID-PROOF**—with padlocks, master switches or by removing starter keys.
- 9. DO NOT FORCE A TOOL**—Do not force a tool or attachment to do a job for which it was not designed. Use the proper tool for the job.
- 10. WEAR PROPER APPAREL**—Avoid loose clothing, neckties, gloves or jewelry that could become caught in moving parts. Wear protective headgear to keep long hair styles away from moving parts.
- 11. USE SAFETY GLASSES**—Also use a face or dust mask if a cutting operation is dusty.
- 12. SECURE YOUR WORK**—Use clamps or a vise to hold work when practicable. It is safer than using your hand and frees both hands to operate the tool.
- 13. DO NOT OVERREACH**—Keep your proper footing and balance at all times.
- 14. MAINTAIN TOOLS IN TOP CONDITION**—Keep tools sharp and clean for best and safest performance. Follow instructions for lubrication and changing accessories.
- 15. DISCONNECT TOOLS**—Unplug tools before servicing and when changing accessories such as blades, bits or cutters.
- 16. AVOID ACCIDENTAL STARTING**—Make sure the switch is "OFF" before plugging in a power cord.
- 17. USE RECOMMENDED ACCESSORIES**—Consult the owner's manual. Use of improper accessories may be hazardous.
- 18. TURN THE SPINDLE BY HAND BEFORE SWITCHING ON THE MOTOR**—This ensures that the workpiece or chuck jaws will not hit the lathe bed, saddle or crossslide, and also ensures that they clear the cutting tool.
- 19. CHECK THAT ALL HOLDING, LOCKING AND DRIVING DEVICES ARE TIGHTENED**—At the same time, be careful not to overtighten these adjustments. They should be just tight enough to do the job. Overtightening may damage threads or warp parts, thereby reducing accuracy and effectiveness.
- 20. DON'T USE YOUR LATHE FOR GRINDING**—The fine dust that results from the grinding operation is extremely hard on bearings and other moving parts of your tool. For the

same reason, if the lathe or any other precision tool is kept near an operating grinder, it should be kept covered when not in use.

21. DON'T LET LONG, THIN STOCK PROTRUDE FROM THE BACK OF THE SPINDLE—Long, thin stock that is unsupported and turned at high RPM can suddenly bend and whip around.

22. WEAR YOUR SAFETY GLASSES—Foresight is better than **NO SIGHT!** The operation of any power tool can result in foreign objects being thrown into the eyes, which can result in severe eye damage. Always wear safety glasses or eye shields before commencing power tool operation. We recommend a Wide Vision Safety Mask for use over spectacles or standard safety glasses.

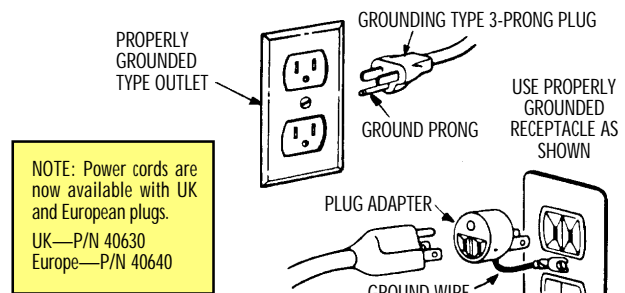

FIGURE 1—Proper grounding for electrical connections.

ELECTRICAL CONNECTIONS

The power cord supplied is equipped with a 3-prong grounding plug that should be connected only to a properly grounded receptacle for your safety. Should an electrical failure occur in the motor, the grounded plug and receptacle will protect the user from electrical shock. If a properly grounded receptacle is not available, use a grounding adapter to adapt the 3-prong plug to a properly grounded receptacle by attaching the grounding lead from the adapter to the receptacle cover screw.

NOTE: The electrical circuit designed into the speed control of your lathe or mill reads incoming current from 100 to 240 volts AC and 50 or 60 Hz and automatically adapts to supply the correct 90 volts DC to the motor. As long as you have a properly wired, grounded connector cord for your source, the machine will operate anywhere in the world without a transformer. This has been true for all Sherline machines built since 1994. Prior to that, we used an AC/DC motor. Use that motor **ONLY** with the power source for which it was intended. It will not automatically adapt to any other current and using it with an improper power source will burn out the motor or speed control. Also, the first few DC units built did not include the circuits to adapt to other currents. If you think you may have an early DC model, remove the plastic speed control housing and look for a label on the aluminum speed control frame. If it has a small metallic label on top of the frame that lists input voltage as 120VAC, **DO NOT ATTEMPT TO CONVERT TO OTHER CURRENTS**. Models that can be used with any current have a paper label on the end of the speed control frame which lists the model number as KBLC-240DS.

AN INTRODUCTION TO THE WORLD OF MINIATURE MACHINING

Getting answers to your questions about machining

Over the years we have found that the majority of our customers are both highly intelligent and skilled craftsmen. Often they are also new to machining. The instructions we have included in this book, while far more extensive than anything included with other machine tools, even ones costing thousands of dollars, still only scratch the surface when it comes to machining. We have tried to anticipate the most common problems and questions asked by a new machinist. What we have provided in this book and with each accessory, when combined with a liberal amount of common sense, is more than enough to get you started. If you apply what you learn here, you will be well on your way to making good parts. No doubt you will also have many questions specific to your project that simply can't be addressed in a booklet of this type.

Answers to questions beyond the scope of this booklet will have to come from your own research. Bookstores and libraries are full of excellent books on machining, and the Internet is forming some great user groups that can put you in direct contact with others who share your specific interests. Our own Worldwide Web site is a great source of information as well. We have published there all the instructions for all our tools and accessories for you to read and print out for free. There are also links to many other fascinating sites. For the past thirty-five years I have found *Machinery's Handbook* to be the source I turn to for answers to my own questions.

I recently wrote a book called *Tabletop Machining* that is specifically directed to the owners of Sherline tools and to anyone who wants to learn to make small, metal parts. The instructions you are reading that come with your machine are quite complete; however, if you want to get into more detail or want to see color photos of setups and projects made by some of the best craftsmen around, I am sure you will find more than your money's worth in *Tabletop Machining*. May your journey toward becoming a skilled machinist be an enjoyable one.

What new machinists like most and least

If you are new to machining, you may find it to be either one of the most rewarding skills one can learn or the most frustrating thing you have ever attempted. What makes machining fun for some is the complexity and challenge. The same thing will drive others up the wall. One customer may be overjoyed because he can now make parts that were not available for purchase. Another may wonder why

he just spent all day making a part that is similar to one he could have purchased for two dollars. The difference is that it is not the same as the two-dollar part—it is *exactly* the part needed.

There are no shortcuts

Machining is a slow process because parts are made one at a time. The interesting thing is, a skilled machinist may take almost as long to make the same part as a novice. Shortcuts usually end in failure. Unlike some other trades, mistakes cannot be covered up. There are no erasers, white-out or “putting-on tools” for machinists; you simply start over. To expand a little on an old rule: “*Think three times, measure twice and cut once!*”

The craftsman's strength—anticipating a tool's limitations

The skill in machining isn't just “moving the dials.” It is a combination of engineering and craftsmanship. A file is just as useful a tool to a good machinist as a multi-thousand-dollar machine tool. Tools “deflect” or bend under load, and anticipating this bend is what it is all about. Sharp tools deflect less than dull tools, but with each pass the tool gets a little duller and the deflection becomes greater. If you try to machine a long shaft with a small diameter, the center will always have a larger diameter than the ends, because the part deflects away from the tool where it has less support. You can go crazy trying to machine it straight, or you can simply pick up a good, flat mill file and file it straight in a few moments. Machine tools will never replace the “craftsman's touch,” and machining is a combination of both good tools and good technique.

You don't become a machinist by buying a machine

You should strive from the beginning to make better and more accurate parts than you think you need. Work to closer tolerances than the job demands. Be on the lookout for ways to make a job easier or better. Having a selection of appropriate materials on hand and a good cutoff saw to get them to rough size is a good start. Take some time and read through this instruction book before you try machining anything. We want you to enjoy the process of creating accurate parts from raw metal. Buying a machine didn't make you a machinist, but using it along with the skill and knowledge you acquire along the way eventually will. With the purchase of Sherline equipment, you have taken your first step toward many years of machining satisfaction. We thank you for letting us be a part of that.

—Joe Martin, President and owner
Sherline Products Inc.

GENERAL PRECAUTIONS

- **DO NOT** attempt to operate the lathe or mill without first mounting them to a secure base. (See page 10.)
- **DO NOT** turn on the motor with a 3-jaw chuck mounted if the jaws are not tightened on themselves or on a part. The acceleration of the spindle can cause the scroll to open the chuck jaws if not tightened.

- **DO NOT** lift or carry the machine by the motor. The motor mount was not designed to support the entire weight of the machine. Carry the machine by lifting under the base or by the mounting board. It is also advisable to remove the headstock/motor/speed control unit when transporting the machine. The inertia of a sudden shock can also overstress the motor mount.

- A chip guard (P/N 4360) is now available that offers additional protection from flying chips when working near the spindle. It is not a substitute for wearing proper eye protection, but it does offer additional protection. It will also contain cutting oil to help keep your work area cleaner.

————— **AVOID OVERTIGHTNING!** —————

One of the problems with designing and manufacturing metal cutting equipment of this size is that the operator can physically be stronger than the machine, which is not normally the case with larger tools. For example, a 10-pound force applied a couple of inches out on a hex key becomes a 650-pound force at the tip of the screw. If you tighten both screws on the tool post this tight, it becomes approximately 1300 pounds of force on relatively small parts! Tools and/or parts can become distorted and accuracy will be lost. **Overtightening hold-down screws and T-nuts in their slots can distort the crossslide or mill table.** It is not necessary to overtighten parts and tools, because loads are smaller on equipment of this size. Save your equipment and increase accuracy by not overtightening and by taking light cuts.

————— **DON'T OVERSTRESS THE MOTOR!** —————

It is also important to realize that you can overload the motor supplied with this lathe or mill.* The many variables involved in machining, such as materials being machined, size of cutter, shape of cutter, diameter of stock, etc., can leave but one rule to follow...**COMMON SENSE!**

*The motor is thermally protected, so if it is overloaded, it will simply shut down until it cools. See note on thermal protection in the *motor/speed control* section on page 8.

————— **CAUTION!** —————

Read all operating instructions and safety rules carefully before attempting any machining operations.

LUBRICATION

MACHINE SLIDES—Use a light oil such as sewing machine oil or grease on all points where there is sliding contact. This should be done immediately after each cleanup. (We grease the slides at the factory to ensure the lubrication stays in place during shipping, but light oil will work fine once you begin using the machine.)

LEADSCREW, TAILSTOCK SCREW, CROSSLIDE SCREW—Sewing machine oil should be placed along all threads regularly. At the same time, check that the threads are free from any metal chips. Use an air hose or inexpensive paint brush to keep them clean.

TAILSTOCK SPINDLE—Wind out the spindle as far as it will go and lightly oil it with sewing machine oil.

HANDWHEELS—A few drops of light oil or a little grease behind the handwheel will reduce friction between the surfaces and make operation easier and smoother.

HEADSTOCK BEARINGS—These bearings are lubricated at the factory for the lifetime of the machine and should not need further lubrication. DO NOT break the seals.

THE CUSTOMER'S RESPONSIBILITIES

Always use care when operating the lathe and mill. Follow the safety rules for power tools on page 3. Turn off the motor before attempting adjustments or maintenance. (Do not simply turn the speed control down to zero RPM but leave the motor switch on.) Be sure the work piece is firmly supported on the lathe or mill. Accessories should be mounted and operated following instructions carefully. Keep your machine clean, lubricated and adjusted as instructed. Do not leave cleaning rags, tools or other materials on the lathe bed or around moving parts of the machine.

LEARNING MORE ABOUT MACHINING

Many fine books have been written on machining techniques and are available at your local library or bookstore. Although these books often refer to machines many times larger than Sherline's tools, the principle remains the same. Sherline offers several good books related specifically to miniature machining. See page 41 and the back cover for more.

Visit the Sherline Web Site for the Latest Updates
A world of up-to-date information on Sherline tools and accessories and their use is available at:

www.sherline.com

Here are a few key addresses (www.sherline.com/...):

Accessory instruction links: [accessor.htm](#)

Links to interesting and informative sites: [resource.htm](#)

Projects by Sherline machinists: [workshop.htm](#)

Replacement parts price list: [prices3.htm](#)

Reference dimensions of Sherline tools: [dimen.htm](#)

Sources for raw materials: [online.htm](#)

Tips from Sherline machinists: [tips.htm](#)

Sherline photo factory tour: [factour.htm](#)

Special instructions and help sheets: [hlp-sheet.htm](#)

MOTOR—Sealed ball bearings require no maintenance.

When NOT to lubricate certain surfaces

The mating surfaces of the arm, the column and the column cap on the Model 2000 mill are to be kept free from lubrication. Tightening the column bolt causes friction between these surfaces to resist movement of the arm during the forces and vibration of machining. If these smooth surfaces are lubricated, the arm or the column could move during machining even if the bolt is securely tightened. Clean these surfaces periodically with mild detergent or bathroom spray cleaner to keep a good "bite" between surfaces. The same goes for the surfaces between the "knuckle" and the ends of the swing arm. These surfaces are smooth enough that adjustment is easily accomplished with the nut loosened even without lubrication. They should be free of dirt and chips, but please resist your natural inclination to lubricate them, as they do their intended job better when dry.

A Note on Synthetic Greases

We have recently begun using a Teflon-based synthetic grease to lubricate not only the Sherline tools we sell, but

also the factory machines that we use to produce them. Several manufacturers now offer it in small grease gun canisters that are available at hardware and auto part stores. It offers smoother action than conventional grease when used on sliding parts, and we highly recommend it.

INITIAL ASSEMBLY OF A NEW MACHINE

Your new lathe or mill will come packed in a box with some items disassembled for shipping purposes. This has been done to minimize the chance of damage during shipping. On the lathe, you will install the crossslide table onto the saddle. On the mill you will install the Z-axis column onto the base. On some mills you will reinstall the X-axis handwheel. On both machines you will need to install the motor and speed control. The machines are completely assembled and tested for fit at the factory prior to shipping. They are then disassembled and packaged, so everything should go together easily when you reassemble it. The motors are “run in” for approximately one hour to assure proper function and seating of the brushes.

Before you call us and say a part is missing, please look carefully through the packaging. Some parts are in bags taped to the bottom of cardboard flaps or spacers, and you may not notice them when you open the box and remove the major components.

LATHE—MOUNTING THE CROSSLIDE

Installation of the crossslide requires no tools. First, make sure the bottom of the crossslide has a light coat of grease on all the sliding surfaces. This will have been applied at the factory, just make sure it has not been wiped off and that it is evenly distributed.

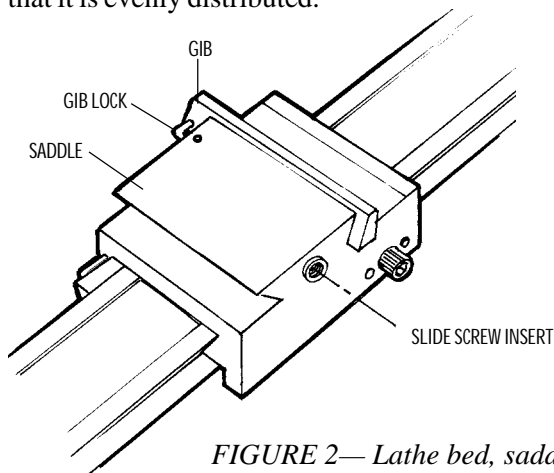

FIGURE 2— Lathe bed, saddle and gib

Next, see that the gib is in the proper position on the saddle. (See Figure 2.) It is taped into position for shipping. Remove the tape holding it in place. If the gib has come off, reposition it on the gib lock as shown.

Set the dovetail of the crossslide over the gib and matching dovetail on the saddle. Slide it onto the saddle about 1/4" (6-7 mm) until it stops. (See Figure 3.)

Look underneath and align the slide screw with the threads on the brass slide screw insert on the side of the saddle. (See Figure 4.) Turn the crossslide handwheel clockwise to

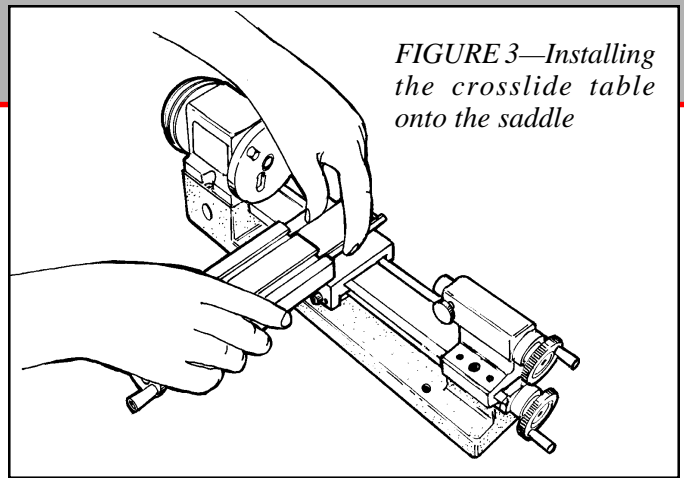

FIGURE 3—Installing the crossslide table onto the saddle

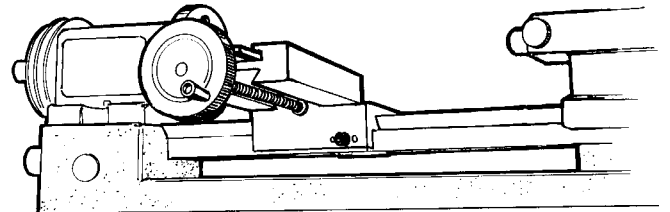

FIGURE 4—Aligning the slide screw with the brass slide screw insert

engage the threads. Continue to crank the handwheel clockwise until the crossslide is in the desired position on the saddle.

MILL—X-AXIS HANDWHEEL INSTALLATION

Mills with adjustable “zero” handwheels come with the X-axis handwheel removed to prevent damage to the leadscrew during shipping. Reinstalling the handwheel is a simple process:

1. Loosen the X-axis table lock (the barrel-shaped lock on the saddle that is tightened against the side of the mill table with a socket head cap screw). From the end of the mill table where the X-axis leadscrew protrudes, push on the end of the mill table to make sure it seats tightly against the leadscrew.
2. Examine the red collar on the handwheel to see that the small hole is aligned with the head of the set screw. If it is not, loosen the black locking nut on the handwheel and rotate the collar until you can see the head of the set screw.
3. The handwheel was installed at the factory and then removed for shipping. You should be able to see a mark on the leadscrew where the set screw was previously tightened. When reinstalling the handwheel, try to have the set screw pick up this same position on the leadscrew.
4. Slide the handwheel onto the end of the leadscrew shaft and push until the handwheel is fully seated and the thrust collar is clamped tightly between the handwheel and the leadscrew collar. A 3/32" hex wrench is included with your machine to tighten the handwheel set screw.

DIGITAL READOUT HANDWHEELS

If you ordered your mill equipped with a digital readout, the X-axis handwheel will again be removed to prevent damage during shipping. The proper thrust collar has been factory installed. If a 1/4" shim washer is required, it will be included in this package. Place it on the leadscrew shaft before installing the handwheel. Follow the installation instructions

CHECK THE TIGHTNESS OF ALL BOLTS

Vibration in shipping can cause some bolts or screws to loosen up. Before using your new machine, check the tightness of all

fasteners. It is also a good idea to check tightness periodically when using the machine, as vibration from operation may cause some fasteners to loosen up.

included with the P/N 8100 digital readout to install the encoder housing and handwheel unit.

5000-SERIES MILLS—MOUNTING THE COLUMN

The mill is shipped attached to a piece of plywood to keep it from moving in the box. Before you begin, remove the screws holding the mill base to the plywood. It was installed strictly for packing purposes and will need to be removed so that the column can be installed.

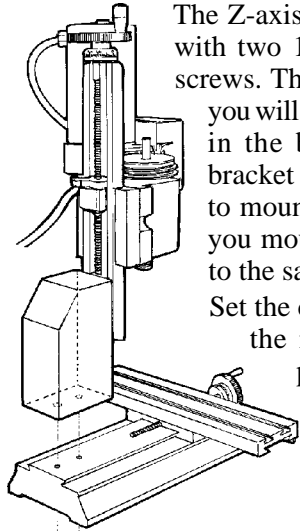

The Z-axis column is mounted to the base with two 1-3/4" long, 1/4-20 socket head screws. These screws and the hex key tool you will need to tighten them are packaged in the bag with the motor mounting bracket and drive belt. It is much easier to mount the column to the base before you mount the motor and speed control to the saddle.

Set the column on the base aligned with the mounting holes and hold it in position while you insert the first screw up from the bottom of the base. Hand-turn the first screw part way in, and then start the second screw. This can be done with the machine upright by letting the base hang over the edge of your table or bench just far enough to expose the first hole. Using the large 3/16" hex key provided, snug up both screws lightly first, and then tighten evenly.

FIGURE 5—Mounting the 5000-series mill Z-axis column

2000-SERIES MILLS—ASSEMBLING AND MOUNTING THE MULTI-DIRECTION COLUMN

To assemble the multi-direction column, make reference to the exploded view on page 44 of these instructions and complete the steps that follow:

1. Attach the round column base (P/N 5666) to the mill base with the two 1/4-20 x 1-1/2" socket head cap screws.
2. Screw the arm hold-down bolt (P/N 5613) into the top of the round column base and tighten with an adjustable wrench using the two flat indentations on the shaft.
3. Slip the round column top (P/N 5655) over the pin and rotate it until the flat sides are parallel to the mill base with the engraved indicator line on the same side as the X-axis handwheel.
4. Using an 11/16" or a 17 mm wrench, loosen the flange nut holding the bed and swing arm together. Rotate the bed away from the swing arm until they are at approximately a 90° angle to each other. Retighten the flange nut firmly to hold the column in this position. Discard the protective spacer that was installed between the bed and arm during shipping.
5. Set the swing arm over the column and align it approximately square with the mill base and in about the center of its travel. Make sure the swing arm registers on the flats of the column top and is properly seated. While still holding the swing arm unit in place, set the hold-down

washer (P/N 5620) over the end of the bolt. Put a flange nut on the end of the bolt and tighten it against the hold-down washer firmly to lock the swing arm in place. NOTE: There should be NO lubrication on the mating surfaces between the arm and the column base. Friction between these surfaces keeps the arm from moving during cuts.

6. Place the column adjustment block (P/N 5635) on top of the swing arm and attach it with two 10-32 x 5/8" socket head cap screws at both ends. Adjust the 1" long center bolt so that it is just touching the flat in the bottom of the relieved section in the top of the pivot knuckle when the column is in the 90° position.

NOTE: If you remove the column adjustment block to accommodate a backward tilt movement of the column, make sure you replace it when returning the column to an upright position. It not only serves as a reference point when returning the column to the 90° position, it also keeps it from accidentally swinging down and damaging the table if the flange nut is loosened.

7. Slip the alignment key into its keyway in the mill saddle. Place the headstock/motor/speed control unit over the pin on the mill saddle and over the alignment key. Tighten the set screw in the side of the headstock to hold the entire unit in place. Recheck to be sure you have tightened the flange nut on the shouldered bolt pivot pin securely so that all the weight of the column is not resting on the column adjustment block bolt.

MOUNTING THE MOTOR AND SPEED CONTROL UNIT TO THE HEADSTOCK

(Refer to Figure 6 and the exploded views and number list on pages 42, 43, 44 and 45 for part number references.)

1. Remove the motor pulley from the motor shaft. Mount the inner belt guard to the motor using the two standoffs (P/N 4310). Next, install the motor pulley (P/N 4336) to the motor shaft and tighten the set screw. The end of the pulley should be just about even with the end of the motor shaft, with the smaller pulley toward the end of the shaft.
2. Place the drive belt over the motor pulley.
3. Place the round post (A) on the speed control hinge plate in the hole on the inner belt guard (B).
4. Set the outer belt guard in place, locating the other post of the hinge plate (C) in its pivot hole (D). The motor standoff ends will register in holes in the outer belt guard. Make sure the drive belt is routed properly, then secure the cover with the two 1-3/8" pan head screws that go into nuts pressed into the back of the inner belt guard.
5. Attach the motor mounting bracket to the rear of the headstock with two 10-32 x 3/8" socket head screws. (These screws are shipped threaded into the headstock rather than in the parts bag.) There is enough "play" in the mounting holes to allow you to ensure the motor is visually mounted parallel with the spindle axis. (Note: If a chip guard is to be mounted, its attachment screw replaces one of these mounting screws. It can be mounted at this time or after the headstock is in place. (See chip guard instructions.)

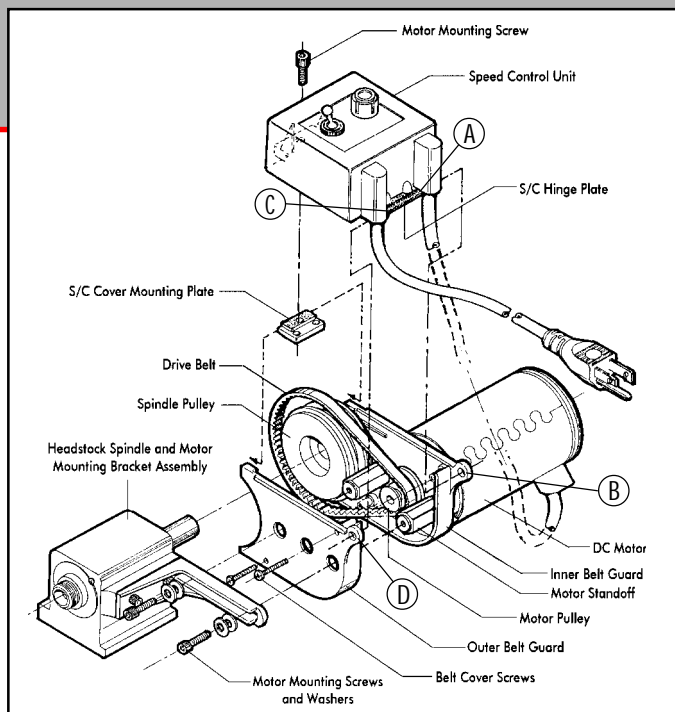

FIGURE 6—DC motor and speed control assembly

6. Place the drive belt over the spindle pulley and insert two 10-32 x 3/4" socket head screws (with 2 washers on each) through the motor mount slot and into holes in the ends of the motor standoffs. (These standoff ends should be exposed through locating holes in the outer belt guard.)

NOTE: The normal operating position for the drive belt is on the large diameter groove on the motor pulley and the small diameter groove on the spindle pulley. Use of the other (low RPM) position is discussed in the instructions on page 10.

7. Tighten the motor mount screws, tilt the speed control unit out of the way and check the alignment of the drive belt. It should be perpendicular to the drive pulleys. If it is not, loosen the set screw on the motor pulley and adjust it in or out on its shaft until the drive belt is square with the motor.

8. Pull the desired tension into the drive belt by sliding the motor unit outward in the bracket slot. Tighten the mounting screws to hold the motor and control unit in place.

NOTE: Do not over-tension the drive belt. Just make sure it has enough tension to drive the spindle pulley without slipping under normal load. By not overtightening the belt you will not only extend its life, but will also provide a margin of safety for belt slippage should a tool jam in a part or an accident occur. The belt must be a little tighter when used in the low speed range because small diameter pulleys are not as efficient.

9. Set the mounting plate into the top of the belt guard housing so it rests on the rails molded onto the inside surfaces of the housing. (The pressed-in nut goes down and to the outside.) Slide the plate toward the outside (toward the spindle pulley) until it stops. NOTE: The mounting plate was designed to be easily removable so it is out of the way when changing the drive belt position.

10. Rotate the speed control unit down into place and insert the single 10-32 x 3/8" socket head screw through the hole

in the speed control housing and into the nut in the mounting plate. Tighten enough to hold it in place. Do not overtighten. NOTE: If you machine a lot of wood or brass, you may want to purchase and install a switch cover (P/N 3015) to keep the fine dust out of the power switch. The wood dust can gum up the switch causing intermittent operation. Brass dust can short out the switch or cause a risk of electric shock to the operator.

THE ADVANTAGES OF SHERLINE'S DC MOTOR AND ELECTRONIC SPEED CONTROL

Sherline's 90-volt DC motor is very smooth and powerful, particularly at low RPM. The specially designed electronics package also provides some unique advantages in addition to smooth speed control with a usable speed range of 70 to 2800 RPM. A special circuit compensates for load, helping to keep RPM constant. The machines can also be used on any current worldwide from 100 VAC to 240 VAC, 50 or 60 Hz without any further adjustment other than seeing that the proper wall plug is used. The control reads the incoming current and automatically adjusts to the proper settings.

CAUTION—MOTOR IS THERMALLY PROTECTED

Thermal protection means there is a built-in circuit breaker that will shut down the motor if it gets too hot. This keeps the motor from burning out. The breaker will automatically reset as soon as the motor cools and you can go back to cutting, but you should be aware of how it works and what to do if the machine suddenly shuts itself down. If your motor is shutting down from overheating on a regular basis, it means you are taking cuts that are too heavy or operating at too high an RPM for long periods. Slow your speed down, reduce your cut or feed rate, and you should have no further problems.

Due to the nature of miniature machining, overloading the machine is a common problem. It is often tempting to try to speed up the process by working faster. Keep in mind this is a small machine, and work with patience and precision—don't be in a hurry. Your parts will come out better, and your machine will last much longer if it is not overstressed.

WHAT TO DO IF THE MOTOR SUDDENLY SHUTS DOWN

If your thermal protection circuit shuts down the motor while work is in progress, immediately shut off the power switch and then back the tool out of the work. It should only take 10 seconds or less for the circuit breaker to reset, then you can turn the motor on and start the cut again, this time putting a little less stress on the motor. If you leave the tool engaged in the part and the power on, when the circuit breaker kicks back on, the motor must start under load. This can be very hard on your motor.

Remember that the circuit breaker turns the speed control off, which turns off the motor. If power were to be applied to the speed control with the motor disconnected, it could damage the speed control.

Thermal protection is built into your motor to insure it is not damaged by overloading. Use good common sense when operating the motor for years of trouble-free operation.

HIGH SPEED SPINDLE OPERATION

A special pulley set is available that turns the spindle at up to its maximum rated capacity of 10,000 RPM. See P/N 4335.

OPERATION OF THE MOTOR AND ELECTRONIC SPEED CONTROL

The lathe is supplied with an electronic speed control that produces a comprehensive range of speeds suitable for all operations. Special circuitry designed into the DC motor speed control automatically compensates for speed changes due to increased load. If the spindle RPM drops noticeably when cutting, you are taking too heavy a cut. The speed range of the spindle using the speed control is from 70 to 2800 RPM. This is achieved without the inconvenience of changing belt positions or gear ratios as is often the case with other designs. A second belt position is offered as an additional feature to provide extra torque at low RPM for larger diameter parts should your job require it.

To operate the motor, turn the speed control knob counterclockwise as far as it will go. Then turn the toggle switch to "ON" and select the speed by turning the speed control knob clockwise.

Motors are Pre-tested at the Factory

Your new motor should run smoothly the first time you use it, as it has been "run in" for about an hour before being shipped to you. Despite our secure packaging, there have been cases where extremely rough handling by a shipper has damaged the magnets in the motor. If the motor does not run when plugged in, turn the motor by hand. If it does not turn smoothly, it may have been damaged in shipment. Call Sherline for instructions on making a damage claim with the shipper. Do not attempt to repair the motor yourself.

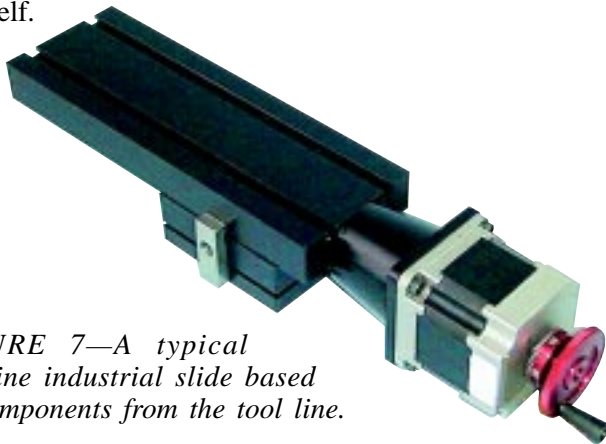

FIGURE 7—A typical Sherline industrial slide based on components from the tool line.

INDUSTRIAL APPLICATIONS FOR SHERLINE COMPONENTS

For many years, Sherline spindles, slides and motor units have been especially popular with designers of custom tooling for small industrial applications because of the low cost and the large number of Sherline accessories that fit the spindle. In fact, we use them in our own production facility for a number of operations. Sherline is now offering a complete line of components made specifically for the production tooling designer. As you would expect, the size range is best suited for smaller operations, but if your needs fit within the specifications of Sherline components, excellent design results can be achieved. For more information on products from Sherline's Industrial Products Division, see our web site at www.sherlineIPD.com.

MOUNTING THE HEADSTOCK TO THE LATHE OR MILL

You may notice that the post onto which the headstock mounts is a loose fit where it projects from the lathe bed or column saddle. This is normal, and the diagram in Figure 8 will help you understand how it works.

The screw in the front center of the headstock has a cone point. The pivot pin has a tapered slot with a corresponding angle. When the screw is tightened, its angled face engages the groove, and, because the pivot pin can not come up, it draws the headstock down into position, clamping it into place. If the pin were rigid, it could keep the headstock from pulling down squarely.

The headstock is aligned with the lathe bed or column saddle by means of a precision ground key that fits into keyways in both parts. It is not square in cross section so it will fit in only one direction. Push the headstock firmly against it as you tighten the hold-down screw. The mill column saddle has two keyways milled into it so the headstock can be mounted in conventional fashion or at a 90° angle for horizontal milling.

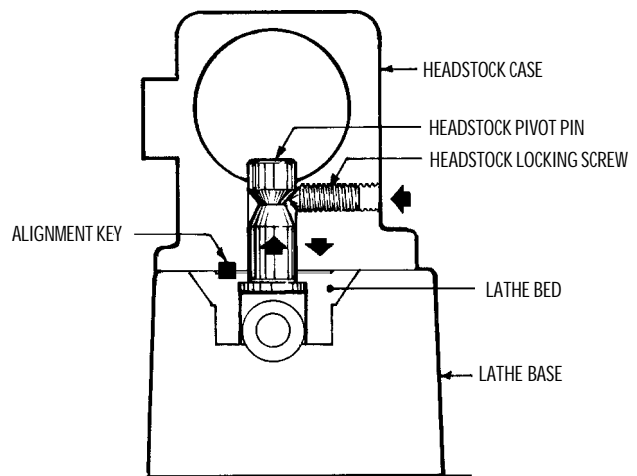

FIGURE 8—A cross-section of the headstock showing the pointed locking screw

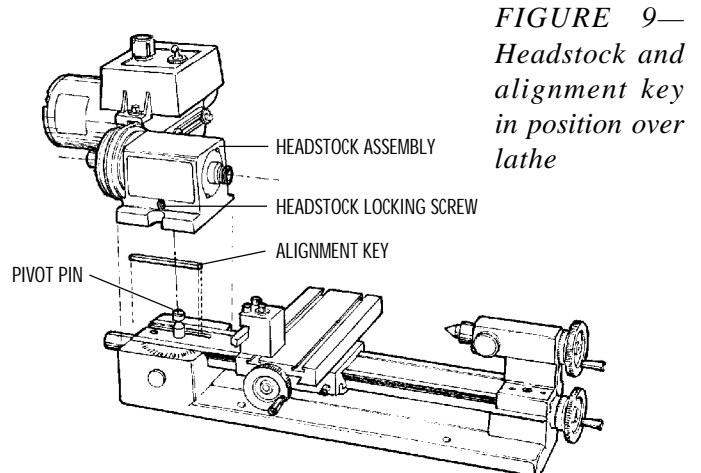

FIGURE 9—Headstock and alignment key in position over lathe

CAUTION! Always make sure the key, slot and mating surfaces are free from dirt and chips before locking down the headstock.

NOTE: Alignment keys are fitted to each machine. If you have more than one machine or component that uses an alignment key, try not to mix them up.

Removing the headstock alignment key permits the headstock to be mounted in positions other than square. This allows you to mill parts at an angle or turn tapers on the lathe. When using the lathe or mill without the alignment key, keep cutting loads light.

MOUNTING THE LATHE AND MILL TO A BOARD

Mounting the lathe to a board is necessary because of the narrow base. This keeps the machine from tipping. We recommend mounting the lathe on a piece of pre-finished shelf material, which is readily available at most hardware stores. (See Figure 11 for sizes.) The machine can be secured to the board using four 10-32 screws with washers and nuts. Lengths should be 1-1/2" for short bed lathes and 1-7/8" for long bed lathes. Rubber feet should be attached at each corner on the bottom of the mounting boards. They are also readily available in hardware stores.

This arrangement gives the machines a stable platform for operation yet still allows for easy storage. The rubber feet help minimize the noise and vibration from the motor. Mounting the tool directly to the workbench can cause vibration of the bench itself, which acts as a "speaker" and actually amplifies the motor noise. Bench mounting also eliminates one of the best features of Sherline machines...the ability to be easily put away for storage.

FIGURE 10—Machines mounted to a base board for stability.

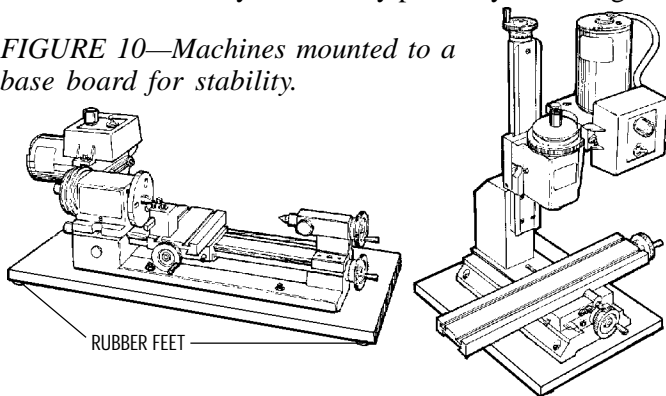

The mill may be mounted in a similar manner on a 10" x 12" to 12" x 24" pre-finished shelf board with rubber feet using 10-32 x 1" screws to attach the mill to the board.

REMEMBER: DO NOT LIFT YOUR MACHINE BY THE MOTOR! Carry the machine by lifting under the base or by the mounting board.

To keep your Sherline tools clean, soft plastic dust covers are available. The lathe cover is P/N 4150 for the Model 4000/4100 and 4500/4530 short bed lathes and P/N 4151 for the Model 4400/4410 long bed lathe. A mill dust cover is available as P/N 5150 for 5000-series mills and P/N 5151 for 2000-series 8-direction mills.

CONVERTING MACHINES FROM INCH TO METRIC OR VICE VERSA

All Sherline tools and accessories are manufactured in your choice of inch or metric calibrations. Converting a lathe or

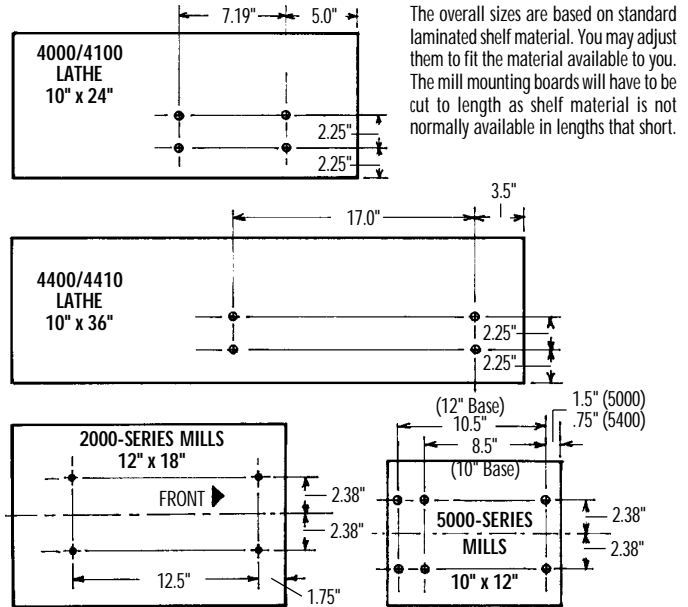

FIGURE 11—Plans for mounting board hole patterns. Confirm actual dimensions from your lathe or mill before drilling.

mill from one measurement system to the other is possible, but it takes more than changing the handwheels. The leadscrews, nuts and inserts must also be changed. A look at the exploded views of the machines on pages 42 through 44 will show which parts need to be purchased. (Look for parts that have both a metric and inch version in the parts listing.) Conversion kits with all the necessary parts are available. If you are a good mechanic, you can do the conversion yourself, or you can return your machine to the factory for conversion.

ADJUSTMENTS

TWO-SPEED PULLEY

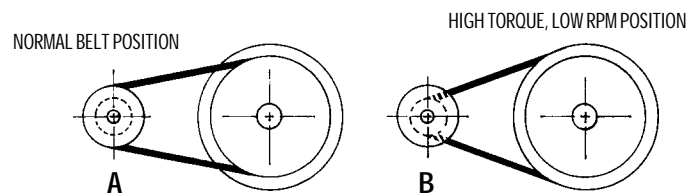

FIGURE 12—The two pulley positions. Position A is the conventional setting, position B offers more torque at low RPM when turning large diameter parts.

The normal pulley position, which is placing the belt on the larger motor pulley and smaller headstock pulley, will suffice for most of your machining work. Moving the belt to the other position (smaller motor pulley, larger headstock pulley) will provide additional torque at lower RPM. It is particularly useful when turning larger diameter parts with the optional riser block in place. To change the pulley position, remove the speed control hold-down screw and pivot the speed control housing up out of the way. Remove the mounting plate from its position on the rails of the two halves of the

belt guard housing. Loosen the two nuts that hold the motor to the motor mounting bracket and take the tension off the belt. With your finger, push the belt off the larger diameter groove of the pulley and into the smaller one. (Depending on which way you are changing it, this could be either the motor or spindle pulley.) Then move the belt to the larger diameter groove on the other pulley, and rotate the headstock by hand to get it to seat. Push the motor outward on the motor mounting bracket to put the proper tension on the belt, and retighten the two motor mounting screws. Now you can replace the mounting plate, pivot the speed control back down, and refasten it. Moving the belt back to the other position is simply a reverse of the above procedure.

SPINDLE PRELOAD ADJUSTMENT

If any end play develops in the main spindle, it can be easily eliminated by readjusting the preload nut. (See part number 40160 in the exploded view.) When the headstocks are assembled at the factory, the preload nut is adjusted to .0002" (.005 mm) of end play. This is controlled by the outer races of the bearing being held apart by the headstock case and the inner races being pulled together by the preload nut. This setting was determined through experience, and, like everything in engineering, it is a compromise. If the machine is only to be run at high-speed, this setting may be too "tight." The headstock will run fairly warm to the touch normally, but extended periods of high speed operation may bring about excessive temperature. The headstock should not be too hot to touch. If this is your case, the preload tension may be reduced slightly.

To change the adjustment, remove the spindle pulley, loosen the set screw in the preload nut and back the preload nut off 4° of rotation (counterclockwise). The bearings are lightly pressed into the case, so the inner race will not move without a sharp tap with a plastic mallet to the end of the spindle where the pulley is attached.

If you find your bearings are set too loose, you may want to take up on the end play. You can check them with an indicator or by spinning the spindle without the motor belt engaged. If the spindle spins freely with a chuck or faceplate on it, it is too loose for normal work. Adjust the preload nut until it turns only about one and a half revolutions when spun by hand.

GIB ADJUSTMENT (Lathe and Mill)

Tapered gibs are fitted to the mill headstock, saddle and table and to the lathe saddle and crossslide. Correct adjustment of the gibs will ensure smooth and steady operation of the slides. The gib is effectively a taper with an angle corresponding to the one machined into the saddle. It is held in place by an "L" wire gib lock that is secured with a locking screw. It is adjusted by loosening the gib locking screw and pushing the gib inward until "play" is removed. After adjusting, retighten the locking screw. Milling operations require a tighter adjustment of the gibs than lathe operations.

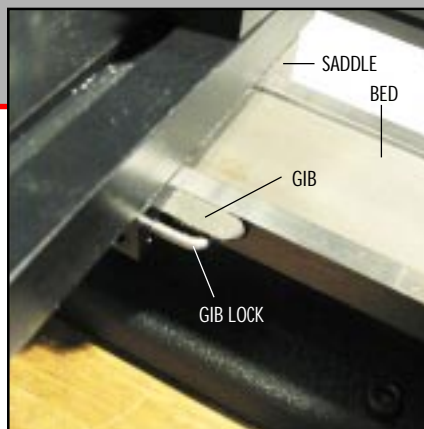

FIGURE 13—
Adjusting the gibs

BACKLASH ADJUSTMENT (Lathe and Mill)

Backlash is the amount the handwheel can be turned before the

slide starts to move when changing directions. This is a fact of life on any machine tool, and on machines of this type it should be about .003" to .005" (.08 mm to .12 mm).

Backlash must be allowed for by feeding in one direction only. Example: You are turning a bar to .600" diameter. The bar now measures .622" which requires a cut of .011" to bring it to a finished diameter of .600". If the user inadvertently turns the handwheel .012" instead of .011", he couldn't reverse the handwheel just .001" to correct the error. The handwheel would have to be reversed for an amount greater than the backlash in the feed screws before resetting the handwheel to its proper position.

Backlash on the X- and Y-axes of the mill may be reduced to a minimum by adjustment on the anti-backlash nuts. These nuts are located on the handwheel ends of the mill saddle. The nuts are secured by button head screws that hold a star gear that interlocks with teeth on the nut.

To adjust backlash, simply loosen the button head screw that locks the star gear. Rotate the anti-backlash nut clockwise on the X-axis and counterclockwise on the Y-axis until snug. Retighten the button head screw while pushing the gear toward the nut. With the anti-backlash nuts properly adjusted, the leadscrews should turn smoothly and have no more than the proper .003" to .005" of backlash.

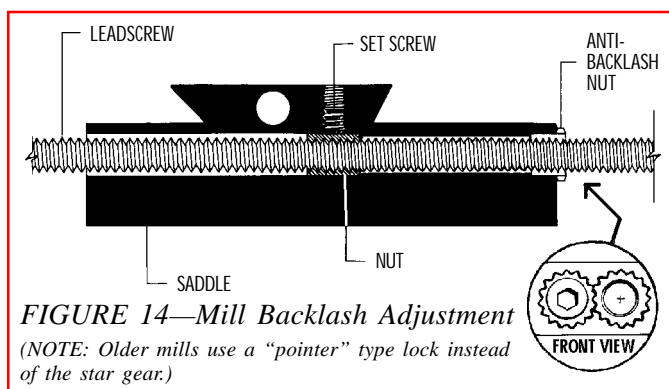

FIGURE 14—Mill Backlash Adjustment
(NOTE: Older mills use a "pointer" type lock instead of the star gear.)

HANDWHEEL ADJUSTMENT (Lathe and Mill)

The handwheels are secured to their corresponding leadscrew shafts by a small set screw in the side of the handwheel base. Check them periodically to make sure they have not been loosened by vibration. On the adjustable "zero" handwheels, you must first release the rotating collar by loosening the locking wheel. Then rotate the collar until you can see the set screw through the small hole in the side of the collar and adjust the screw as necessary.

If a handwheel has been removed, when reinstalling it, make sure it is pushed up tightly against its thrust collar before tightening the set screw. Push the appropriate table or saddle toward the handwheel to remove any excess play before tightening. For the mill Z-axis, lift up on the headstock to remove play.

If excessive backlash develops at the handwheel and thrust collar junctions, adjust by first loosening the handwheel set screw. Index (rotate) the handwheel so the set screw tightens on a different part of the shaft. (If you don't, it may tend to keep picking up the previous tightening indentation and returning to the same spot.) Push the handwheel in tightly while holding the saddle and retighten the handwheel set screw.

SADDLE NUT ADJUSTMENT (Lathe and Mill)

Both the lathe saddle and mill column saddle are connected to their respective leadscrews using a similar brass saddle nut (P/N 40170/41170 or 40177/41177). The saddle should first be positioned at the end of its travel as close to the handwheel as possible. A socket head cap screw attaches the saddle nut to the saddle, while two set screws align the nut to the leadscrew. Loosen the cap screw, bring each set screw into light contact with the saddle nut and retighten the cap screw. If binding occurs, readjust the set screws.

NOTE: The mill column saddle nut differs from the lathe leadscrew saddle nut in that it includes a spring-loaded ball that engages a detent in the saddle locking lever. See page 36 for details on use of the saddle locking lever.

ADJUSTMENT AND USE OF THE TWO-PIECE TAILSTOCK

The brass tailstock gib should be adjusted so that it is equally tight at both ends and slides easily on the bed dovetail when the adjustment screw is loosened. As the brass gib wears, any play that develops can be adjusted out by loosening the two set screws, readjusting the two button head screws and then relocking the set screws. To lock the tailstock in place on the bed, tighten the center socket head cap screw. Do not overtighten.

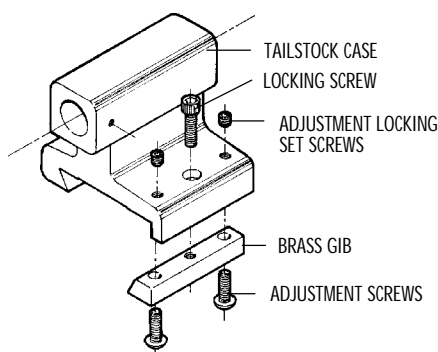

FIGURE 15—*Components of the tailstock case and adjustable gib*

ALIGNING THE LATHE HEADSTOCK AND TAILSTOCK

The versatile feature of Sherline machines that allows the headstock to be removed or rotated for taper turning and angle milling keeps us from being able to lock the headstock in perfect alignment. Precision ground alignment keys and accurate adjustment at the factory, however, make the machines highly accurate. In standard form, alignment should be within .003" (.08 mm). This should be more than acceptable for most jobs you will attempt.

Only someone new to machining would talk about “perfect” alignment. Machinists speak instead in terms of “tolerances,” because no method of measurement is totally without error. We believe the tolerances of your machine are close enough for the work for which it was intended; however, for those searching for maximum accuracy, here are some tips for maximizing the accuracy of your machine. Loosen the headstock, push it back evenly against the alignment key and retighten. This will maximize the accuracy of the factory setting. To achieve greater accuracy, you will have to be willing to sacrifice one of the better features of your lathe or mill; that is, its ability to turn tapers and mill angles in such a simple manner.

HEADSTOCK—If you choose total accuracy over versatility or need it for a particular job, proceed as follows. Remove the headstock and clean any oil from the alignment key and slot and from the area of contact between bed and headstock. Replace the headstock, pushing squarely against the key and retighten. Take a light test cut on a piece of 1/2" to 3/4" diameter by 3" long aluminum stock held in a 3-jaw chuck. Use a sharp-pointed tool to keep cutting loads low so as not to cause any deflection of the part. Measure the diameter of both machined ends. If there is a difference, the headstock is not perfectly square. Now, without removing the key, tap the headstock on the left front side (pulley end) if the part is larger at the outer end. Tap on the right front side (chuck end) if the part is larger at the inner end.) You are trying to rotate the headstock ever so slightly when viewed from the top until the machine cuts as straight as you can measure. There should be enough movement available without removing the key, as its factory placement is quite accurate.

Take another test cut and remeasure. Repeat this procedure until you have achieved the level of perfection you seek. Then stand the lathe on end with the alignment key pointing upward and put a few drops of LocTite™ on the joint between key and headstock. Capillary action will draw the sealant in, and when it hardens, the key will be locked in place. We prefer this method to “pinning” the head with 1/8" dowel pins, because it offers you the option to change your mind. The headstock can be removed by prying with a screwdriver blade in the slot between the bottom of the headstock and the lathe bed to break the LocTite™ loose should you wish to be able to rotate the headstock again.

TAILSTOCK—To maximize the machine’s tailstock alignment, first make sure that there are no chips caught in the dovetail of the bed and no chips or dents in the taper of your tailstock center. Now put a 6" long piece between centers and take a long, light test cut. Measurements at either end will tell you if you need to use an adjustable tailstock tool holder in the tailstock to achieve better tailstock alignment. We manufacture adjustable tailstock tool holders (P/N 1202, 1203, 1206) and an adjustable live center (P/N 1201) that can help you attain near perfect alignment at the tailstock should your job require it. Instructions for their use are included with each item.

Remember that unless you drill very small holes (less than 1/64") or turn a lot of long shafts, you are giving up a very useful feature to solve a problem which can usually be handled with a few passes of a good mill file. The inaccuracy inherent in any drill chuck is such that perfect machine alignment is meaningless unless you use adjustable tailstock tool holders.

SQUARING UP YOUR MILL

The following tips are taken from the Model 2000 mill instructions. Though the 8-direction mill is shown in the examples, the same procedures would be used for aligning the 5000-series mills, or any mill for that matter.

FIGURE 16—The axes of movement of a Sherline 8-direction mill. Table left/right movement is referred to as the X axis. Table in/out movement is the Y axis.

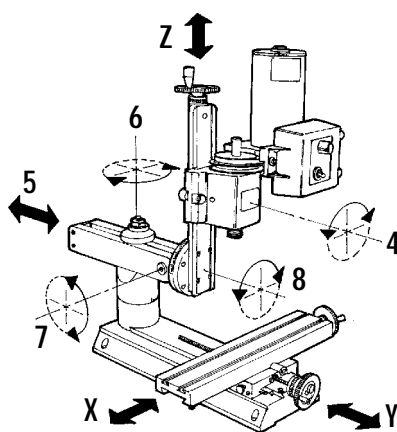

Headstock up/down movement is referred to as the Z axis. The headstock can also be rotated on its saddle on Sherline mills. The four additional movements available on the model 2000 mill are also shown above.

Determining the level of accuracy you really need

Squaring up a multi-direction mill can be a chore if you want "perfection." It is best to determine how accurate the setup must be before you start. The larger a close tolerance part is the better the setup required. An error of .001" (.025 mm) per inch (25.4 mm) would be a very small error on a part .4" (10 mm) long. However, a part that is 5" long would have an error of .005". The type of machining that is going to be performed also has a bearing on the quality of the setup. As an example, a drilled hole doesn't usually require the quality of setup that would be used for a bored hole, (assuming the hole is being bored for accuracy rather than for lack of a drill of the proper size). The amount of work that will be done with the setup should be considered too. If your setup is just to do one particular job you only have to set it up close enough to do that job. If the setup will accommodate future operations as well, it should be adjusted to the tolerances of the most critical job. For example, squaring up a mill and vise to work on a number of precise parts is worth more of your attention than setting up to drill one clearance hole in a non-critical part.

Limitations of the production process

Before starting you should realize that these mills are relatively inexpensive machine tools. They have accurately milled slides but the surfaces are not ground. To increase the accuracy of a Sherline tool only a percentage point

would dramatically increase the price. We try to give a customer what we consider "the most bang for the buck."

Why aren't there alignment pins to square up the machine?

If you are a novice to machining, you probably believe a machine should be designed so that a couple of pins could be dropped into holes, squaring up the machine and eliminating this whole process. After all, that is the way they do it with woodworking machinery. The truth is the tolerances that work well for wood cutting tools simply aren't accurate enough for most metalworking tools. You just can't hold the tolerances required with "pins." When they fit tight enough to lock the head square to the table you can't remove them to do work that isn't square. They become more of a problem than the problem they were installed to eliminate. For example, an alignment or assembly error of .010" in a wooden kitchen table will never be noticed. Usually the floor it sits on is not even flat. It would be a waste of time and effort to make it more accurate than it has to be. On the other hand, a cylinder that has been bored out of square with the crankshaft in an automobile engine could wear the entire engine at an alarming rate. The piston goes up and down a million times in a normal day's use. The additional cost in fuel and shortened life demands accuracy. Your Sherline mill should be adjusted and aligned to the degree of accuracy demanded by the particular job you are attempting to do.

Start by getting the column close to square with the table

ALL SHERLINE MILLS...The first place to start is to get the column approximately square with the table using the pointers and laser engraved scales on the machine. The first time you set it up you will have to use a machinist's square on the side-to-side column rotary adjustment as the pointer will not have been "zeroed in" yet. None of these adjustments must be extremely precise at this point because a finger type dial indicator will be used to make the final adjustments later. Remove the headstock/motor/speed control unit from the saddle. Place a machinist's square on the table and line up the front of the saddle to get the column approximately square front to back. Then line up on the right side of the saddle to get the column approximately square side to side. Reinstall the headstock assembly.

Check for any built-in error in your machine

ALL SHERLINE MILLS...(See Figure 17.) To check the built-in error of the machine use a dial indicator mounted in the spindle. Move the table under spindle with the Y-axis handwheel and note the error. This error will usually be around .001" to .002" (.05 mm) in 3" (76 mm). (Remember the components are not precision ground, they are precision milled.) When squaring the head later on this error should be accounted for. Remember you are squaring the head and spindle to the base of the machine where the saddle travels, not the surface of the table itself. The head doesn't have to be square for this operation as long as you don't rotate the spindle since you are only checking for square in one direction.

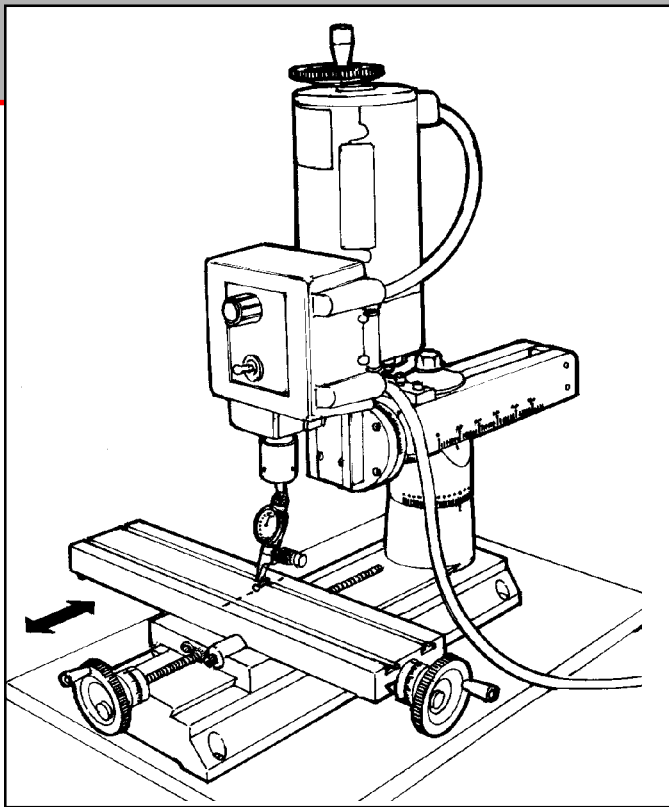

FIGURE 17—Checking for built in error in the table travel along the Y-axis

Squaring up the column

MODEL 2000 MILLS...(See Figure 18.) The next decision to make is where the spindle is to be located. With all the adjustments that can be made with the 8-direction mill you'll probably start with the spindle located near the middle of the X/Y table movements. Something that isn't too obvious should be considered now. If the ram (the two-bar slide that allows you to move the head in or out and left or right) isn't square with the X-axis, the rotating column calibrations will have an error. To square up the ram, mount a dial indicator to the worktable and move the X-axis back and forth while reading the left and right surfaces of the column bed near the bottom. This only has to be done if you will be rotating the column and want to be able to rely on the angle graduation readings. Once set, lock the ram in place with the flange nut. Now you can scribe a line on the column base opposite the "zero" mark for future reference as shown in Figure 18.

MODEL 5000-SERIES MILLS...Though the column ram does not rotate on the 5000-series mills, its squareness can still be checked in the same manner if desired. The factory alignment of the holes is quite accurate, but a small amount of adjustment is available by loosening the two screws that hold the column base to the bed and pressing the base to one side or the other while retightening.

Squaring the column with the X-axis

MODEL 2000 MILL OR 5000-SERIES MILLS WITH OPTIONAL ROTARY COLUMN ATTACHMENT...(See Figure 19.) The column should next be squared with the X-axis. This is accomplished with an indicator mounted in the spindle. Have the four socket head cap screws used to clamp the column rotation tight enough to keep the column from rotating, but not so tight that you can't move it with a

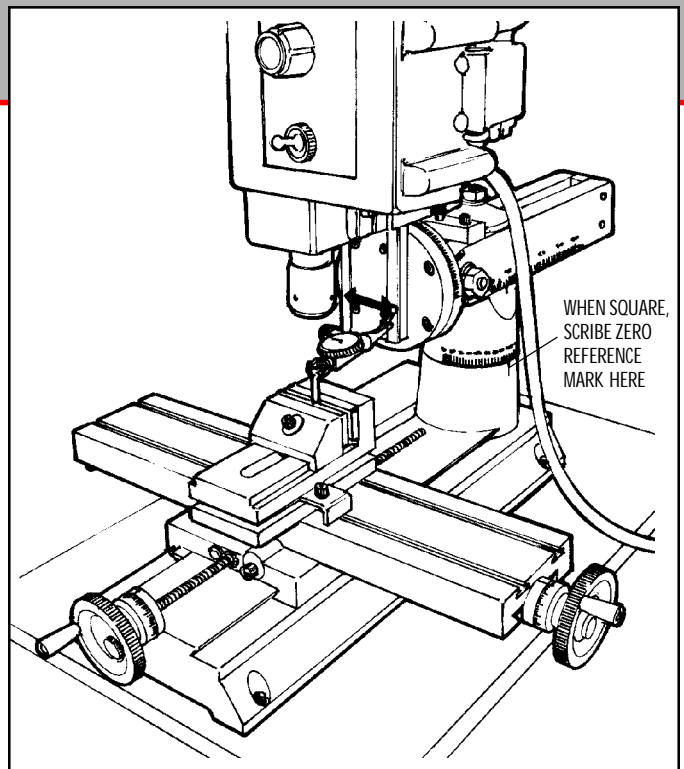

FIGURE 18—Squaring up the ram parallel to the Y-axis on the 2000-series mill. The indicator can be held with a chuck on the table or a mill vise as shown here. When square, tighten the nut on top of the column. 5000/5400-series mills can be adjusted slightly by loosening the two bolts that hold the column base in place, twisting the column slightly and retightening the bolts.

light tap from a plastic mallet to the column bed. Because the axis that allows you to tilt the column in and out hasn't been squared yet you should only read the indicator at the same Y-axis location on the worktable that you used before. Offset the indicator at an angle in the spindle so that when the spindle is rotated it describes about a 2" to 3" circle on the table. Take readings at the extreme left and right positions. Adjust the column with light taps until there is little difference in the readings at either extreme. I wouldn't try to get it perfect yet, just close enough so there isn't a gross error.

Hint: To keep the tip of the indicator from falling into the T-slots, some machinists keep a large ball bearing on hand. The two surfaces of a precision bearing are generally parallel. The bearing is placed on the mill table centered on the spindle and the indicator is run around the surface of the bearing race, which provides a round, flat, parallel surface for the tip of the indicator to run against.

MODEL 5000-SERIES MILLS...This axis is not adjustable on the 5000-series mills, but it can be checked in the same manner. Again, factory alignment should be quite good, but a slight amount of adjustment can be obtained by loosening the four screws that hold the column to the base and pressing the column to one side or the other while retightening.

Squaring the column with the Y-axis

MODEL 2000 MILLS...(See Figure 20.) Loosen the flange nut on the horizontal pivot pin just enough so that the column

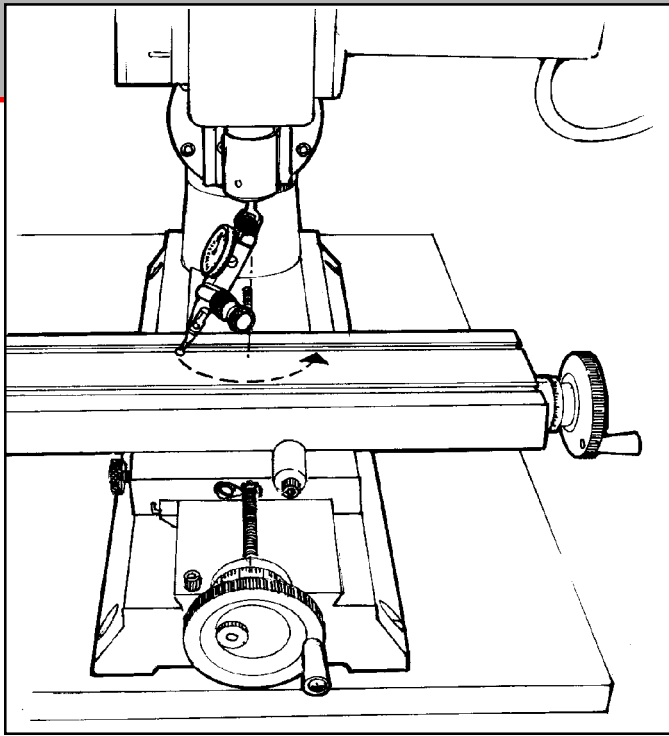

FIGURE 19—Squaring the left to right rotation of the column with the X-axis

can be moved using the adjustment screw in the alignment block but there is no slop in the assembly. The tilt is harder to set because the spindle doesn't rotate at the pivot point, but once you understand this, the task becomes simpler. This is explained in the example that follows. The alignment block adjustment screw helps make fine adjustments in this direction easy. With the block in place and the flange nut loose, the entire assembly is kept from falling forward by the adjusting screw. This block can be left in place unless the ram is completely retracted or the column is tilted back at an angle that interferes with the block. With the indicator still held in the spindle, take readings parallel with the Y-axis near the front and rear edges of the table. Raise or lower the column with the alignment block adjusting screw until the readings are the same front and rear. Remember the location of the pivot point as you take these measurements and allow for it. (See example below.)

MODEL 5000-SERIES MILLS... This axis is not adjustable on the 5000-series mills, but it can be checked in the same manner. Again, factory alignment should be quite good, but a slight amount of adjustment can be obtained by loosening the two screws that hold the column to the base and shimming the column at the front or back with thin metal shim stock* as needed. Recheck your X-axis alignment after shimming.

*Hint: Shim stock can be purchased from most tooling supply catalogs. If you don't have metal shim stock available, cigarette paper or business card stock can be used as a temporary substitute depending on thickness needed.

Example:

If the indicator reading is larger at the front of the table than the back, then that means the column must be tilted back. Say your reading is "0" at the back and .010" (.25 mm) at the front. If you tipped the column back until the indicator read zero at the front, the reading at the back

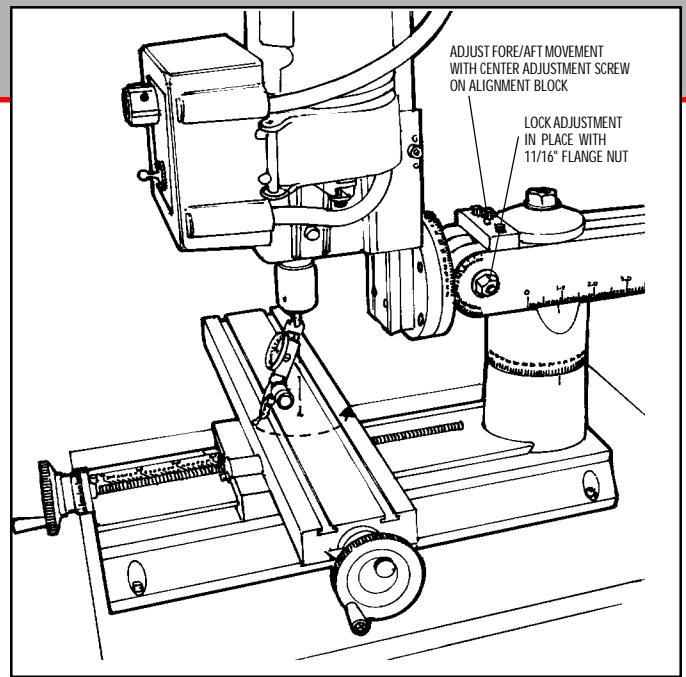

FIGURE 20—Squaring the fore and aft pivot movement of the column with the Y-axis. (See the hint in the section on squaring the X-axis above for a way to keep the tip of the indicator from dropping into the T-slots.)

would not remain at "0" but would now be a negative reading. This is caused because the pivot point is located far enough behind the spindle so that both front and rear measuring points are still in front of it. Swinging the column back actually raises both points. The front point raises more than the back point, but both do go up. You will have to keep tilting the column back and measuring until you get the same reading front and back. This may require more movement than you first thought based on the difference between the initial measurements.

Fine tuning the headstock alignment

ALL SHERLINE MILLS... It is time to make the final adjustments to the rotating column, but first I'll add a little more confusion to your life. Remember when I said that alignment pins are somewhat useless to line up a machine? Well, as much as I hate to admit it, in a sense we already have one. It is the alignment key that holds the headstock assembly square to the column saddle, which is mounted on the column bed. Removal of this key is what allows you to pivot the headstock on the Sherline lathes and mills. It is one of the features that make our machines easy to use, versatile and very adaptable. It is also another thing you have to consider when searching for "perfect" alignment. If you have more than one key, try not to mix them up because they are matched during assembly to fit as closely as possible. I have found the best way to deal with this potential problem is to push the head square against the key before tightening the cone point screw that locks the headstock in place. If you ever want to check alignment of the key to the column bed, mount a dial indicator in the spindle. Raise and lower the head while reading the vertical edge of a precision square. (See Figure 21.) Adjust the rotating column until there is no error as the indicator moves up and down the square. Now read the table with the indicator. If the slot and key are perfect there shouldn't be

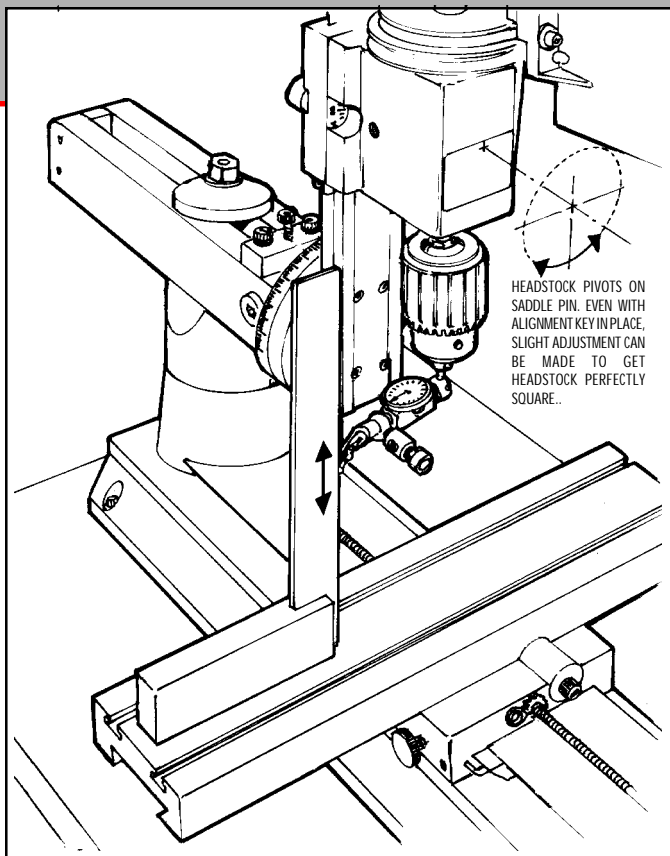

FIGURE 21—Fine tuning the headstock rotation alignment with a machinist's square and dial indicator. The headstock pivots on the saddle pin. Even with the alignment key in place, slight adjustment can be made to get the headstock perfectly square.

any error, but in most cases there will be a small amount. This can usually be eliminated by taking advantage of what play does exist in the alignment key and slot. With the cone point set screw loosened slightly, tap the headstock with a plastic mallet to take out play in the direction you want to go. Then retighten the set screw.

Making final adjustments

The rotating column and tilting adjustments can be finalized so the indicator reads “0” as the spindle is rotated, however the error we measured when checking the table flatness could be accounted for now if need be. If the pointer on the back of the rotary column disk doesn't line up with the zero mark, loosen the screw holding it in place and reset it to indicate zero for future reference. (Model 2000 mills and 5000-series mills with rotary column attachment only.)

Your machine is now “indicated in” and ready to use. As you get a feel for your machine and go through this adjustment procedure a few times, the time it takes to get good results will decrease. Being able to accurately indicate in a mill is one of the skills that must be developed by any machinist who plans on making accurate parts. Though the adjustments on larger machines may be made in slightly different ways, the skills and procedures you learn here can be applied to other machines as well.

Using the column spacer block

MODEL 2000 MILLS (Standard)...In normal use the column spacer block will not be required. However, if you are working on a larger part or your setup requires more

clearance under the swing arm, the spacer block can be installed to raise the column an additional two inches. (Installation will be made easier if you first remove the headstock/motor unit to reduce the weight of the column.) To install the spacer block, remove the flange nut on top of the column hold-down bolt, and lift off the hold-down washer so that the entire column top and swing arm assembly can be lifted off of the hold-down bolt. Screw the extension bolt onto the end of the column bolt and tighten with an adjustable wrench. Slide the column spacer over the bolt and reinstall the column top and swing arm assembly. Reinstall the headstock/motor unit.

NOTE: The column spacer block is included as standard with the Model 2000 mill. It is optional at extra cost on all mill column upgrades and 8-direction vertical milling columns and upgrades.

MODEL 5000 AND 5400 MILLS (Optional)...There is now an optional column spacer block available for use with the standard mill column. It is P/N 1300 and includes longer bolts needed to attach the column to the base through the spacer block. The spacer block will add 2" of additional distance between the spindle and the table. If you simply need more travel, there is also an optional 15" column bed (P/N 45260) and matching leadscrew (P/N 45270/45280), allowing your column to be converted from the standard 11" height to add four more inches of Z-axis travel.

Working with setups that require extremely low or high column travel

MODEL 2000 MILLS ONLY...An upgrade to the Model 2000 mill was introduced in March, 1999. It adds 1.6" of travel to the lower end of the Z-axis movement so that end mills can be brought down below the surface of the table for working on the edge of parts. This travel extension is now standard on all Model 2000 mills. The headstock may be lowered even more by placing the column top (P/N 56550) above the swing arm instead of below it. Remove the flange nut, hold-down washer and swing arm. Place the swing arm over the hold-down bolt directly on top of the column base (P/N 56660). Place the column top back onto the hold-down bolt upside down and replace the hold-down washer and flange nut. Although you cannot use the alignment lines to help square up the head, this makes for a very strong and stable setup. In most cases the new travel extension will make this procedure unnecessary.

Should you wish to work on extremely tall setups that combine several holding devices (i.e., a chuck on top of a rotary table on top of a tilting angle table) you can extend Z-axis travel on the top end by either adding an additional spacer block to the column or by removing the saddle travel extension and attaching the saddle directly to the saddle nut as is done on standard Sherline mills.

Using the saddle locking lever

ALL SHERLINE MILLS...Along with the travel extension, a new saddle locking lever was installed to replace the old saddle friction lock used prior to 2/99. This new locking

lever is standard on all non-CNC-ready mills and vertical milling columns as of that date. This lever is located on the Z-axis leadscrew behind the saddle. When turned to the full clockwise position the saddle will move freely. A spring-loaded ball locates in a detent in the bottom of the lever to hold it in this position. To lock the saddle in position, move the lever to the full counterclockwise position. This locks the lever against the saddle nut which prevents the leadscrew from turning. The exploded view on page 43 shows the location of the components.

Engineering compromises

I'm always at odds with myself when I write instructions on complicated procedures like describing the alignment procedure for this mill. By giving you this much information I know that I am making life easier for some customers by answering their questions. At the same time I am probably confusing another customer who would never have asked the question because of the type of work that the mill or lathe is being used for. I don't want to create a customer who spends all his time trying to achieve perfect alignment for work that doesn't require it and ends up never using the machine. Engineering is always a compromise. I deal with this fact with each new product that I design. While our machines aren't accurate enough for some customers, they are still too expensive for others. I hope you are pleased with the new capabilities this multi-direction mill can bring to your shop. I think you will find the combination of features offers a very good machining value.

USE OF CUTTING OILS AND LUBRICANTS

Much can be written about the use of lubricants, but they may usually be dispensed with where production rates are not very important. A small amount of any kind of oil applied with a small brush will be sufficient. Aluminum and its alloys may require the use of cutting oil to prevent the chips from welding to the tool's point. Do not use oils with a low flash point or a bad smell. If desired, a mixture of one part soluble oil to six parts water may be used on steel to assist in producing a smoother finish and reduce tool chatter when parting off. Brass and cast iron are always turned dry. Cutting lubricants should be cleaned off the tools after use.

Cutting oils can be purchased at an industrial supply store. In the past it was sold only in "industrial" quantities that were too large for home shop use; however, several industrial suppliers now sell it in quantities small enough to be practical for the home machinist. Do not use high sulfur pipe thread cutting oil. It is good for hard-to-machine materials, but is so dirty to work with we do not recommend it. We also find some of the cutting fluids used for tapping are too smelly and unpleasant to use for general machining.

The main purpose of using lubricants is to keep the chips from sticking to the cutting tool. When used properly, modern high-speed tool bits are not likely to be affected by heat on the type of work usually done on miniature machine tools.

GENERAL MACHINING TERMS

Two terms frequently used in machining are "feed" and "cut." Reference to the diagrams that follow will show

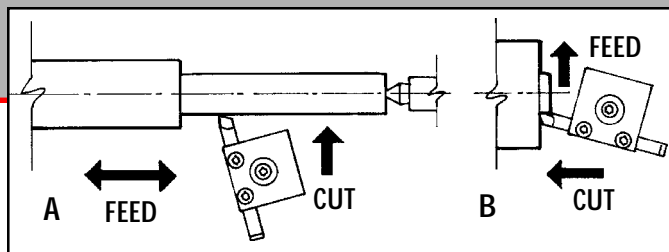

FIGURE 22—Directions of Feed and Cut showing (A) Turning work between centers and (B) Facing off a work piece

what is meant by these terms. Normal turning on a lathe, when used to reduce the diameter of a work piece, involves advancing the cutting tool perpendicular to the lathe bed by an appropriate amount (depth of cut) and feeding the tool along parallel to the lathe bed to remove material over the desired length. (See Figure 22.)

In normal lathe turning, the depth of cut is set by the crossslide handwheel, and the feed is provided by the handwheel on the end of the bed. When facing off the end of a work piece held in a chuck or faceplate, the depth of cut is set by the handwheel on the end of the bed, and the feed is provided by the crossslide handwheel. (See Figure 24.)

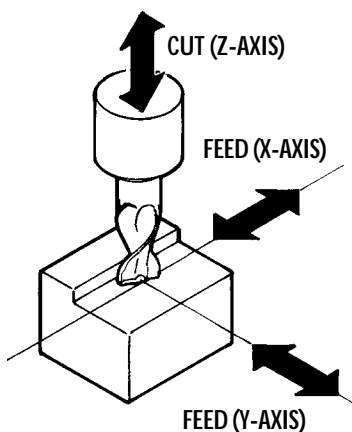

FIGURE 23—Directions of Feed and Cut when working with a milling machine

When using a mill, **cut** is determined by the amount of depth the cutter is set to by the Z-axis handwheel. **Feed** is supplied by either or both the X- or Y-axis handwheels depending on the desired direction of the cut. (See Figure 23.)

GENERAL RULES FOR FEED RATES AND CUTTING SPEEDS

Before attempting to machine any metal, please try to remember this simple rule about machining:

“If the tool chatters, decrease speed and increase feed.”

Understanding this simple rule can save you many hours of grief. When the tool “chatters,” it is not cutting in a continuous fashion. Metal likes to be machined in a way that allows the material to come off in a continuous strip while the tool is in contact with the metal. If the tool is not fed at a rate that is fast enough, the tool skips along the surface, occasionally digging in. The surface of the tool that is doing the most cutting will find a frequency of vibration that is a product of all the variables involved. This can cause anything from a high pitched whine on light, high speed cuts to a resonating racket that can rip the work out of the chuck on heavy cuts. If you maintain the same feed rate and reduce the RPM, the feed will increase because chip will be thicker. (If that sounds wrong at first, think of it this way: At the same feed rate, if you cut the RPM in half, twice as much metal must be removed with each rotation

to get to the end of the cut in the same amount of time. The chip is twice as thick, so the feed is GREATER at lower RPM if the feed RATE stays constant.)

When a tool chatters, it gets dull faster, because it must keep cutting through the previously machined surface that has been “work hardened” by machining. As you can imagine, there are limits to how much you can increase feed rate, so the answer lies in adjusting both speed and feed to achieve the proper cut.

Proper cutting speed is the rate a particular material can be machined without damaging the cutting edge of the tool that is machining it. It is based on the surface speed of the material in relation to the cutter. This speed is a function of both the RPM of the spindle as well as the diameter of the

part or size of the cutter, because, as the part diameter or cutter size increases, the surface moves a greater distance in a single rotation. If you exceed this ideal speed, you can damage the cutting tool. In the lathe and mill instructions, we give some examples of suggested cutting speeds, but what I wanted to get across here is that the damage isn’t a slow process. A tool can be destroyed in just a few seconds. It isn’t a case of getting only one hour of use instead of two. The cutting edge actually melts. If you machine tough materials like stainless steel, you will ruin more tools than you care to buy if you don’t pay a lot of attention to cutting speeds. Charts showing suggested cutting speeds for various materials are included in both the lathe and mill sections that follow.

LATHE OPERATING INSTRUCTIONS

CAUTION!

READ ALL OPERATING INSTRUCTIONS CAREFULLY BEFORE ATTEMPTING ANY MACHINING OPERATIONS.

LEVELING THE CUTTING TOOL

Each type of turning work requires the correct tool for the job. It is important that the cutting tool be sharp and correctly set up in the tool post. The cutting edge of the tool should be exactly level with the center height of the lathe. Check this by bringing the tool tip up to the point of either the headstock center or tailstock center. (See Figure 24A.) We also manufacture a simple tool height adjustment gage that allows you to check tool height at any time by measuring from the table surface. (See Figure 24B.)

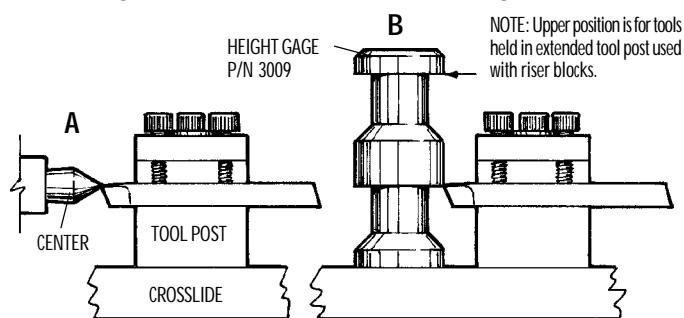

FIGURE 24—Leveling the tool using (A) the tip of a head- or tailstock center or (B) Sherline’s tool height gage P/N 3009.

The standard Sherline tool post is designed to hold common 1/4" square tool bits which have had a few thousandths of an inch (.1 mm) ground off the top edge for sharpening. Loosen the hold-down bolt and slide the tool post as close to the center as possible. The tip of the tool bit may be raised or lowered by sliding a shim* underneath it. The cutting edge must be on center or just below center (0.004" or .01 mm maximum). Ensure that the tool is fixed securely in position by firmly tightening the socket head screws. Try not to have the tool cutting edge protruding more than 3/8" (10 mm) from the tool post.

*NOTE: Thin metal shim stock is available for this purpose. If you don’t have any metal thin enough, a single thickness of paper business card stock will usually do the job. Do not use more than one thickness as it will compress too much. Our optional rocker tool post (P/N 3057) allows this adjustment to be made without shims. It comes standard with the Model 4400/4410 long bed lathe.

INITIAL TEST CUTTING

If you have never operated a lathe before, we suggest that you make a trial cut on a scrap of material to learn the operation of the machine. In a 3- or 4-jaw chuck, secure a piece of round aluminum stock approximately 3/4" (19 mm) diameter and 1-1/2" (38 mm) long. Secure the presharpener 1/4" square cutting tool supplied with the lathe in the tool post, making sure that it is properly positioned. First, turn the speed control all the way counterclockwise, then turn the motor on. Bring the speed up to approximately 1000 RPM (about 1/3 speed). To establish tool position in relation to the work, bring the tool in slowly until it just starts to scribe a line on the work. Crank the tool towards the tailstock until it clears the end of the work. Advance the tool .010" (.25 mm) using the crossslide handwheel (10 divisions on the inch handwheel scale). Using the bed handwheel, move the tool slowly across the work toward the headstock.

Cutting tools used on lathes are designed to remove metal much as paper is removed from a roll. It takes a positive feed rate to accomplish this. If the feed rate isn’t fast enough, it would be similar to tearing an individual sheet of paper off the roll. The results when cutting metal would be shorter tool life, a poor finish and tool “chatter.” Chatter is a function of rigidity, but it is controlled by speed (RPM) and feed rate.

Since you already have a piece of aluminum chucked up, experiment with speed and feed rate. You just took a cut of .010" (.25 mm) and probably noticed that the machine didn’t even slow down in the slightest. Now take a 1/2 inch long cut .050" or 1 mm deep, which is one complete revolution of the handwheel. If you used the sharpened cutting tool

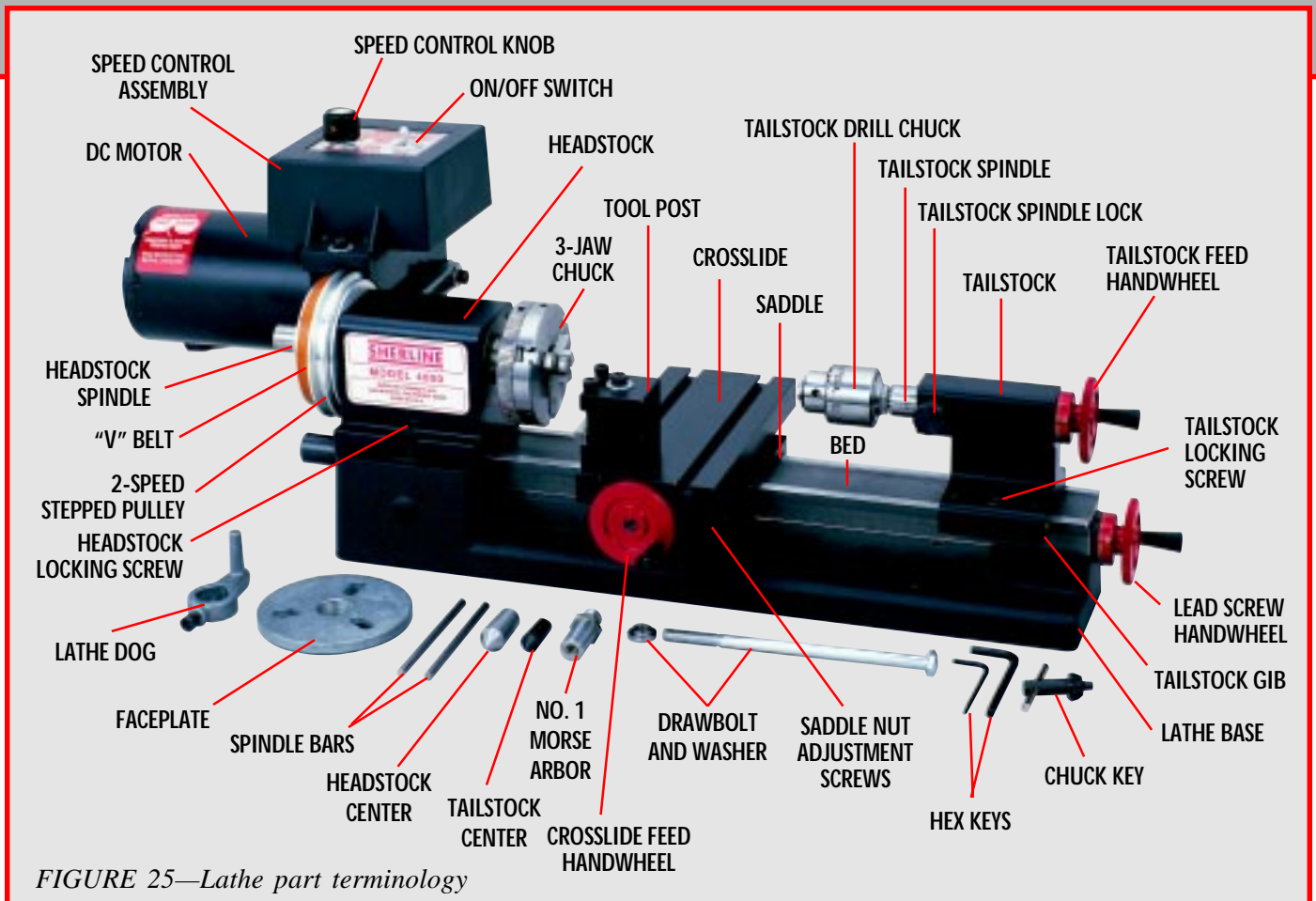

FIGURE 25—Lathe part terminology

that came with your machine, it should have made the cut easily. If the tool “squealed,” reduce the RPM a little and take another .050” cut while feeding the tool faster. You will probably be surprised at how easily your machine takes cuts this heavy.

INDUCING CHATTER AND LEARNING HOW TO OVERCOME IT

To better understand what is going on, we will now purposely try to make the machine “chatter.” Make sure the stock you are cutting is sticking out of the chuck no more than 1 inch (25 mm). Crank the handwheel two turns further in from the last setting which will give you a .100” (100 thousandths of an inch) or 2 mm cut. Set the spindle speed to about 1000 RPM (1/3 speed) and feed the tool slowly into the material. Vary speed and feed until you get a substantial chatter. Without changing the depth of the cut, drop the speed to about 200 RPM and feed the tool into the work with more force. The chatter should disappear. Once you have learned to control chatter by adjusting speed and feed, you will be well on your way to becoming a machinist.

HOLDING THE WORKPIECE

Work can be held between centers, in 3-jaw or 4-jaw chucks, on the faceplate or with a collet. Sometimes it is necessary to use a chuck and center, and, if the work is spinning fast, a live center should be used. (See Figures 26, 27 and 28.)

TURNING BETWEEN CENTERS

This is done by fitting the dog to the work which is to be turned and placing the work and dog between the centers in the headstock and tailstock. The maximum diameter that

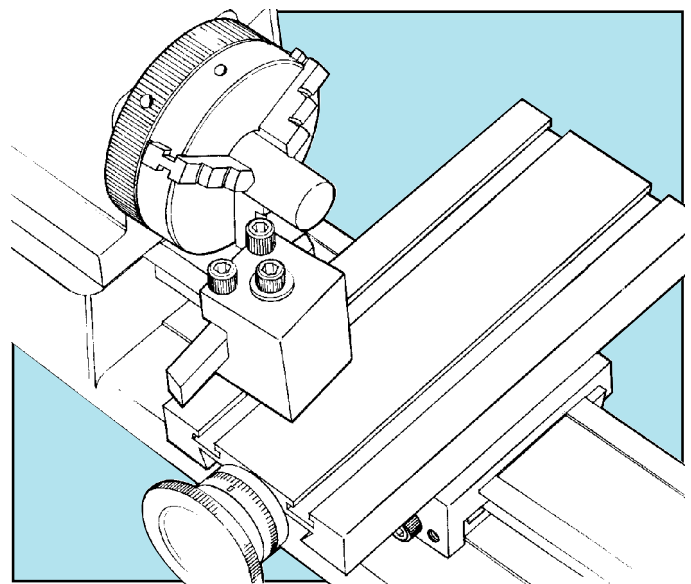

FIGURE 26—Holding a round work piece in a 3-jaw chuck

can be held with the dog is 5/8” (15 mm). (See Figure 28.) The dog is driven by fitting it into one of the faceplate holes. This method of turning is ideal for bar work or turning of steps on a bar. The tailstock center must be greased to prevent overheating. (An optional live center—such as P/N 1191—turning on ball bearings is the solution preferred by most machinists.) The headstock spindle has a #1 Morse taper in the spindle nose. The tailstock spindle has a #0 Morse taper.

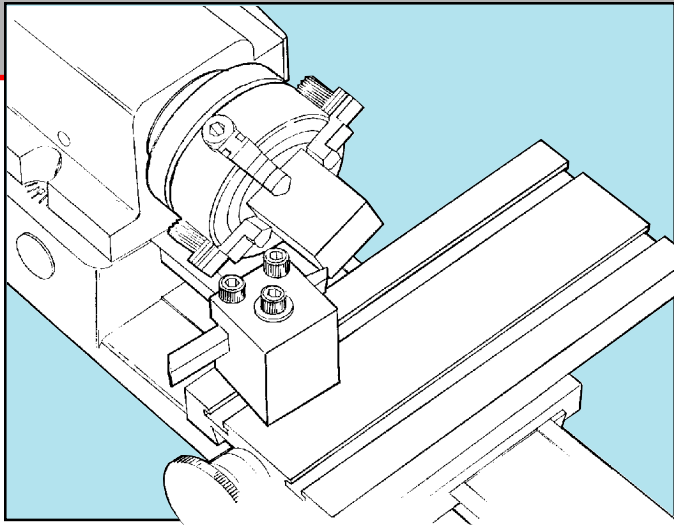

FIGURE 27—Holding a square work piece in a 4-jaw chuck

REMOVING TOOLS FROM THE MORSE TAPERED SPINDLES

Accessories held in the headstock spindle use a Morse #1 taper and can be removed with the use of a knockout rod (not supplied) approximately 3/8" in diameter and 6" long. The bar is inserted through the back of the spindle, and accessories, such as centers, can be removed with a few

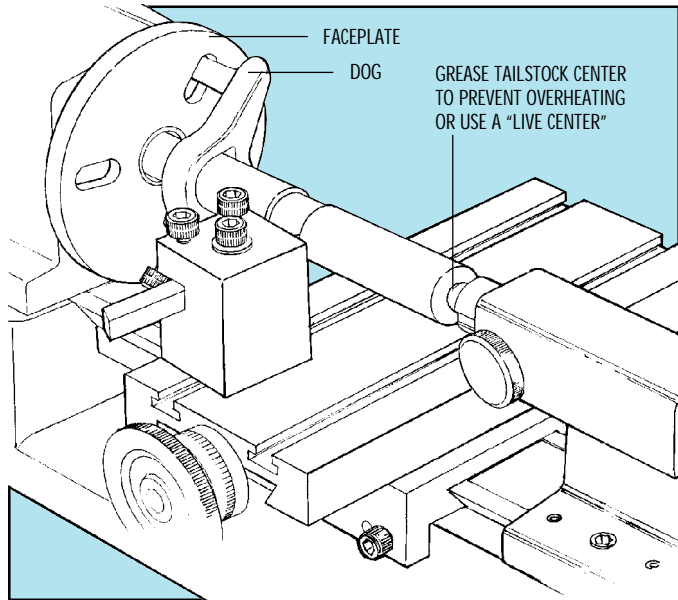

FIGURE 28—Turning between centers with a faceplate and drive dog

taps. Accessories like the drill chuck that are drawn into the spindle taper with a drawbolt are removed by loosening the drawbolt a few turns and then giving the head of the bolt a sharp tap to break the taper loose. The tailstock spindle does not have a through hole and a drawbolt is not used. It is equipped with a Morse #0 taper, and accessories such as drill chucks and centers can be removed by turning the handwheel counterclockwise until the accessory is ejected.

CENTER DRILLING

Because the work turns and the drill does not on a lathe, it is necessary to use a center drill before a standard drill can be used. Due to the flexibility of a standard drill bit, it will

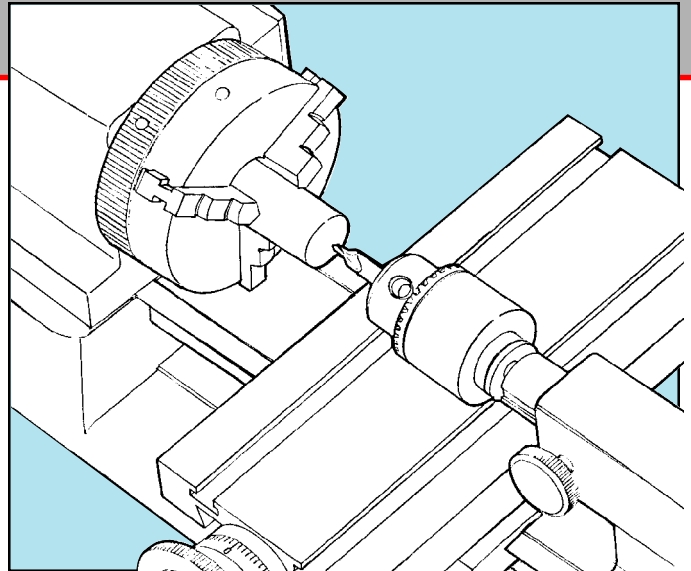

FIGURE 29—Tailstock center drilling. The work turns while the drill is held stationary in the tailstock

tend to wander on the surface of the rotating work, whereas a center drill is designed to seek the center and begin drilling. The 60° point of the center drill makes a properly shaped index hole for the tip of a live or dead center. It also provides an accurate starting point for a standard drill. Cutting oil is recommended for all drilling operations. A center drill should be withdrawn, cleared of chips and oiled several times during the drilling of a hole to keep the tip from breaking off.

For more information, see the chart of commonly available center drill sizes on page 38.

TAILSTOCK DRILLING

Hold the work in a 3- or 4-jaw chuck. If the work is longer than approximately 3" (76 mm), support the free end with a steady rest. Seat the drill chuck's #0 Morse arbor into the tailstock spindle and secure a center drill in the chuck. Adjust the tailstock to bring the center drill close to the work and lock it in position. Turn the tailstock handwheel to bring the center drill forward. After the hole is started with the center drill, switch to a standard drill bit of the desired size to drill the hole. (See page 37 for more on drilling holes.)

The easiest way to center drill the end of a round shaft that has a diameter too large to be put through the spindle is to support it with a steady rest (P/N 1074) while the end is being drilled. If this isn't possible, find the center with a centering square, prick punch a mark and center drill by hand. (See Figure 43, page 26 for a steady rest in use.)

HEADSTOCK DRILLING

The drill chuck comes fitted with a #0 Morse arbor that fits in the tailstock spindle. To use it in the headstock, you will need to first change to the #1 Morse arbor that is included with your chuck. To change arbors, put the drill chuck key in its hole to give you better purchase to grip the chuck while using a wrench to remove the #0 arbor. Replace it with the larger #1 arbor. Put the drill chuck in the headstock. Then put the drawbolt with its washer through the spindle hole from the other end of the headstock and tighten the drawbolt. **DO NOT OVERTIGHTEN!** (See Figure 30, next page.)

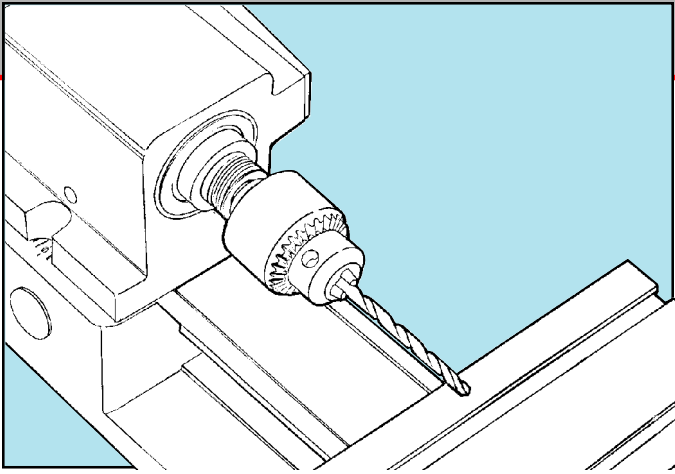

FIGURE 30—Headstock drilling. The drill turns in the headstock spindle while the work is held stationary.

REAMING

Twist drills will generally not drill perfectly accurate sizes, and very small boring tools are not satisfactory in deep holes because of their flexibility. Therefore, reaming is used for holes requiring accuracy within .0005" (.013 mm). Reamers are available in any standard size, but they are rather expensive and are generally not purchased to do one-of-a-kind type work. Use them only when a boring tool cannot be used because of the depth or size of the hole. Because of their length, they cannot always be used on a small lathe.

Reamers are used only to “clean up” a hole. To make an accurate hole, the work is drilled approximately .010" (.25 mm) smaller than the reamer size. The work should be slowly rotated and the reamer slowly fed into the hole while applying plenty of cutting oil. The reamer should be frequently removed and cleared of chips. Never rotate a reamer backwards in the work as this can dull the cutting edges.

FACEPLATE TURNING

The faceplate has three slots that allow work to be bolted to its surface. Flat work can be screwed directly to the faceplate. Extra holes can be drilled to suit odd shaped work unsuitable for a chuck. If the work is mounted off-center, be sure to counterbalance the faceplate and use very low RPM. Don't hesitate to drill holes in or modify the faceplate as needed to do a particular job. That's what they are for. They are inexpensive and you can have several on hand modified for special jobs.

TAPER TURNING

On some lathes, a taper is cut by offsetting the tailstock. On the Sherline lathe, taper turning is done by removing the headstock key and turning the headstock to any angle away from dead center. To rotate the headstock, the alignment key must first be removed. Loosen the set screw in the front of the headstock, and lift the headstock and motor unit off the locating pin. Tap the alignment key out of its slot on the bottom of the headstock, and replace the headstock unit on the pin. While pressing down on the headstock, rotate it to the angle you desire by referring to the angle scale on the bed. The base is calibrated in 5° increments up to 45° on either side of center. When set to

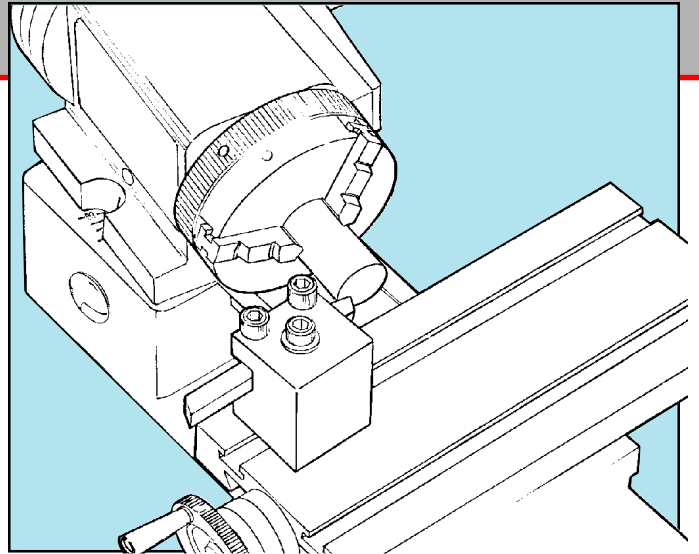

FIGURE 31—Turning a taper with the headstock slightly rotated.

the proper angle, retighten the set screw against the pin to lock the headstock into position. Tapers can also be cut without turning the headstock by using a compound slide (P/N 1270). See page 26 for a description.

Short work can be inserted in a 3- or 4-jaw chuck and turned as shown in Figure 26. If the headstock is angled towards the lathe front, the taper will be cut smaller at the right. Tapered holes can also be bored in work held in the 3- or 4- jaw chuck. To machine a taper on longer stock, center drill both ends of the bar, set the headstock angle and mount the part between centers. (See Figure 32.)

TOOL SHAPES AND GRINDING YOUR OWN CUTTING TOOLS

The shaping of cutting tools to suitable angles for the type of material and nature of work being performed can be very important to satisfactory work. When tools become dull, gently re-grind and preserve the original angles and shapes. Do not grind the top face of the tools, but confine sharpening to the end and/or sides except form tools which are ground on the top surface.

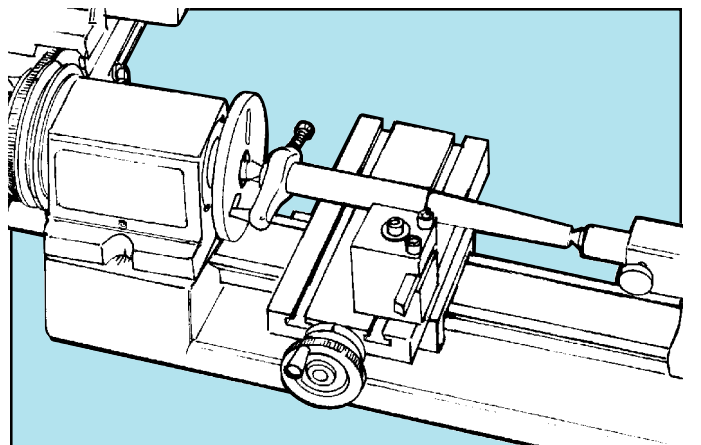

FIGURE 32—Long, shallow tapers can be cut in a continuous pass by pivoting the headstock to the proper offset while supporting the other end with the tailstock. The work is driven by using a drive dog in the faceplate. The dog acts like a “universal joint” as the drive pin slides in the faceplate slot.

Remember that heavy cuts and rapid feed will cause greater strain on the chuck and lathe. This may induce “spring” or binding of work and tools that can produce a poor finish.

NOTE: Because of the importance of a sharp and properly ground tool to the cutting process, Sherline has prepared a special instruction sheet on *Grinding Your Own Lathe Tools*. There are a few tips that can make the process a simple one. The instructions are included with each lathe and with cutting tool sets when you order them from us, or you may call us and request a copy. (Cost is \$5.00 postage paid.) They are also available from our Worldwide Web site at no cost. Unfortunately, space does not permit us to reprint them as part of this booklet.

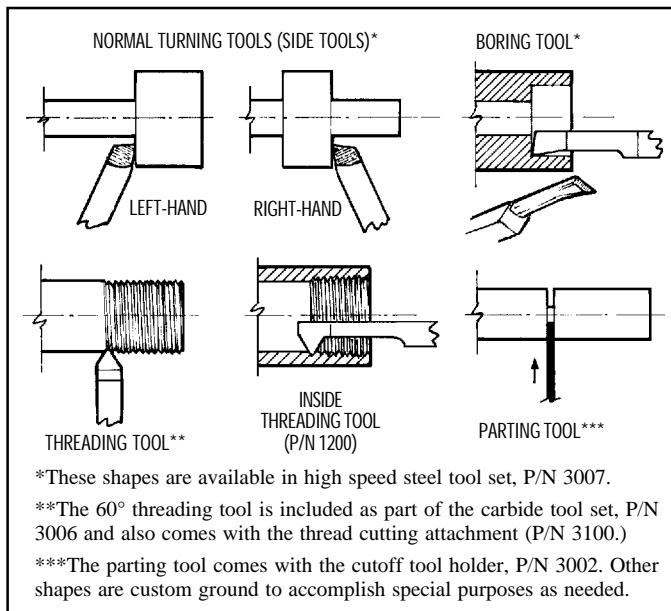

FIGURE 33—Cutting tool shapes

Cutting tools are ground to various shapes according to their usage. Tools are usually ground to shape as needed by the operator. Some standard tools are described below:

Normal Turning Tool—or RIGHT-hand tool feeds from right to left, is used to reduce work to the desired diameter and is the most frequently used of all tools.

Side Tools—These are used to face off the ends of shoulders and may also be used as normal turning tools. Note that a tool that is fed from left to right and has its cutting edge on the right is called a LEFT-hand side tool because the chip comes off to the left. Cutting tools are named based on which direction the chip comes off, not which side has the cutting face.

Parting Tool—The conventional parting tool or cutoff tool is shaped like a dovetail when viewed from above and is used to cut off work pieces by feeding the end of the tool across the lathe bed and through the work piece. The Sherline parting tool instead uses a thin .040" (1 mm) blade that has a slightly thicker ridge at the top to accomplish the same job of providing clearance for the tool while cutting. Parting tools thicker than .040" (1 mm) will be too thick for use on your Sherline lathe.

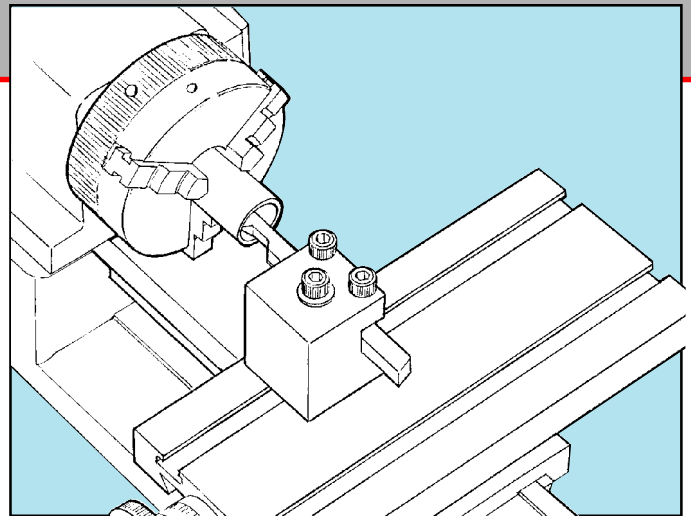

FIGURE 34—A lathe boring tool in use

Boring Tool—A boring tool is used in the tool post on a lathe or in an offsettable boring head on a mill to enlarge holes in a work piece. (See Figures 35 [lathe] and 52 [mill].)

Form Tool—A custom contour can be ground into a tool to produce a special shape like a radius in a part. The width of the cutting edge must be less than 2-1/2 times the smallest diameter. Cutting speed must be slow to prevent chatter.

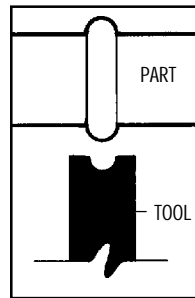

FIGURE 35—Form tool and part

The clearances ground behind the cutting edges indicate the type of material for which the tool may be used and the direction in which it is fed along the work. When grinding tool bits, correct clearances are essential or “rubbing” can occur.

The shape shown here would be difficult to grind on a home bench grinder; however, the same form could be achieved by grinding two separate tools with half the needed arc on the outside corner of each tool—a “left” and a “right.” By using a number of simple shaped tools in sequence, complicated forms can be generated.

Turning Tools (left and right hand)—Reference to Figure 36 will illustrate the lateral positioning of this tool. Note the clearance behind the point between the end of the tool and the work. Insufficient clearance will cause the tool to “rub,” and excessive clearance will produce a ridged or wavy

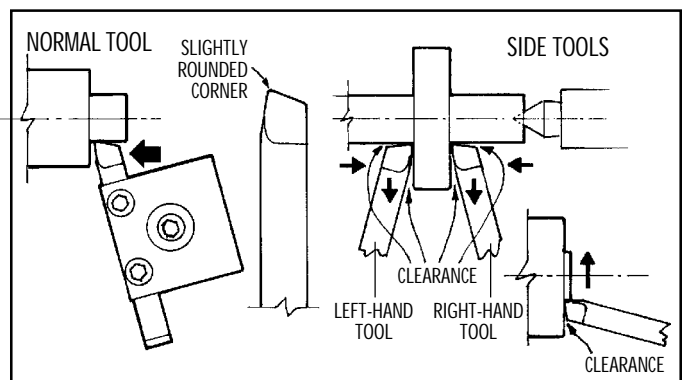

FIGURE 36—Arrows show direction of tool feed in all diagrams.

finish due to the small length of tool edge in contact with the work. This ridging becomes more pronounced with rapid feed. To provide a smooth finish, the sharp cutting point may be slightly rounded with an oilstone, taking care to preserve the side clearance underneath this corner.

This type of tool should not be advanced directly endwise into the work. The depth of cut is set while the tool is clear of the end of the work. The starting procedure is to advance the tool until the point just touches the work. Note the reading on the crossslide handwheel, withdraw the tool slightly and move along until clear of the end of the work. Now advance the crossslide to the above reading, add desired depth of cut and then feed the tool along the work piece the desired distance. Withdraw the tool clear of the work, having noted the reading on the crossslide handwheel. Mentally note the reading on the leadscrew handwheel, return the tool to starting position and advance to the previous reading **plus** the desired cut.

NOTE: Sherline offers optional adjustable “zero” handwheels that allow you to reset the handwheel to zero at any time...a handy feature normally found only on larger, more expensive machine tools. New tools may be ordered with them already installed, and existing tools can be retrofitted with them on any axis.

The second feed is now commenced, stopping at the same reading on the leadscrew handwheel as before. This procedure enables turning to accurate length.

Repeat the procedure until the work has been reduced to within about .010" (0.25 mm) of desired diameter, noting that each .015" (0.4 mm) increase in depth of cut will reduce the work diameter by twice this amount; that is, .030" (0.8 mm). For the finishing pass, advance the tool by the required amount and feed along the work just far enough to gage the finished diameter. Adjust depth of cut if necessary and complete the final pass using a SLOW feed to obtain a smooth finish and exact size.

USING THE CUTOFF OR PARTING TOOL

(See Figure 37.) After completing a part in the lathe, it is frequently necessary to separate the part from the excess material used for chucking. This operation is best accomplished with the use of a cutoff tool or “parting tool” as it is sometimes called. The Sherline cutoff tool and holder utilizes a very slender, high-speed tool steel cutting blade mounted in a special tool holder. The thinness of the blade (.040") enables it to feed into the part quite easily and at the same time minimizes the amount of waste material. A word of caution: **Never use a parting tool on a part mounted between centers.** The part may bind on the cutter, resulting in a scrapped part or a broken cutting tool.

Always try to lay work out so the cutoff tool is used as close to the spindle as possible. Set blade height by sliding the blade back and forth in the slightly angled slot in the tool holder. It should be set so the tip is aligned with the centerline of the part being cut. An unusual diameter may require a shim under the front or rear of the holder to

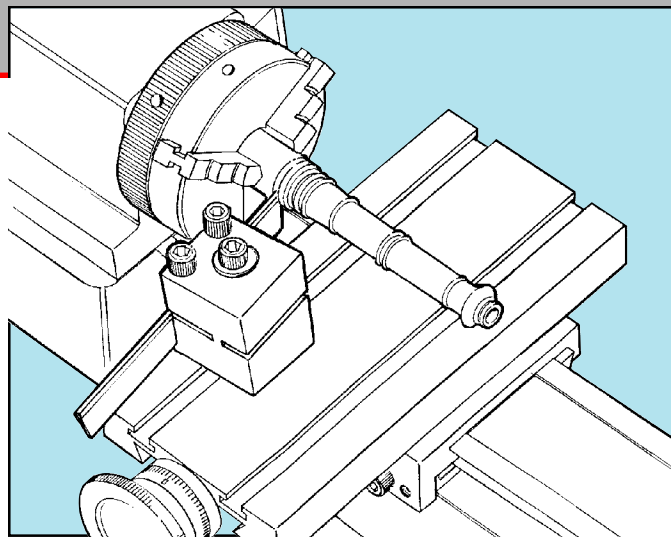

FIGURE 37—A parting tool used to separate a part from its bar stock.

accomplish this. The tool can also be mounted on the back side of the table by using the rear mounting block, P/N 3016.

IMPORTANT!

Always use cutting oil when using the cutoff tool. The cut will be made much smoother, easier and cooler.

The turning speed for parting should be about one-half the normal turning speed, and feed rate should be a little heavy so the chip will not break up in the slot. If speed and feed are correct, there will not be any chatter, and the chip will come out as if it were being unrolled. Cutting oil plays a major roll in this occurring properly.

If the tool chatters, first check to see if the work is being held properly. Then decrease speed (RPM) or increase feed rate or both. Once the blade has chattered, it leaves a serrated finish that causes more chatter. Sometimes a serrated finish can be eliminated by stopping the spindle, adding a liberal amount of cutting oil, bringing the blade up so there is a slight pressure on it without the spindle turning, and then turning the spindle by hand or as slowly as possible with the speed control.

Very small work may be completely cut off when held in a chuck and allowed to fall onto the crossslide. It is too small and light to cause any damage. Hollow articles, such as rings, may be caught on a piece of wire whose end is held in a suitable position.

SIDE TOOLS

While these may be, and often are, used as general purpose turning tools, their specific use is for facing the sides of collars and shoulders; that is, finishing these to correct dimension and with a smooth, flat surface. They are also for facing work held on a faceplate or in a chuck. The facing of work in this manner is very useful for the production of truly flat surfaces and for producing articles to an exact thickness. The uses of side tools are illustrated in Figures 33 and 36. The sharp corner at the cutting point should not be slightly rounded, as may be done with the normal turning tool, as knife tools may be required to produce sharp corners.

BORING TOOLS

The use of this tool requires the existence of a drilled or cored hole, or it may be used to enlarge the bore of a tube. The work must be mounted in a chuck or on a faceplate and the boring tool set as shown in Figure 34. Note the clearance behind the cutting point as shown in Figure 38 below.

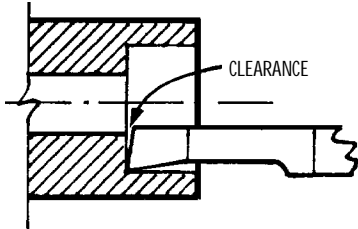

FIGURE 38—Boring tool clearance

A slow rate of feed should be used, as the turnings are not able to escape freely from the hole and can jam the tool. Frequent withdrawal of the tool to

allow turnings to escape may be necessary. Care should be taken not to feed the tool beyond the depth required or to feed so deeply as to damage the chuck or faceplate.

Where a hole must be bored right through the work, it should be shimmed out from the faceplate to provide clearance for the tool to feed through. The leadscrew handwheel graduations can be used to indicate the correct depth at which to stop the feed. Notice that, with boring, the depth of cut is increased by moving the tool and crossslide towards the operator and not away as with normal turning.

The boring of holes often necessitates greater than normal overhang of the tool from the tool post, so the depth of cut and rate of feed should be reduced from normal.

INSERTED TIP CARBIDE CUTTING TOOLS

Sherline brings the home shop machinist into the space age with cutting tools that add a new dimension to small lathes. When working with tough metals, high-speed steel tools need constant sharpening and have a relatively short life. Brazed carbide tools cut great but chip easily. Inserted carbide cutting tools are the answer and have replaced those other tools in the modern machine shop. Carbide inserts have the ability to consistently give good finishes and long tool life at a much higher cutting speed. This is especially important with small lathes, because they do not have excessive power at low RPM. With inserted carbide tools you can cut stainless steel at the same RPM you were formerly using to cut aluminum with high-speed steel tools without any sacrifice in quality in surface finish.

These tools are more expensive than high-speed steel; however, they are worth every penny if you have problems grinding your own steel tools or are cutting exotic materials like stainless steel. Sherline offers a tool post (P/N 7600) that holds the larger 3/8" square tool shanks used to hold carbide or diamond inserted tips. It also has a 3/8" round hole for boring tools.

A good starting point for an inserted tip tool is the P/N 2256 right-hand holder with a 35° offset. This holder uses the P/N 7605 carbide insert, which is a 55° insert good for turning, facing and profiling. A left-hand tool is also available as P/N 2257, or a set of both left- and right-hand tools is

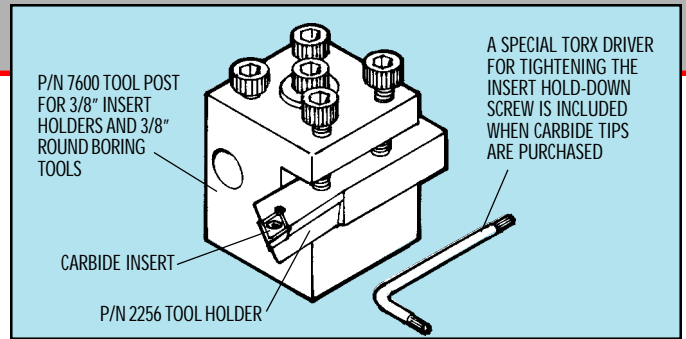

FIGURE 39—Carbide insert tool and tool post. The tool post holds both 3/8" square and round tools.

P/N 2258. Tools are also available to hold 80° inserts, which are slightly less versatile but offer longer tool life because of their stronger, more square shape. These tools should not be used to cut hardened steels or piano wire. Materials such as those should be ground to shape, not cut. Abrasive materials such as glass-reinforced plastics can be easily cut with these tools.

Another tool available to Sherline machinists that holds carbide inserts is the 3/8" IC 55° negative rake insert tool holder (P/N 7610). The indexable carbide insert sits on the tool holder at a 5° negative angle. This gives the sides of the cutter clearance even though the insert has square sides. By having square sides, both top and bottom of the insert can be used as cutting edges, giving a total of four cutting edges on each insert. Because of its design, it cuts like a positive rake cutter, which requires less rigidity than a negative rake cutter. It gives you the best of both worlds—the four cutting edges of a negative rake tool along with the lower stress loading of a positive rake cutter, which is appropriate for a lathe of this type.

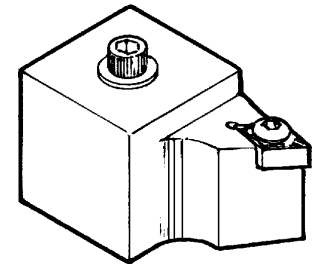

FIGURE 40—Negative rake insert tool holder (P/N 7610)

When searching for a mirrorlike finish on copper or aluminum, a four-sided diamond insert (P/N 7609) and a tool holder (P/N 7619) are also available. Though expensive, the four cutting edges of the diamond insert mean you are really getting four tools in one, making it a better deal than it may first appear.

NOTE: Never attempt to cut steel with a diamond cutter.

While inserted tip carbide and diamond cutting tools will improve the performance of the Sherline lathe, they will not correct poor machining technique. Rigid setups are a must for tools such as these.

TURNING SPEEDS

The following chart in Figure 41 provides a guide to speeds at which work of differing materials should be rotated. Note that the turning speed is inversely proportional to the diameter of the work; that is, the larger the diameter, the slower the turning speed. Material often differs in hardness, so these figures may have to be adjusted. The harder the material, the slower the turning speed should be.

GUIDE TO APPROXIMATE TURNING SPEEDS

Material	Cut Speed			
	1/4" (6mm) S.F.M.	1/2" (13mm) Diameter	1" (25mm) Diameter	1 1/2" (38mm) Diameter
Stainless, 303	67	1000 RPM	500 RPM	250 RPM
Stainless, 304	50	800	400	200
Stainless, 316	47	700	350	175
Steel, 12L14	174	2600	1300	650
Steel, 1018	87	1300	650	300
Steel, 4130	82	1250	650	300
Gray Cast Iron	57	900	450	220
Aluminum, 7075	400	2800	2800	1400
Aluminum, 6061	375	2800	2800	1400
Aluminum, 2024	268	2800	2000	1000
Brass	400	2800	2800	1400

FIGURE 41—Turning speeds for high-speed steel cutting tools

Keep in mind that, apart from possible production of excessive heat and the fact that excessive speed may damage the cutting edge or cause it to “rub” instead of cutting, turning speeds are not too critical. Slower than normal speeds cause no harm, except by increasing the time involved. Aluminum, however, usually gives a better finish turned at high speed and with the use of lubrication (coolant).

ACCESSORIES FOR THE LATHE

Your lathe can be made more versatile with the addition of suitable attachments and accessories. These include various chucks and collets, a thread-cutting attachment, vertical milling column, knurling tool, a live center and many others. Remember that accessories and attachments must be cared for in the same way as the lathe. Always make sure that threads are free from metal chips and dirt. Chucks should be lightly oiled frequently so that they continue to function smoothly and accurately. Gears in the thread-cutting attachment should be lightly greased when in operation. Some attachments have moving slides, and these should be lubricated in the same way as the slides in your lathe. Each accessory comes with complete instructions for its use when it is purchased.

Following are shown some of the more popular lathe accessories along with a brief description of their purpose. When parts are available in both inch and metric configurations, the inch part number is given first followed by the metric part number in parenthesis.

3-JAW, 4-JAW AND DRILL CHUCKS

Chucks are used to hold work in the lathe. They can also be used to function like a vise to hold a part for milling. Drill chucks can be used in the lathe headstock or tailstock or in the mill for drilling. Here are some of the chucks available for your Sherline tools:

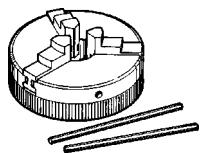

P/N 1041 2.5" 3-jaw chuck—Three jaws scroll in unison to grip round or hex stock from 3/32" (2 mm) up to 1-3/16" (30 mm) in diameter. Jaws are reversible for holding larger stock up to 2-1/4" (56 mm) in diameter. The chuck has a .687" (17 mm) through hole and 3/4-16 spindle thread.

P/N 1040 3.1" 3-jaw chuck—This is a larger version of the P/N 1041 chuck. It holds parts up to 1-1/2" (38 mm) in diameter in normal position and up to 2-3/4" (70 mm) with the jaws reversed. Same through hole and spindle thread.

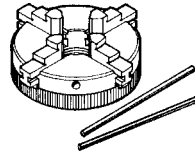

P/N 1075 2.5" 4-jaw self-centering chuck—This chuck holds round or square stock from 3/32" (2 mm) up to 1-3/16" (30 mm). With the jaws reversed, it will grip stock up to 2-1/4" (56 mm). The jaws scroll in unison as on the 3-jaw chuck. (NOTE: stock held in this chuck must be perfectly round or square to be gripped by all four jaws.)

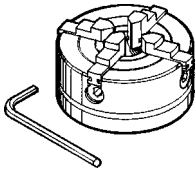

P/N 1044 2.5" 4-jaw (independent) chuck—Each jaw is adjusted independently, allowing precise adjustment for perfect centering or for holding odd-shaped parts. Four-jaw chucks take a little more time to use, but offer much greater accuracy and versatility than a 3-jaw chuck. Holding range is the same as the P/N 1041 3-jaw chuck.

P/N 1030 3.1" 4-jaw (independent) chuck—A larger version of the chuck above for holding larger work. Holding range is the same as the P/N 1040 3-jaw chuck.

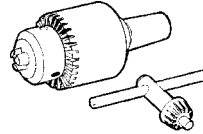

P/N 1072 1/4" Jacobs drill chuck—A conventional Jacobs drill chuck fitted with a #0 Morse arbor so it can be used in the tailstock for center drilling parts. It also comes with a #1 Morse arbor and drawbolt so it can be used in the headstock on the lathe or mill. Adjustment key included. Holds drills from 1/4" down to about 1/64", although for drills smaller than 1/32" we recommend our 5/32" chucks (See P/N 1010/1015 below).

P/N 1069 3/8" drill chuck—A larger size Jacobs chuck with arbors for use in either the headstock or tailstock. It is recommended for the long bed lathe, where the greater center-to-center distance allows the use of larger drills and reamers. Adjustment key, arbors and drawbolt included.

P/N 1010/1015 5/32" drill chuck—A small Jacobs chuck that holds drills from 5/32" down to #80. The arbors are pressed into a #0 Jacobs taper, so separate chucks are needed for the headstock and tailstock. P/N 1010 has a #1 Morse taper for the headstock, P/N 1015 has a #0 Morse taper for the tailstock. The chuck's small size can also make it the proper choice for some setups where space is limited. Adjustment key included. Drawbolt included with P/N 1010.

THREAD-CUTTING ATTACHMENT, P/N 3100

Common threads are most easily cut using taps and dies, but it would be impossibly expensive to own a tap and die for every conceivable thread size. Cutting threads on a lathe is the traditional alternative. A lathe cuts threads by gearing the leadscrew directly to the spindle. This is called

Not yet on line? Many public libraries offer Internet access. Call your local branch for information.

“single pointing” a thread. When the spindle turns, the saddle moves. If they were geared one-to-one, the cutting tool would cut a pitch that would be the same as the leadscrew. On Sherline’s inch machines, this would be 20 threads per inch. If the leadscrew turns 180° while the spindle turns 360° (by using a 20-tooth to a 40-tooth gear reduction) we would cut 40 TPI. Note that threads can be applied to any diameter stock.

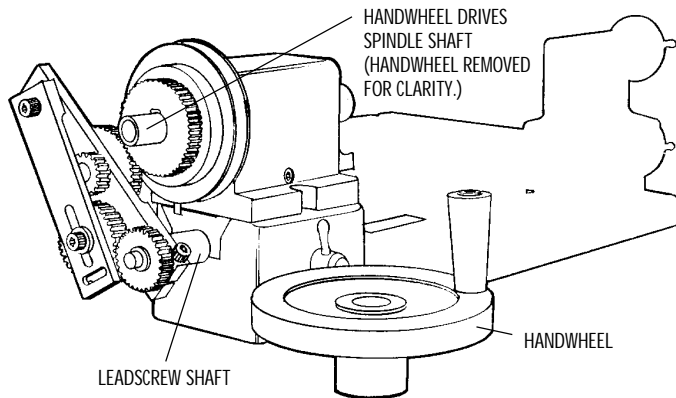

FIGURE 42—Sherline’s thread-cutting attachment. (Handwheel is removed for clarity.)

Sherline’s thread-cutting attachment provides all the necessary gears and support arms to cut any thread from 80 TPI down to 5 TPI. Both left-hand or right-hand threads can be cut. With the use of a 127-tooth change gear, metric threads from .25 to 2.0 pitch can be cut on an inch machine and inch threads can be cut on a metric machine. A large handwheel replaces the motor and speed control to drive the spindle, so that you have total control over the thread-cutting process. Though this might sound like a step backwards, it actually is a very practical system for cutting small threads, allowing you to cut right up to a shoulder if need be. A carbide 60° thread-cutting tool is included, and an inside threading tool (P/N 1200) is also available as an option. Complete instructions include a chart of the gear combinations to achieve the threads mentioned above.

With this attachment and your lathe, you will never be stuck without a way to come up with the right thread. Even if a tap or die is available, you can set up and cut a thread faster than you could get to the store and back to buy it and save yourself some money as well!

STEADY REST, P/N 1074

The steady rest supports longer work with three adjustable brass pads. It keeps long parts from deflecting away from the tool or wobbling while turning and steadies the end of long parts for center drilling. Along with a live center, this is one of the first accessories most lathe owners add to their tool box.

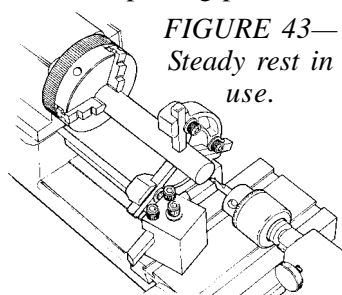

ADDITIONAL LATHE ACCESSORIES

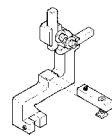

1090 Follower rest—Moves with lathe saddle. Two brass pads provide support right behind the cutting tool to keep long, thin stock from deflecting during a cut.

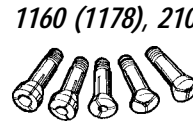

1160 (1178), 2100, -01, -02, 1162 (1179) WW Collet sets—Holding work in individually sized collets is a more accurate method than holding in a chuck. A number of sets of standard collets, collet pot chucks and deluxe collet sets are available.

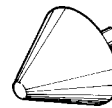

1182 Bullnose live center—For supporting the end of tubing or parts with a large end hole up to 1-5/8". Two preloaded ball bearings, #0 Morse tapered shaft.

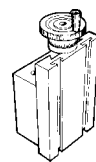

1185 (1184) Vertical milling table—Mounts to the lathe table to provide a vertical Z-axis movement of 2.25" (57 mm). Although the vertical milling column (P/N 3050/3053) is the preferred method, this is a traditional method of doing small milling jobs on the lathe. It is also useful for special setups on the vertical mill.

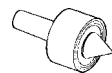

1191 Live center—Replaces tailstock dead center for holding work. Ball bearing reduces friction while turning between centers.

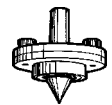

1201 Adjustable live center—Ball bearing live center with adjustable backing plate allows precise alignment of headstock and tailstock. Adjustable tailstock accessories like P/N 1201, 1202 and 1203 are for the craftsman seeking the ultimate in precision.



1202 Adjustable tailstock chuck holder—Allows perfect centering adjustment for tailstock chuck.

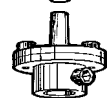

1203 Adjustable tailstock custom tool holder—Adaptable to hold any tool you wish on perfect center in the tailstock.

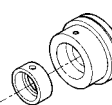

1206 Adjustable tailstock 1" die holder—Holds 1" dies for threading shafts. Includes a 13/16" bushing for holding smaller size dies.

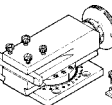

1270 Compound slide—Mounts to the “back” side of the lathe table. Allows cutting of angles that can’t be achieved by “swinging the headstock” or turning between centers. Laser engraved base has angle scale for reference.

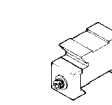

1290 Steady rest riser block—Raises steady rest to proper height for use with headstock and tailstock riser blocks.

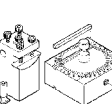

1291 Headstock riser block—Raises headstock 1.25" (31.7mm) for more clearance to turn larger stock (up to 6" in diameter). Also includes riser rocker tool post.

To view or print complete instructions for all Sherline accessories, see www.sherline.com/accessor.htm.

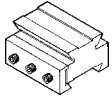

1292 Tailstock riser block—Raises tailstock 1.25" (31.7 mm) to align it with headstock when using the P/N 1291 riser block.

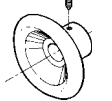

2049 Spindle handwheel—Steel handwheel mounts on the end of the spindle shaft and allows the operator to quickly and safely stop a rotating spindle with his hand. It also makes it easy to hand index the spindle when working on a part.

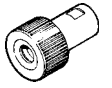

2085 (WW) and 2086 (8mm) collet adapters—Held in P/N 1203 adjustable tool holder above (not included), collet adapters allow you to use WW or 8.0 mm collets in the tailstock to hold small drills accurately on center.

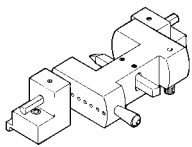

2200 Radius cutting attachment—Mounts to lathe table. The body pivots on centers to allow the tool to cut a concave or convex radius or ball end on the end of a part.

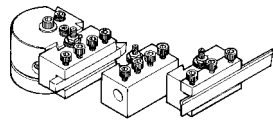

2250 Quick-change tool post—Steel tool post has a dovetail slide that accepts various holders to allow rapid tool changes. Holders include a 1/4" standard cutting tool holder, 3/8" boring tool holder and cutoff tool holder. An optional inserted tip carbide holder (not shown) is also available (P/N 2295).

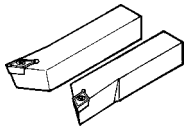

2258 35° RH and LH insert tool holders—3/8" square shaft tool holders accept 55° carbide inserts. Available individually as right-hand (P/N 2256) and left-hand (P/N 2257) holders or as a pair (P/N 2258). Carbide insert included with each.

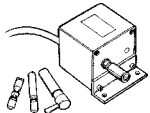

3001 Power feed—A constant speed, single-direction motor with on/off switch drives the leadscrew at .9" per minute. A lever below the headstock engages and disengages the drive. Saves a lot of hand cranking on long parts and provides smooth finishes.

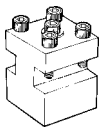

3003 Two-position tool post—Save time by mounting two 1/4" cutting tools at once so you can switch quickly from one to the other by rotating the tool post. (P/N 3008 looks similar but holds a 5/16" and a 3/8" tool.)

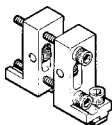

3004 Knurling tool—Mounts to the lathe crossslide. Knurls are produced by embossing, not by cutting, and this creates high tool loads. Using two knurls opposing each other equalizes these loads, allowing successful knurling on a small machine.

A number of patterns can be achieved by changing the knurls. A 25 thread per inch, medium diamond pattern set comes with the tool. A number of additional straight and spiral knurls can be ordered.



3015 Toggle switch dust cover—Protects on/off switch on speed control from fine dust generated by cutting brass or wood.

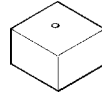

3016 Cutoff tool rear mounting block—Allows the parting tool holder (P/N 3002) to be used on the back side of the table. The cutoff tool blade is turned upside down in the holder and this 13/16" high spacer block keeps the tool's cutting point at the lathe's centerline. A cutoff tool can remain mounted out of the way on back side of table and be brought into use quickly for cutoff operations.



3035 Spur Driver—A simple way to drive wood from the headstock in place of a 3-jaw chuck.

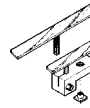

3038, 3047 Wood Tool Rests—Allows wood turning on the lathe using hand-held wood cutting tools. Includes base with 3" and 5" long rests.

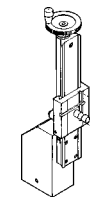

3050 (3053) Vertical Milling Column—Mounts in seconds to provide three axes of movement to turn your lathe into a milling machine. Your lathe's headstock and motor/speed control mount to a saddle on the column. Z-axis column provides the same 6.25" (159 mm) vertical travel available on the Sherline milling machine.

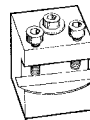

3057 Rocker Tool Post—Allows exact control of tool tip height in relation to part centerline. Tips of older, resharpened cutting tools can be adjusted up to proper cutting height without having to use shims.

4150 (15") and 4151 (24") Vinyl Dust Covers—Clear 6-mil fitted cover protects your lathe from grit and dust when not in use. Adds a professional touch to your miniature machine shop. Includes a red Sherline logo.

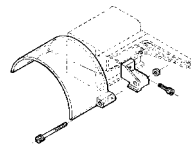

4360 Chip Guard—A clear, tough polycarbonate shield mounts to the headstock to contain chips and cutting fluids near the chuck. Swings out of the way for changing setups.

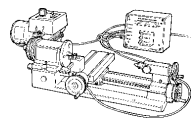

8200/8260 Digital Readout—Add a two-axis digital readout to any new or existing lathe. Also includes continuous RPM readout. Reads to .0005". Reset display to zero with the push of a button. Special

handwheels replace standard handwheels. Available with third axis readout for use with a vertical milling column.

CNC-Ready Lathes—Existing Sherline lathes can be converted to CNC use, or new lathes can be ordered CNC ready. Included are stepper motor mounts with preloaded bearings and couplers. (Does not include stepper motor or CNC hardware or software.)



8800 Programmable Power Feed—Drive your lathe leadscrew and/or crossslide with a stepper motor. Two units can be "daisy-chained" for coordinated sequential movements. Retrofit kits available with or without stepper motor

mount. Includes stepper motor, cables, control box and power supply.

3-JAW CHUCK OPERATION AND MAINTENANCE

The 3-jaw self-centering chuck is the most popular of all the accessories available for the Sherline lathe. It is available in both 2-1/2" diameter (P/N 1041) and 3-1/8" diameter (P/N 1040). These chucks will grip round or hexagonal work quickly, since the jaws move simultaneously to automatically center the work being held. The jaws on the chuck are designed so that the same chuck can be used for both internal and external gripping. Jaws are reversible for holding larger diameter work. Due to the nature of the design of a 3-jaw chuck, it cannot be expected to run perfectly true. Even 3-jaw chucks costing five times more than the one made for this lathe will have .002" to .003" runout. If perfect accuracy is desired in a particular operation, the use of a 4-jaw chuck is recommended. Each jaw is adjusted independently so parts can be centered with total precision. Both a 2-1/2" and 3-1/8" 4-jaw chuck are available for the Sherline lathe as P/N 1044 and P/N 1030 respectively.

NOTE: DO NOT TURN THE LATHE SPINDLE ON WITHOUT HAVING THE CHUCK TIGHTENED. The acceleration of the spindle can cause the scroll to open the chuck jaws if not tightened!

The 2-1/2" 3-jaw chuck (P/N 1041) is designed to take up to 1-3/16" (30 mm) diameter stock with the jaws in the normal position. The 3-1/8" 3-jaw chuck (P/N 1040) is designed to take up to 1-1/2" (38 mm) diameter stock. For larger diameter work, reverse the jaws (See Fig. 46). To prevent permanent damage, finished, turned or drawn stock should only be held with this chuck. For rough castings, etc., use a 4-jaw chuck.

DO NOT OVERTIGHTEN THE CHUCK. Use only moderate pressure with the spindle bars (P/N 40580) supplied.

To reverse the chuck jaws, rotate the knurled scroll until the jaws can be removed from the chuck body. After the

jaws are removed, they can be easily identified by the location of the teeth in relation to the end of the jaws (See Figures 45 and 46). To maintain chuck accuracy, the 2nd jaw must always be inserted in the same slot even when the jaws are reversed. This slot is identified by the laser engraved letter "B" next to the slot. Always insert the jaws in the order and location shown on the drawings. Turn the scroll counterclockwise when viewed from the face of the chuck until the outside start of the scroll thread is just ready to pass the slot for the first jaw. Slide the first jaw as far as possible into the slot. Turn the scroll until the first jaw is engaged.

Due to the close tolerances between the slot and jaw, the most difficult part in replacing the jaws is engaging the scroll thread and first jaw tooth without binding. Therefore, never use force when replacing the jaws, and, if binding occurs, back up the scroll slightly and wiggle the jaw until it is free to move in the slot. Advance the scroll and repeat for the second and third jaws. The scroll thread must engage the first tooth in the first, second and third jaws in order.

REMOVING A CHUCK FROM THE SPINDLE

Use one tommy bar in the hole in the spindle and another tommy bar in a hole in the chuck body to achieve enough leverage to unscrew the chuck (counterclockwise) from the spindle thread. If the chuck becomes stuck on the spindle thread, put a tommy bar in the hole in the chuck body. Place a block of wood against the tommy bar where it enters the chuck. With a small mallet, give the block of wood a sharp tap, turning the chuck in a counterclockwise direction. It should not be necessary to hold the spindle, as its inertia should be sufficient. (Don't hit the tommy bar anywhere other than right where it enters the chuck or you could bend it.) This small but sharp force at the outer edge of the chuck should break the thread loose and the chuck can then be unscrewed using the tommy bars.

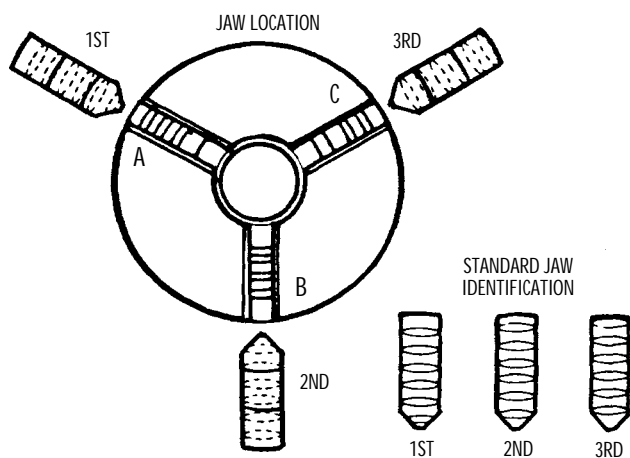

FIGURE 45—Jaw locations and identification

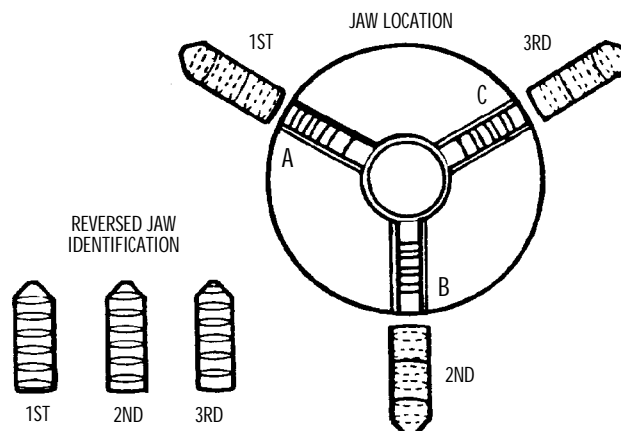

FIGURE 46—Reversing the chuck jaws.
NOTE: Always start with position "A."

VERTICAL MILLING MACHINE OPERATION

CAUTION!

READ ALL OPERATING INSTRUCTIONS CAREFULLY BEFORE ATTEMPTING ANY MACHINING OPERATIONS.

NOTE: See pages 4 through 18 for setup, lubrication and general machining instructions. **Read *Safety Rules for Power Tools* on page 3 before operating machine.**

GENERAL DESCRIPTION

At first glance, a vertical mill looks similar to a drill press, but there are some important design differences; for example, the mill has a spindle that can take side loads as well as end loads and an accurate method of moving work in relation to the spindle on all three axes. It is wise to memorize these “X,” “Y” and “Z” axes, because, since the advent of complex electronically controlled milling machines, these terms have become common “shop talk,” even outside engineering departments. Feed screws with calibrated handwheels control movements on these three axes. The handwheel calibrations are quite accurate and should be used whenever possible.

Angles can be machined by removing the headstock alignment key and rotating the milling head to the appropriate angle to the work or by holding the work at an angle to the spindle. (Note: Lighter than normal cuts should be taken when the alignment key is not in place.) The latter method must be used for drilling on 5000/5400-series mills to keep the drill movement parallel with the machine slide. Angle drilling can also be accomplished without removing the alignment key by using the optional rotary column attachment (P/N 3500). (The Model 2000 mill is also capable of angle drilling due to its multi-axis design.) All machine

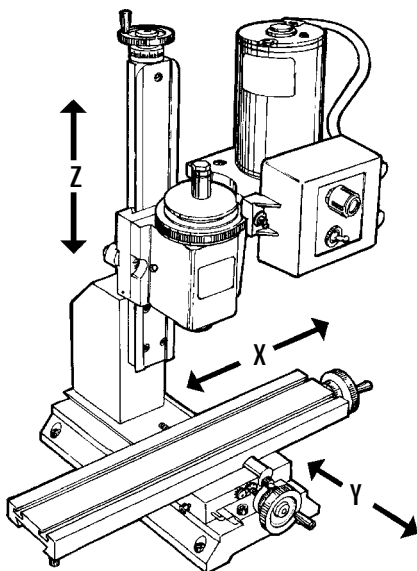

FIGURE 47—The axes of movement for milling on a standard 3-axis vertical milling machine.

slides have an adjustable gib to compensate for any “play” that may develop. (See “adjusting gibs” on page 11.)

It is assumed that anyone purchasing a vertical milling machine has had some experience working with metal cutting tools; therefore, these instructions are somewhat limited for a beginner. There is enough information, however, to enable a good craftsman to get started. Using a vertical mill correctly takes more skill and experience than is required for lathe operation because of the additional axis (vertical) and the more varied type of work that can be performed.

The machine must be well maintained, for it is subject to higher stresses than a lathe. This particular mill is one of the smallest being manufactured and is an extremely useful tool. However, it would be unreasonable to clamp a 3-pound piece of stainless steel to the work table and expect to make a 1-pound part from it. The key point is to work within the capabilities of the machine, and those limitations can only be determined by the operator.

HELPFUL TIPS FOR MILLING

- This is a small, light-duty mill and should not be used to remove large amounts of stock that could be easily removed with a hacksaw. For efficiency, select a piece of stock as close to finished size as possible.
- Stresses on a mill are quite high when cutting most materials; therefore, gib and backlash adjustments must be properly maintained. (See “Adjustments” section beginning on page 10.)
- End mills must run true and be sharp. Holding end mills in a drill chuck is a poor practice. Use collets or an end mill holder instead. The 3/8" end mill holder (P/N 3079)

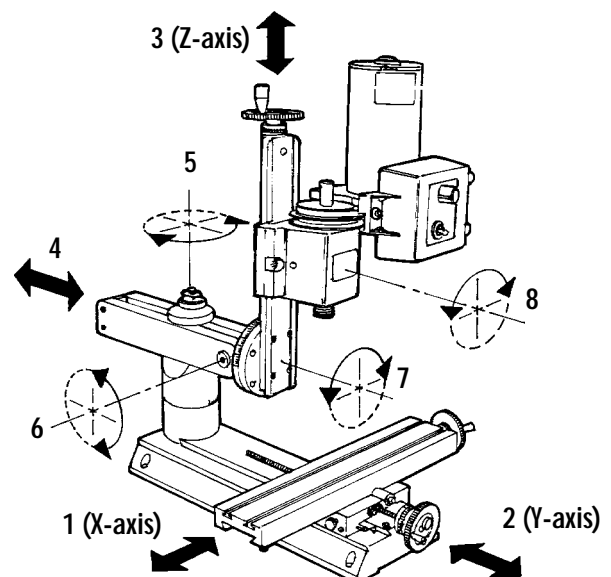

FIGURE 48—Eight directions of movement of the model 2000 series milling machines

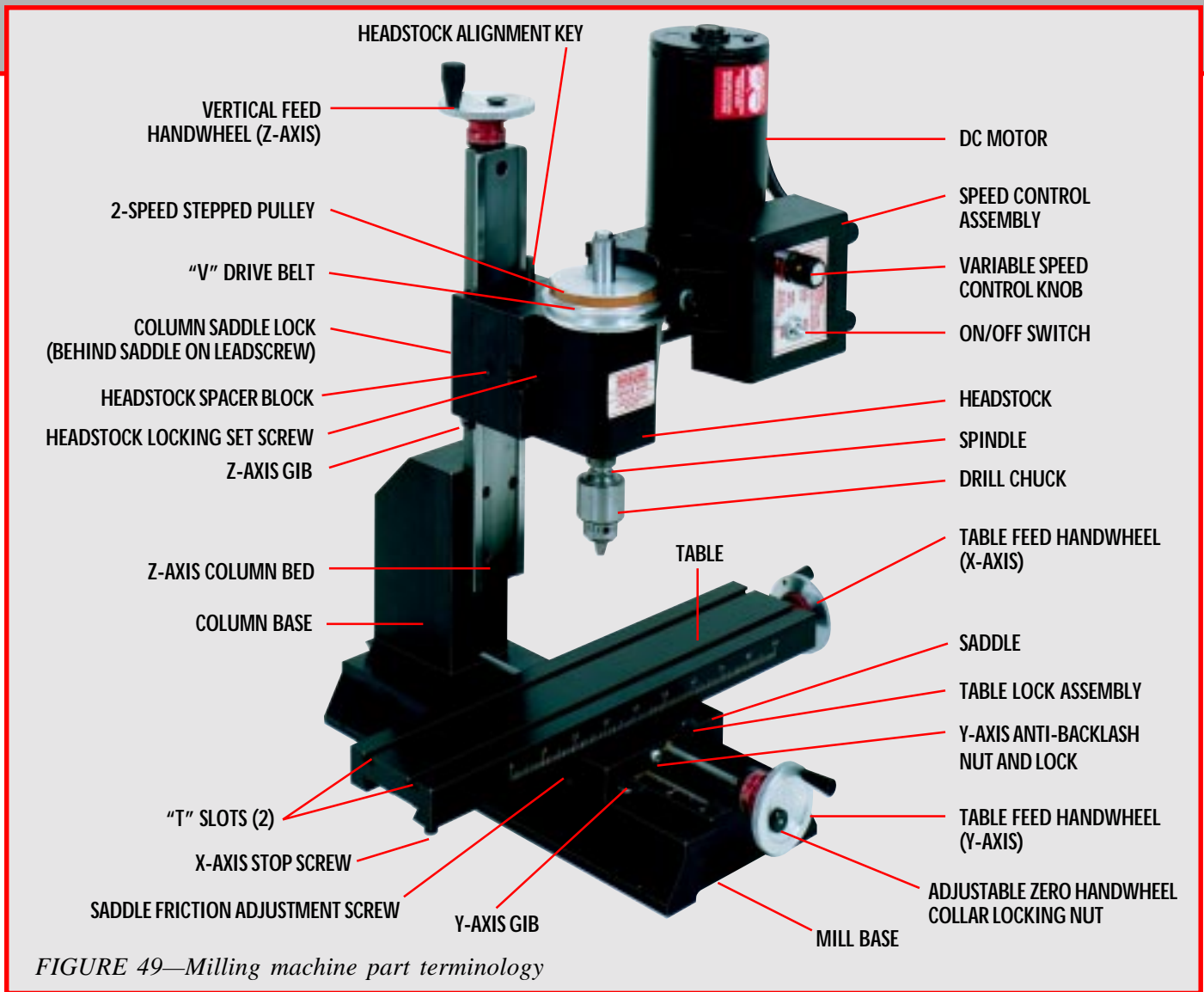

FIGURE 49—Milling machine part terminology

allows you to use a large range of readily available 3/8" end mills with your machine. (Several other size inch and metric end mill holders are also available.)

- Fly cutting is an excellent way of removing stock from flat surfaces.
- Normal machine alignment is adequate for most work, but if the work is exceptionally large or requires extreme accuracy, shims may be employed to improve machine alignment.
- For accurate setups you should have and know how to use a dial indicator.
- Often, more time will be spent making fixtures to hold work than doing the actual machining.
- To help save time on many simple setups, a good mill vise is a must. A drill press vise is not designed for the forces involved in milling.
- Plan ahead. Always try to have one point from which to measure. Do not machine this point off part way through the job. This would leave you with no way of measuring the next operation.
- Remember the basic machining rule that says: "If the tool chatters, reduce speed and increase feed."

- It takes a long time to accumulate the knowledge, tools and fixtures required for many different types of milling operations. Do not become discouraged by starting with a job that is too complex or by using materials that are extremely difficult to machine.

SECURING THE WORKPIECE

The first problem encountered will be holding the work and aligning it to the machine. It is important for reasons of safety and accuracy that the workpiece be solidly secured. This may be the most difficult task, since once the work is clamped in position, the method of doing the entire job has been established. Usually, a rectangular block can be easily held in a mill vise. Note that round stock may also be held in a "V" shaped vise slot. Mill vises are specially designed to pull the movable jaw downward as they tighten on it. (See Mill Vise P/N 3551 shown in figure 71 and in the *Sherline Tools and Accessories Catalog*.)

Certain objects can be secured with a 4-jaw lathe chuck, which is, in turn, clamped to the machine. Some irregular shapes, such as castings, may present greater difficulties. Often they may be clamped directly to the table. Very small or irregular shapes can be secured by epoxying them to a second, more easily held piece of material. They are broken

loose after machining. A mill tooling plate (P/N 3560) is a very useful fixture for holding parts. It has a number of holes predrilled for holding clamps, and additional holes can be drilled and tapped as needed. It also provides additional stiffness and protection for your mill table.

THINGS TO CONSIDER BEFORE YOU START CUTTING

The following steps should be considered before commencing any part:

- Is the material about to be machined best suited for the job, and is it machinable with available cutting tools and equipment? Work with aluminum, brass, plastic or cast iron whenever possible. Too often a hobbyist will pick up the first correctly-sized piece of material he finds at his local salvage dealer thinking that, if it is rusty, it's steel, and that all steels are pretty much the same. Not so! Anyone who has ever tried to machine an old automobile axle can attest to this. If the part must be steel, grade 12L14, commonly called "lead-loy," is about the best material for machining. It was developed for screw-machine use and is available in round stock only. However, it works so well that many times it may be advisable to machine rectangular parts from it. It can also be case hardened. Your local screw-machine shop will usually have scrap pieces available and may be a good source for obtaining it.
- Avoid exotic materials, such as stainless steel, unless absolutely necessary because of machining difficulty and poor milling cutter life. (If each new mechanical engineer were given a block of stainless steel to mill, drill and tap

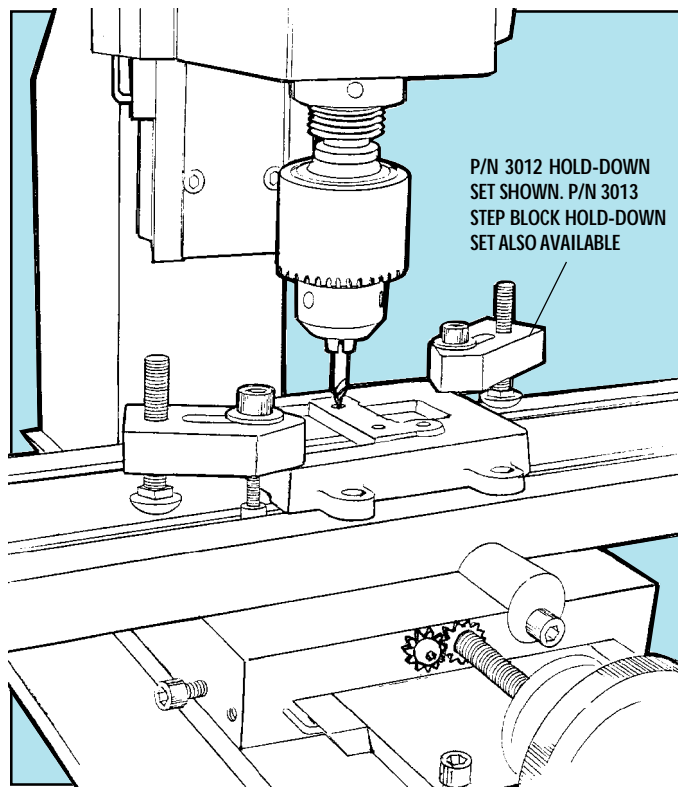

FIGURE 50—Center drilling a part clamped to the table with the hold-down set

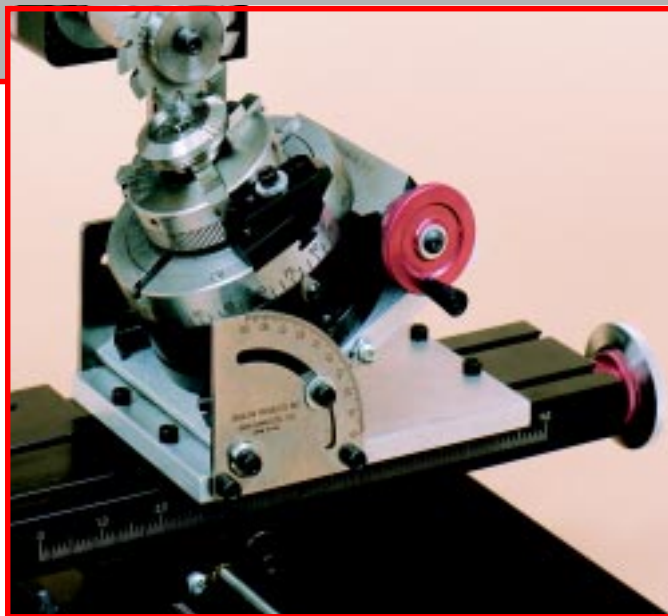

FIGURE 51—A complex setup shows a part held in a 3-jaw chuck, which is mounted to the rotary table, which is mounted to the tilting angle table, which is in turn mounted to the mill table. A mill arbor holds a gear-tooth cutter which is cutting teeth in a bevel gear. The horizontal milling conversion is used to mount the headstock in the horizontal position. With Sherline tools and accessories, the parts you machine are limited only by size, not by complexity.

upon his graduation, stainless steel sales would probably drop considerably!)

- Before beginning, carefully study the part to be machined. Select the best surface from which to work (usually the flattest).
- Decide if work should be "rough cut" to size. Some materials will warp while being machined. Close tolerance parts can be destroyed by attempting heavy machining at the end of the job rather than at the beginning.
- The method of holding the work is also determined by the type of machining to be performed. For instance, work that involves only small drilling jobs does not have to be held as securely as work to be milled.
- Lay the job out so that it can be machined with the minimum number of setups.
- Be sure to have all needed cutting tools available before beginning a job.
- Do not start off with a job so complex that the odds of success are limited. Making complex machined parts requires a great deal of intelligence, planning and skill. Skill is acquired only through experience.

In summary, you should become aware of the fact that milling is difficult, but not impossible. There are many more considerations than just moving the handwheels, and you should not start your first step until your last step has been determined.

PURCHASING MATERIALS IN SMALL QUANTITIES

Commercial metal suppliers are not set up to serve the home shop machinist. They usually have large minimum

CAUTION! Because the tool spins on a mill, hot chips can be thrown much farther than when using a lathe. Safety glasses and proper clothing are a must for all milling operations.

order quantities and high “cutting charge” fees that make it impractical to purchase small amounts from them. However, there are now a number of suppliers that cater to the hobby market. They have complete catalogs of the materials most commonly used by hobbyists, and you can order as much or as little as you need. The price per inch is somewhat higher than industrial rates, but the convenience and overall savings make it well worth it. There are several suppliers listed in Sherline’s web site. Your local scrap yard can also be a good source for raw materials at good prices. Bring your own hacksaw, and be aware that the some yards are better than others at identifying and organizing the materials. If you are not sure exactly what kind of metal you are getting, you could be letting yourself in for a lot of trouble when you start cutting. See www.sherline.com/online.htm for a list of sources for obtaining raw material in small quantities.

THREE TYPES OF WORK

There are three basic types of work that can be performed with a vertical milling machine: milling, drilling and boring. It would be extremely difficult to determine whether a vertical mill or a lathe would be the most valuable machine in a shop. Theoretically, most vertical mills are capable of reproducing themselves with standard milling accessories such as a rotary table and centers. This would be impossible on a lathe without exotic modifications and attachments. These instructions briefly describe standard vertical mill work. Many comprehensive books are available on this subject, and, although the machines they describe are much larger, the principles remain the same. A good starting point is a book we offer called *Tabletop Machining*. It is printed in full color and is available through Sherline as P/N 5301. Sherline tools are used throughout in all the setups and examples. Also available is a black and white book, *The Home Shop Machinist’s Handbook* (P/N 5300) by Doug Briney which features Sherline tools as well. (See more on books and videos for machinists on page 41.)

TYPES OF MILLING CUTTERS

Milling on a vertical mill is usually accomplished with end mills. These cutters are designed to cut with both their side and end. (See Figure 60, Page 35.) Drilling is accomplished by raising and lowering the entire milling head with the Z-axis feed screw. Center drills must be used before drilling to achieve any degree of accuracy. (See Figures 50 and 69.) Note that subsequent holes may be accurately “dialed in” from the first hole by using the calibrated handwheels. Each revolution of the wheel will yield .050” of travel or 1mm for the metric machines. There is no need to start with the handwheel at “zero,” although this can be easily accomplished with the optional resettable “zero” handwheels to make calculations easier.

Boring is a method of making accurate holes by rotating a tool with a single cutting edge, usually in an adjustable holder called a “boring head.” It is used to open up drilled holes or tubing to a desired diameter. (See Figure 52.)

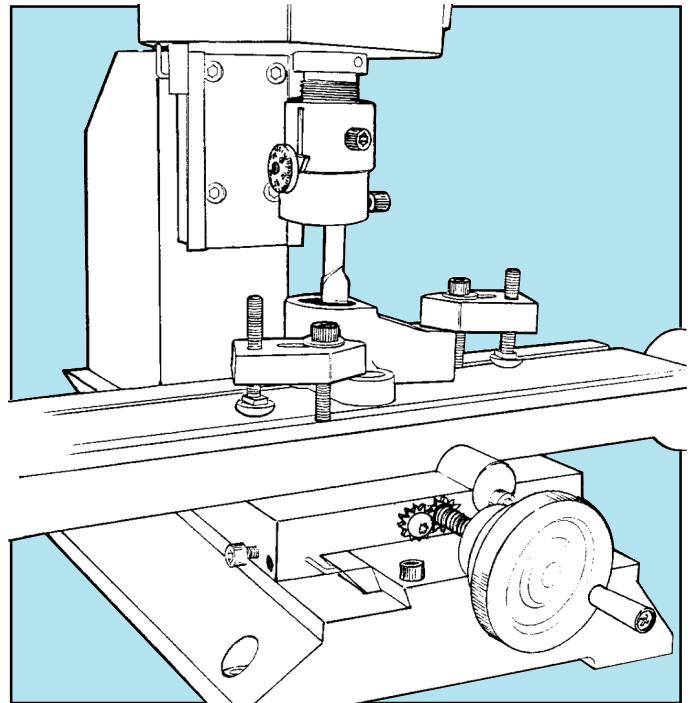

FIGURE 52— Boring the inside of a hole to exact size with a boring tool held in a boring head.

Another type of milling is performed with an adjustable fly cutter, which may be used for surfacing. For maximum safety and rigidity, the cutting bit should project from the holder no further than necessary. A 1-1/2” diameter circle of cut is quite efficient, and multiple passes over a surface should overlap about 1/3 of the circle size. For machining aluminum, use a speed of 2000 RPM and remove about .010” (0.25 mm) per pass. (See Figure 68 on page 37.)

STANDARD MILLING VERSES CLIMB MILLING

It is important to understand that the cutting action of a milling cutter varies depending upon the direction of feed. Study the relationship of cutting edges to the material being cut as shown in Figure 53. Note that in one case the tool will tend to climb onto the work, whereas in the other case the tool will tend to move away from the cut. The result is that climb milling should normally be avoided except for very light finishing cuts.

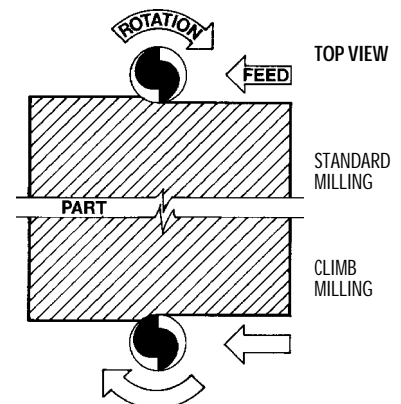

FIGURE 53— Standard vs. climb milling. For clarity, imagine the cutter is moving rather than the part.

CLIMB MILLING ADVANTAGES AND DRAWBACKS

Though you will almost always use conventional milling, climb milling can create a better finish in two ways. First, the lightest part of the cut is at the end of the cut. Second, the chips are tossed from the cutting area and do not affect the finish.

The major problem with machining in this direction is that the cutter may actually do just that—climb up on the part and break. Also, when a climb cut is first started, the work has to be pushed into the cutter. Then the cutting action pulls the backlash out of the table leadscrew, and a heavier cut is taken than planned. If you understand and compensate for these drawbacks, climb milling can be used. However, for those new to milling, it is best to try and plan your cuts so that the end mill is cutting in the conventional manner.

WORKING TO SCRIBED LAYOUT LINES

A common practice when working with a mill is to lay out the hole centers and other key locations using a height gage and a surface plate. A coloring (usually deep blue) called layout fluid or “Dykem” is brushed or sprayed on a clean surface of the part. A thin layer is best because it dries quicker and won’t chip when a line is scribed. The purpose of this fluid is to highlight the scribed line and make it easier to see.

Don’t prick-punch the scribed, crossed lines representing a hole center. Using a center drill in the mill spindle and a magnifying glass, bring the headstock down until the center drill just barely touches the scribed cross. Examine the mark left with a magnifying glass and make any corrections needed to get it perfectly on center. You should be able to locate the spindle within .002” (.05 mm) of the center using this method.

Once the first hole is located in this manner, the additional holes can be located using the handwheels. (This is where the optional resettable “zero” handwheels are useful.) Now the scribe marks are used as a double check and the handwheels take care of the accuracy. Don’t forget the rules of backlash—always turn the handwheels in the same direction as you go from one point to the next.

USING A DIAL INDICATOR

(NOTE: For more on use of a dial indicator to square up your mill, see pages 13-16.)

The basis of most accurate machining involves the use of a “universal dial test indicator”; a small, inexpensive indicator which is calibrated in .001” or .01 mm divisions. An indicator with a large face or one that reads in finer divisions is not necessary for use with this mill. Three major tasks that can be accomplished with an indicator are:

1. Checking the squareness of a setup.
2. Finding the center of a hole.
3. Aligning the work with the machine.

A vise can be mounted or a part can be clamped down exactly parallel with the machine slides by holding the test

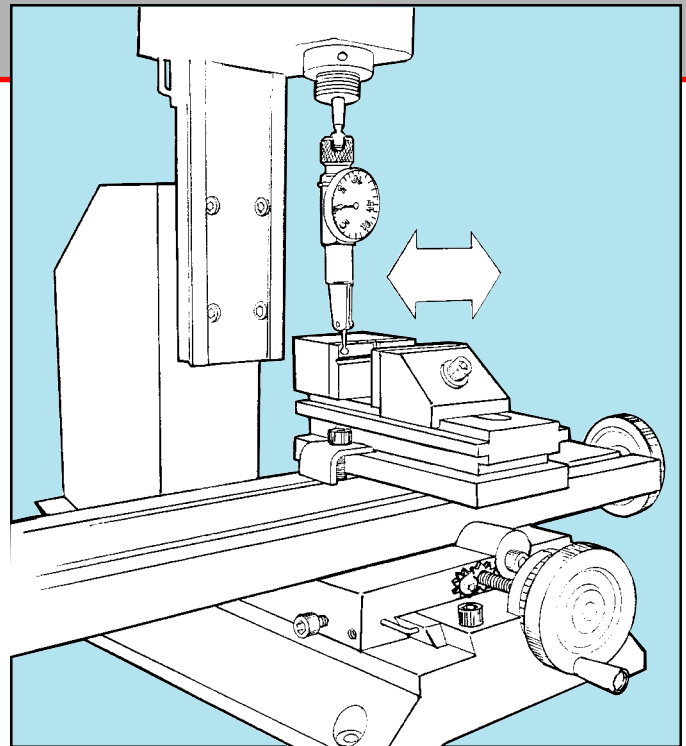

FIGURE 54—Indicating in the jaws of a vise. Shown is a Starrett “Last Word” Indicator. Starrett gages are available in numerous sizes and types. They are manufactured in Athol, Massachusetts and can be purchased from most industrial dealers.

indicator stationary and moving the slide with which you wish to align the part. When “indicating in” a vise, always take the reading on the fixed jaw. To start with, use approximately .005” indicator deflection from neutral. Remember that excessive pressure can cause inaccurate readings. Also, try to keep the indicator finger at a

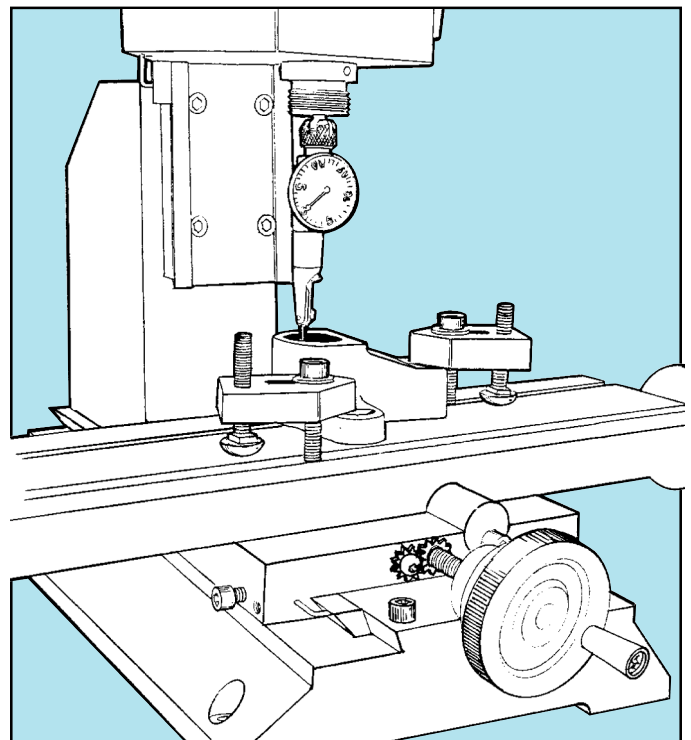

FIGURE 55—Indicating in the center of a hole

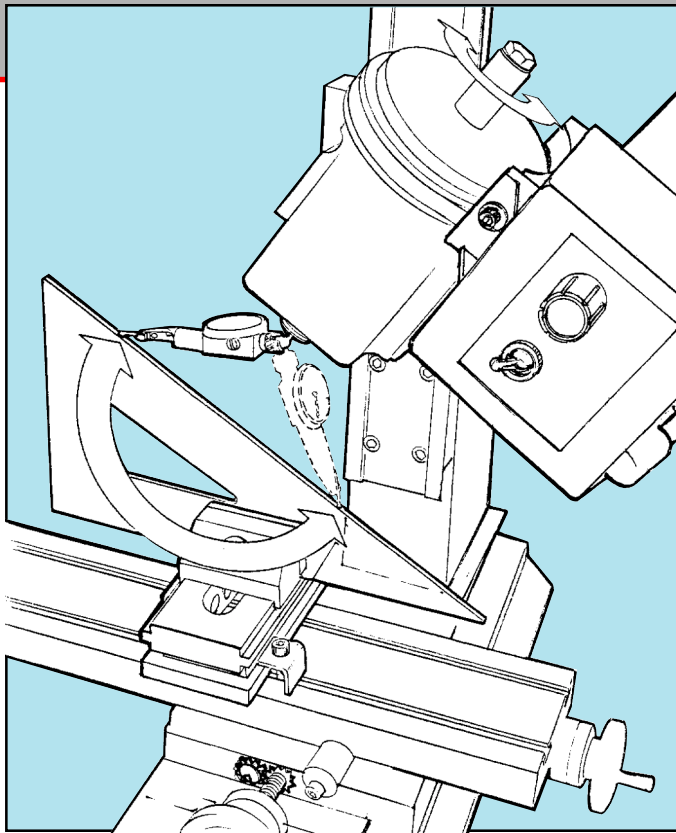

FIGURE 56—Indicating in a head tilt using a mill vise and draftsman's triangle

reasonable angle to the indicated part or surface. When the part is properly aligned, there will not be any deflection on the indicator. If you wish to locate the spindle over an existing hole, place the indicator in the spindle and read the inside surface. Move the X- and Y-axes until there is no deflection when the spindle is rotated. At this point, the spindle is in perfect alignment with the hole's center.

When aligning the spindle to used bearing holes, remember that the hole may be worn out-of-round, and it may be impossible to attain zero indicator deflection reading. Boring out a worn bearing hole to a larger diameter and sleeving it with a simple bushing made on a lathe is a fairly common machining operation. With the new bushing pressed in, the bearing will be like new.

The squareness of your machine may also be checked with an indicator. For instance, alignment of the head can be checked by offsetting the indicator in the spindle so the tip will move on about a 5-inch diameter circle. The amount of reading relative to the table is the amount of error. Don't be discouraged to find a few thousandths of an inch error in your machine. This machine has been designed to have the most accuracy commensurate with reasonable cost. In machine tool manufacturing, accuracy and cost run hand-in-hand. To increase accuracy only a few percentage points could double the selling price, because entirely different manufacturing processes would be required. However, you can personally improve the accuracy of your machine with a few shims, if needed, by employing your dial indicator.

The column bed is aligned with the column block at the factory. If you remove it, it will have to be realigned by mounting a known "square" on the mill table and adjusting

placement of the bed by running an indicator on the square as the headstock is raised and lowered. (See Figure 21, page 16.) The same method can be used to check alignment of the column bed to ensure it is square with the Y-axis. To correct any error (which should be small), place a shim between the column block and the mill base.

LOCATING THE EDGE OF A PART IN RELATION TO THE SPINDLE

There are two quick methods of "picking up an edge" of a part on a mill. The first is to put a shaft of known diameter in the spindle and see that it runs perfectly true. Using a depth micrometer against the edge of the part, measure the distance to the outside diameter of the shaft. To that dimension add half the known shaft diameter. You now have the distance from the edge of the part to the centerline of the spindle. Rotate the handwheel on the axis being set exactly this distance and you will have the centerline of the spindle lined up with the edge of the part from which you measured.

The second method is much easier. It involves the use of a clever tool called an "edge finder." These devices have been around for years and have two lapped surfaces held together by a spring. One surface is on the end of a shaft that fits in a 3/8" end mill holder and is held in the spindle. The other is a .200" diameter shaft held to the larger shaft with a spring so it is free to slide around. With the spindle running at approximately 2000 RPM, the shorter shaft will be running way off center. As this shaft is brought into contact with the edge you are trying to locate in relation to the spindle, the .200" shaft will be tapped to the center as the spindle rotates. This keeps making the .200" shaft run continually truer. When the shaft runs perfectly true it makes contact with the part 100% of the time. This creates a drag on the surface of the shaft that will "kick" it off center. (See Figure 57.) At this point you know the part is exactly .100" (half the diameter) from the centerline of the spindle. Advancing the handwheel on a Sherline mill two revolutions (.050" per revolution) will bring the edge of the part into alignment with the spindle.

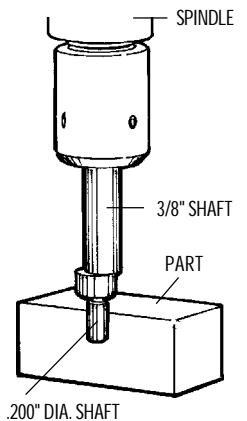

FIGURE 57—Using an "edge finder" to accurately locate the edge of a part

It is important to use a high quality edge finder such as the Starrett 827A shown in the drawing. It must have a 3/8" shaft to fit the end mill holder on the Sherline mill. Metric sized edge finders are also available which work in the same manner.

For those who like to own the newest gadgets, electronic edge finders are now available. Import models start at around \$100.00.



FIGURE 58—A digital readout makes life easier for the machinist. The electronic display reads out to .0005" and any axis can be reset to "zero" with the push of a button. It also helps eliminate mistakes due to losing track of the number of handwheel revolutions on longer dimensions. As a bonus, the spindle RPM is displayed at all times. The digital readout or "DRO" is available for both the lathe and mill.

DETERMINING DEPTH OF CUT

There are no firm rules other than common sense for determining depth of cut. A .030" cut depth with a 3/16" end mill in aluminum could be considered light, but .003" cut depth in steel with a 1/32" diameter end mill would break the cutter. Start with very light cuts and gradually increase the depth until satisfactory results are achieved. Try to develop the skill of knowing how much of a cut is satisfactory without breaking the cutter or damaging the work.

Note that regular end mills should not be used for drilling; however, they may be employed to enlarge an existing hole. The cutting edges deserve more respect than those of drills even though similar in appearance; they are designed to cut with their sides. Handle and store them with care.

WORK ACCURATELY

It should be remembered that a good machinist is capable of making a part to much closer tolerances than those of the machine with which he is working. The accuracy of the parts you make is limited only by your skill as a craftsman and the quality of your measurement equipment. Accuracy should be the ultimate goal of every machinist!

MACHINING TIP

Use of a tooling plate (P/N 3560) is an inexpensive way to protect the surface of your mill table while providing a flat, versatile clamping surface.

CUTTING SPEEDS FOR MILLING

SPEED ADJUSTMENT CHART

$$\text{SPINDLE RPM} = \frac{3.82 \times \text{S.F.M.}}{D}$$

S.F.M. = The rated Surface Feet per Minute for milling. For drilling, use 60% of the rated surface feet.

RPM = The rated spindle speed in Revolutions Per Minute

D = The Diameter of work in inches

FIGURE 59—Formula for adjusting spindle speed for cutting a given diameter.

NOTE: To estimate RPM, remember that the speed range of your vertical mill is from 0 to 2800 RPM. (The lowest usable speed is about 70 RPM, so we use that in our specifications. To obtain much more torque at the lower speed ranges, the drive belt can be switched to the smaller diameter positions on the spindle and drive pulleys.) Therefore, in the normal belt position, half speed is approximately 1450 RPM and so on. You can estimate these speeds by a combination of the setting on the speed control knob and the sound of the motor itself. When using the optional digital readout (P/N 8100), the exact RPM is displayed constantly on the LCD screen.

END MILLS

End mills are the standard cutting tools used on a vertical mill. We recommend 3/8" shank end mills held in the 3/8" end mill holder (P/N 3079). One of the benefits of 3/8" end mills is that they are available in a large range of sizes. The end mill is held with a set screw on its flat surface, and it can be easily changed. They are also lower in price than miniature cutters because of their popularity.

You can also use miniature series end mills having 3/16" or 1/4" shank sizes which should be held in collets or end mill holders sized for those tools. End mills held in collets must be single-ended, while end mill holders are capable of holding double-ended end mills. We recommend using 2-flute, high-speed steel (HSS) end mills for aluminum because the flutes are less prone to clog with chips. Use 4-flute cutters for cutting steels with lower RPM. The solid carbide tools are not suggested since they are very expensive and the cutting edges will chip unless used with heavy-duty production equipment.



FIGURE 60—A typical 2-flute end mill.

As a convenience to our customers, Sherline keeps in inventory many of the popular sizes of end mills that are appropriate for use on our machines. See the "Cutting Tools Price List" for selection. End mills may also be purchased from your local industrial machine shop supply outlet (see the yellow pages under "Machine Shop Supplies") or from mail order industrial suppliers.

Because small diameter cutters (less than 1/8") are quite fragile, the largest diameter cutter possible for the job

END MILLS (Slot and side milling)

MATERIAL	CUT SPEED (S.F.M.)			
	1/8" DIA.	1/4" DIA.	3/8" DIA.	
Stainless Steel, 303	40	1200 RPM	600 RPM	400 RPM
Stainless Steel, 304	36	1100	500	350
Stainless Steel, 316	30	900	450	300
Steel, 12L14	67	2000	1000	650
Steel, 1018	34	1000	500	350
Steel, 4130	27	800	400	250
Gray Cast Iron	34	1000	500	350
Aluminum, 7075	300	2800	2500	2000
Aluminum, 6061	280	2800	2500	2000
Aluminum, 2024	200	2800	2500	2000
Aluminum, Cast	134	2800	2000	1300
Brass	400	2800	2800	2800

DRILLS

MATERIAL	CUT SPEED (S.F.M.)	1/16" DIA.	1/4" DIA.
Carbon Steel	36	2000 RPM	550 RPM
Cast Iron, Soft	30	1800	450
Stainless Steel	24	1400	360
Copper	72	2000	1100
Aluminum, Bar	240	2000	2000
Aluminum, Cast	120	2000	2000

FIGURE 61—Drill and mill speed adjustment chart.

requirements should be employed. Be certain that the RPM is appropriate before attempting to remove any metal. An end mill can be instantly damaged if a cut is attempted at excessive RPM. Like all cutting tools, end mills will have a short life span when used for machining steel or other exotic materials. Save new cutters for finish work. Because of excessive cutter deflection (bending), do not use small diameter end mills with long flutes unless absolutely necessary.

RESHARPENING END MILLS

End mills can be resharpened by your local tool and cutter grinding shop. End mills lose their cutting edge clearance after a couple of sharpenings and should no longer be reused.

USING THE MILL COLUMN SADDLE LOCK

The saddle locking lever is located on the back side of the mill column just above the saddle nut. This lever tightens against the saddle nut on the column leadscrew to keep it from moving during milling operations.

With the lever released, adjust the Z-axis handwheel to the desired setting. Rotate the lever counterclockwise to lock the saddle. This will eliminate any backlash in the leadscrew. Friction on the gib can still cause a little backlash to be present between the handwheel and the leadscrew thrust. To eliminate this, push down on the saddle to make sure the handwheel is fully seated against the thrust. Double check your height adjustment. Now, when milling, the saddle cannot move any further down.

To release the saddle, rotate the lever clockwise. A spring-loaded ball in the saddle fits in a detent on the lever to keep it from locking accidentally when the Z-axis is adjusted. (See Figure 62.)

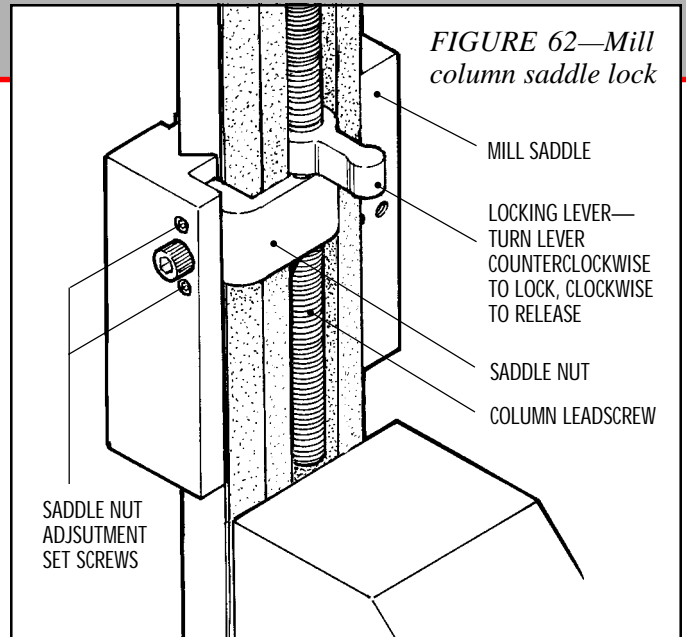

FIGURE 62—Mill column saddle lock

ACCESSORIES FOR MILLING

The addition of accessories can greatly enhance the utility of your mill. A few of the more popular accessories are described below.



Fig. 63

SENSITIVE DRILLING ATTACHMENT (P/N 1012)

The sensitive drilling attachment provides both faster drilling of multiple holes and better “feel” for the cut when using drills smaller than 1/16". A Jacobs 5/32" drill chuck is fitted to a spring loaded shaft that inserts into the spindle. A red knurled collar with a ball bearing at the center, allows the user to hand feed the chuck. A spring inside the brass tube helps return the chuck to the up position when done. The chuck holds drills from 5/32" (4 mm) down to #80 or smaller. The attachment is easily installed by screwing it onto the external thread of the spindle.

3/8" END MILL HOLDER (P/N 3079)

The 3/8" end mill holder makes it easy to use the popular (and less expensive) 3/8" end mills. Using double-ended end mills is economical and easy with this holder, as tools

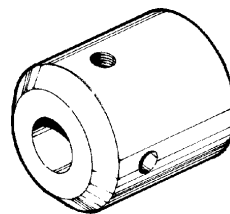

FIGURE 64—3/8" End mill holder

are changed by simply loosening a set screw and changing the tool. Sherline now offers holders to hold other size cutting tools in the same manner. The following additional sizes are available: 3/16" (P/N 6080), 1/4" (P/N 6079), 5/16" (P/N 3075), 6.0mm (P/N 3076), 8.0mm (P/N 3077) and 10mm (P/N 3078).

MILL COLLET SET (P/N 3060)

(See Figure 65 on next page.) The main purpose of the mill collet set is to hold end mills. The spindle nose has an internal Morse #1 taper that closes the collet as the drawbolt is tightened. Morse tapers are approximately 5/8" per foot and are self-locking. Therefore, to loosen a collet, the drawbolt must be loosened a few turns and given a few **light** taps with a hammer.

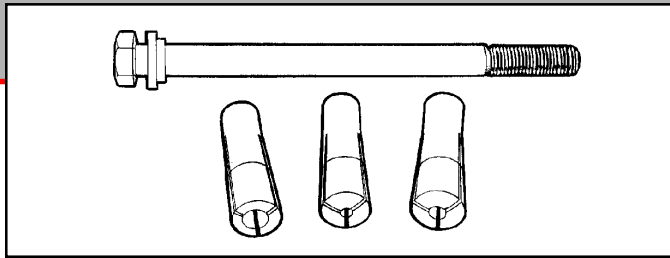

FIGURE 65—Mill collet set

BORING HEAD (P/N 3054/3049) AND BORING TOOLS

The main purpose of the boring head is to eliminate the need for a large inventory of drills and reamers. A small milling machine would not have the power or rigidity to turn a one-inch diameter drill even if one could be obtained that would fit. However, holes of even larger diameters can be accurately bored to size with a little patience and care.

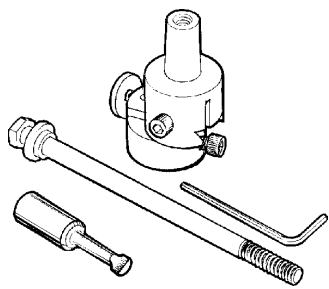

FIGURE 66—Boring Head and Boring Tool. Boring tool P/N 3061 is for 1/4" (6.4 mm) minimum diameter by .60" (15.2 mm) maximum depth hole. P/N 3063 is for 5/16" (7.0 mm) minimum diameter by 1.0" (25 mm) maximum depth hole. Both have a

3/8" diameter shaft. P/N 3064 is similar in size to P/N 3063 but longer and will work to a maximum depth of 1.5" (38.1 mm).

Boring heads for the mill work on the same cutting principle as lathe boring, except that the cutting tool turns while the work remains stationary. (In the case of a lathe, the work turns and the cutter remains stationary.) The boring head is designed to employ round cutting tools with a 3/8" shank. Sherline offers three boring tools with sizes and lengths appropriate for the Sherline mill. It is sometimes advisable to remove excessive tool shank length from standard (non-Sherline) 3/8" boring tools in order to improve rigidity. (See Figure 52, page 32 for a boring tool in use.)

Tool sizes are listed indicating the smallest diameter hole that can be bored and the maximum depth that can be cut. For best results, use the largest diameter possible with the shortest lengths. A .010" cut represents a good starting point.

If boring a hole where a flat bottom is required, it is advisable to stop the down-feed at about .002" above the desired depth, turn off the motor and cut the remaining distance by hand-turning the spindle to eliminate any possibility of chatter.

FLY CUTTERS (P/N 3052 AND P/N 7620)

For machining flat surfaces, the fly cutter shown in the *Sherline Tool & Accessory Catalog* is recommended. It is imperative that the tool be used with utmost care. EYE PROTECTION IS A MUST, and the work as well as the cutting tool must be properly held. The big advantage of a fly cutter is its ability to take light cuts up to 2" wide and to give an excellent surface finish. It is ideal for squaring

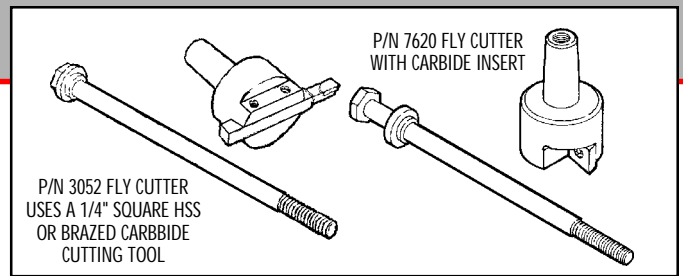

FIGURE 67—Fly cutters and drawbolts

up work. Also, the machining stresses are lower than one might imagine, because, unlike an end mill, very little crushing action takes place at the cutting edge. Fly cutting tools look like left-hand lathe tools, and, although the fly cutter (P/N 3052) comes with a brazed carbide tool, high-speed tools work quite well and can be sharpened on any grinder. (See Figures 67 and 68)

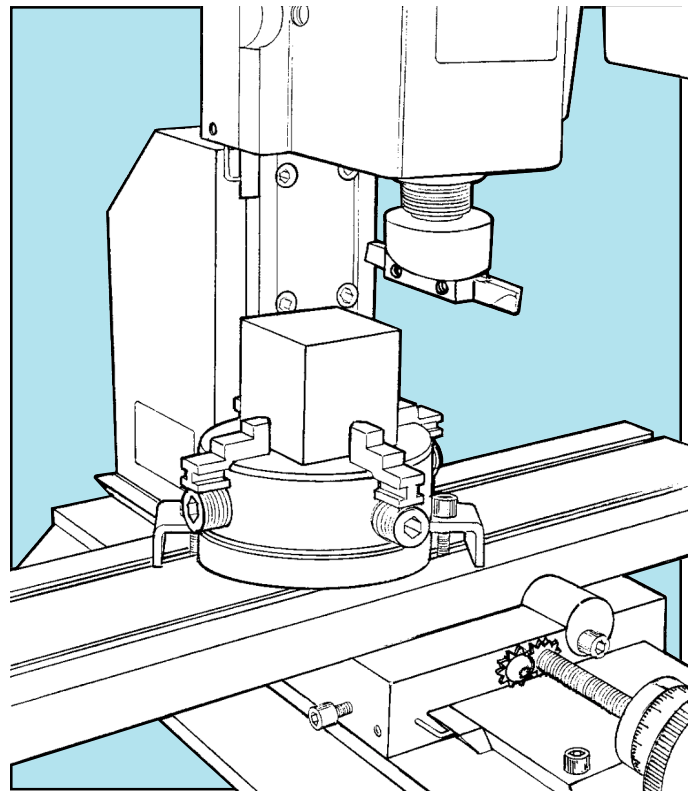

FIGURE 68—Typical setup for fly cutting

DRILL CHUCK (P/N 3072) AND CENTER DRILLS

The 1/4" drill chuck available for this vertical mill is supplied complete with a #1 Morse arbor and a drawbolt to hold it securely in place. Drilling can be accomplished by raising and lowering the entire head with the vertical feed handwheel. This allows for very accurate control of feed rate and hole depth. For accurately located holes we again stress the importance of using center drills.

Drills should be kept in excellent condition, either by replacement or proper resharping. Good quality high-speed steel drills should be employed. A dull or improperly sharpened drill can cut oversize by as much as 10%. When you start to drill, the initial penetration should be no more than twice the diameter of the hole before you retract the drill, clear the chips and add coolant with the tip of a small brush. From then on, do not try to drill deeper than the

diameter of the drill without clearing the chips and adding coolant. For example:

To drill a 1/8" diameter hole 1" deep:	Total Depth
1st Pass: 2 times diameter or 1/4"	1/4"
2nd Pass: 1 times diameter or 1/8"	3/8"
3rd Pass: 1 times diameter or 1/8"	1/2"
Etc.	

(You may encounter recommendations exceeding this, but they are meant for automatic equipment with pressurized coolant systems.)

It is difficult to maintain tolerances of better than +.003" –.000" with a drill. If tolerances closer than these are required, a reamer must be employed. Try to use fractional size reamers whenever possible rather than decimal sizes, because the cost difference can amount to 2 or 3 times higher for decimal sizes. (The length of reamers may prevent their use for some operations on machines of this size.)

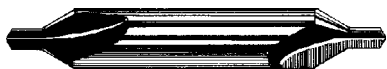

FIGURE 69—Typical Center Drill

To accurately start holes, center drills must be used. They have a small tip that accurately starts the hole, and then the shaft widens with a 60° cutting face to the final diameter. Care must be taken to employ cutting oil and to clear chips from the drill frequently. If this is not done, the fragile tip may load up and twist off, even in soft materials. Center drills are available in a variety of sizes, but for general work we recommend size No.1.

SIZE	BODY DIA.	DRILL DIA.	DRILL LENGTH	LENGTH OVERALL
000	1/8"	.020"	3/64"	1-1/4"
00	1/8	.025	1/16	1-1/4
0	1/8	.031	1/16	1-1/4
1	3/16	.046	3/64	1-1/4
2	3/16	.078	5/64	1-7/8
3	1/4	.109	7/64	2

FIGURE 70—Table of commonly available center drill sizes

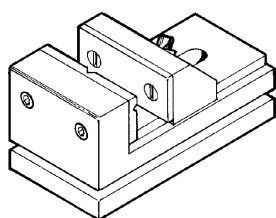

FIGURE 71—Mill vise

MILL VISE SET (P/N 3551)

The vise shown here and in use in Figures 54 and 56 is furnished with special clamps that allow it to be clamped in any position on the mill table. The vise capacity is 2 inches. It has a movable jaw that is pulled down while clamping, eliminating any chance for the jaw to lift. Perpendicular grooves in the fixed jaw help secure round stock. It is the most convenient way to hold small parts for milling. Now available for the

mill vise is a rotating base (P/N 3570) that greatly adds to the versatility of this basic machining accessory.

mill vise is a rotating base (P/N 3570) that greatly adds to the versatility of this basic machining accessory.

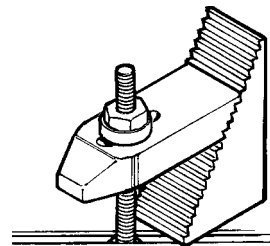

FIGURE 72—Step block hold-down set

STEP BLOCK HOLD-DOWN SET (P/N 3013)

When a part can't be held in a mill vise due to its size or shape, the step block set is the next most popular way machinist's have traditionally clamped work to the mill table. Its versatile design makes setups quick and easy.

The set includes two step blocks and two step clamps plus an extra unanodized step block that can be cut and milled to make smaller blocks to suit your special needs. Also included are six pairs of threaded studs from 1" to 3.5", T-nuts and special convex nuts and concave washers that tighten flat on clamps even if they are slightly tilted.

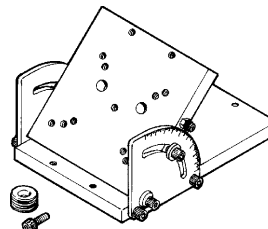

FIGURE 73—Tilting angle table

TILTING ANGLE TABLE (P/N 3750)

This accessory opens up a great variety of setup options. The table can be tilted to any angle from 0° to 90°. A hole pattern in the table is designed to easily mount the mill vise or rotary table for holding parts. A chuck adapter is included that allows the 3-jaw or 4-jaw chuck to be screwed directly to the table as well. Parts mounted to the table can be machined or drilled at precise angles without tilting the column or headstock. In the 90° position, the rotary table is held at the same height as it would be on the P/N 3701 right angle plate, eliminating the need for that accessory.

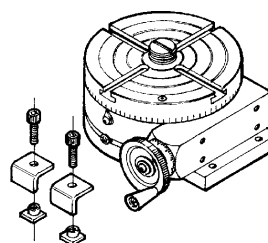

FIGURE 74—Rotary table

4" ROTARY TABLE (P/N 3700)

The rotary table mounts to the mill table and provides a rotary axis for milling. Each increment on the handwheel represents 1/10° of rotation, so a circle can be divided into 3600 segments without interpolation. Seventy-two handwheel revolutions rotate the table one time. It can be used to mill a radius on a part, cut a circular slot or drill precision circular hole patterns. Used with the right angle attachment (P/N 3701) and right angle tailstock (P/N 3702), it can also be used to cut gear teeth. A rotary table used with a mill allows a machinist to produce virtually any part he can design. On a Sherline mill, the only limits are size, not complexity. The compact size of this high quality rotary table also makes it a good choice for use on larger machines as well, where its size would offer an advantage in working with small parts. (See Figure 51 for a photo of the rotary table in use.)



FIGURE 75—This simple programmable indexer brings computer control to operations like cutting gears.

CNC ROTARY INDEXER (P/N 8700)

Based on the 4" rotary table, this completely self-contained, computer operated unit is perfect for repetitive radial operations like gear cutting or drilling multiple hole patterns. Using the keypad, enter the parameters such as the number of divisions required. When the command is given, the indexer will move precisely to the next programmed position. The computer keeps track of the divisions to many decimal places, so error is virtually eliminated. The unit includes a computer/keypad unit, rotary table, motor mount, stepper motor, power supply and all connecting cables. It can also be "daisy chained" with other units to produce sequenced operations.

HORIZONTAL MILLING CONVERSION (P/N 6100) FOR 5000/5400-SERIES MILLS

A number of milling operations require the application of the cutting tool from the side rather than from the top. A 3/4" thick aluminum base 10.5" x 12.5" allows the 5000-series mill column to be mounted separately from the base for a variety of milling configurations. The headstock is rotated 90° and work is machined from the side, allowing larger surfaces to be worked on without having to reclamp



FIGURE 76—One of the configurations possible with the horizontal milling conversion, P/N 6100.

the work. (Note: The greater versatility and capacity of the 2000-series 8-direction mill eliminate the need for this accessory on those mills.)

The black anodized mounting plate is predrilled to mount the base and column in several possible locations. Alignment bars and a selection of appropriate bolts are included to make it easy to accurately relocate the column. Rubber feet insulate the table for quiet, vibration-free operation. (Note: The column base should be shortened by 2" for best operation. Instructions are provided with the accessory, or we can shorten your column for you. The modification is listed as P/N 6101 on the price list. New mills purchased along with the horizontal milling conversion can be ordered with the column already split.)



CNC-READY SHERLINE LATHES AND MILLS

FIGURE 77—Any Sherline lathe or mill can be ordered "CNC-ready," and existing machines can be easily converted to have stepper motors drive the leadscrews. Shown here is a cutaway of a stepper motor mount with two preloaded ball bearings and coupler.

Sherline now offers the stepper motor mounts and couplings needed to turn any Sherline lathe or mill into a computer-controlled machine. Several aftermarket companies offer complete CNC machines based on Sherline tools, but if you can come up with the software portion of the system, you can now build up your own stepper motor-equipped machine from Sherline components. An exploded view of a typical stepper motor mount and coupling is shown on page 41. A list of dealers selling Sherline CNC packages is available on Sherline's web site at www.sherline.com/cncdlrs.htm or by calling Sherline and requesting a CNC dealer list.

UPGRADING 5000/5400-SERIES MILL COLUMNS TO 8-DIRECTION CAPABILITY

Any existing Sherline mill can be upgraded to 8-direction capacity with the addition of a 2000-series column conversion. The rectangular column base is replaced by the round column, ram and rotating collar of the 2000-series 8-direction mill. A base adapter offsets the column to the rear to make up for the additional mechanism so that no Y-axis travel is lost. (See Figure 78, next page.)

FIGURE 78—The P/N 5650 (inch) or P/N 5660 (metric) upgrade includes everything you need to bring your existing Sherline mill up to the 8-direction capacity of the Model 2000 mill.

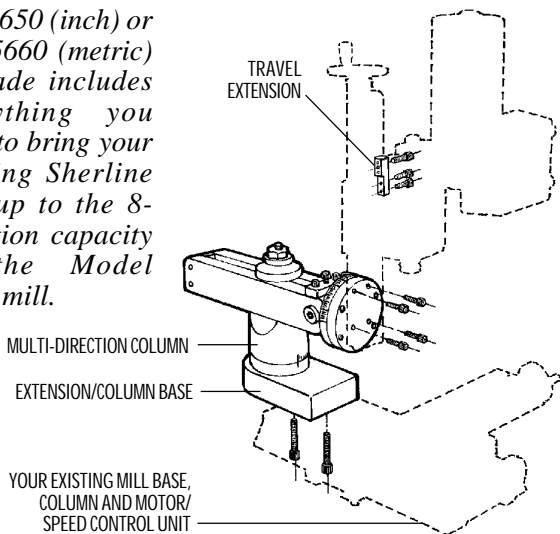

ADDITIONAL MILL ACCESSORIES

Following is a list of popular Sherline accessories for the mill and a brief description of their purpose. Part numbers for inch sizes are listed first with metric part numbers (when different) in parenthesis.



1187 Chuck-to-T-Slot Adapter—Slips in either T-slot on mill table and a 3- or 4-jaw chuck can be screwed down to hold parts for milling. (Shown upside down.)

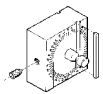

1297 Mill Headstock Spacer Block—Extends headstock 1.25" (31.8mm) further out to reach areas that otherwise could not be machined without changing your setup. Laser engraved scale for angle milling. Includes additional precision alignment key.

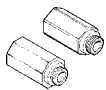

2045 Index block set—A hex block and an octagonal block make quick work of simple indexing operations involving 2, 3, 4, 6 or 8 increments. Internal Morse #1 taper and external threads accept all Sherline chucks and collets for holding parts.

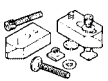

3012 Hold-down Set—Two strap clamps plus T-Nuts and a selection of bolts to provide a versatile method of clamping work to the mill table. See also the newer P/N 3013 step block hold-down set shown in Figure 72, page 38.

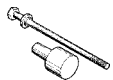

3055 Morse #1 Blank—Made from free-machining steel. Make your own custom tool holders. Drill, tap or slot this blank to fit your custom needs.

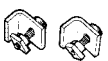

3058 4-Jaw Hold-down Set—Two T-nuts, bolts and clamps to mount a Sherline 4-jaw chuck in just about any location on the mill table for holding parts. (Included with mill vise and rotary table.)

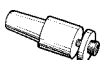

3065 Slitting Saw Holder—Holds jeweler's circular slitting saw blades for machining thin slots.



3080 End Mill Set—Three 3-flute end mills, sizes 1/8", 3/16" and 1/4". All have 1/4" shank.

Other sizes are available individually, see the "Cutting tools price list."

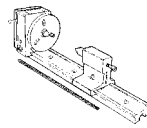

3200 Indexing Attachment—Cut gears of any number of teeth or drill precise hole patterns. The indexing head and tailstock are mounted on a 12" dovetailed bed. Includes a gear cutter holder and cutting tool blank. The head detents every 5° of rotation or a special rack gear allows division of a circle into any number of increments by measuring rack length.

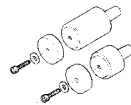

3230-3236 Mill Cutter Arbors—Available in 7/8" or 1" I.D. sizes and long or short lengths, these arbors are designed to hold round milling cutters.

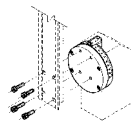

3500 Rotary Column Attachment—Allows the mill column to be rotated up to 90° either way side-to-side so that angled drilling or milling can be accomplished.

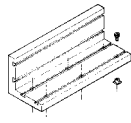

3559 90° Angle Plate—This useful work-holding fixture can be used to hold parts on either surface, and parts can also be held from two directions at once. It is 3-5/8" x 3-5/8" x 10" and has T-slots on both surfaces.

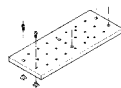

3560 Mill Tooling Plate—Cast aluminum plate milled to 1/2" thick provides a versatile method of clamping parts to the table. Use existing threaded 10-32 holes or drill and tap your own as needed. Protects the table surface and also adds stiffness to the mill table. Includes mounting bolts and T-nuts.

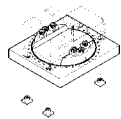

3570 Rotating Vise Base—When mounting the mill vise to the table, this base will allow the vise to be rotated to any angle. The red anodized base is laser engraved with angle measurements in 1° increments all the way around.

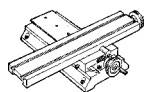

XY Bases—Mill base and table only. If you already have a lathe and vertical milling column, this is all you need to make up a complete mill at less cost. Available in standard 10" base (P/N 5200/5210), 10" base with adjustable handwheels (P/N 5220/5225) or deluxe 12" base with laser engraved scales and adjustable handwheels (P/N 5401/5411). The 2000-series 14" base is also available (P/N 5600/5610) so that an 8-way column can be added to make it a complete 2000-series mill. Uses lathe motor and speed control.

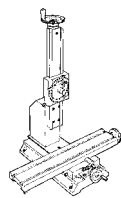

XYZ Bases—A complete 3-axis mill less the headstock, motor and speed control. Available in standard 10" base (P/N 5201/5211), 10" base with adjustable handwheels (P/N 5230/5235) or deluxe 12" base with laser engraved scales and adjustable handwheels (P/N 5420/5430). The 8-way 2000-series mill base and column is available as well (P/N 5625/5630).

5150 and 5151 Vinyl Dust Covers—Fitted 6-mil vinyl cover keeps mill clean and dust free when not in use. P/N 5150

5329—Shop Secrets Video—Measuring Tools, by Mike Rehmus. A great introduction to the proper use of measuring tools for machining. 2 hours, VHS

fits 5000-series mills, while P/N 5151 is sized for 2000-series mills.

8100 (8160) Mill Digital Readout—3-axis digital readout can be added to any existing mill or ordered factory installed on any new mill. Reads to .0005" or .01 mm. Resets to zero with the push of a button. Also reads out spindle RPM at all times. See photo on page 35.

BOOKS AND VIDEOS

Sherline Shop Guide—This collection of instructions from all Sherline's major accessories is a great source of machining information and a good way to learn about an accessory before you decide to buy. 8-1/2 x 11", 202 pages, P/N 5327

Steam Engine Video—Rudy Kouhouth shows production of a scratch built steam engine from start to finish. Includes dimensioned plans and materials list. Watch an expert as you learn machining skills, build confidence and end up with a beautiful, working steam engine for your den or coffee table. 2 tapes, 3-1/2 hours, VHS, P/N 5328

Home Machinist's Handbook—Doug Briney's book features Sherline equipment throughout. It is a complete guide for the amateur machinist and covers all aspects of lathe and mill use as well as information on reading plans, measuring, using hand tools, selection of materials, heat treating and so on. It also includes practice projects such as punches,

ball peen hammers, gages, a cannon and more. Softbound, black and white, 7-3/4" x 9-1/4", 275 pages, P/N 5300



Tabletop Machining—

Sherline's owner, Joe Martin has written the most complete and up-to-date book ever on machining small metal parts. Its high-quality format makes it equally at home on the coffee table or workbench. Naturally, Sherline tools are featured. Softbound or hardbound, full color, 8-1/2" x 11", 344 pages, over 400 color photos and over 200 illustrations, P/N 5301

PARTS FOR SHERLINE CNC-READY LATHES AND MILLS

Sherline CNC-ready lathes and mills use the same components as are used on standard Sherline machines with the exception of the parts shown here. Handwheels that would normally come with the machines are included for use on the end of the stepper motors. Where different, inch part number is shown first followed by the metric part number.

CNC STEPPER MOTOR MOUNT EXPLODED VIEW

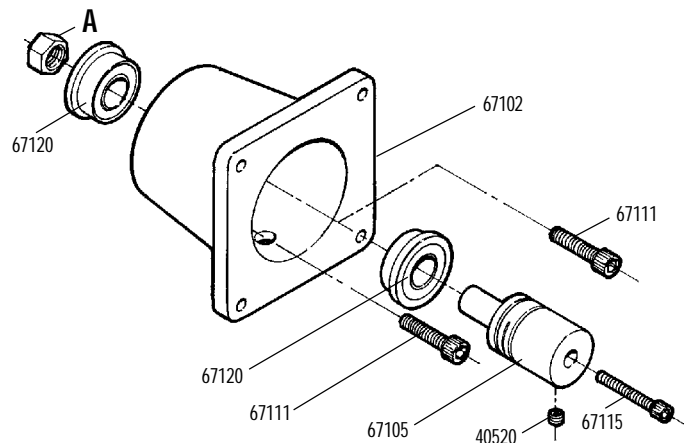

FIGURE 80—Exploded view of typical Sherline stepper motor mount components

REF.	PART NO.	PART DESCRIPTION	USE
A	67106/67108	RH preload nut	Lathe crossslide screw, Mill X-axis
A	67107/67109	LH preload nut	Lathe leadscrew, Mill Y- and Z-axes

Other Parts used only on CNC-Ready machines

PART NO.	DESCRIPTION
50171/51171	All Mills, X-axis CNC leadscrew
54161/54171	All Mills, Y-axis CNC leadscrew
67028/67029	5000/5400 Mills, Z-axis CNC leadscrew
67030/67031	2000 Mill, Z-axis CNC leadscrew
67024/67025	4000 Lathe, 15" CNC leadscrew
67026/67027	4400 Lathe, 24" CNC leadscrew
44211/44222	All lathes, 6.5" CNC slide screw
67040/67041	CNC Lathe bed hold-down

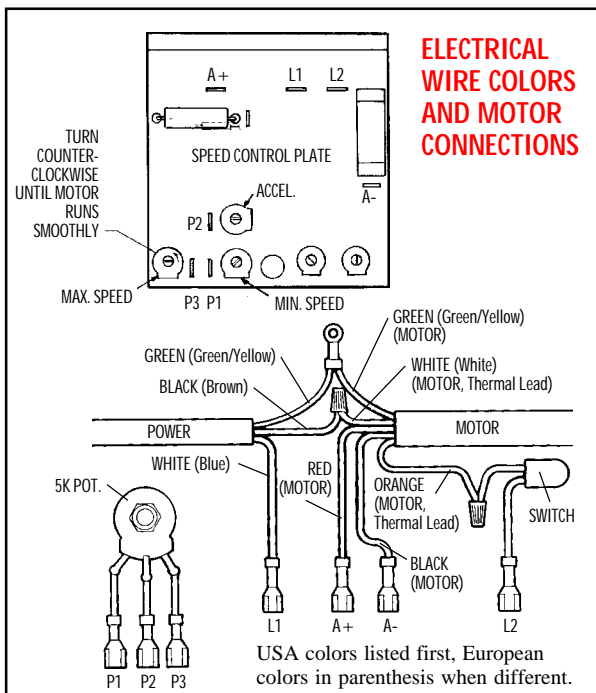

FIGURE 79—Electrical wiring color codes for motor and speed control

SHERLINE FACTORY TOURS

Visit Sherline's factory in North San Diego County and see miniature machine tools being produced. If you can't come by, see the photo factory tour on our web site at www.sherline.com/factour.htm.

SHERLINE LATHE EXPLODED VIEW AND PART NUMBER LISTING

NOTE: Where different, Inch part number is given first, followed by Metric part number.

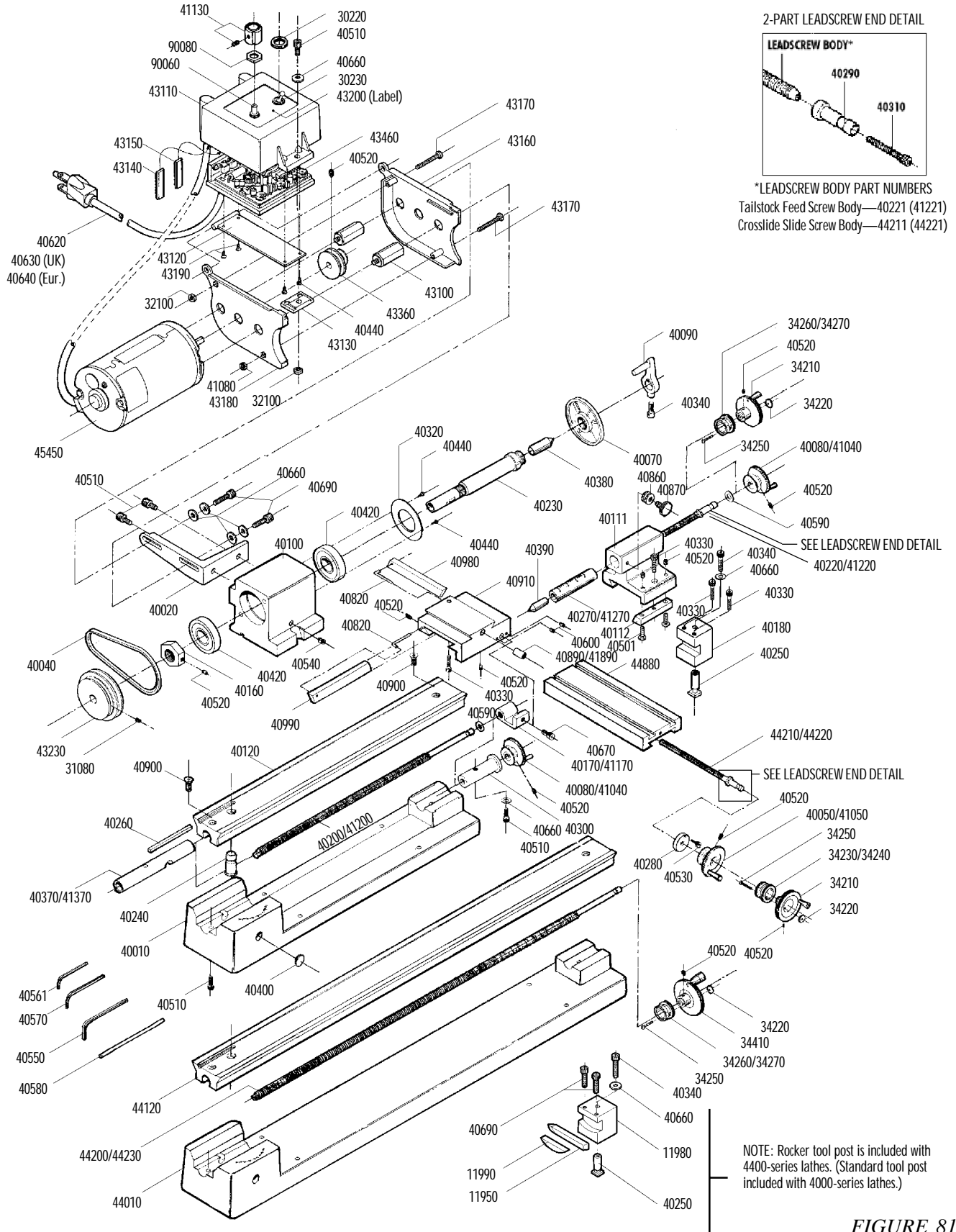

FIGURE 81

SHERLINE VERTICAL MILLING MACHINES EXPLODED VIEW AND PART NUMBER LISTING

NOTE: Where different, Inch part number is given first, followed by Metric part number.

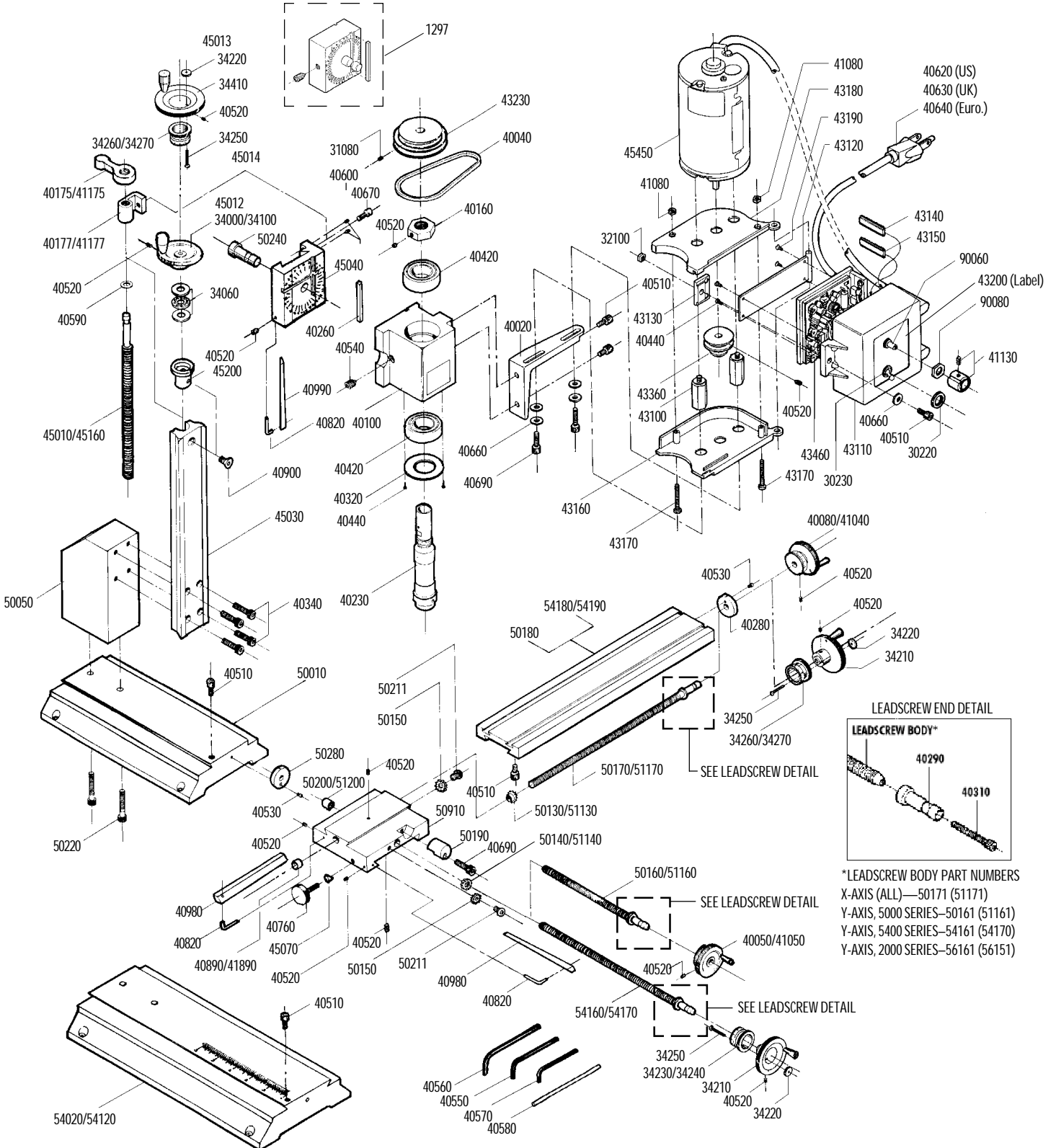
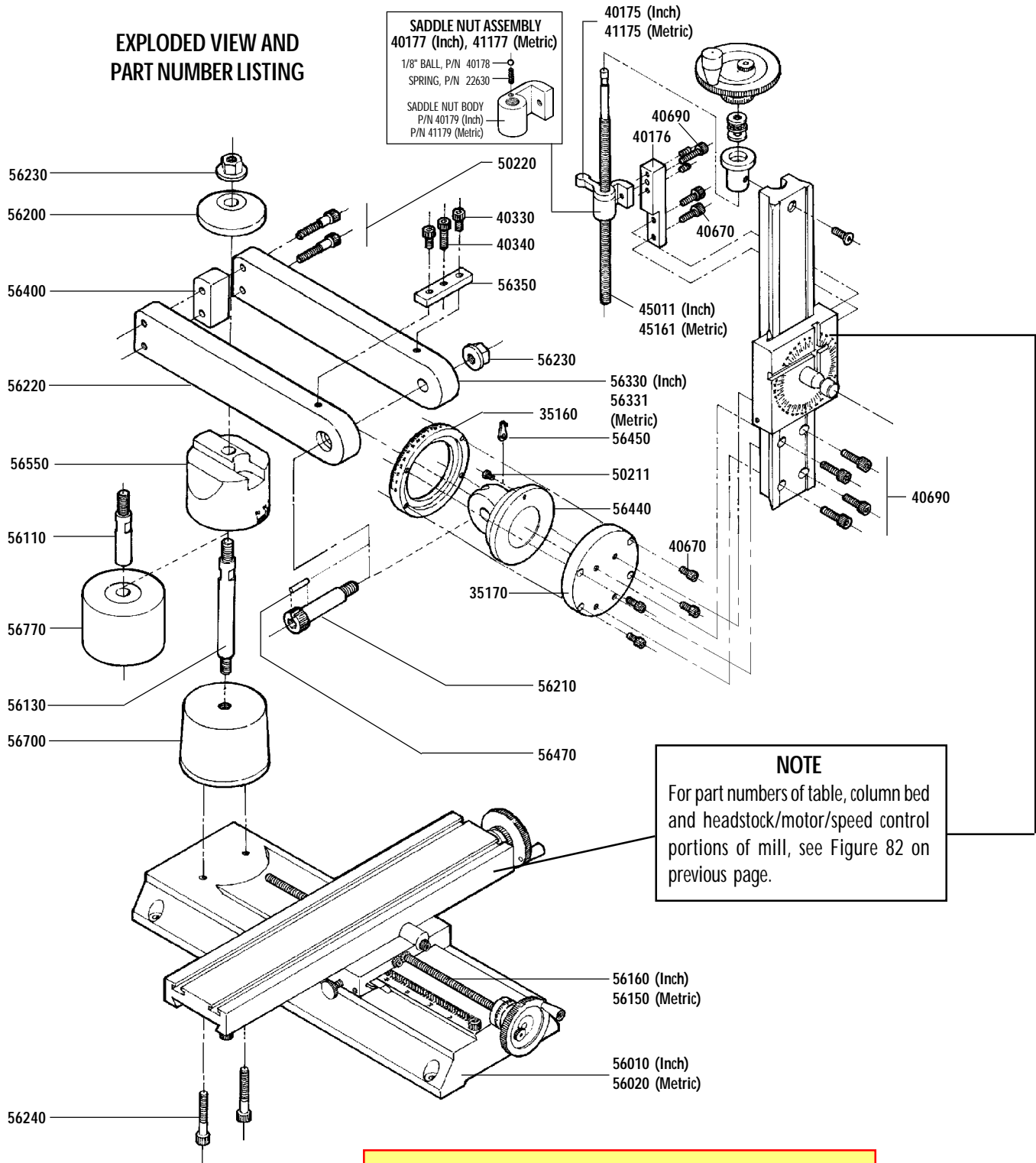

FIGURE 82

SHERLINE MODEL 2000 MILL COLUMN

EXPLODED VIEW AND PART NUMBER LISTING



NOTE
 For part numbers of table, column bed and headstock/motor/speed control portions of mill, see Figure 82 on previous page.

NEW SHERLINE ACCESSORIES
 Sherline introduces new accessories every year. See our web site for new product introductions.
www.sherline.com

FIGURE 83

PART NUMBERS AND DESCRIPTIONS, SHERLINE LATHES AND MILLS

KEY TO MATERIALS: A=Aluminum, B=Brass, C=Composite, DC=Die Cast, P=Plastic, U=Urethane, S=Steel

PART NO.	DESCRIPTION	MATERIAL	PART NO.	DESCRIPTION	MATERIAL	PART NO.	DESCRIPTION	MATERIAL
1195	1/4" HSS Right hand cutting tool	S	40560	3/16" Hex Key	S	50170	Leadscrew, X-axis (Inch)	S
11980	Rocker tool post body	A	40570	3/32" Hex Key	S	50171	CNC Leadscrew, X-axis (Inch)	S
11990	Rocker tool post rocker	S	40580	Spindle Bar	S	50180	Mill Table	A
1297	Headstock Spacer Block (Deluxe Mill)	A/S	40590	1/4" I.D. Washer	S	50190	X-axis Lock	S
22630	Spring (in Z-Axis Saddle Nut)	S	40600	10-32 x 1/4" Flat Point Set Screw	S	50200	Nut, Y-axis (Inch)	B
30220	Toggle Switch Retaining Ring	S	40620	Power Cord, USA	--	50210	8-32 x 1/4" Pan head Screw	S
30230	Toggle Switch	--	40630	Power Cord, UK	--	50211	8-32 x 1/4" Button Head Screw	S
31080	10-32 x 3/8" Flat Point Set Screw	S	40640	Power Cord, Europe	--	50220	1/4-20 x 1-3/4" Socket Head Cap Screw	S
32100	10-32 Hex Nut	S	40660	3/16" I.D. Washer	S	50240	Headstock Pivot Pin, Mill	S
34000	Oversize Handwheel (Inch)	A	40670	10-32 x 1/2" Socket Head Cap Screw	S	50280	Thrust Collar, Mill	S
34060	Thrust Bearing Washer Set	Ball	40690	10-32 x 3/4" Socket Head Cap Screw	S	50910	Saddle	A
34100	Oversize Handwheel (Metric)	A	40760	10-32 x 5/8" Thumbscrew	S	51130	Backlash Nut, X-axis (Metric)	B
34200	2" Zero Adjustable Hndwhl. Asby., (Inch)	A/S	40820	Gib Lock	S	51140	Backlash Nut, Y-axis (Metric)	S
34210	2" Handwheel Body	A	40860	Tailstock Locking Screw Grommet	P	51160	Leadscrew, Y-axis (Metric)	S
34220	Handwheel Locking Nut	S	40870	Tailstock Spindle Locking Screw	S	51170	Leadscrew, X-axis (Metric)	S
34230	Y Axis/Crossslide Collar (Inch)	A	40890	Slide Screw Insert (Inch)	B	51171	CNC Leadscrew, X-axis (Metric)	S
34240	Y Axis/Crossslide Collar (Metric)	A	40900	10-32 x 3/8" Flat Head Socket Screw	S	51200	Nut, Y-axis (Metric)	B
34250	6-32 x 7/8" Pan Head Screw	S	40910	Saddle	A	54020	12" Mill Base, Deluxe Engraved (Inch)	A
34260	X, Z-axis and Leadscrew Collar (Inch)	A	40980	Gib, lathe crossslide, mill X- and Y-axes	C	54120	12" Mill Base, Deluxe Engraved (Metric)	A
34270	X, Z-axis and Leadscrew Collar (Metric)	A	40990	Gib, lathe saddle, mill Z-axis	C	54160	Leadscrew, Deluxe Mill, Y-axis (Inch)	S
34300	2" Zero Adjustable Hndwhl. Asby., (Met.)	A/S	41040	1-5/8" Handwheel, X-axis/Leadscrew (Metric)	A	54161	CNC Leadscrew, Deluxe Mill, Y-axis (Inch)	S
34400	2-1/2" Zero Adjust. Hndwhl. Asby., (Inch)	A/S	41050	1-5/8" Handwheel, Y-axis/Crossslide (Metric)	A	54170	Leadscrew, Deluxe Mill, Y-axis (Metric)	S
34410	2-1/2" Handwheel Body	A	41080	6-32 Hex Nut	S	54171	CNC Leadscrew, Y-axis Deluxe Mill (Metric)	S
34500	2-1/2" Zero Adjust. Hndwhl. Asby., (Met.)	A/S	41110	Tailstock Casing	A	54180	Mill Table, Deluxe Engraved (Inch)	A
35160	Graduated Clamping Ring	S	41130	DC Speed Control Knob and Set Screw	P/S	54190	Mill Table, Deluxe Engraved (Metric)	A
35170	Moveable Clamping Ring	S	41170	Saddle Nut	B	56010	#2000 Mill Base (Inch)	A
40010	15" Lathe Bed	DC	41177	Saddle Nut Assembly w/ Ball, Z-axis (Metric)	B	56020	#2000 Mill Base (Metric)	A
40020	Motor Bracket	DC	41179	Saddle Nut, Z-axis, w/o Ball or Spring (Metric)	B	56110	Extension Bolt	S
40040	Drive Belt	U	41200	15" Leadscrew (LH) (Metric)	S	56130	#2000 Arm Hold-down Bolt	S
40050	1-5/8" Handwheel, Y Axis/Crossslide (Inch)	A	41220	Feed Screw (Tailstock, LH) (Metric)	S	56150	#2000 Y-axis Leadscrew (Metric)	S
40070	Faceplate	DC	41270	Tailstock Spindle (Metric)	S	56160	#2000 Y-axis Leadscrew (Inch)	S
40080	1-5/8" Handwheel, X Axis/Leadscrew (Inch)	A	41890	Slide Screw Insert (Metric)	B	56200	#2000 Arm Hold-down Washer	A
40090	Drive Dog	DC	43100	DC Motor Standoff	A	56210	3/8-16 x 2" Shouldered Bolt	S
40100	Headstock Casing	A	43110	DC Speed Control Case	P	56220	#2000 Swing Arm Side	A
40111	Tailstock Casing (Gib style)	A	43120	DC Speed Control Hinge Plate	P	56230	Flange Nut	S
40112	Tailstock Gib	B	43130	DC Speed Control Cover Mounting Plate	P	56240	1/4-20 x 1-1/2" SHCS	S
40120	Lathe Bed	S	43140	DC Speed Control Tab, Small	P	56330	#2000 Swing Arm Side (Engraved)	A
40160	Preload Nut	S	43150	DC Speed Control Tab, Large	P	56350	Column Adjustment Block	A
40170	Saddle Nut (Inch)	B	43160	Belt Guard, Outer	P	56400	#2000 Arm Spacer Block	A
40175	Column Saddle Travel Extension	S	43170	6-32 x 1-3/8" Pan Head Screw	S	56440	#2000 Arm Mount	S
40176	Column Locking Lever (Inch)	B	43180	Belt Guard, Inner	P	56450	Index Tab	S
41176	Column Locking Lever (Metric)	B	43190	#2 x 1/4" Flat Head Sheet Metal Screw	S	56460	8-32 x 1/4" Button Head Screw	S
40177	Saddle Nut Assembly w/ Ball, Z-Axis (Inch)	B	43200	DC Speed Control Label	Foil	56470	3/32" x 1/2" Dowel Pin	S
40178	1/8" Ball	S	43230	Stepped Main Spindle Pulley	A	56550	#2000 Column Top	A
40179	Saddle Nut, Z-Axis, w/o Ball or Spring (Metric)	B	43360	Stepped Motor Pulley	A	56660	#2000 Column Base	A
40180	Tool Post	A	43450	DC Motor	--	56770	Column Spacer	A
40200	15" Leadscrew (LH) (Inch)	S	43460	DC Speed Control Electronics	--	67021	CNC Mill Column Bed	S
40220	Feed Screw (Tailstock spindle, LH) (Inch)	S	44010	24" Lathe Base	DC	67024	CNC 15" Leadscrew (LH) (Inch)	S
40230	Headstock Spindle	S	44120	24" Lathe Bed	S	67025	CNC 15" Leadscrew (LH) (Metric)	S
40240	Headstock Pivot Pin, Lathe	S	44200	24" Leadscrew (LH) (Inch)	S	67026	CNC 24" Leadscrew (LH) (Inch)	S
40250	Tool Post Tee Nut	S	44210	Slide Screw (Inch)	S	67027	CNC 24" Leadscrew (LH) (Metric)	S
40260	Head Key	S	44220	Slide Screw (Metric)	S	67028	CNC Z-axis Leadscrew (LH) (Inch)	S
40270	Tailstock Spindle (Inch)	S	44221	CNC Slide Screw (Inch)	S	67029	CNC Z-axis Leadscrew (LH) (Metric)	S
40280	Thrust Collar	S	44222	CNC Slide Screw (Metric)	S	67040	CNC Leadscrew Thrust (Lathe)	S
40300	Leadscrew Thrust	S	44230	24" Leadscrew (LH) (Metric)	S	67050	CNC Mill Table (No engraving)	A
40320	Bearing Washer	S	44880	Crossslide	A	67051	CNC Mill Table (Engraved Scales, Inch)	A
40330	10-32 x 5/8" Socket Head Cap Screw	S	45010	Leadscrew, Z-axis (LH) (Inch)	S	67052	CNC Mill Table (Engraved Scales, Metric)	A
40340	10-32 x 1" Socket Head Cap Screw	S	45030	Column Bed	S	67102	Stepper Motor Mount (all axes)	A
40370	Leadscrew Support (Metric 41370)	S	45040	Saddle, Z Axis	A	67105	CNC Coupling	S
40380	#1 Morse Center	S	45070	Lock, Teflon	P	67106	CNC Preload Nut, RH (Inch)	S
40390	#0 Morse Center	S	45160	Leadscrew, Z-axis (LH) (Metric)	S	67107	CNC Preload Nut, LH (Inch)	S
40400	Plug Button	P	45170	Column Saddle Lock	P	67108	CNC Preload Nut, RH (Metric)	S
40420	Headstock Bearing	Ball	45180	3/16" Ball Bearing	S	67109	CNC Preload Nut, LH (Metric)	S
40440	Self Tapping Screw	S	45190	#10 Type B Washer	S	67111	8-32 x 3/4" SHCS	S
40500	10-24 x 7/8" Socket Head Cap Screw	S	45200	Leadscrew Thrust, Bored	S	67115	5-40 x 7/8" SHCS	S
40501	10-32 x 1/2" Button Head Socket Screw	S	50010	10" Mill Base	A	67120	CNC Preload Bearing	Ball
40510	10-32 x 3/8" Socket Head Cap Screw	S	50050	Column Base	A	67150	CNC 10" Mill Base	A
40520	10-32 x 3/16" Cup Point Set Screw	S	50130	Backlash Nut, X-axis (Inch)	B	67151	CNC 12" Deluxe Mill Base (Inch)	A
40530	5-40 x 3/8" Socket Head Cap Screw	S	50140	Backlash Nut, Y-axis (Inch)	B	67152	CNC 12" Deluxe Mill Base (Metric)	A
40540	5/16-18 X 3/4" Cone Point Set Screw	S	50150	Anti-backlash Lock	B	90060	DC Speed Control 5K Potentiometer	--
40550	5/32" Hex Key	S	50160	Leadscrew, Y-axis (Inch)	S	90080	3/8-32 Hex Nut	S

MACHINING BASICS—USING THE HANDWHEELS

Precision leadscrews and the handwheels that drive them make it possible to produce highly accurate parts on a mill or lathe. Here are some tips that should help first-time machinists get off to a good start.

HANDWHEEL INCREMENTS

The handwheels on Sherline machines are marked in increments of one one-thousandth of an inch (.001") for inch models or one one-hundredth of a millimeter (.01 mm) for metric models. One turn of the handwheel causes the leadscrew to advance the tool or part .050" (inch models) and 1 mm (metric models). The leadscrews are precision rolled and are quite accurate. Therefore, moving the handwheel three rotations, for example, moves that axis exactly .150" (or .03mm on metric machines). This precise method of moving the tool or part is what makes it possible to make accurate parts on a metalworking lathe or mill.

When advancing the CROSSLIDE handwheel to take a cut on the lathe, keep in mind that the amount of metal removed is actually TWICE the amount you dial in. You are removing a given amount of material from the RADIUS of the part, which means you are actually removing twice that amount from the DIAMETER of the part. (Some lathes are set up with the crossslide feed reading the amount the diameter is reduced; however, since it is possible for Sherline lathes to also be used in a milling configuration where the crossslide feed becomes the X-axis feed for milling, this system was not used.)

TURNING THE HANDWHEELS

Each handwheel has a small handle. This is mainly used to advance the leadscrew quickly over long distances. When actually making a cut, or at least when making the final cut on a part, most machinists will turn the handwheel itself, using the outer surface and alternating back and forth between hands to

keep a smooth, continuous feed going. On small machines, the handwheel is turned by its outer knurled surface using the thumb and a finger of one hand. Then, as that hand is released, the thumb and finger of the other hand pick up the rotation. Using the handle on the handwheel can introduce pushing and pulling motions that can adversely affect the finish. (See Figure 83.)

FIGURE 83—A two-handed technique for turning the handwheels yields a better final finish on your part. Shown in use here is an adjustable "zero" handwheel.



ADJUSTABLE "ZERO" HANDWHEELS

Adjustable handwheels are optional on all Sherline machines and are standard on the deluxe models. The increments are marked on a collar which can be disengaged from the handwheel and reset to "zero" or any other desired setting. To release the collar, turn the black, knurled release knob on the outer face of the handwheel counterclockwise. The collar can then be adjusted without moving the handwheel itself. When reset to zero, carefully retighten the black locking knob to reengage the collar and then advance the handwheel. The advantage of this system is that it can eliminate errors when "dialing in" a dimension, as you are starting from zero each time, rather than adding one number to another to come up with the next stopping point.

TECHNICAL SPECIFICATIONS

LATHES	4000 (4100)	4400 (4410)	VERTICAL MILLS	5000 (5100)	5400 (5410)	2000 (2010)
Swing over bed	3.50" (90 mm)	3.50" (90 mm)	Max. clearance, table to spindle	8.00" (203 mm)	8.00" (203 mm)	9.00" (229 mm)
Swing over carriage	1.88" (48 mm)	1.88" (48 mm)	Throat (no spacer)	2.25" (50 mm)	2.25" (50 mm)	(Adjustable)
Distance between centers	8.00" (200 mm)	17.00" (430 mm)	(w/ headstock spacer)	3.50" (90 mm)	3.50" (90 mm)	(Adjustable)
Hole through spindle	.405" (10 mm)	.405" (10 mm)	Travel, X-axis	9.00" (228 mm)	9.00" (228 mm)	9.00" (228 mm)
Spindle nose ext. thread	3/4-16 T.P.I.	3/4-16 T.P.I.	Travel, Y-axis	3.00" (76 mm)	5.00" (127 mm)	7.00" (178 mm)
Spindle nose int. taper	#1 Morse	#1 Morse	Travel, Z-axis	6.25" (159 mm)	6.25" (159 mm)	5.38" (137 mm)
Travel of crossslide	4.25" (110 mm)	4.25" (110 mm)	Hole through spindle	.405" (10 mm)	.405" (10 mm)	.405" (10 mm)
Tailstock spindle taper	#0 Morse	#0 Morse	Spindle nose ext. thread	3/4-16 T.P.I.	3/4-16 T.P.I.	3/4-16 T.P.I.
Protractor graduations	0° to 45° by 5°	0° to 45° by 5°	Spindle nose int. taper	#1 Morse	#1 Morse	#1 Morse
Handwheel graduations	.001" (.01 mm)	.001" (.01 mm)	Handwheel graduations	.001" (.01 mm)	.001" (.01 mm)	.001" (.01 mm)
Electronically controlled spindle speed range	70 to 2800 RPM	70 to 2800 RPM	Electronically controlled Spindle speed range	70 to 2800 RPM	70 to 2800 RPM	70 to 2800 RPM
Length overall*	23" (584 mm)	32.5" (826 mm)	Width overall*	14.75" (375 mm)	15.00" (381 mm)	15.00" (381 mm)
Width overall*	10.25" (260 mm)	10.55" (267 mm)	Depth overall*	11.75" (298 mm)	14.00" (356 mm)	22.25" (565 mm)
Height overall*	8" (203 mm)	8.5" (216 mm)	Height overall (Max.)*	20.75" (527 mm)	20.75" (527 mm)	23.38" (568 mm)
Shipping weight	24 lb. (10.9 kg)	30 lb. (13.6 kg)	Table size	2.75" x 13.00" (70 mm x 330 mm)	2.75" x 13.00" (70 mm x 330 mm)	2.75" x 13.00" (70 mm x 330 mm)
			Hold-down provision	2 T-slots	2 T-slots	2 T-slots
			Shipping weight	33 lb (15.0 kg)	36 lb (16.3 kg)	38 lb (17.2 kg)
			Movements in addition to X-, Y- and Z-axes	Headstock rotation (90° L/R)	Headstock rotation (90° L/R)	Headstock rotation (90° L/R), Column rotation (90° L/R), Column pivot (90° Fwd/Bk), Column swing (90° L/R), Col. travel (In/Out) 5.5" (140 mm)

MOTOR SPECIFICATIONS

Input voltage—100 to 240 VAC, 50 to 60 Hz
 Output to motor—90 VDC
 Current draw—.5 to 15 amps depending on load
 No-load output shaft speed—6000 RPM (no pulley)

NOTE: Motor and speed control are available separately. Part numbers are as follows:

P/N 33050—DC Motor and Speed Control

P/N 33060—Headstock, DC Motor, Speed Control

*All overall dimensions include motor and speed control.

Sherline's owner, Joe Martin, has put together the ultimate book for the Sherline machinist...

This book gives you not just the "hows," but also the "whys" of machining

The perfect "next step" beyond this instruction book

Right now you are holding one of the most complete instruction booklets ever given away with any machine tool, regardless of size or price. However, as complete as it is, most new machinists will have more questions than can be answered in a basic instruction guide. The book, *Tabletop Machining*, gave Sherline's owner, Joe Martin, the chance to stretch out and expand these basic instructions to include much more detail on the machines and processes related to working with metal. Naturally, the book can not provide step-by-step instructions for your particular project, but rather it concentrates on the basics of metalworking. Armed with the right facts, tips and techniques, the machinist can then apply what is learned to his particular needs. Information is given on selecting materials; using a lathe and a mill; using measurement tools; coolants; sharpening cutting tools; using accessories for threading, indexing and gearcutting; setting up a home shop and much more. Plans and instructions for several simple projects are provided for beginning machinists.

Creative inspiration as well as instruction

A gallery of photos of superb miniature projects will show you what others have been able to produce using miniature

machine tools. Seeing these fine projects will set your mind to work in all sorts of new directions. A history of Sherline tools is also included. It is written from the point of view of giving you some guidance if you've ever thought of starting your own business or taking a product of your own to market.

Printing quality you'd expect in a book that chronicles the quest for perfection

This book will be equally at home on your living room coffee table or your shop workbench. Printed on 344 pages of high quality, glossy paper, this large 8.5" x 11" soft-bound book is packed with over 400 detail-rich color photos and hundreds of informative line drawings by longtime Sherline art director and technical illustrator, Craig Libuse. The "lay-flat" binding makes it easy to read and use as a reference in your shop. The 12-point cover is laminated with a plastic coating to protect it. Both the quality of the printing and the information within have

resulted in excellent reviews from customers and magazine editors alike. If you like tools and working on small, intricate projects, you should plan on adding this book to your library.

P/N 5301 (Softbound)—\$40.00

P/N 5302 (Hardbound, author signed)—\$60.00*

*NOTE: \$10.00 of purchase price is donated to the Joe Martin Foundation for Exceptional Craftsmanship.

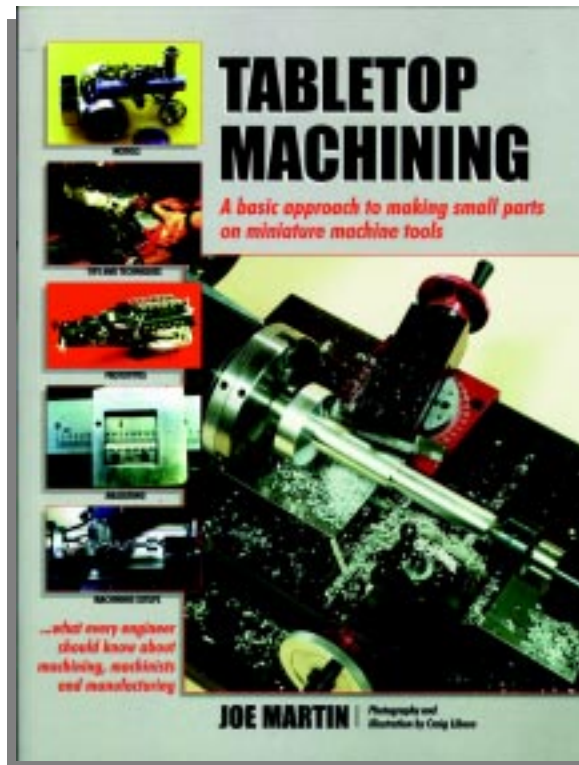

Enjoy the work of some of the world's
best craftsmen at

www.CraftsmanshipMuseum.com

SHERLINE PRODUCTS

INCORPORATED 1974

3235 Executive Ridge, Vista, CA 92083-8527

Phone Toll Free: 1-800-541-0735 • Local/International/Technical Assistance: 1-760-727-5857

Fax: (760) 727-7857 • Internet: www.sherline.com • E-mail: sherline@sherline.com

Order 24 hours a day on line at

www.SherlineDirect.com

PRINTED IN USA



SHERLINE PRODUCTS

INCORPORATED 1974

MINIATURE MACHINE TOOLS ASSEMBLY AND INSTRUCTION GUIDE



FIFTH EDITION