

Reference Schematics For RK3528

Title		
<Title>		
Size	Document Number	Rev
A4	<Doc>	<Rev C
Date:	Monday, November 13, 2023	Sheet 1 of 22

Generate Bill of Materials

Header:
Item\tPart\tDescription\tPCB Footprint\tReference\tQuantity\tOption

Combined property string:
{Item}\t{Value}\t{Description}\t{PCB Footprint}\t{Reference}\t{Quantity}\t{Option}

Notes

NOTE 1:
Component parameter description
1. DNP stands for component not mounted temporarily
2. If Value or option is DNP, which means the area is reserved without being mounted

NOTE 2:
Please use our recommended components to avoid too many changes.
For more informations about the second source,please refer to our AVL.

Description

Note

Option

RK3528_N (POWER)

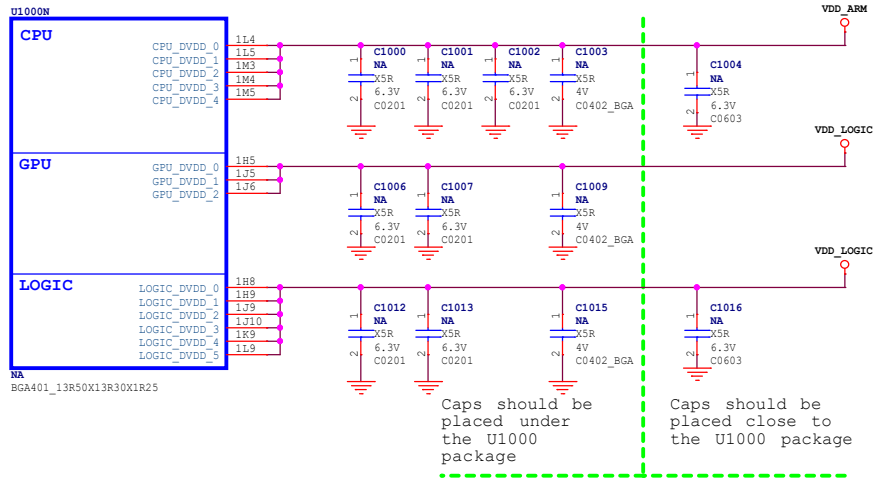

RK3528_O/P/Q (GND)

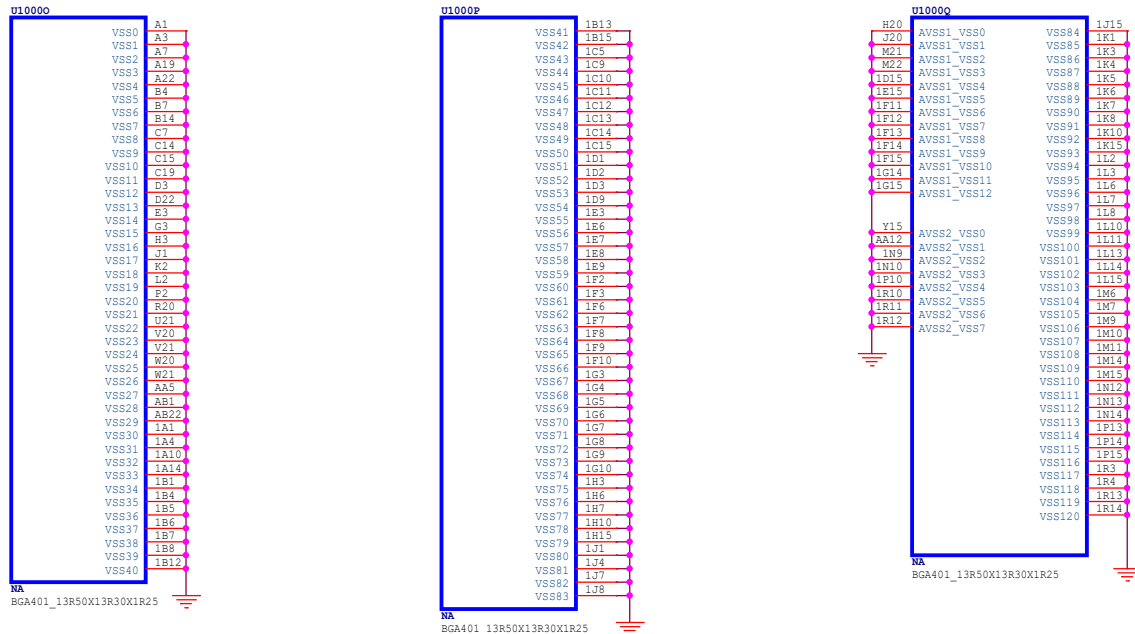

RK3528_B (OSC/PLL/PMUIO Domain)

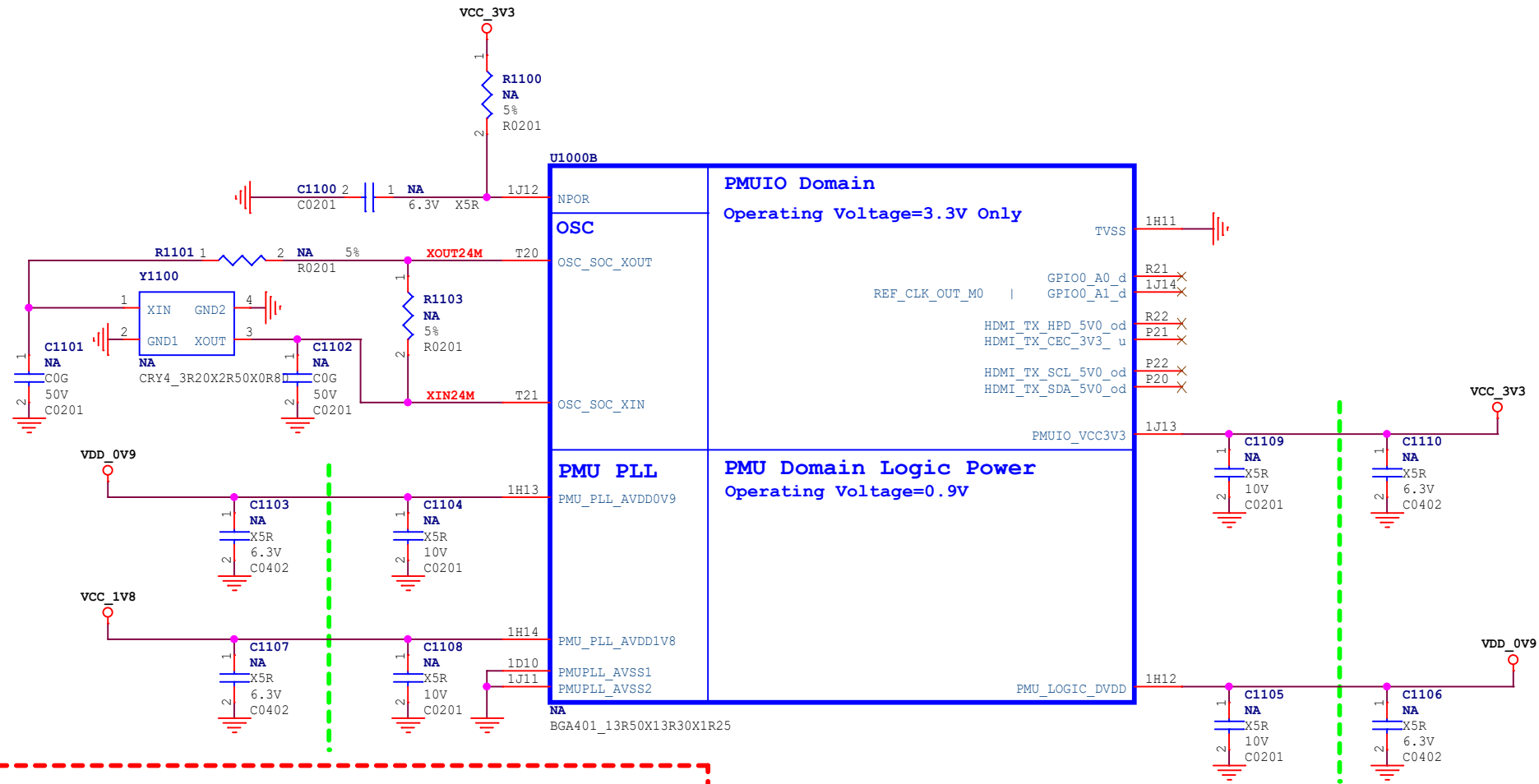

Title		
<Title>		
Size	Document Number	Rev
A4	<Doc>	<RevC>
Date:	Monday, November 13, 2023	Sheet 4 of 22

RK3528_E (VCCIO1 Domain)

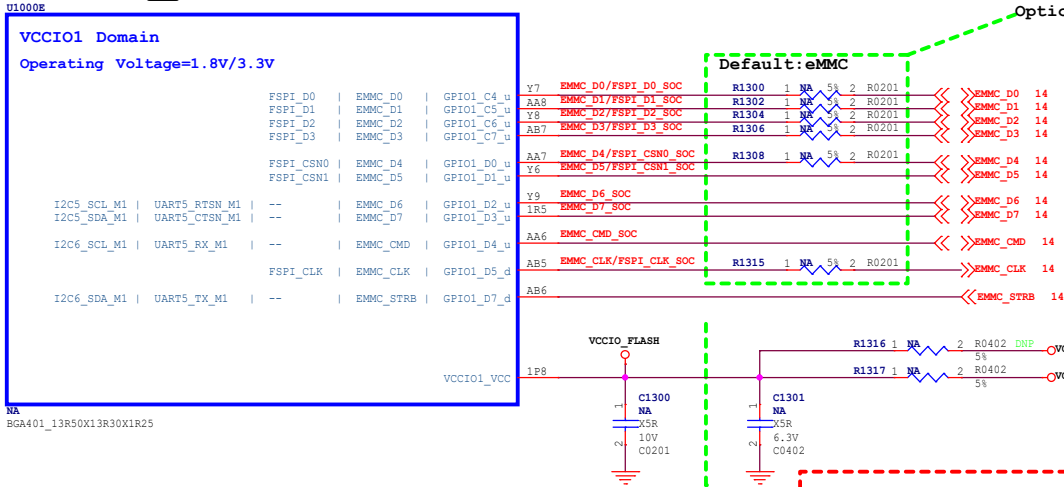

Option: SPI Flash

EMMC_D0/FSPI_D0_SOC	R1301	1	NA	5%	2	R0201	DNP	FSPI_D0	14
EMMC_D1/FSPI_D1_SOC	R1303	1	NA	5%	2	R0201	DNP	FSPI_D1	14
EMMC_D2/FSPI_D2_SOC	R1305	1	NA	5%	2	R0201	DNP	FSPI_D2	14
EMMC_D3/FSPI_D3_SOC	R1307	1	NA	5%	2	R0201	DNP	FSPI_D3	14
EMMC_D4/FSPI_CSNO_SOC	R1309	1	NA	5%	2	R0201	DNP	FSPI_CSNO	14
EMMC_CLK/FSPI_CLK_SOC	R1311	1	NA	5%	2	R0201	DNP	FSPI_CLK	14

FSPI (Flexible Serial Peripheral Interface) is only used to connect SPI Flash/Memory devices. Do not use for connecting to other SPI devices.

Default DiscretePower solution, power by VCC_1V8
 PMIC solution, power by VCC1V8_EMMC, only 1.8V

Note:
 Caps of between dashed green lines and U1000 should be placed under the U1000 package.
 Other caps should be placed close to the U1000 package

RK3528_F (VCCIO2 Domain)

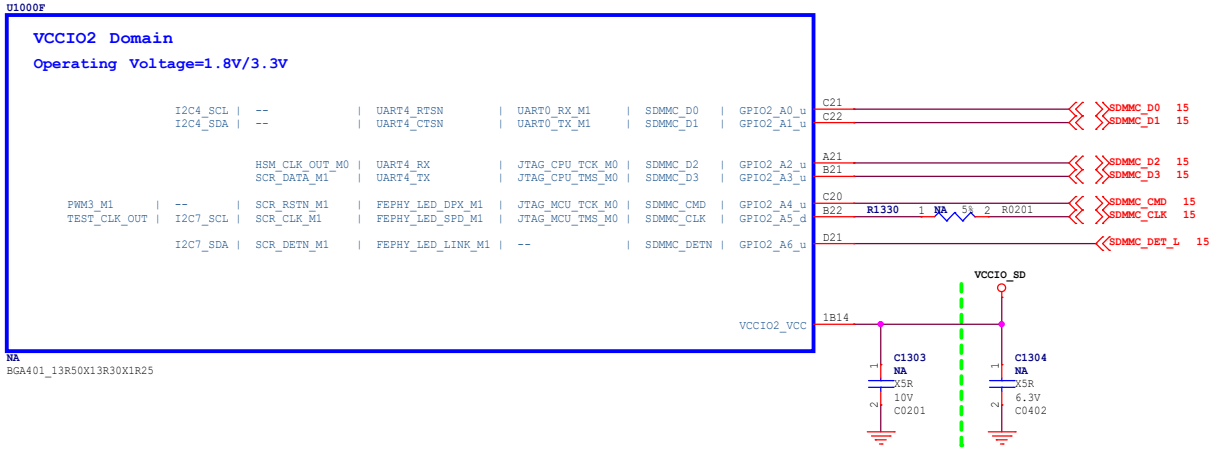

Note:
 Caps of between dashed green lines and U1000 should be placed under the U1000 package.
 Other caps should be placed close to the U1000 package

RK3528_I (USB2.0 OTG/HOST)

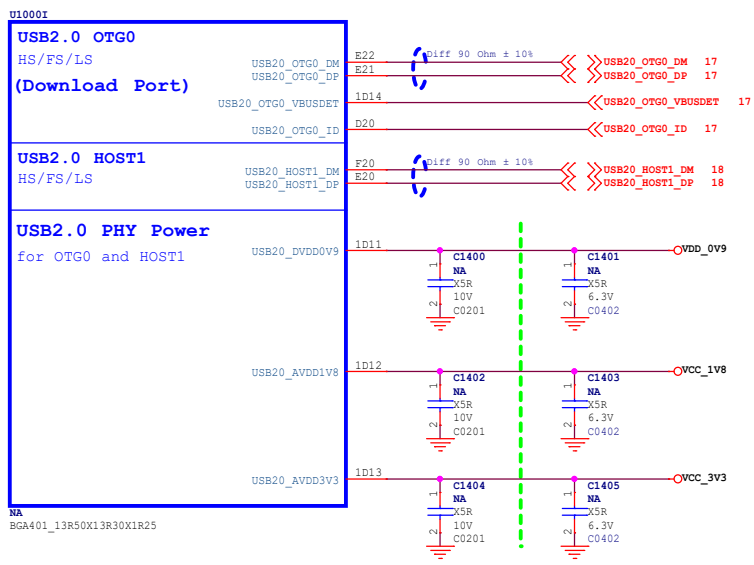

Note:
 Caps of between dashed green lines and U1000 should be placed under the U1000 package.
 Other caps should be placed close to the U1000 package

RK3528_J (PCIE2.0/U3 PHY)

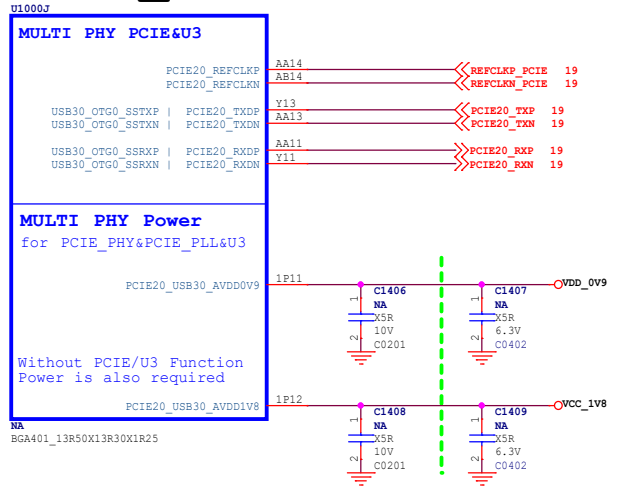

Note:
 Caps of between dashed green lines and U1000 should be placed under the U1000 package.
 Other caps should be placed close to the U1000 package

Title		<Title>
Size	Document Number	Rev
A3	<Doc>	<Rev Code>
Date:	Monday, November 13, 2023	Sheet 7 of 22

RK3528_C (Saradc/OTP)

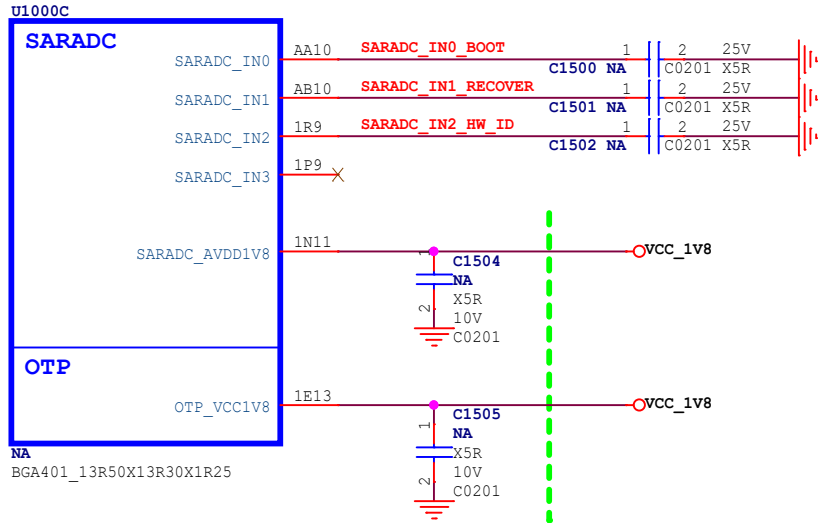

Note:

Caps of between dashed green lines and U1000 should be placed under the U1000 package. Other caps should be placed close to the U1000 package

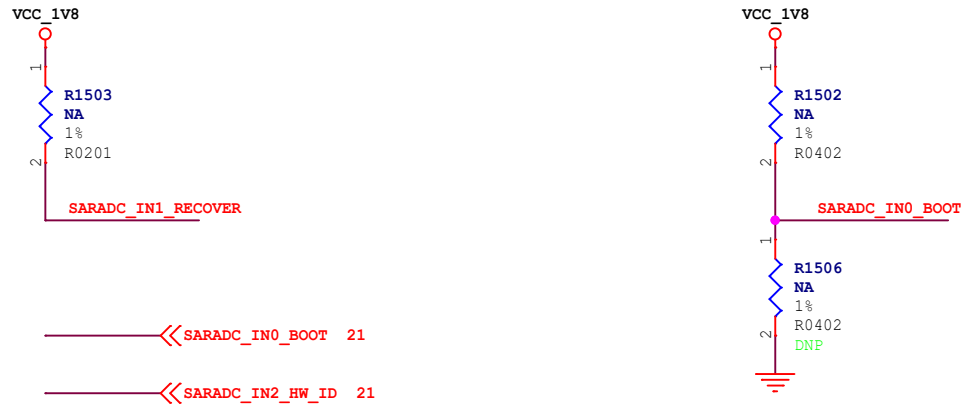

TABLE

Item	Rup	Rdown	ADC	BOOT MODE
LEVEL1	DNP	100K	0	USB (Maskrom mode)
LEVEL2	100K	12K	114	
LEVEL3	100K	27K	228	FSPI--USB
LEVEL4	100K	51K	342	
LEVEL5	100K	82K	456	
LEVEL6	100K	120K	570	EMMC--USB
LEVEL7	100K	200K	683	EMMC--SD Card--USB
LEVEL8	100K	330K	796	SD Card--USB
LEVEL9	100K	820K	910	
LEVEL10	100K	DNP	1023	FSPI--EMMC--SD Card--USB

Title		
<Title>		
Size	Document Number	Rev
A4	<Doc>	<RevC>
Date:	Monday, November 13, 2023	Sheet 8 of 22

RK3528_L (HDMI PHY)

U1000L

HDMI2.1 TMDS

HDMI_TX_CLKN N21
HDMI_TX_CLKP N20
HDMI_TX_D0N M20
HDMI_TX_D0P L20
HDMI_TX_D1N K20
HDMI_TX_D1P K21
HDMI_TX_D2N J21
HDMI_TX_D2P J22

HDMI_REXT

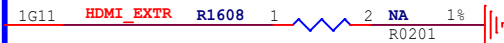

HDMI PHY Power

HDMI_TX_DVDD0V9

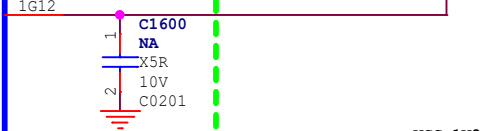

HDMI_TX_AVDD1V8

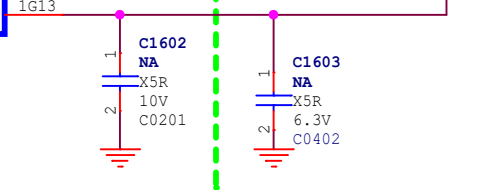

NA
BGA401_13R50X13R30X1R25

Note:

Caps of between dashed green lines and U1000 should be placed under the U1000 package.
Other caps should be placed close to the U1000 package

Title		
<Title>		
Size	Document Number	Rev
A4	<Doc>	<RevC
Date:	Monday, November 13, 2023	Sheet 9 of 22

RK3528_M (Acodec/VDAC)

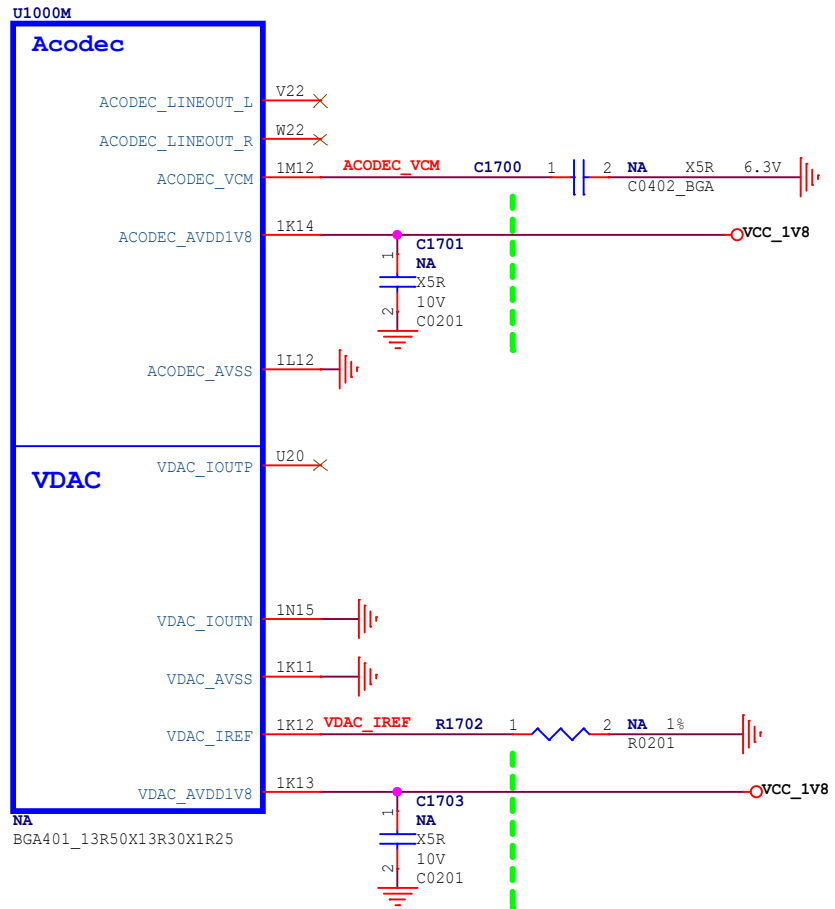

Note:
Caps of between dashed green lines and U1000 should be placed under the U1000 package.
Other caps should be placed close to the U1000 package

Title		
<Title>		
Size	Document Number	Rev
A4	<Doc>	<RevC>
Date:	Monday, November 13, 2023	Sheet 10 of 22

RK3528_K (Embed FEPHY)

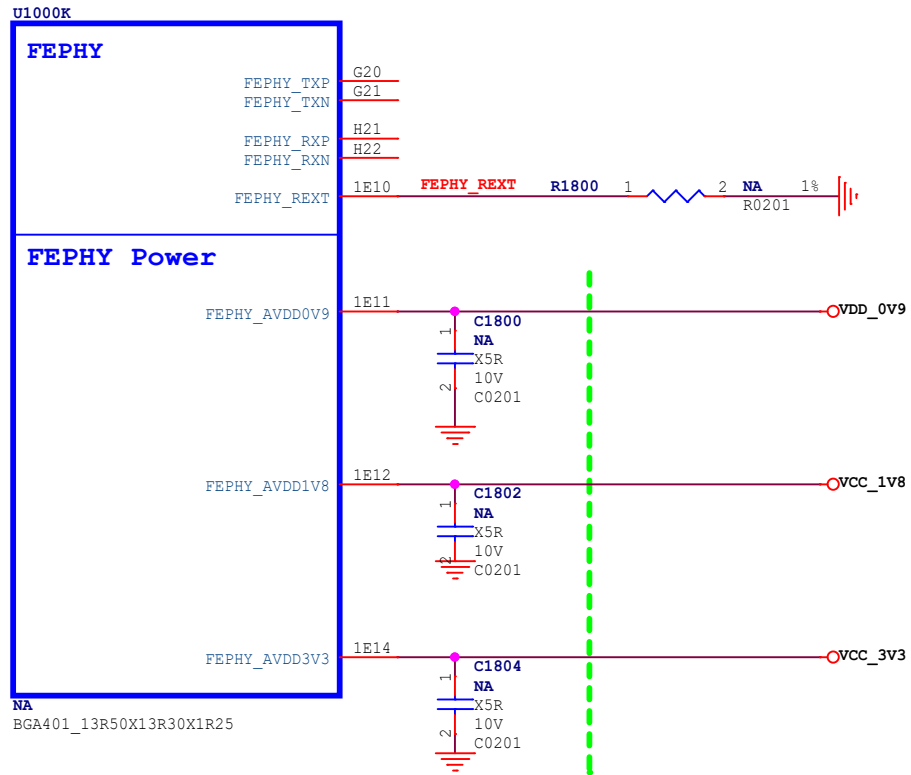

Note:

Caps of between dashed green lines and U1000 should be placed under the U1000 package.
Other caps should be placed close to the U1000 package

Title		
<Title>		
Size	Document Number	Rev
A4	<Doc>	<RevC>
Date:	Monday, November 13, 2023	Sheet 11 of 22

RK3528_D (VCCIO0 Domain)

U10000

VCCIO0 Domain
Operating Voltage=1.8V/3.3V

PMN0_M1	I2C3_SCL_M0	SCR_DATA_M0	PCIE_CLKREQ_M1	SDIO0_D0	GPIO1_A0_d	A82
	I2C3_SDA_M0	SCR_DATA_M0	PCIE_WAKEN_M1	SDIO0_D1	GPIO1_A1_d	Y3
PMN1_M1	UART7_RX_M0	SCR_CLK_M0	PCIE_FERSTN_M1	SDIO0_D2	GPIO1_A2_d	Y4
PMN1_M1	UART7_TX_M0	SCR_RSTN_M0	--	SDIO0_D3	GPIO1_A3_d	Y81
PMN2_M1	--	HSM_CLK_OUT_M1	--	SDIO0_CMD	GPIO1_A4_d	A83
	UART7_RTN_M0	I2C3_SCL_M1	--	SDIO0_CLK	GPIO1_A5_d	A83
	UART7_CTSN_M0	I2C3_SDA_M1	--	SDIO0_DETN	GPIO1_A6_d	A82
PMN2_M1	--	--	--	SDIO0_PWREN	GPIO1_A7_d	Y87
UART7_CTSN_M1	--	--	UART6_RX_M1	GPIO1_B0_d	Y87	
UART7_RTN_M1	--	--	UART7_TX_M1	GPIO1_B1_d	Y86	
UART7_TX_M1	--	--	UART7_RTSN_M1	GPIO1_B2_d	Y86	
UART7_RX_M1	I2C5_SCL_M0	--	UART7_CTSN_M1	GPIO1_B3_d	Y86	
UART7_RX_M1	I2C5_SDA_M0	--	--	GPIO1_B4_d	Y85	
				GPIO1_B5_d	Y88	
				GPIO1_B6_d	Y88	
				GPIO1_B7_d	Y88	
				GPIO1_C0_d	Y88	
				GPIO1_C1_d	Y87	
PMN7_M1	--	--	SP11_CSN1	GPIO1_C2_d	Y84	
PMN6_M1	--	SP01F_TX_M1	--	CLK_32K_OUT_M1	GPIO1_C3_d	Y5

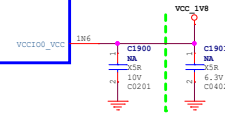

Note:
Caps of between dashed green lines and U1000 should be placed under the U1000 package.
Other caps should be placed close to the U1000 package

RK3528_G (VCCIO3 Domain)

U10000

VCCIO3 Domain
Operating Voltage=1.8V/3.3V

	TS10_D7	UART2_RX_M0	RGM11_TXD1	GPIO3_A0_d	A819
	TS10_D6	UART2_TX_M0	RGM11_TXD0	GPIO3_A1_d	Y18
	TS10_D5	UART2_RTSN_M0	RGM11_RXD0	GPIO3_A2_d	Y17
	TS10_D4	UART2_CTSN_M0	RGM11_RXD0	GPIO3_A3_d	A818
	UART6_CTSN	--	TS11_D0	GPIO3_A4_d	Y20
	UART6_RTSN	--	TS11_CLKIN	GPIO3_A5_d	A822
	PCIE_CLKREQ_M0	--	TS11_VALID	GPIO3_A6_d	A821
	PCIE_WAKEN_M0	--	TS11_SYNC	GPIO3_A7_d	A820
PCIE_FERSTN_M0	--	UART7_CTSN_M0	TS10_D1	GPIO3_B0_d	Y19
	--	UART7_RTSN_M0	TS10_D2	GPIO3_B1_d	Y20
	--	UART7_TX_M0	TS10_D3	GPIO3_B2_d	Y21
	--	UART7_RX_M0	TS10_CLKIN	GPIO3_B3_d	Y21
	--	I2C6_SCL_M0	TS10_VALID	GPIO3_B4_d	Y16
	--	I2C6_SDA_M0	SDIO1_DETN	GPIO3_B5_d	Y16
			TS10_SYNC	GPIO3_B6_d	Y16
			TS10_D1	GPIO3_B6_d	A817
			TS10_D2	GPIO3_B6_d	A817
			TS10_D3	GPIO3_B7_d	A816
			TS10_FAIL	GPIO3_C0_d	A815
PMN6_M2	--	UART6_TX_M1	I2C3_SCL_M1	GPIO3_C1_d	A819
PMN5_M1	SP01F_TX_M2	UART6_RX_M1	I2C3_SDA_M1	GPIO3_C2_d	Y20
		REF_CLK_OUT_M1	CLK_32K_OUT_M0	GPIO3_C3_d	Y20

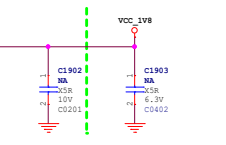

Note:
Caps of between dashed green lines and U1000 should be placed under the U1000 package.
Other caps should be placed close to the U1000 package

RK3528_H (VCCIO4 Domain)

U10000

VCCIO4 Domain
Operating Voltage=1.8V/3.3V

PMN1_DEBOG	--	I2C0_SDA_M1	--	SP01F_TX_M0	--	GPIO4_A0_d	X3
		I2C0_SCL_M1	--	SOMMIO_PWREN	--	GPIO4_A1_d	X1
I2C1_SDA_M0	--	UART3_RTSN	--	--	I2S1_SD13	GPIO4_A2_d	Y2
I2C1_SCL_M0	--	UART3_CTSN	--	--	I2S1_SD12	GPIO4_A3_d	Y2
UART1_CTSN	--	--	--	PWM_CLK1	I2S1_MCLK	GPIO4_A4_d	Y20
UART1_RTSN	--	--	--	--	I2S1_SCLK	GPIO4_A5_d	Y20
UART1_TX_M0	--	--	--	--	I2S1_LCLK	GPIO4_A6_d	Y20
UART1_RX_M0	--	--	--	--	I2S1_SDO0	GPIO4_A7_d	Y23
		UART3_RX_M0	--	--	I2S1_SD01	GPIO4_B0_d	Y22
		UART3_TX_M0	--	--	I2S1_SD02	GPIO4_B1_d	Y22
		SP10_MOS1	PWM_SD10	I2S1_SD03	GPIO4_B2_d	Y23	
		SP10_MISO	PWM_SD12	I2S1_SD11	GPIO4_B3_d	Y23	
		SP10_CLK	--	I2S1_SD10	GPIO4_B4_d	Y22	
		SP10_CSND	--	--	GPIO4_B5_d	Y23	
				PWM_CTR1L	GPIO4_B6_d	Y23	
PMN4_M0	--	FEFHY_LED_SPD_M0	UART3_RX_M1	--	--	GPIO4_B7_d	Y22
PMN5_M0	--	FEFHY_LED_LINX_M0	UART3_TX_M1	--	--	GPIO4_C0_d	Y22
PMN6_M0	--	--	--	SP10_CSN1	PWM_SD13	GPIO4_C1_d	Y22
PMN7_M0	--	--	--	--	PWM_CTR1G	GPIO4_C2_d	Y22
PMN0_M0	--	--	--	GPU_AVS	--	GPIO4_C3_d	Y21
PMN0_M0	--	--	--	ARM_AVS	--	GPIO4_C4_d	Y22
PMN2_M0	--	UART3_TX_M1	--	--	I2C0_SCL_M1	GPIO4_C5_d	Y21
PMN3_M0	--	UART3_RX_M1	--	--	I2C1_SCL_M1	GPIO4_C6_d	Y21
					I2C1_SDA_M1	GPIO4_C7_d	Y22
UART0_RX_M0	JTAG_MCU_TMS_M1	JTAG_CPU_TMS_M1	--	GPIO4_C7_d	Y22		
UART0_TX_M0	JTAG_MCU_TCK_M1	JTAG_CPU_TCK_M1	--	GPIO4_D0_d	Y22		

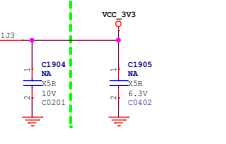

Note:
Caps of between dashed green lines and U1000 should be placed under the U1000 package.
Other caps should be placed close to the U1000 package

LPDDR4X 200Ball

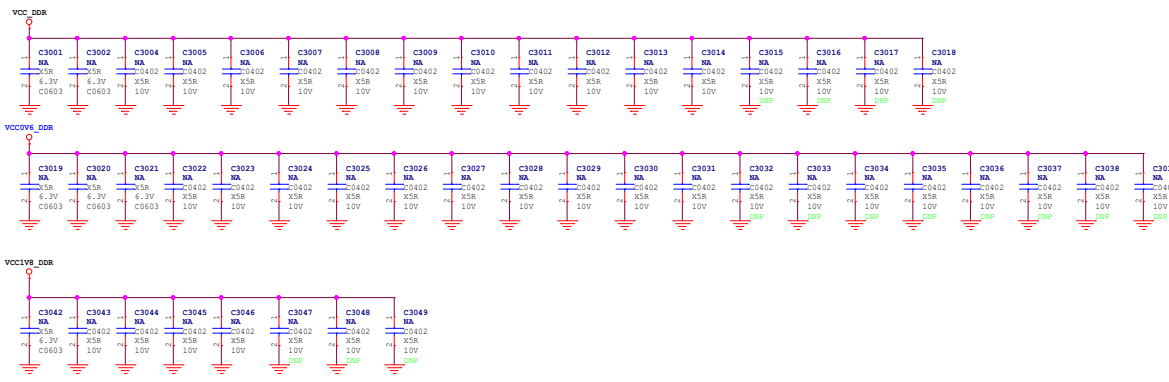
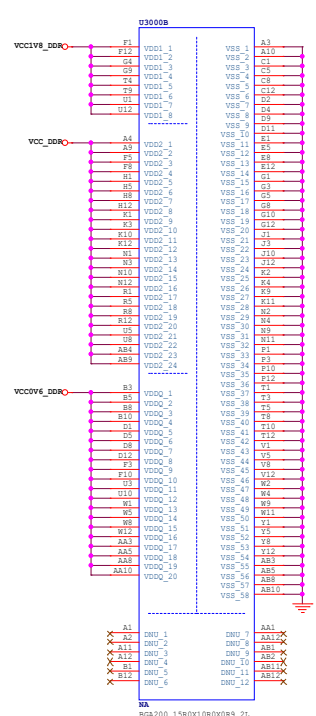
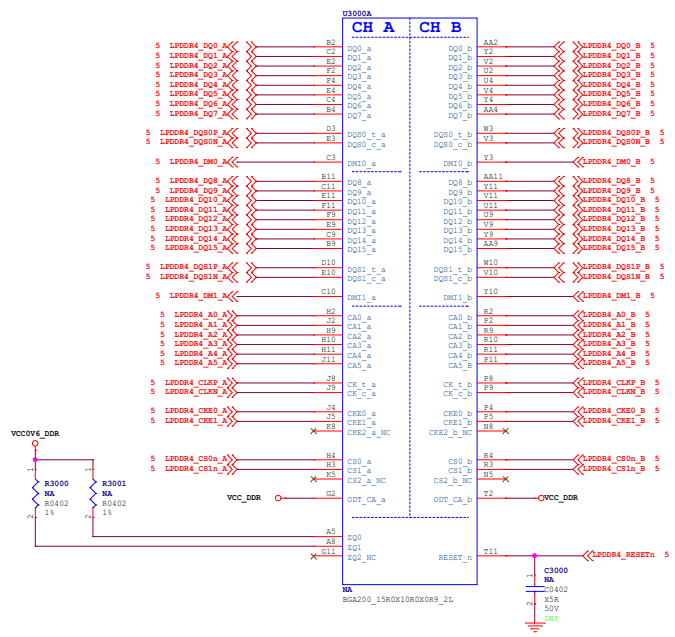

VCC0V6_DDR

VCC1V8_DDR

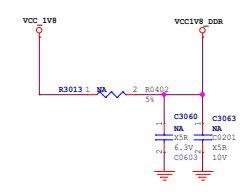
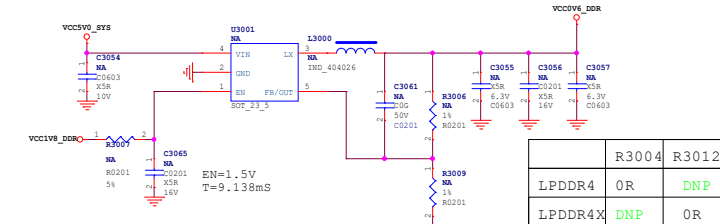

EMMC

FSPI

Default VCC = 1.8V

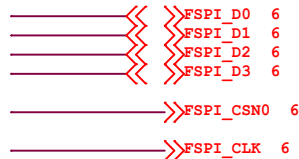
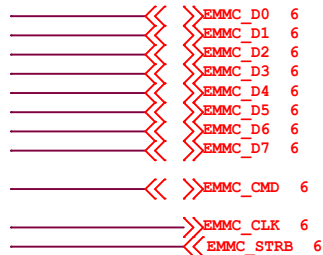

U4000B		NA	
A2	NC2	RFU1	NC196
A8	NC8	RFU2	NC195
A9	NC9	RFU3	NC194
A10	NC10	RFU4	NC193
A11	NC11	G3	NC191
A12	NC12	G10	NC190
A13	NC13	K6	NC184
A14	NC14	K7	NC183
		RFU5	
B1	NC15	RFU6	NC182
B7	NC21	RFU7	NC181
B8	NC22	RFU8	NC180
B9	NC23	RFU9	NC179
B10	NC24	P7	NC178
B11	NC25	P10	NC177
B12	NC26		NC175
B13	NC27		NC174
B14	NC28		NC171
			NC169
C1	NC29		
C3	NC31		NC168
			NC167
C7	NC35		NC166
C8	NC36		NC165
C9	NC37		NC164
C10	NC38		NC163
C11	NC39		NC162
C12	NC40		NC161
C13	NC41		NC157
C14	NC42		NC156
			NC155
D1	NC43		
D2	NC44		
D3	NC45		NC154
D4	NC46		NC153
D12	NC54		NC152
D13	NC55		NC143
D14	NC56		NC142
			NC141
E1	NC57		
E2	NC58		NC140
E3	NC59		NC139
E12	NC68		NC138
E13	NC69		NC129
E14	NC70		NC128
			NC127
F1	NC71		
F2	NC72		
F3	NC73		J14
F12	NC82		NC126
F13	NC83		NC125
F14	NC84		NC124
			NC115
			NC114
G1	NC85		NC113
G2	NC86		
G12	NC96		NC112
G13	NC97		NC111
G14	NC98		NC110
			NC101
			NC100
			H1

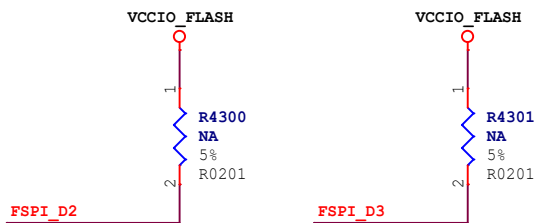
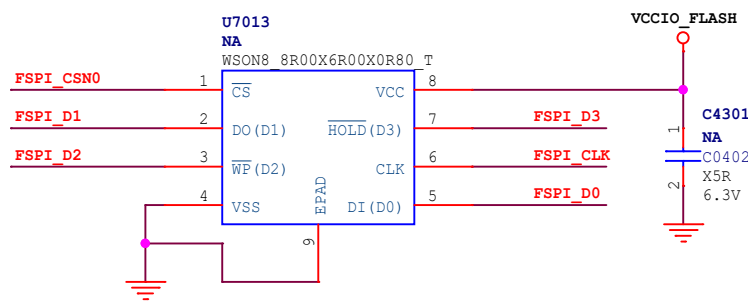
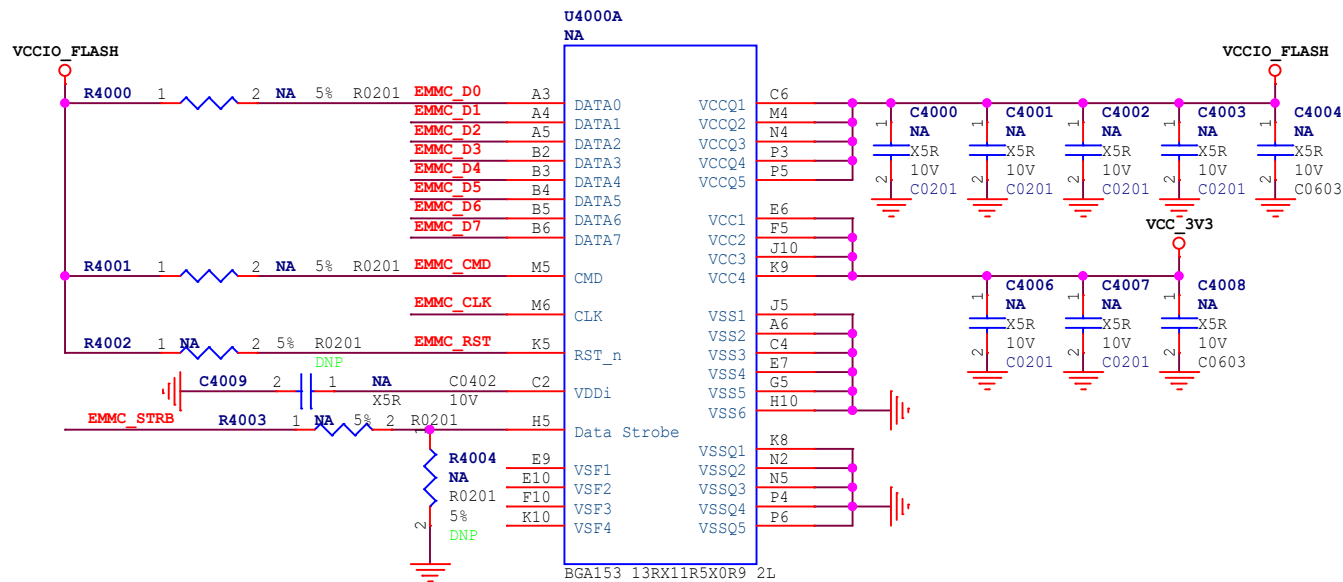

Title			<Title>
Size	Document Number		Rev
A4	<Doc>		<RevC>
Date:	Monday, November 13, 2023	Sheet	14 of 22

TF Card

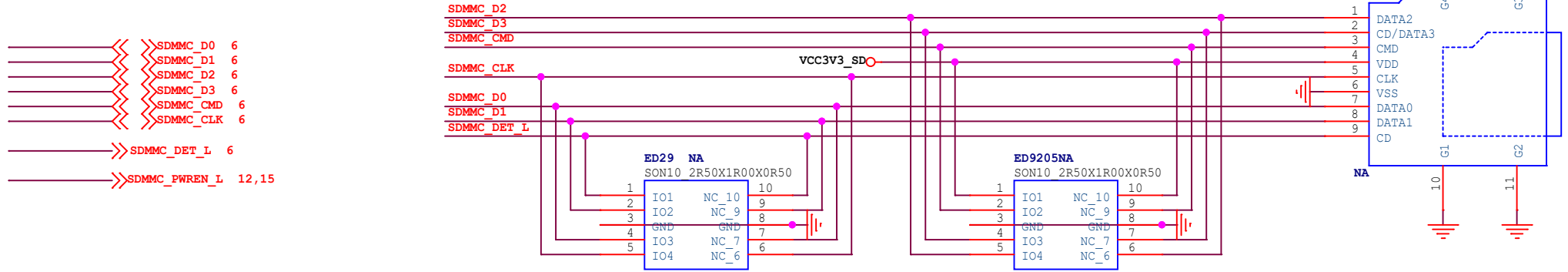

VCCIO_SD

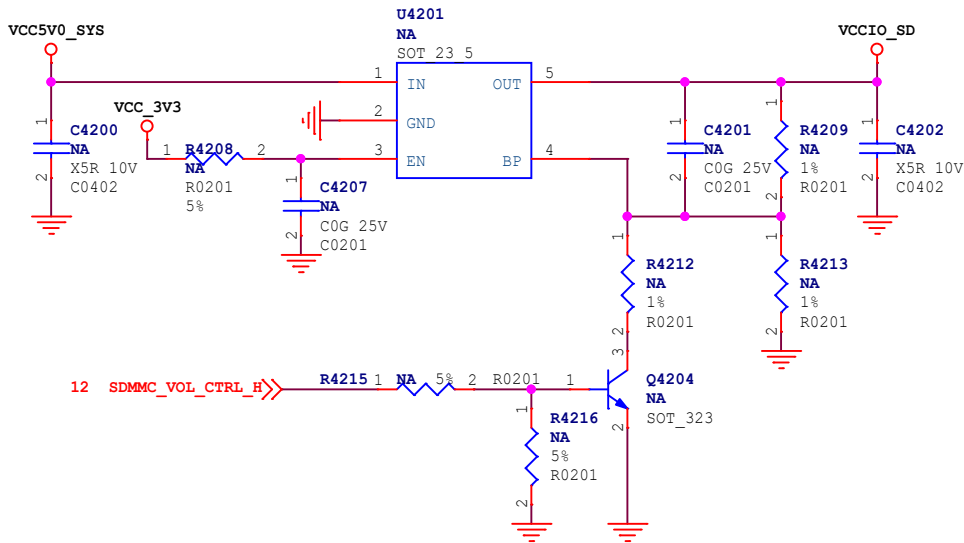

VCC3V3_SD

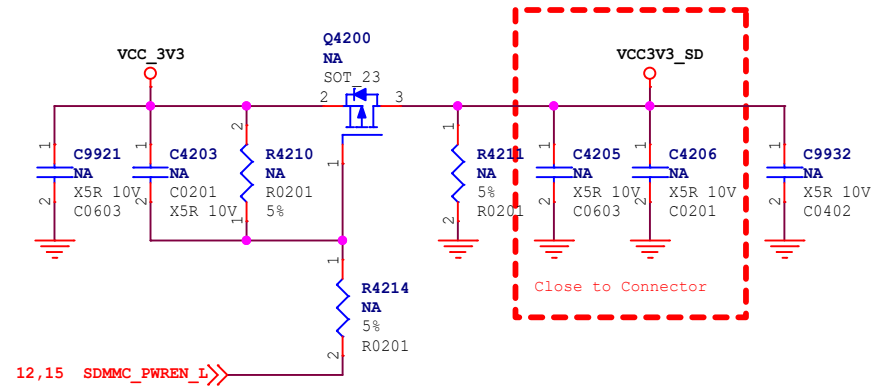

SDMMC_PWREN=L VCC_SD=3.3V(Default)
SDMMC_PWREN=H VCC_SD=0V

SDIO2.0 SDMMC0_VOL_CTRL=H VCCIO_SD=3.34V(Default)
SDIO3.0 SDMMC0_VOL_CTRL=L VCCIO_SD=1.816V

Title			<Title>
Size	Document Number		Rev
A4	<Doc>		<RevC>
Date:	Monday, November 13, 2023	Sheet	15 of 22

VCC5V0_SYS-->VDD_LOGIC

Step 1

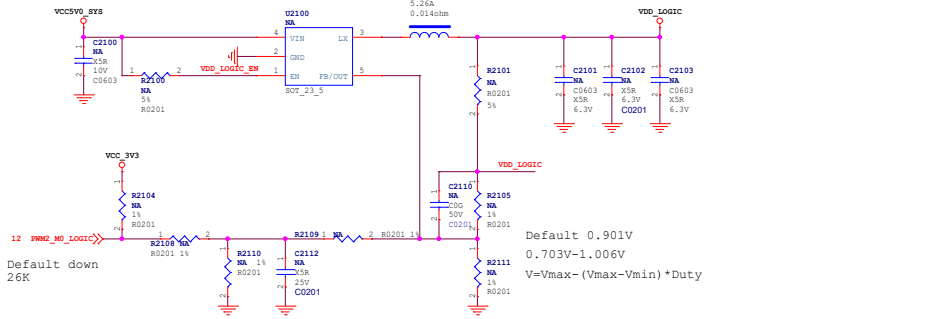

VCC5V0_SYS-->VDD_ARM

Step 1

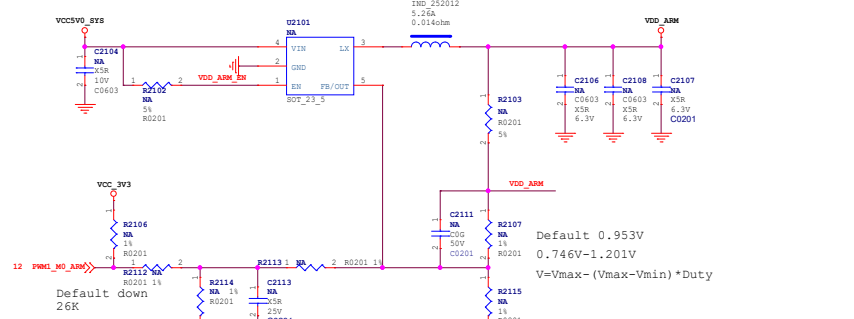

VCC5V0_SYS-->VDD_0V9

Step 1

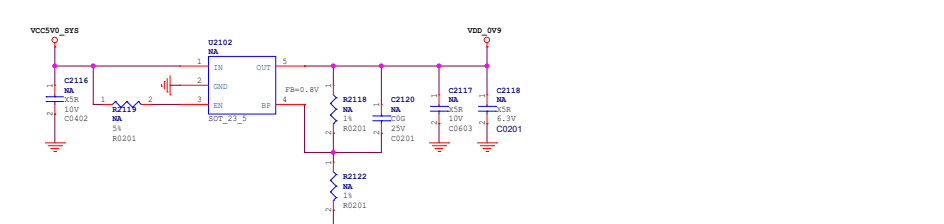

Note:
When LAYOUT, a star must be used,
Branch to each load

VCC5V0_SYS-->VCC_DDR

Step 2

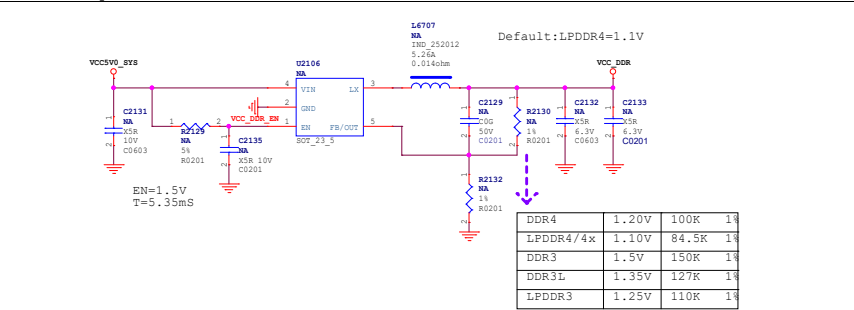

VCC_3V3->VCC_1V8(LDO)

Step 2

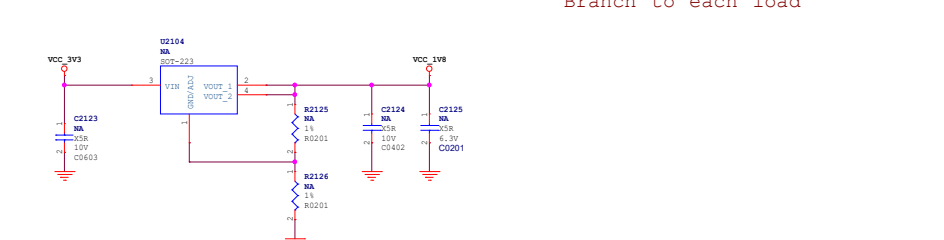

Note:
When LAYOUT, a star must be used,
Branch to each load

VCC5V0_SYS-->VCC_3V3

Step 2

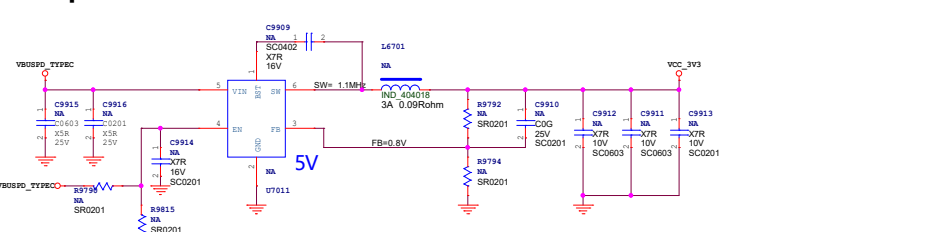

5V_SYS

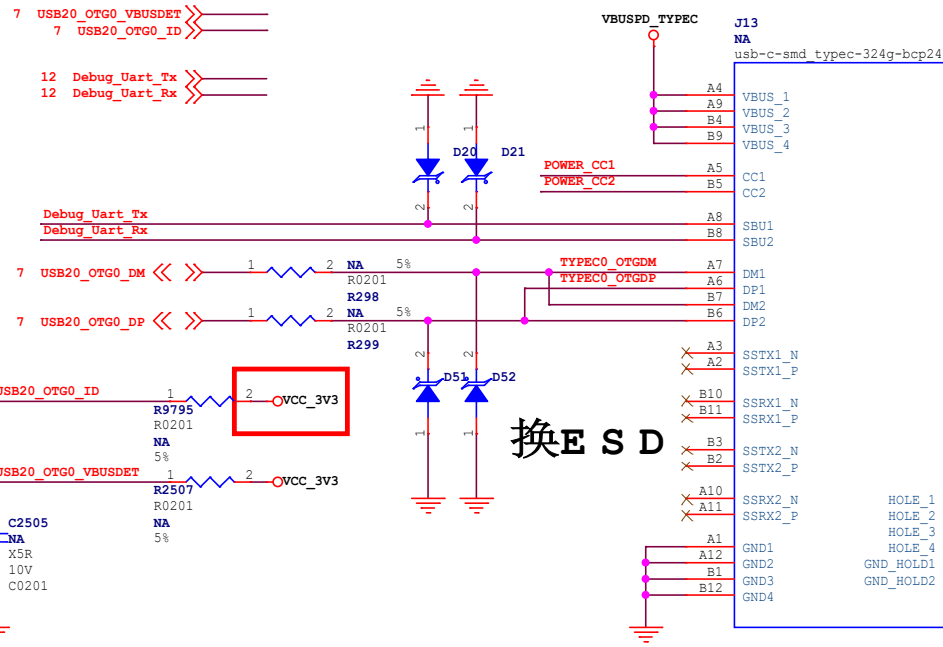
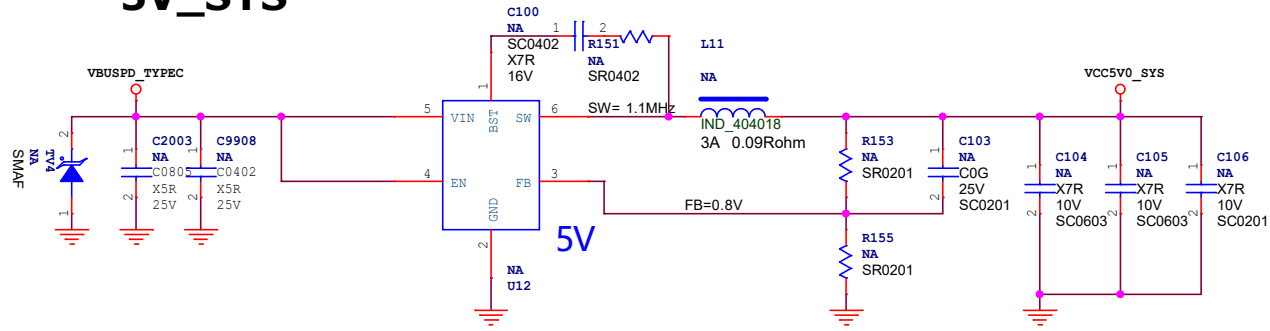

OTG USB+Debug

换ESD

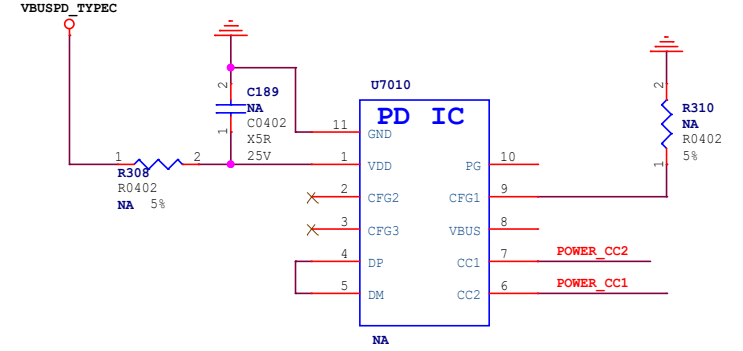

Title		
<Title>		
Size	Document Number	Rev
Custom	<Doc>	<RevCode>
Date:	Monday, November 13, 2023	Sheet 17 of 22

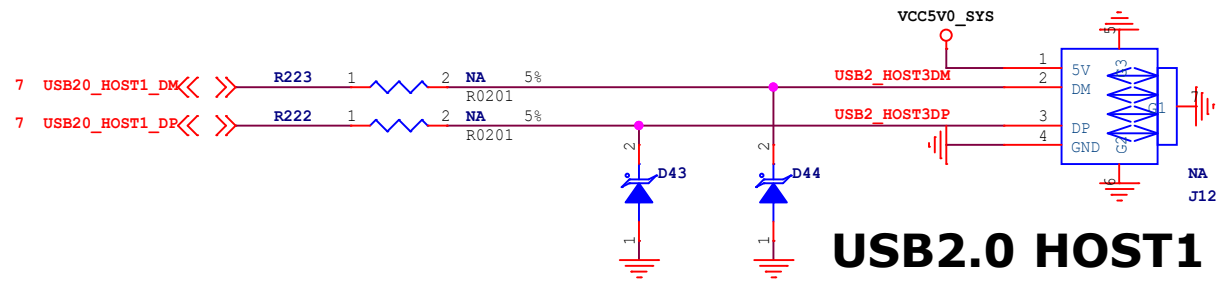

USB2.0 HOST1

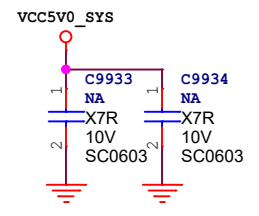

Title		
<Title>		
Size	Document Number	Rev
A4	<Doc>	<RevC>
Date:	Monday, November 13, 2023	Sheet 18 of 22

PCIe TO RJ45

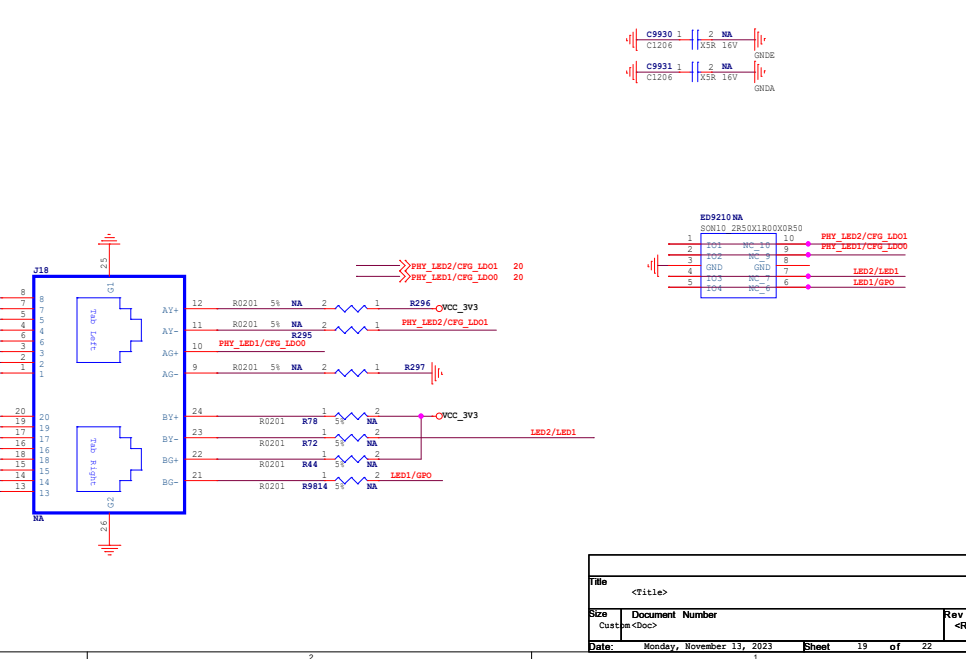
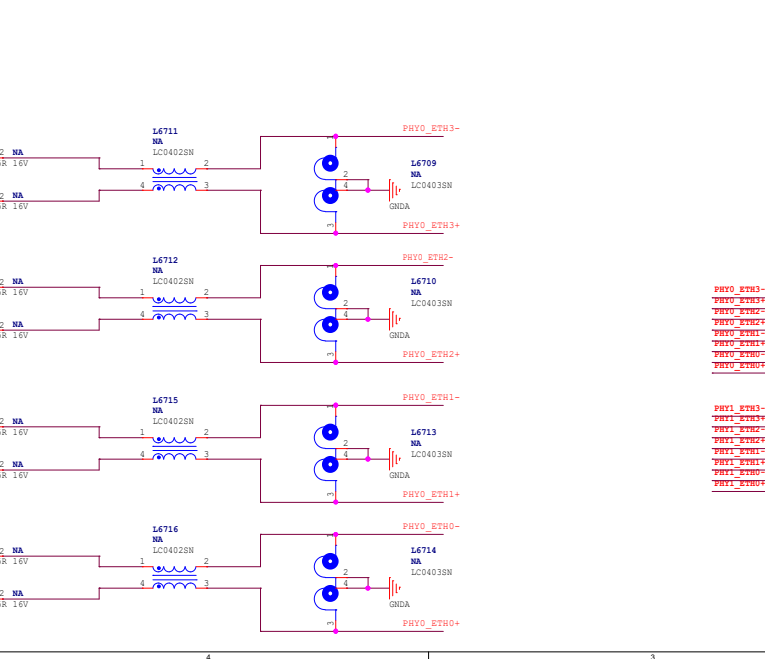
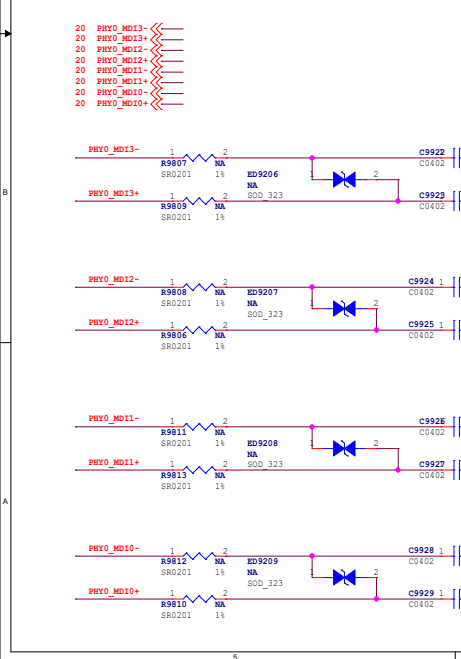
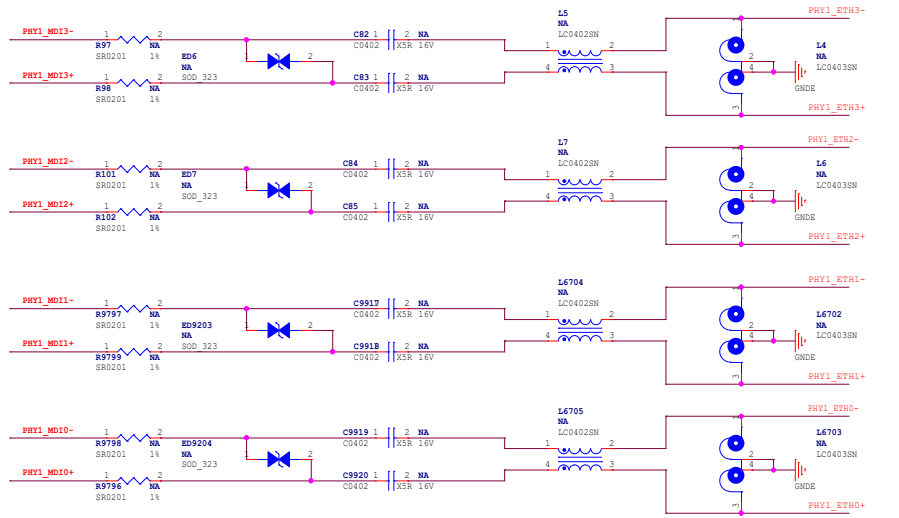
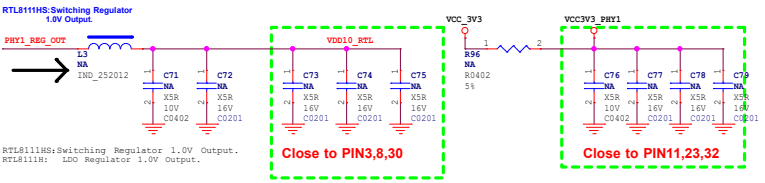
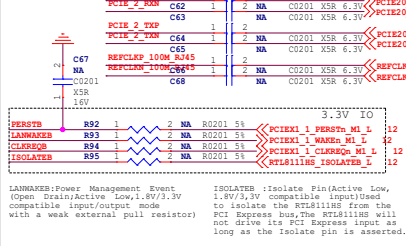
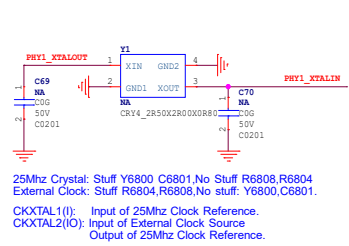
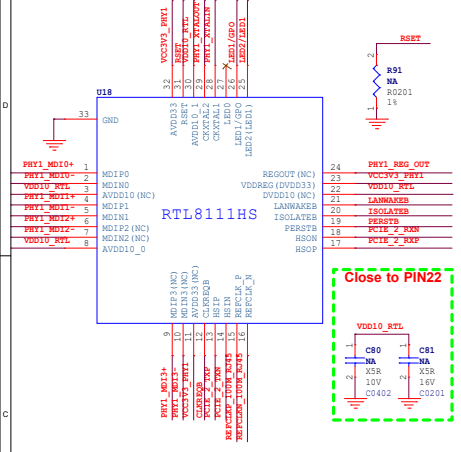

File	<Title>	Rev
Size	Document Number	19 of 22
Custom Doc		
Date:	Monday, November 13, 2023	Sheet

RGMI I

- >>GMAC1_TXD0 12
- >>GMAC1_TXD1 12
- >>GMAC1_TXD2 12
- >>GMAC1_TXD3 12
- >>GMAC1_TXEN 12
- <<GMAC1_RXCLK 12
- <<GMAC1_RXD0 12
- <<GMAC1_RXD1 12
- <<GMAC1_RXD2 12
- <<GMAC1_RXD3 12
- <<GMAC1_RXDV_CRS 12
- <<GMAC1_RXCLK 12
- >>GMAC1_MCLKINOUT 12
- >>GMAC1_MDC 12
- >>GMAC1_MDIO 12
- >>GMAC1_RSTn_L 12

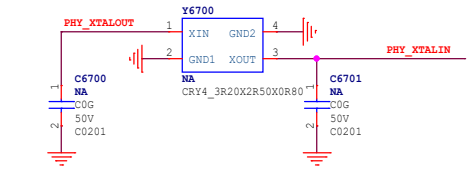

- >>PHY0_MD13- 20
- >>PHY0_MD13+ 20
- >>PHY0_MD12- 20
- >>PHY0_MD12+ 20
- >>PHY0_MD11- 20
- >>PHY0_MD11+ 20
- >>PHY0_MD10- 20
- >>PHY0_MD10+ 20
- >>PHY_LED2/CFG_LD01 19
- >>PHY_LED1/CFG_LD00 19

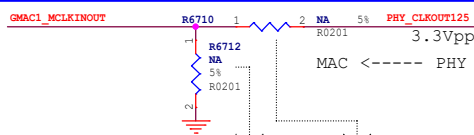

VCCIO_PHY0=3.3V	DNP	22R	Default
VCCIO_PHY0=1.8V	120R	100R	

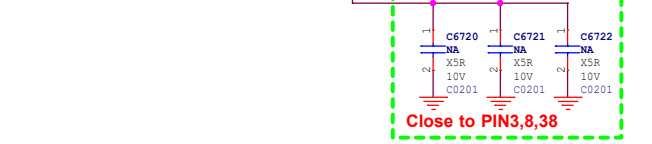
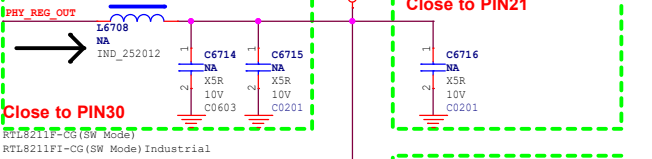
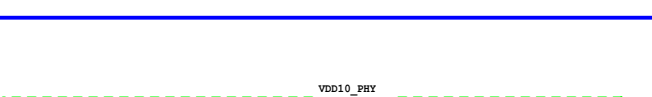
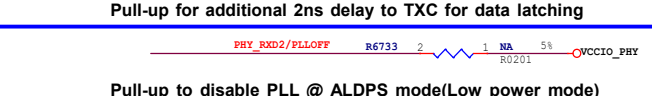
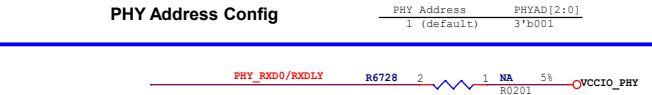
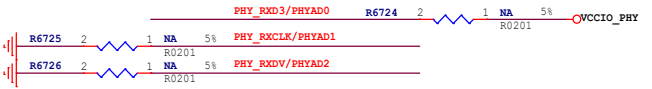
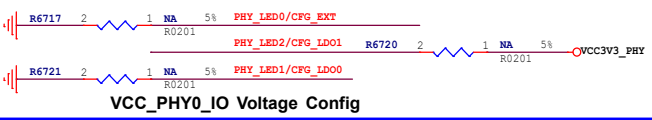
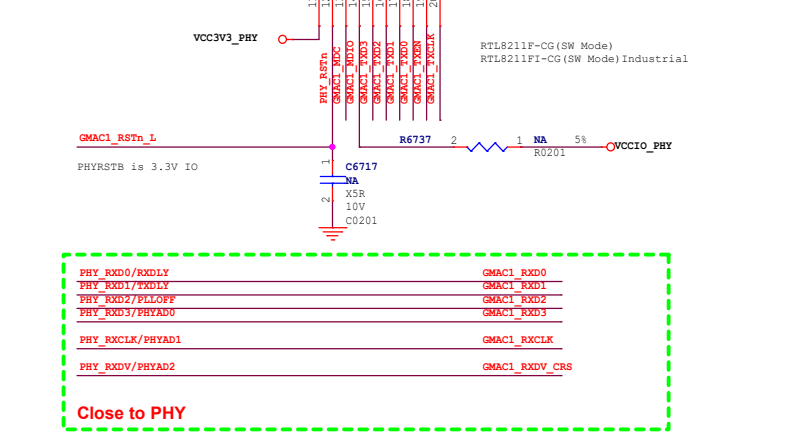
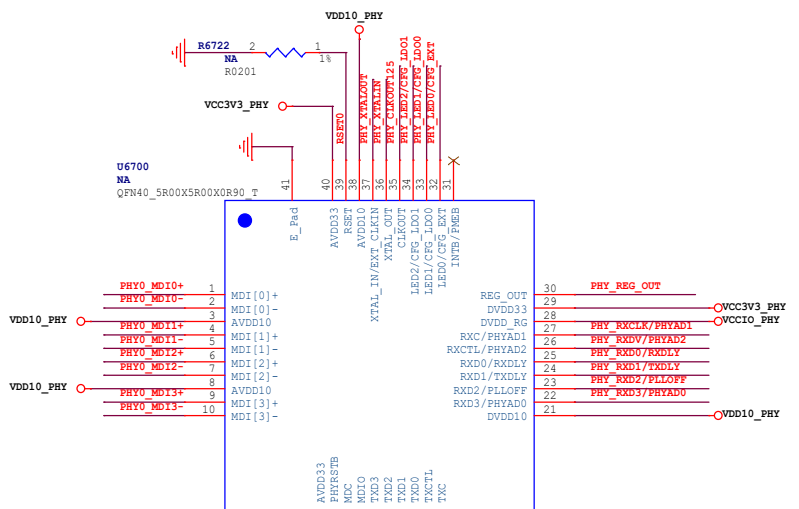

RGMI I Power Source	CFG_EXT	CFG_LD0[1:0]
External 3.3V	1'b1	2'b00
External 1.8V	1'b1	2'b10
Internal 1.8V(default)	1'b0	2'b10

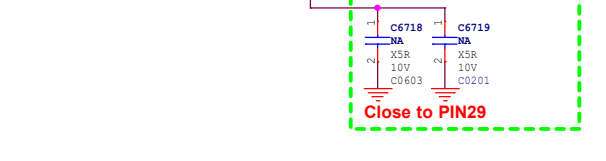
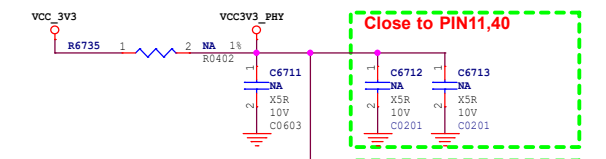
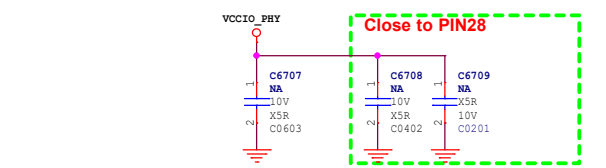

Title	<Title>
Size	A3
Document Number	<Doc>
Date:	Monday, November 13, 2023
Sheet	20 of 22

KEY

← SARADC_IN0_BOOT 8

← SARADC_IN2_HW_ID 8

SARADC_IN0_BOOT

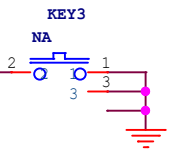

HW_ID

SARADC_IN2_HW_ID

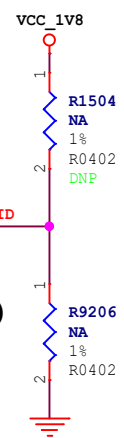

TABLE

SARADC_IN2	Rup	Rdown	ADC
HW_ID0	DNP	100K	0
HW_ID1	100K	12K	114
HW_ID2	100K	27K	228
HW_ID3	100K	51K	342
HW_ID4	100K	82K	456
HW_ID5	100K	120K	570
HW_ID6	100K	200K	683
HW_ID7	100K	330K	796
HW_ID8	100K	820K	910
HW_ID9	100K	DNP	1023

V1.0

POWER_LED

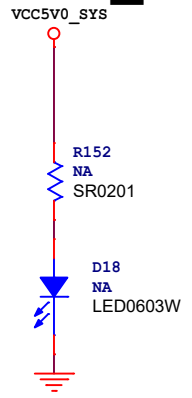

WORK_LED

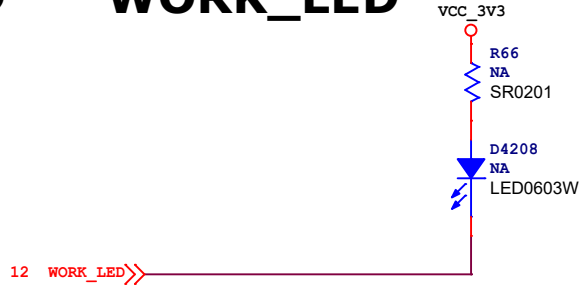

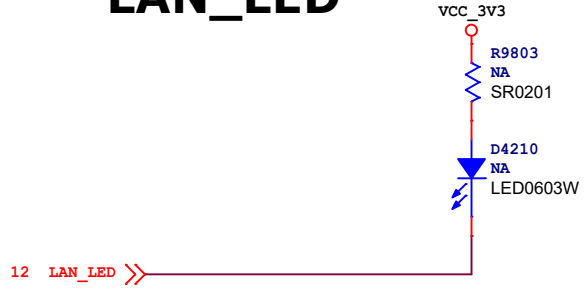

LAN_LED











WAN_LED



Title <Title>		
Size A4	Document Number <Doc>	Rev <RevC>
Date: Monday, November 13, 2023	Sheet 21	of 22

H2
NA
NP-C1P20

H4
NA
NP-C1P20

H3
NA
NP-C1P20

H2MMNA4MH1 
H2MMNA4MH5 
H2MMNA4MH6 
H2MMNA4MH7 

MARK4
NA

MARK2
NA

MARK1
NA

MARK3
NA

Title		
<Title>		
Size	Document Number	Rev
A4	<Doc>	<RevC
Date:	Monday, November 13, 2023	Sheet 22 of 22