

Assembly Instructions for
Servo-Driven Gripper Kit
SKU: 3219-0002-0002

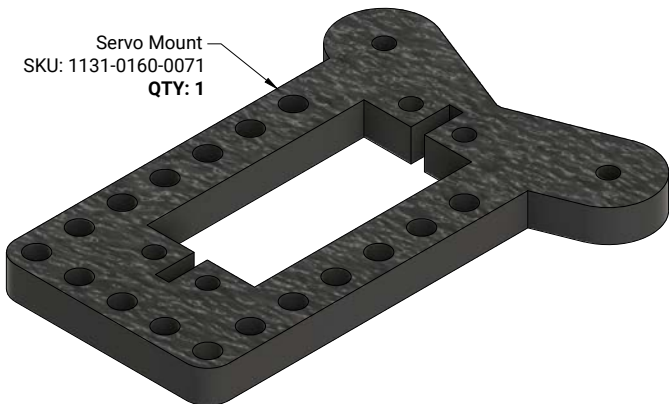

Kit Contents

Servo Mount
SKU: 1131-0160-0071
QTY: 1



Servo Horn
SKU: 1131-0040-0004
QTY: 1

Left Gripper
SKU: 1131-0160-0072
QTY: 1

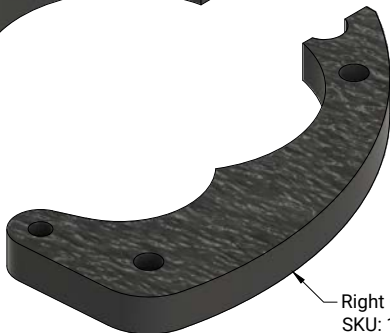

Right Gripper
SKU: 1131-0160-0073
QTY: 1

Right Linkage
SKU: 1131-0024-0007
QTY: 1

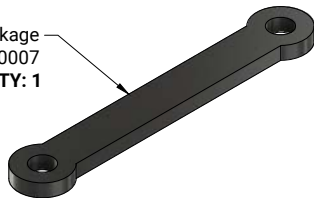

Linkage Spacer
SKU: 1131-0040-0005
QTY: 1

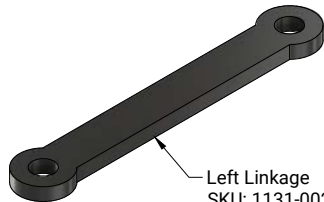

Left Linkage
SKU: 1131-0024-0008
QTY: 1

Proton Servo
SKU: 2002-0180-0002
QTY: 1



Tools Required

- 2.5mm Hex
- 3mm Hex Key

M3 Socket Head Screw
SKU: 2800-0003-0006
QTY: 1 (Included with Proton Servo)



10mm Socket Head Screw
SKU: 2800-0004-0010
QTY: 6



14mm Socket Head Screw
SKU: 2800-0004-0014
QTY: 3



3mm ID Washer
SKU: 2801-0003-0008
QTY: 1



4mm ID Washer
SKU: 2801-0004-0008
QTY: 25 (1 Pack)



STEP 1:

Use **one** 14mm Socket Head Screw and **two** 4mm ID Washers to attach **one** Right Gripper to **one** Servo Mount as shown.

After tightening the screw, loosen it slightly to allow the gripper to move freely.

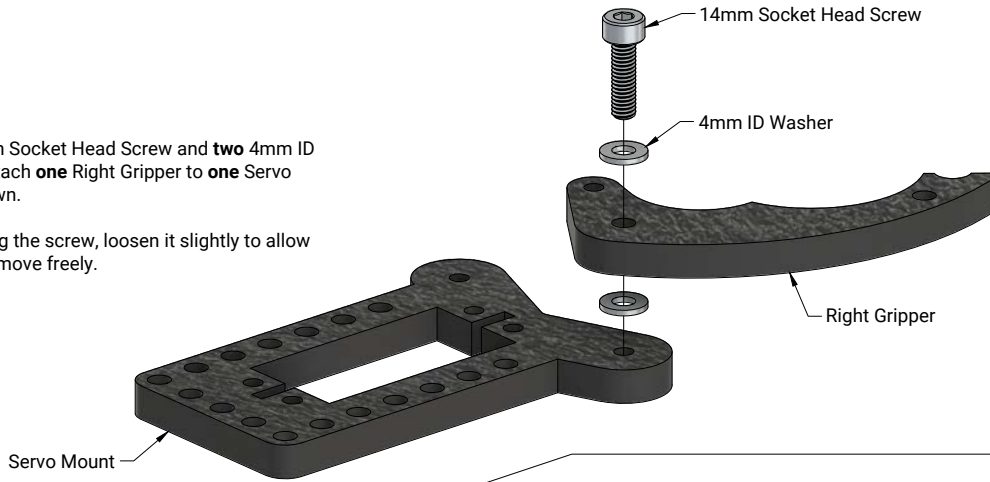

STEP 2:

Use **one** 14mm Socket Head Screw and **two** 4mm ID Washers to attach **one** Left Gripper to the Servo Mount as shown.

After tightening the screw, loosen it slightly to allow the gripper to move freely.

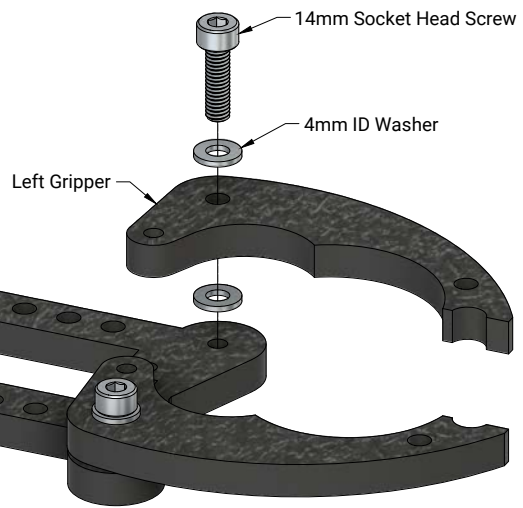

STEP 3:

Assemble **one** Left Linkage, **one** Right Linkage, and **one** Servo Horn with **one** 10mm Socket Head Screw and **one** 4mm ID Washer as shown. Note that the Right Linkage is shorter than the Left Linkage (**Figure 3-A**).

After tightening the screw, loosen it slightly to allow the linkages to move freely.

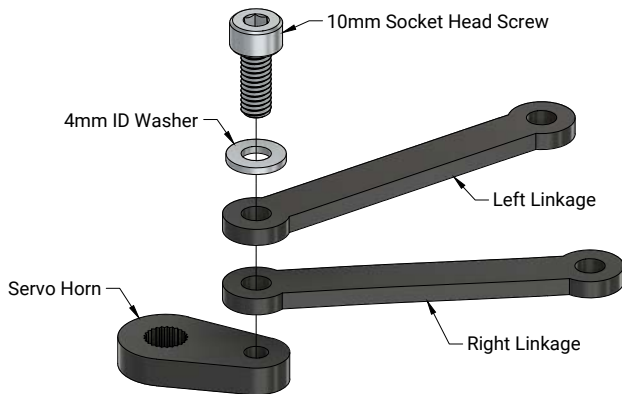
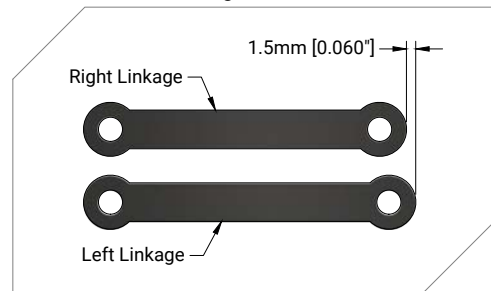
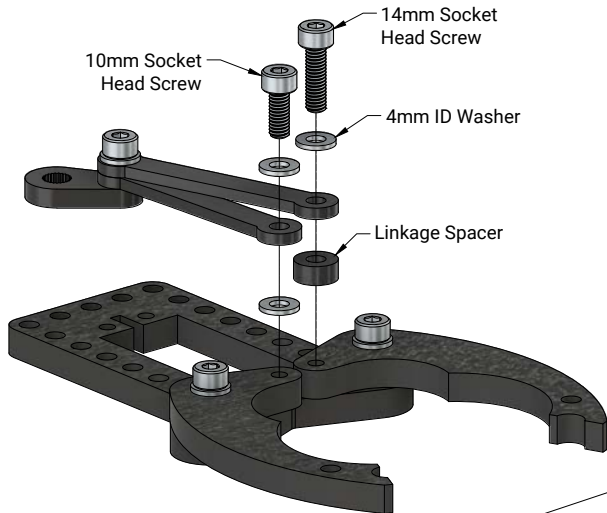

Figure 3-A





STEP 4:

Use **one** 10mm Socket Head Screw, **one** 14mm Socket Head Screw, **three** 4mm ID Washers, and **one** Linkage Spacer to attach the subassembly from **STEP 3** to the grippers as shown.

After tightening the screws, loosen them slightly to allow the gripper to move freely.



STEP 5:

Use your servo controller to rotate **one** Proton Servo clockwise to its limit (**Figure 5-A**), then rotate the Proton Servo counter-clockwise a very small distance (about 2°) (**Figure 5-B**). After completing these two servo movements, unplug your servo and close the Right Gripper and Left Gripper by hand.

Figure 5-A

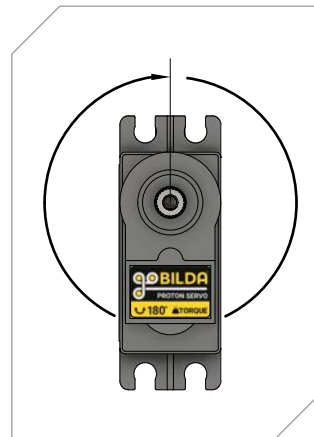
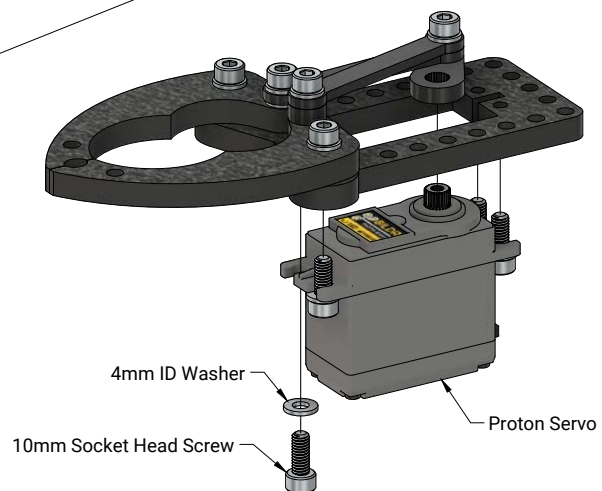

Figure 5-B



STEP 6:

Slide the Proton Servo into position while ensuring that the Proton Servo interfaces with the Servo Horn. Fix the Proton Servo place using **four** 10mm Socket Head Screws and **four** 4mm ID Washers as shown.



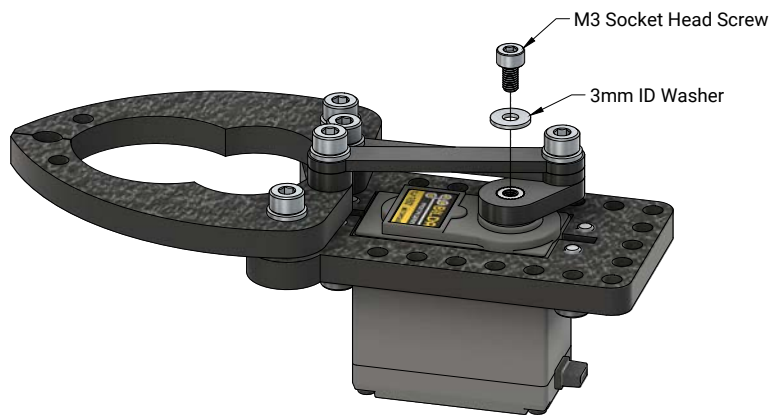

STEP 7:
Fasten the Servo Horn onto the Proton Servo using **one** M3 Socket Head Screw and **one** 3mm ID Washer as shown.

Congratulations!

Your Servo-Driven Gripper Kit is now assembled! You just built a bundle of parts into a gripping promise of project possibilities, and we can't wait to see what you do with it!

