

The “Three Fives” Discrete 555 Timer

*Re-create one of the most classic, popular,
and all-around useful chips of all time.*

The “Three Fives” Discrete 555 Timer kit from Evil Mad Scientist Laboratories is faithful and functional transistor-scale replica of the classic NE555 timer integrated circuit.

Designed by Eric Schlaepfer (tubetime.us), in collaboration with Evil Mad Scientist Laboratories.

Main Specifications

- Kit type: Through-hole soldering kit
- Assembly instructions: Printed, included with kit
- Assembly time: 30-60 minutes (typical)
- Function: Equivalent circuit to NE555 timer IC. Some performance characteristics differ; Refer to Abs. Maximum ratings and Electrical Characteristics
- RoHS compliance: All kit components are RoHS compliant (lead free)
- Connection methods: Terminal posts (bare wire, lug, or alligator clip) or solder

Block Diagram / Pinout

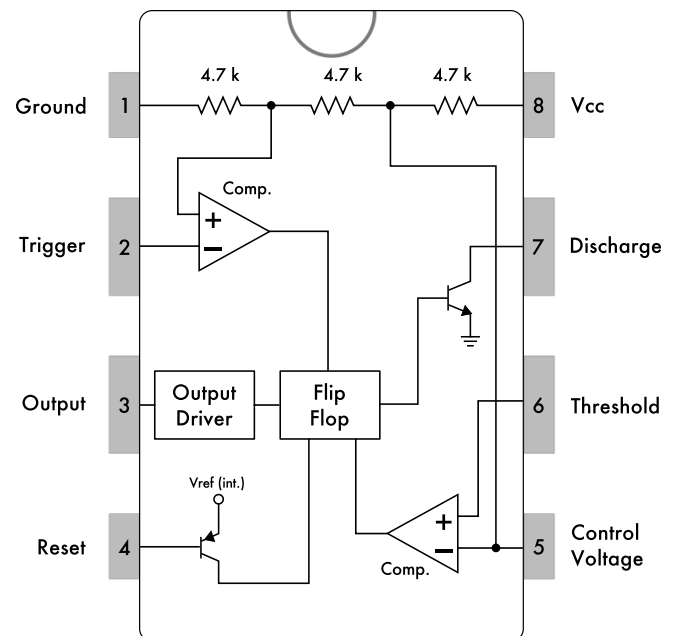

Kit Contents

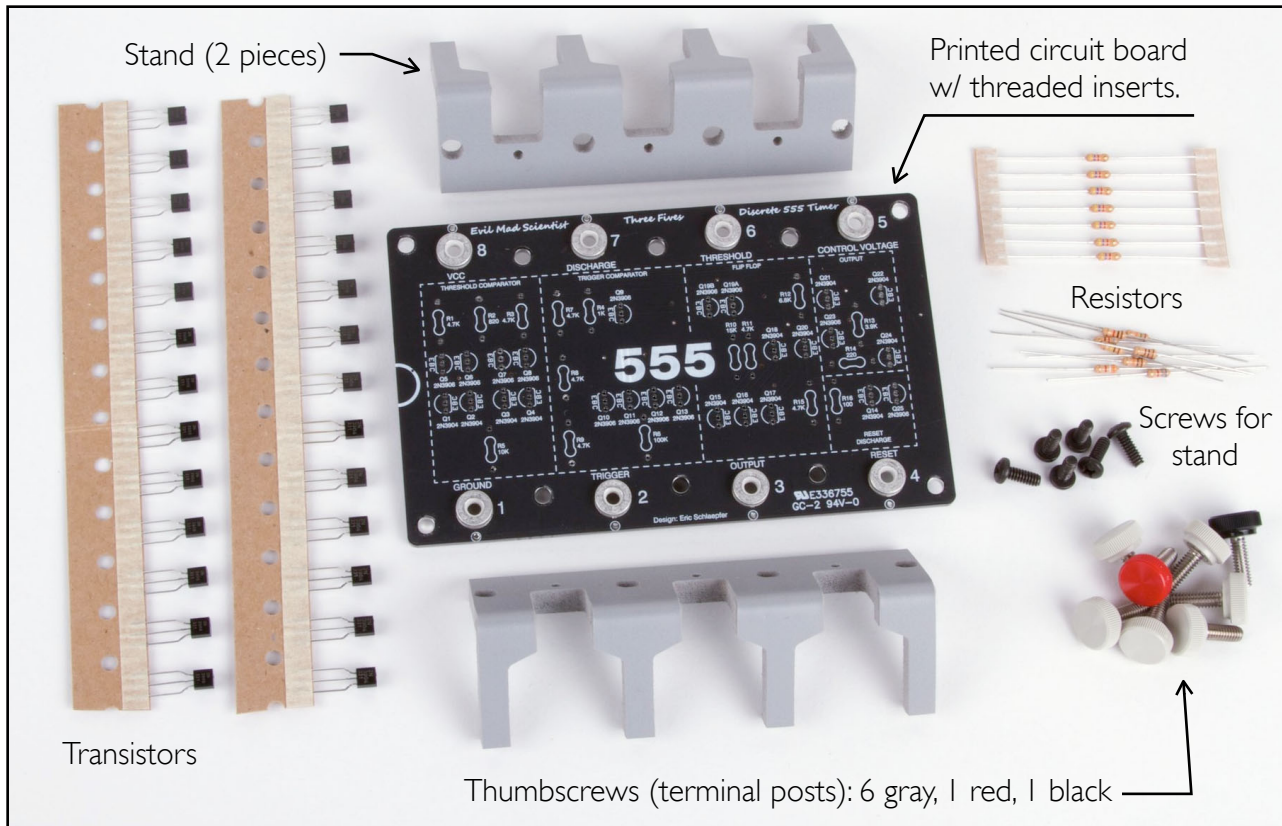

Contents of the Three Fives kit:

- The Three Fives printed circuit board (extra thick 0.100"), pre-fitted with eight 8-32 threaded inserts
- The transistors and resistors required to assemble the kit
- Eight thumbscrews (terminal posts) with color-coded caps (1 red, 1 black, 6 gray)
- Two-piece "IC Legs" stand, machined and formed from semi-rigid PVC foam
- Mounting screws for attaching the "IC Legs" stand
- Printed assembly instructions (not shown)

Tools and materials required for assembly (not included with kit):

- Soldering iron
- Solder
- Wire clippers
- Phillips head screwdriver (#2 size recommended).

Schematic Diagram

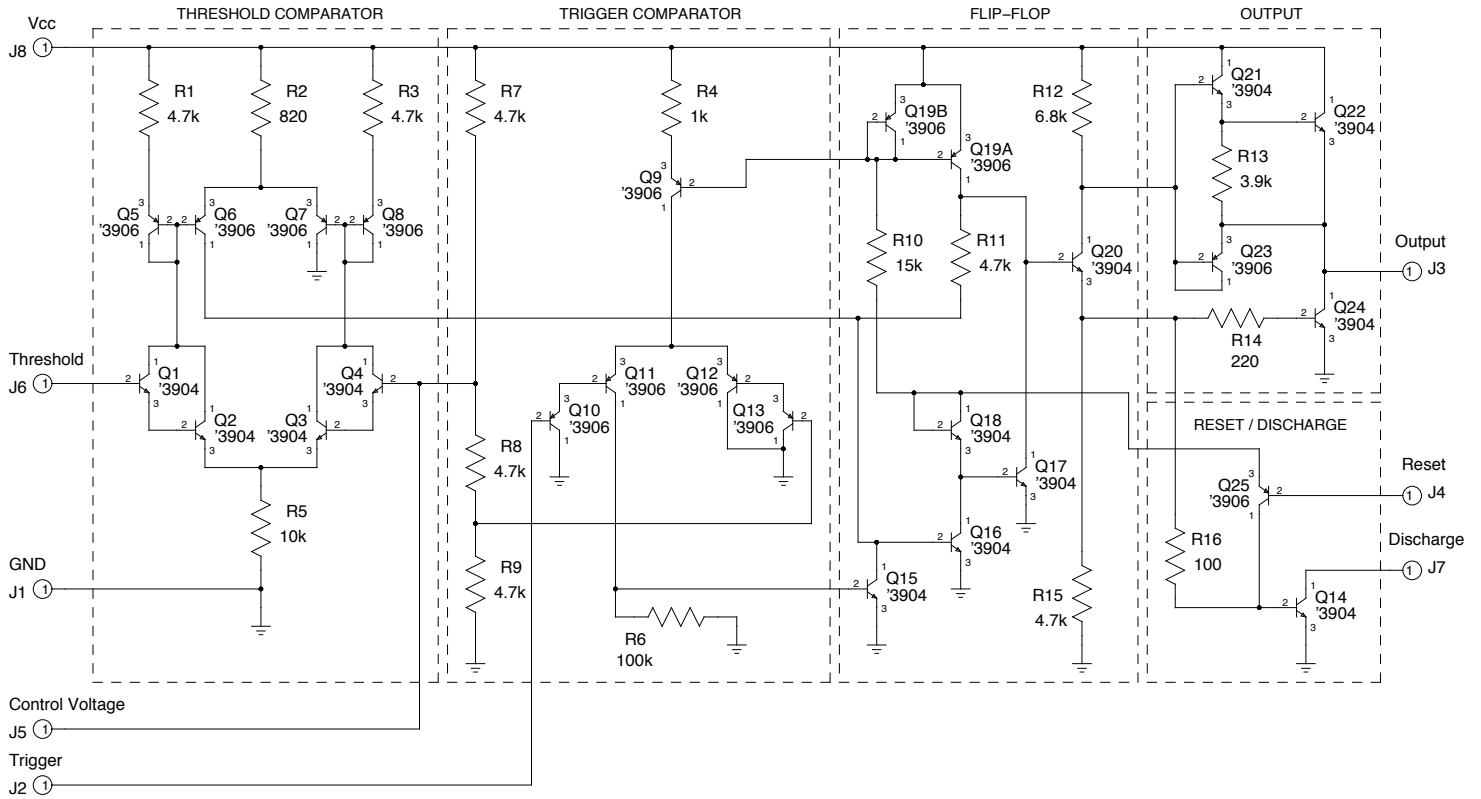

Electrical Components

Reference	Qty	Type	Value
Q1-4, Q14-18, Q20-22, Q24	13	NPN Transistor	2N3904
Q5-13, Q19A, Q19B, Q23, Q25	13	PNP Transistor	2N3906
R1, R3, R7, R8, R9, R11, R15	7	Resistor, 1/4 W	4.7 k
R2	1	Resistor, 1/4 W	820
R4	1	Resistor, 1/4 W	1 k
R5	1	Resistor, 1/4 W	10 k
R6	1	Resistor, 1/4 W	100 k
R10	1	Resistor, 1/4 W	15 k
R12	1	Resistor, 1/4 W	6.8 k
R13	1	Resistor, 1/4 W	3.9 k
R14	1	Resistor, 1/4 W	220
R16	1	Resistor, 1/4 W	100

Absolute Maximum Ratings

Parameter	Symbol	Value	Unit
Supply Voltage	V_{CC}	18	V
Output current	I_O	± 100	mA
Input voltage (Control Voltage, Threshold, Trigger pins)	V_{IN}	V_{CC}	
Input voltage (Reset pin)	V_{RST}	Lesser of V_{CC} or 6.6 V ¹	
Lead temperature (PVC foam stand)	T_{LEAD}	150	°F
		65	°C

Notes:

1. For $V_{CC} > 6.6$ V, Reset pin may be pulled up to V_{CC} with a 100 kilohm resistor.

Electrical Characteristics

Parameter	Symbol	Conditions	Min	Typ	Max	Unit
Supply Voltage	V_{CC}		4		18	V
Supply Current	I_{CC}	$V_{CC} = 5\text{ V}$, Low state		3		mA
		$V_{CC} = 15\text{ V}$, Low state		10		
Threshold Voltage	V_{TH}	$V_{CC} = 5\text{ V}$		3.3		V
		$V_{CC} = 15\text{ V}$		10.0		
Threshold Current	I_{TH}			10		nA
Trigger Voltage	V_{TR}	$V_{CC} = 5\text{ V}$		1.67		V
		$V_{CC} = 15\text{ V}$		5.0		
Trigger Current	I_{TR}	TRIG at 0 V		10		nA
Reset Voltage ¹	V_{RST}			0.4		V
Reset Current	I_{RST}			0.2		mA
Control Voltage Level	V_C	$V_{CC} = 5\text{ V}$		3.33		V
Discharge Pin Leakage	I_{LKG}			1		nA
Discharge Pin Output Voltage Low	V_{DL}	$V_{CC} = 5\text{ V}$, $I_O = -5\text{ mA}$		50		mV
Output Pin Voltage High ²	V_{OH}	$V_{CC} = 5\text{ V}$, No load		4.5		V
		$V_{CC} = 5\text{ V}$, $I_O = 100\text{ mA}$		3.3		V
		$V_{CC} = 15\text{ V}$, $I_O = 100\text{ mA}$		13.3		V
Output Pin Voltage Low ²	V_{OL}	$V_{CC} = 5\text{ V}$, $I_O = -5\text{ mA}$		50		mV
		$V_{CC} = 5\text{ V}$, $I_O = -8\text{ mA}$		100		mV
		$V_{CC} = 15\text{ V}$, $I_O = -10\text{ mA}$		0.1		V
		$V_{CC} = 15\text{ V}$, $I_O = -50\text{ mA}$		0.4		V
		$V_{CC} = 15\text{ V}$, $I_O = -100\text{ mA}$		2.0		V

Notes:

1. Specified with trigger input high.
2. For long term static operation, limit to 50 mA maximum.

Printed Circuit Board: Physical layout and mounting holes

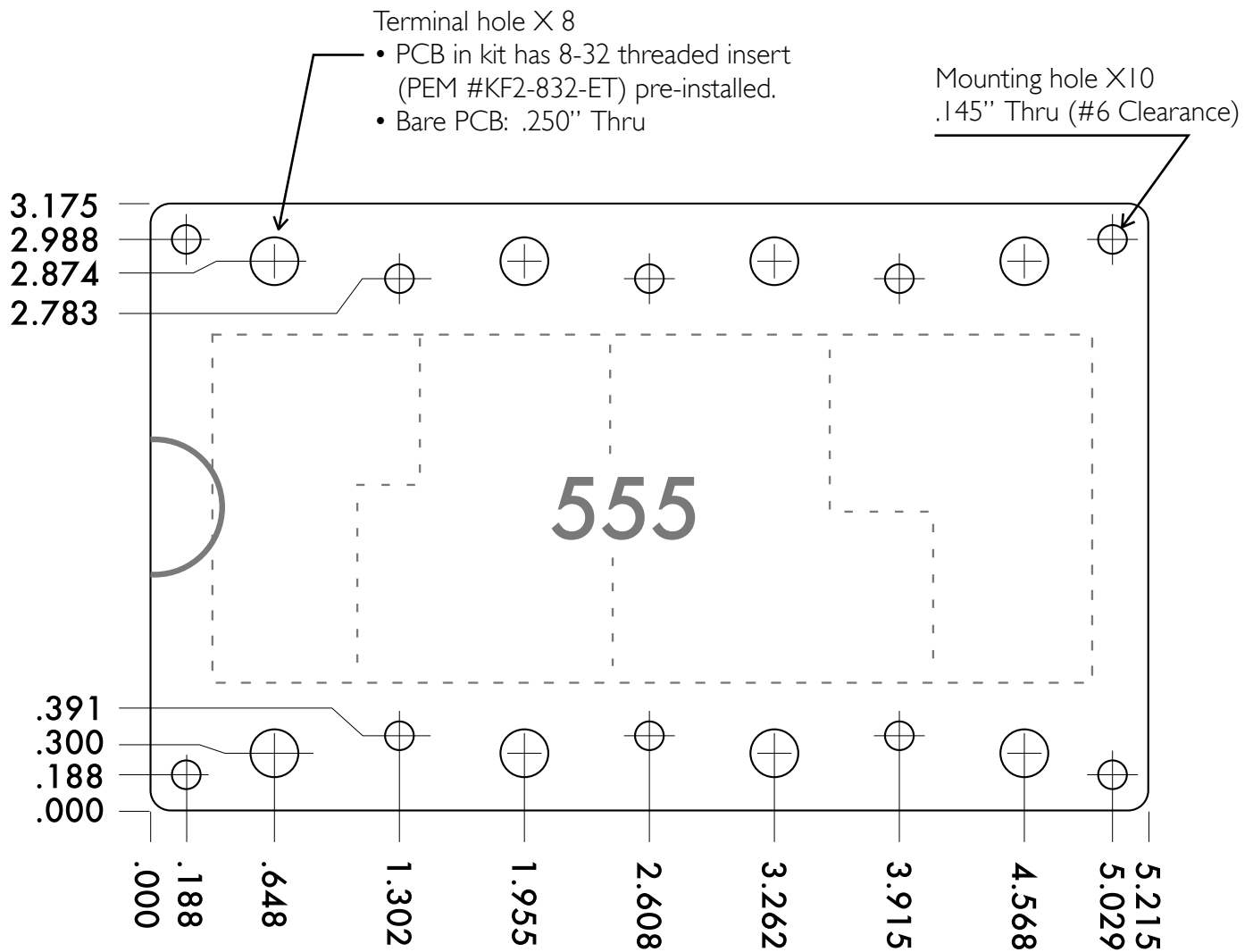

Note: All dimensions are in INCHES.

Additional physical specifications:

- Printed Circuit Board size: 5.215 X 3.175 inches (13.25 X 8.06 cm) wide
- PCB thickness: 0.100" (2.54 mm) nominal, not including threaded inserts
- PCB thickness: 0.196" (4.98 mm) nominal, including threaded inserts
- Overall thickness: Allow 0.5" min. clearance above and below circuit board
- Mounting holes: Ten #6 clearance holes provided. See drawing for locations.

Dimensions when assembled with stand and terminal posts

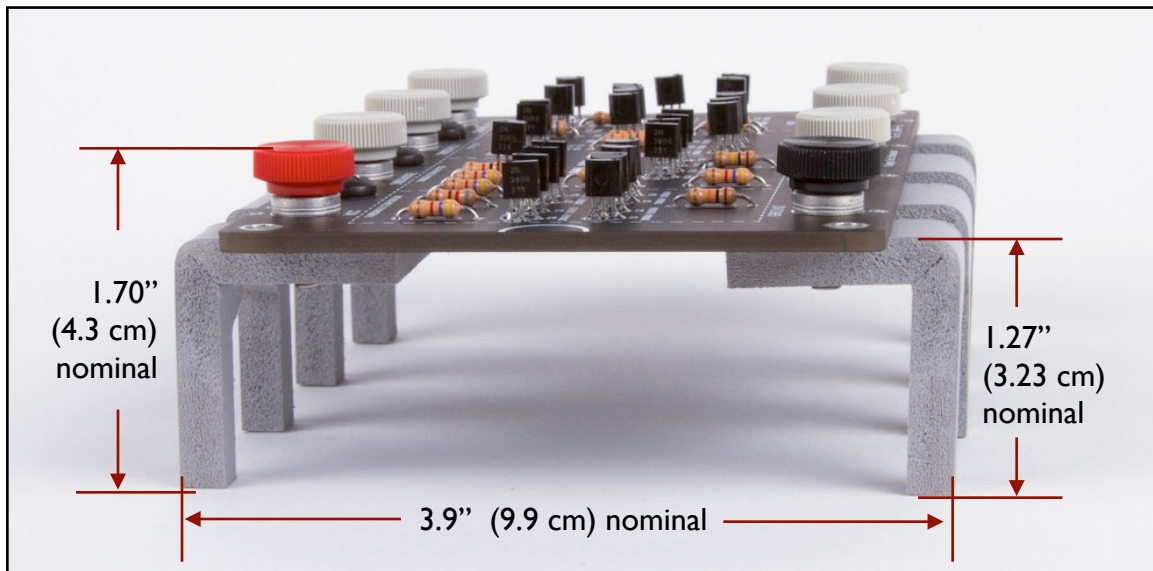
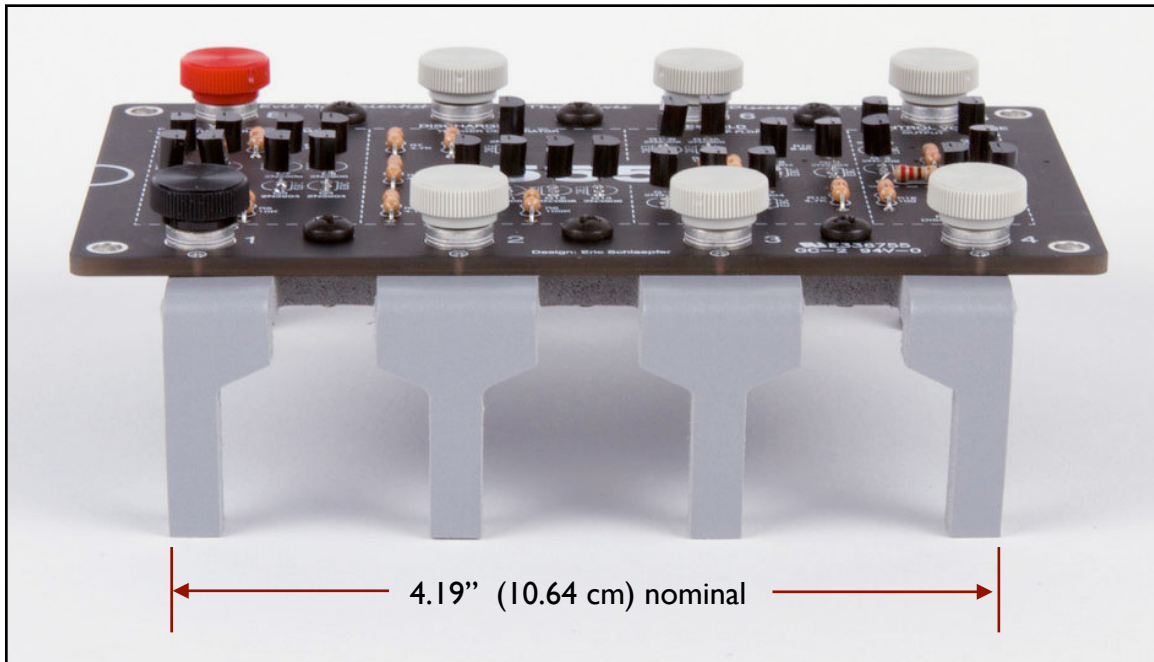

Additional Photos

Bare PCB

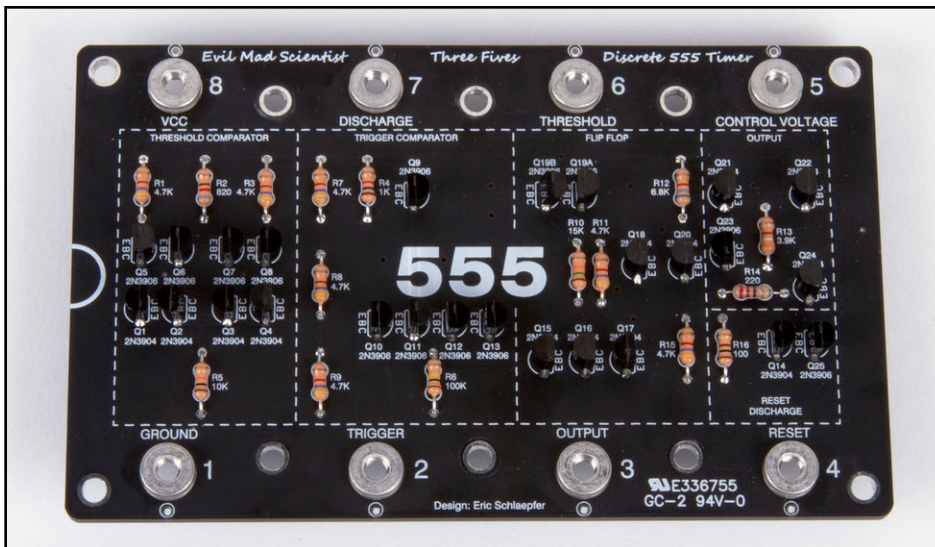
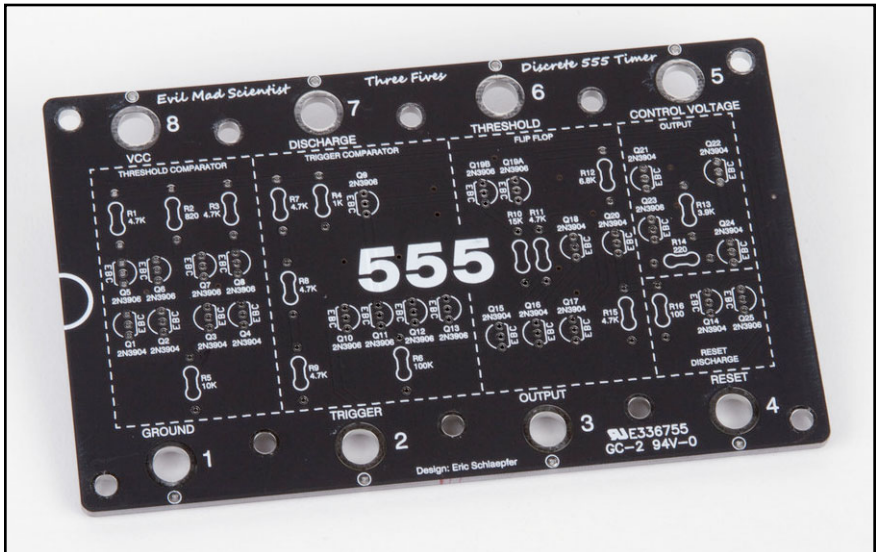

Circuit board with threaded inserts, assembled with electrical components

Assembled PCB with stand (Terminal posts removed)

