

---

## VB50A

VB50A Single-Point, Cost-Effective dToF LiDAR

---

The VB50A LiDAR is a compact and cost-effective dToF laser ranging sensor designed for drones, robotic vacuum cleaners, and industrial robots.

### Key Features

- ❖ dToF technology
- ❖ Compact design
- ❖ Strong ambient light immunity
- ❖ Easy integration



### Applications

- ❖ Drone altitude holding & obstacle avoidance
- ❖ Robot obstacle avoidance
- ❖ AGV navigation & obstacle detection
- ❖ Industrial automation & safety monitoring



## Important User Information

Thank you for choosing our product. To ensure safe and reliable operation, please read the following information carefully before use.

### 1. Safe Operation

Always follow the instructions provided in the manual. Improper use may result in device malfunction or personal injury. Keep the device away from direct eye exposure if it includes laser or optical components.

### 2. Handling and Maintenance

Handle the product with care. Avoid exposure to extreme temperatures, moisture, or dust. When cleaning, use a soft, dry cloth. Do not attempt to disassemble or modify the device, as this may void the warranty.

### 3. Specifications and Updates

Product specifications, features, and performance may change as improvements are made. Always refer to the official website for the latest technical information.

### 4. Documentation and Intellectual Property

This document is proprietary. Do not copy, alter, or translate it without written authorization.

### 5. Support and Inquiries

If you encounter any issues, questions, or need technical assistance, please contact our support team: [surertech@surertech.cn](mailto:surertech@surertech.cn)

\* Technical support: [surertech@surertech.cn](mailto:surertech@surertech.cn)

\* Sales or product information: [surertech@surertech.cn](mailto:surertech@surertech.cn)

### Headquarter Address:

13-14th Floor, Building 1, China, Railway Software Valley Headquarters, Economic Park, No. 66 Fengzhan Road, Yuhuatai District, Nanjing City, Jiangsu, Province, 210012 P.R. China

Note: Proper use and regular maintenance will help maximize device performance and longevity. Following these guidelines ensures your product operates safely and efficiently.

## Contents

1. Specifications .....	4
2. Definitions of Pins .....	5
3. Dimensions .....	5
4. Measuring Characteristic .....	6
5. Communication Protocol: UART .....	6
5.1 Communication Interface .....	6
5.2 Output Format .....	6
5.3 UART Commands .....	7
5.4 Check Function .....	8
6. Communication Protocol: IIC .....	8
7. Quick Test .....	10
8. Precautions .....	12
9. Update History .....	12

# 1. Specifications

No	Model	VB50A
1	Range	0.05m ~ 50m (90%reflectivity), 0.05m ~ 20m (10%reflectivity)
2	Frequency	100Hz
3	Accuracy	±5cm(<5m), 1%(≥5m)
4	Repeatability	±30mm
5	Ambient Light Immunity	10m@60KLux
6	Central Wavelength	905nm
7	Photobiological Safety	Class 1
8	FOV	1.9°
9	Wavelength for Indication	N/A
10	Photobiological Safety for Indication	N/A
11	Supply Voltage	3.3~5VDC
12	Peak Current	5V@70mA
13	Average Current	5V@40mA
14	Average Power Consumption	0.2W
15	Communication Interface	UART/IIC
16	Protection Level	N/A
17	Dimension	18.7 x 11.8 x 13.3mm
18	Weight	1.3g
19	Operating Temperature	-20°C ~ +60°C
20	Wire Specification	4pin 1.0mm terminal, 10cm tinned stranded wires
21	Customization	available in appearance / structure / output protocol

(Note: 1. This parameter was measured at 25°C in an indoor environment. 2. This parameter was measured with a 90% reflector in an outdoor environment at 25°C.)

## 2. Definitions of Pins

		
No.	Definition / Wire Color	User Interface
1	GND (Black)	External Power -
2	3.3~5V (Red)	External Power +
3	RX (SDA) (Green)	TX (SDA)
4	TX (SCL) (Yellow)	RX (SCL)

## 3. Dimensions

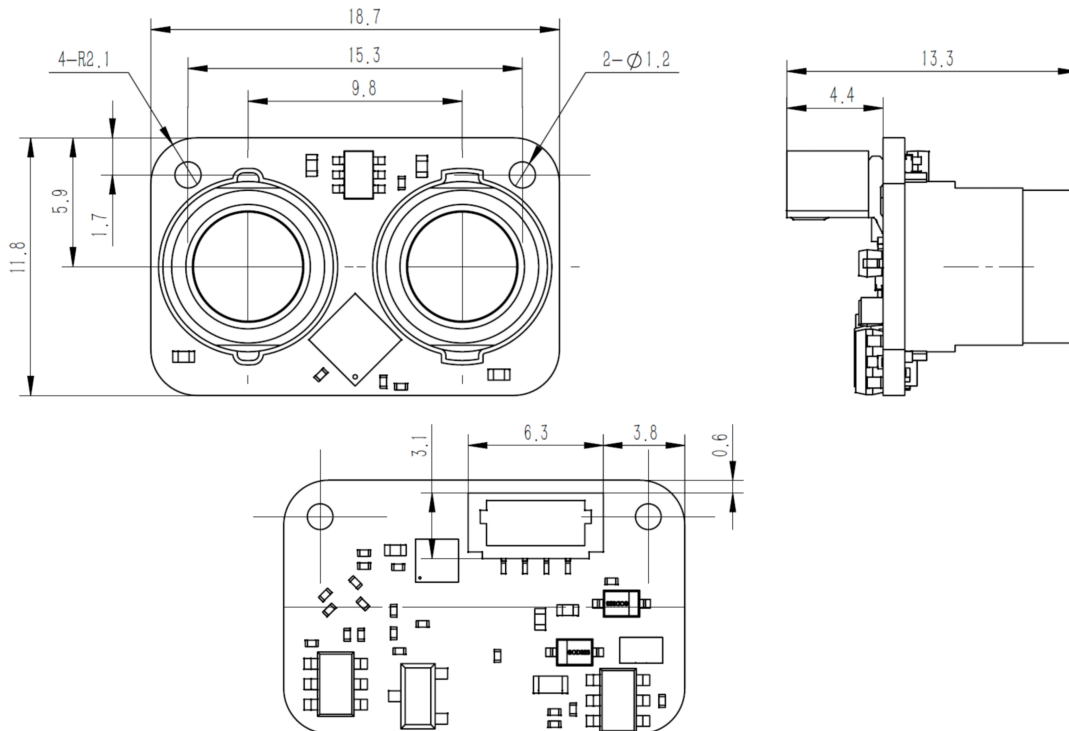

## 4. Measuring Characteristic

Due to beam divergence, the laser spot size increases with the measurement distance. To ensure accurate distance measurement, the target surface area should be larger than the laser spot at the corresponding distance.

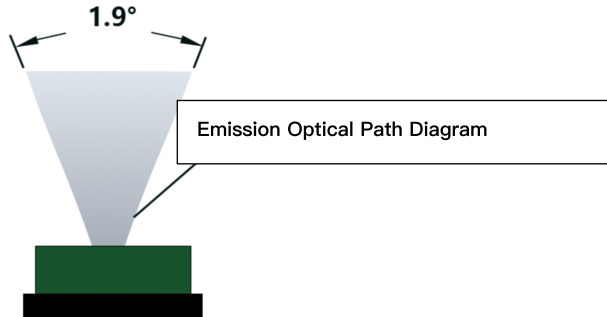

The diameters of the light spot of VB50A in different distances are shown below:

## 5. Communication Protocol: UART

Distance	1m	2m	5m	10m	20m
Diameters of the light spot	3cm	6cm	15cm	30cm	60cm

### 5.1 Communication Interface

UART	
Protocol	Free
Baud Rate	460800 (adjustable)
Data Bit	8
Stop Bit	1
Parity Bit	None

### 5.2 Output Format

Both the input and output of this product adopt the Hexadecimal Little-Endian Mode.

Frame Header	Distance 2 Bytes		Check Byte
5C	02	11	EC

4 Bytes Output

5C: Fixed Frame header 1 byte

02 11: Distance value 2 bytes means the measuring distance is 4354mm, little-endian, range 0-50000. When out of range,output would be 50000.

EC: The checksum byte is calculated by summing all bytes from the second byte (02) to the second-last byte (11), then inverting the result.

### 5.3 UART Commands

No	Description	Send	Return	Note
1	Reading serial no.	5A 0D 02 0D 0D 0D 0D BC(checksum)	5A 8D 02 10 01 00 00 5F(checksum)	10 01 00 00 means the serial no. is 272: little-endian, the serial no. shown in the upper computer is: S0000000272 (Add S before the number).
2	Reading software version no.	5A 16 02 16 16 BB(checksum)	5A 96 02 03 02 62(checksum)	03 02 means the software version no. is V2.3: little-endian, 02 represents 2, 03 represents 3, Add a point (.) in the middle.
3	Baud rate setting	5A 06 02 80 04 73(checksum)	5A 86 02 80 04 F3(checksum)	60 00 (9600) C0 00 (19200) 80 01 (38400) 80 04 (115200) 00 09 (230400) 00 0A (256000) 00 12 (460800) Any other baud rate is not available

4	Set Frequency	5A 0B 02 E7 03 08(checksum)	5A 8B 02 E7 03 88(checksum)	E7 03 (little-endian) represents the frequency divisor: 999. Output frequency: $f=10000/(999+1)=10\text{Hz}$ . Supported frequencies: 100/50/20/10/1Hz.
5	Read Frequency	5A 1B 02 1B 1B AC(checksum)	5A 9B 02 31 00 31(checksum)	31 00 (little-endian) indicates the current divisor: 49. Output frequency: $f=10000/(49+1)=200\text{Hz}$ . Supported frequencies: 200/100/50/20/10/1Hz
6	Switch to IIC	5A 1F 02 1F 1F A0(checksum)	5A 9F 02 1F 1F 20(checksum)	5A 9F 02 1F 1F 20 Response confirms successful switch.
7	Stop Ranging	5A 0A 02 00 00 F3	5A 8A 02 00 00 73	Stops distance measurement.
8	Start Ranging	5A 0A 02 02 00 F1	5A 8A 02 02 00 71	5A 8A 02 02 00 71 Initiates distance measurement.

## 5.4 Check Function

Begin with the second byte and end with the last second byte, find the inverse of the sum.

```
uint8_t Check_Sum(uint8_t *_pbuff, uint16_t _cmdLen)
{
    uint8_t cmd_sum=0;
    uint16_t i;
    for(i=0;i<_cmdLen;i++)
    {
        cmd_sum += _pbuff[i];
    }
    cmd_sum = (~cmd_sum);
    return cmd_sum;
}
```

## 6. Communication Protocol: IIC

VB50A LiDAR IIC slave interface supports maximum clock frequency 400K. The default address is 0x52 (7bit address mode).

I2C single register write sequence is as follow:

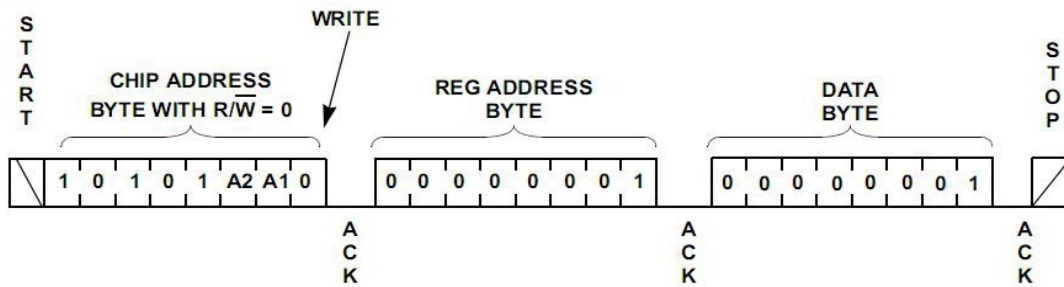

I2C multiple registers read sequence is as follow:

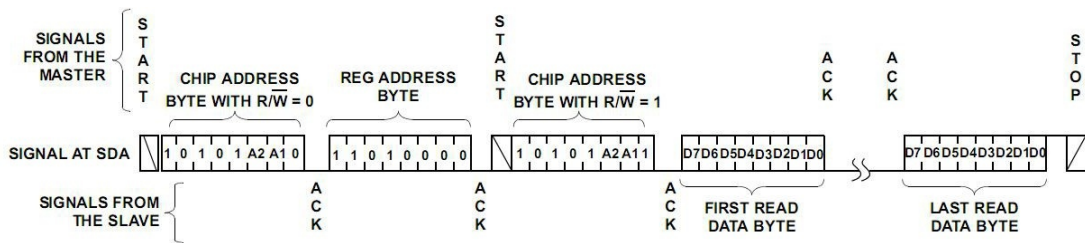

## Definitions of registers

No.	Register address	Register definition	Attribute	Remarks
0	0x00	Distance-High byte	read only	2byte for distance
1	0x01	Distance-Low byte	read only	2byte for distance
3	0x02	Laser control	write only	0: laser off; 1: laser on
4	0x03	LiDAR ID	read only	default 0x4A, be used to communicate read&write tests
5	0x04	IIC to UART Switch	Write-only	Write 0xA5 to register 0x04 and 0xA5A to register 0x05 simultaneously
6	0x05		write only	
7	0x06	Software Version - High Byte	Read-only	Software version is 2 bytes, high byte first, then low byte
8	0x07	Software Version - Low Byte	Read-only	
9	0x08	Serial Number - High Byte	Read-only	Serial number is 4 bytes, high byte first, range: 1-4294967294
10	0x09	Serial Number - Sub-high Byte	Read-only	
11	0x0A	Serial Number - Sub-low Byte	Read-only	

12	0x0B	Serial Number - Low Byte	Read-only	
13	0x0C	IIC Slave Address	Read/write	IIC slave address in 7-bit mode, range: 0-127
14	0x0D	Factory Reset	Write-only	Write 0x01 to perform factory reset

## 7. Quick Test

- TTL-to-USB converter board (3.3 V power supply) + host computer with serial port assistant.
- Universal test kit + Type-C data cable (as shown below) connected directly to the host computer.

Host computer / serial port assistant

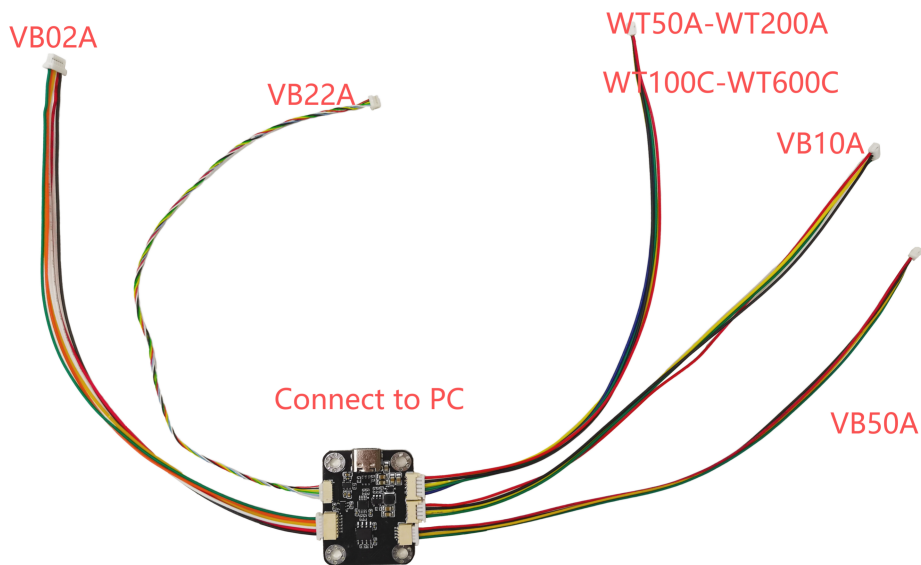

After the VB50A successfully connected to your computer , select the baud rate and click “connect” , then the data can be monitored on the upper computer.

Here is a sample figure of upper computer:

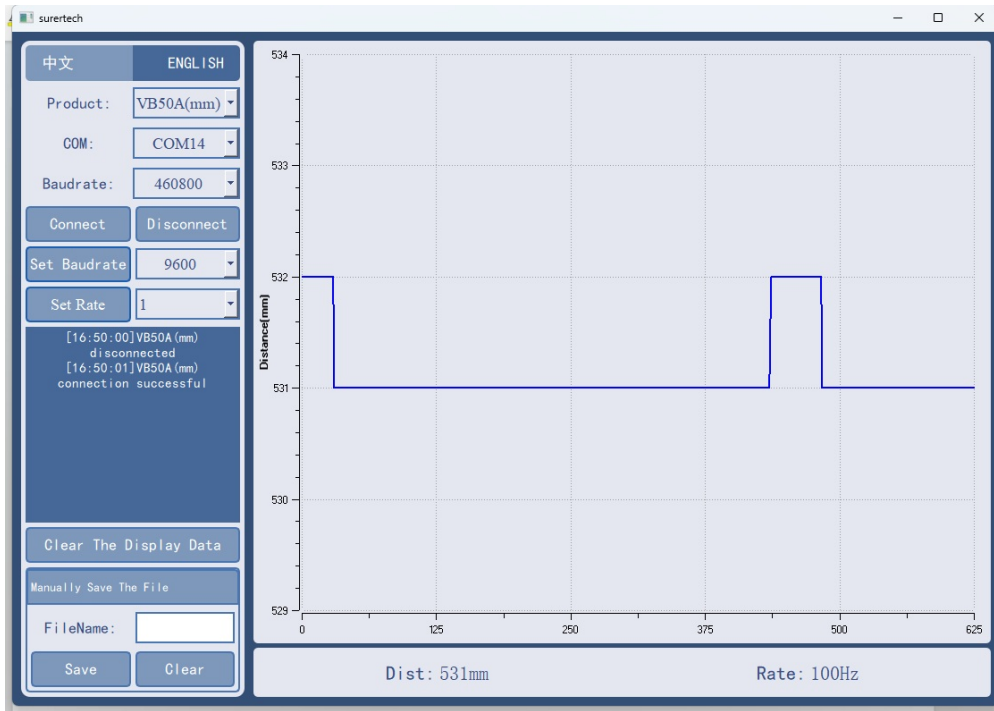

Region	Function Description
Region 1	Set serial port baud rate and other parameters for corresponding models
Region 2	Configure baud rate and frequency
Region 3	Real-time distance point-line graph
Region 4	Read real-time frequency values
Region 5	Read real-time distance values
Region 6	Save data to file
Region 7	Clear all displayed data

## 8. Precautions

- This specification is the property of Surertech and may be updated without prior notice.
- The product does not support reverse polarity or overvoltage protection. Please strictly follow the specified power supply and wiring requirements.
- The laser safety classification of this product is Class 1. Do not look directly into the lens after the device is powered on.
- When operating in dusty environments, it is recommended to place a red transparent glass or acrylic protective cover over the lens for dust protection.
- The material should have a transmittance  $\geq 85\%$  at 905 nm wavelength.
- Please wear anti-static gloves when handling the product to prevent electrostatic damage.
- Measurement errors or failures may occur when measuring highly reflective objects (e.g., 3M reflective tapes) or mirror surfaces.

## 9. Update History

Version	Date (YY/MM/DD)	Content
V0.5	24/04/29	Mass produced first editions
V1.0	24/12/30	Updated the format
V2.0	25/03/05	Revised some parameters
V2.1	25/03/31	Added the IIC protocol
V3.0	25/06/09	Expanded Function, New Host Computer Added



Address: 13-14th Floor, Building 1, China, Railway Software Valley Headquarters, Economic Park, No. 66 Fengzhan Road, Yuhuatai District, Nanjing City, Jiangsu, Province, 210012 P.R.C