

Fourth Generation 2 x 180A or 1 x 360A Brushless Motor Controller with optional Ethernet

CANopen



Roboteq's GBLG26xx is a feature-packed, high-current, high efficiency, dual or single channel controller for Brushless DC motors. It is a direct replacement for the company's popular GBL23xx, using a 4th generation processor and implementing many performance, algorithmic, and other qualitative enhancements. The controller supports a large selection of rotor position sensor types in order to generate smooth continuous rotation. The controller can be commanded via serial, USB, Analog or Pulse signals. Multiple controllers can be networked over a low-cost, twisted pair CANbus networks.

The GBLG26xx uses the latest motion control technology, such as field-oriented control (FOC), acceleration/velocity Feedforward, and fast loop frequency to deliver quick and precise motion control in speed, torque or position modes. Numerous safety features, including Safe Torque Off (STO) are incorporated into the controller to ensure reliable and safe operation. For mobile robot applications, the controller's two motor channels can either be operated independently or mixed to move and steer a vehicle.

The controller's operation can be extensively automated and customized using its built-in scripting language. The controller can be configured, monitored and tuned in real-time using a Roboteq's free PC utility. The controller can also be reprogrammed in the field with the latest features by downloading new operating software from Roboteq.

Applications

- Automatic Guided Vehicles
- Small Electric Vehicles, Electric Bikes
- Terrestrial and Underwater Robotic Vehicles
- Police and Military Robots
- Hazardous Material Handling Robots
- Balancing Robots
- Telepresence Systems

Key Features

- USB, Serial, 0-5V Analog, or Pulse (RC radio) command modes
- RS232 and RS485 serial ports
- Optional 10/100 Ethernet
- MODBUS ASCII and RTU Support over RS232 or RS485. MODBUS TCP Support over Ethernet
- CAN bus up to 1 Mbit/s. Multi-Protocol support
 - CANOpen DS402
 - RoboCAN Meshed Network
 - RawCAN Customizable to Any Protocol
- Auto switch between Serial, USB, CAN, Ethernet, Analog, or Pulse based on user-defined priority
- Built-in dual 3-phase high-power drivers for two brushless DC motors
- 2x180A Max, 2x120A continuous Current with I2T protection algorithm
- Programmable current limit up to 180A (360A on single channel version) per motor for protecting controller, motor, wiring and battery.
- Output channels can be paralleled in order to drive a single motor at up to 360A (Requires special firmware)
- 97% or better typical Efficiency
- Supports Surface Permanent Magnet (SPM) motors or Internal Permanent Magnet (IPM) motors
- Multiple Motor Operating mode
 - Trapezoidal with Hall Sensors
 - Sinusoidal with Hall+Encoder
 - Sinusoidal with Encoders
 - Sinusoidal with Hall Sensors
 - Sinusoidal with Absolute Encoder
- Support for absolute angle encoders
 - Sin/Cos analog
 - SSI (single-turn and multi-turn)
 - Resolver

- Field Oriented Control in Sinusoidal modes
- Full forward & reverse motor control. Four quadrant operation. Supports regeneration
- Operates from a single 10V-60V power source
- STO - Safe Torque Off support
- Accurate speed and Odometry measurement using Hall Sensor or Encoder data
- Up to 8 Analog Inputs for use as command and/or feedback
- Up to 8 Pulse Length, Duty Cycle or Frequency Inputs for use as command and/or feedback
- Up to 10 Digital Inputs for use as Deadman Switch, Limit Switch, Emergency stop or user inputs
- Inputs for up to 2 Quadrature Encoders
- 4 general purpose 1.5A open collector outputs for brake release or accessories
- Custom scripting in Basic language. Execution speed up to 100000 lines per second
- Selectable min/max, center and deadband in Pulse and Analog modes Selectable exponentiation factors for each command inputs
- Trigger action if Analog, Pulse, Encoder or Hall counter capture are outside user selectable range (soft limit switches)
- Open loop speed control operation
- Closed loop speed, position and/or torque control
- Closed loop position control with encoder, hall sensors, analog or pulse/frequency feedback
- Cascaded Speed, Position, Torque PID loops
- High-Performance 16kHz Current Control loop
- Automatic Tuning of Torque, Speed and Position loops
- Automatic Field Weakening for maximum Speed & Torque
- Automatic Motor Characterization
- Advanced performance optimization algorithms (Anti-cogging, notch filter, Decoupling control, ...)
- Support for NTC temperature sensors through analog inputs (requires an external pull-up resistor)
- Configurable Data Logging of operating parameters on Serial Outputs for telemetry or analysis
- Separate Programmable acceleration and deceleration
- Built-in Battery Voltage and Temperature sensors
- Optional 14V backup power input for powering safely the controller if the main motor batteries are discharged
- Power Control wire for turning On or Off the controller from external microcomputer or switch
- Regulated 5V output for powering RC radio, RF Modem, sensors or microcomputer
- Separate Programmable acceleration and deceleration for each motor
- Ultra-efficient 1.2 mOhm ON resistance MOSFETs (0.6 mOhm on Single Channel)
- Stall detection and selectable triggered action if Amps is outside user-selected range
- Short circuit protection
- Overvoltage and Undervoltage protection
- Watchdog for automatic motor shutdown in case of command loss
- Overtemperature protection
- Diagnostic LED indicators
- Efficient heat sinking. Operates without a fan in most applications.
- Built-in conduits for liquid cooling
- Dustproof and weather resistant. IP40 rating
- Power wiring using High Current M6 screw terminals
- 210mm x 145mm x 60mm
- -10° to +70° C operating environment
- Weight: 6.5 lbs (2940g)
- Easy configuration, tuning and monitoring using provided PC utility
- Field upgradeable software for installing latest features via the Internet

Orderable Product References

Reference	Number of Channels	Amps/Channel Max/Cont	Volts	Ethernet
GBLG2660T	2	180	60	No
GBLG2660TE	2	180	60	Yes
GBLG2660TS	1	360	60	No
GBLG2660TES	1	360	60	Yes

Warning

A dangerous uncontrolled motor runaway condition can occur due to various reasons, including, but not limited to: command or feedback wiring failure, configuration errors, faulty firmware, errors in user scripts or programs, or controller hardware failure.

Users must be aware that such failures can occur and must ensure the safety of their system under all conditions. Roboteq will not be held liable for any damage or injury resulting from product misuse or failure.

Important Note

All products are not serviceable. If damage is suspected, the item must be replaced rather than repaired.

Attempting to service or repair the product voids any existing warranty and may pose safety risks.

Consult customer support for more information on replacements.

Power Terminals Identifications and Connection

Power connections are made by means of high amperage power terminals located at the top of the controller, as shown in Figure 1

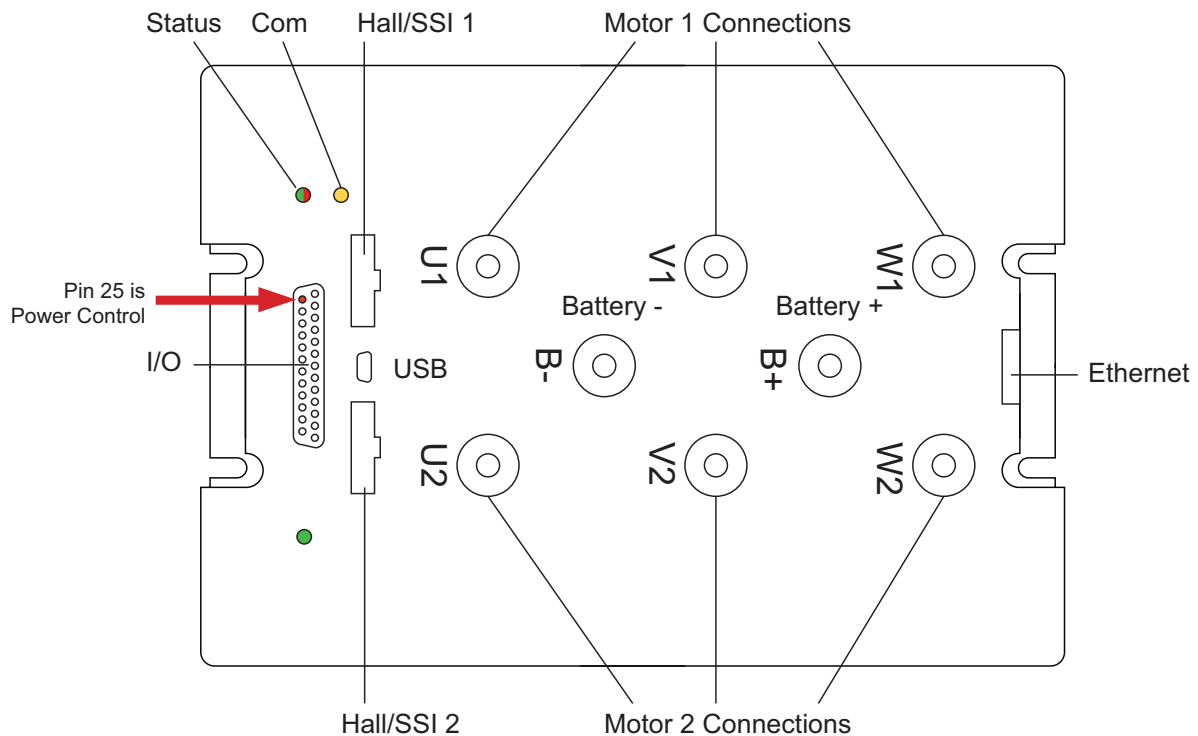

FIGURE 1. GBLG26xx Connectors and Terminals location

The diagram in Figure 2, below, shows how to wire the controller in a dual motor configuration, and how to turn power On and Off.

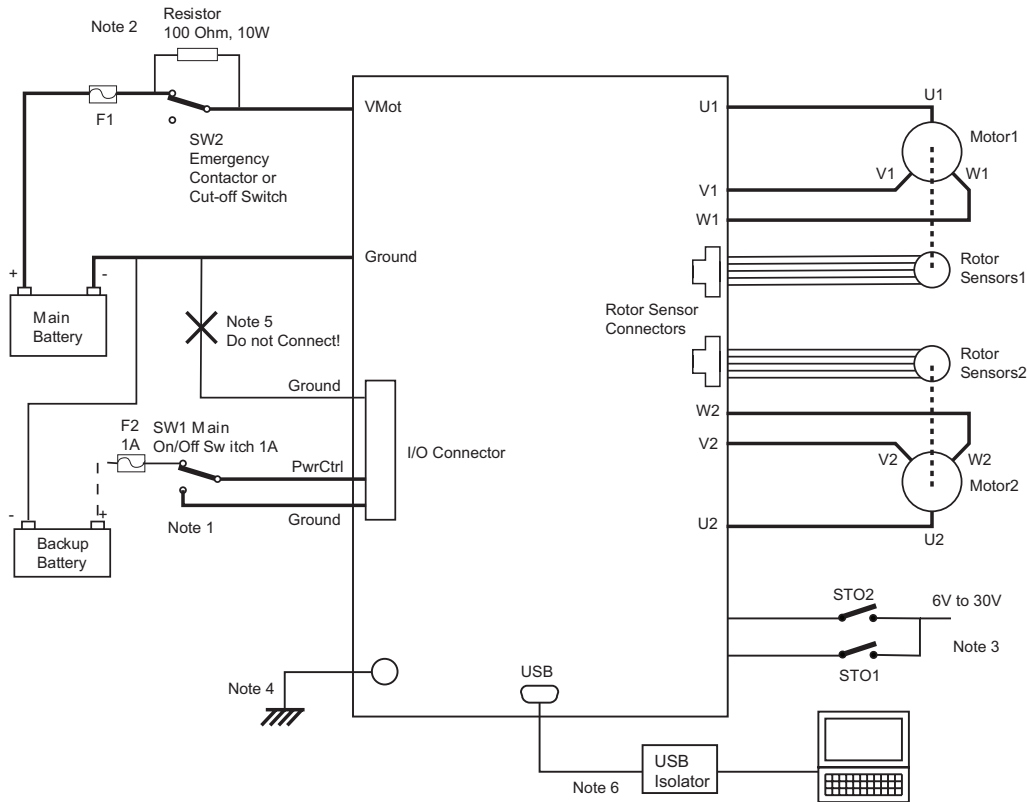

FIGURE 2. Powering the Controller. Thick lines identify MANDATORY connections

Caution

Carefully follow the wiring instructions provided in the Power Connection section of the Roboteq Controllers User Manual. The information on this datasheet is only a summary.

Mandatory Connections

It is imperative that the controller is connected as shown in Figure 2 in order to ensure a safe and trouble-free operation. All connections shown as thick black lines are mandatory.

Emergency Switch or Contactor

The battery must be connected Permanently to the controller’s VMot tab via a high-power emergency switch or contactor SW2. The user must be able to deactivate the switch or contactor at any time, independently of the controller state. SW2 should be used only in emergency situations and not for normal operation. Opening SW2 while the motors are rotating can lead to permanent hardware damage. Use a suitable high-current fuse F1.

Power On/Off Switch

The controller must be powered On/Off using switch SW1 on the Power Control pin.

Note 1: To ensure motor operation with weak or discharged batteries, connect a second battery to the Power Control pin via the SW1 switch. This will keep the controller alive and responding even if no voltage is present on the VMot terminal.

Precharge Resistor

The controller has internal capacitance which will cause a brief yet significant current inrush the moment power is applied.

Note 2: If there is a concern that this current can overload the power supply, fuse and/r the contactor, insert a precharge resistors as shown in figure 2. For precharging to take place, the controller must be turned off by grounding the Power Control pin.

Connection to Chassis

Note 4: For improved EMI immunity and reduced emissions, it is recommended to connect the controller's bottom plate to the system's chassis. Note that the integrated controller's ground is not DC-electrically connected to the plate. However, there is a capacitor between the controller's ground and the bottom plate, providing AC conductivity.

Avoid Alternate Ground Paths

Note 5: Be cautious not to create a path between the ground pins on the I/O connector and the battery's negative terminal. An internal connection already exists between the battery's negative pole and the control ground. Avoiding an additional external connection is highly recommended, as this could allow current to circulate in the signal ground, potentially introducing noise into low-power signals. If the main power ground terminal becomes loose or disconnected, very high current from the motor may flow through the signal ground wire, causing damage.

Electrostatic Discharge Protection

In accordance with IEC 61000-6-4, Roboteq Motor Controllers are designed to withstand ESD up to 4kV touch and 8kV air gap. This protection is implemented without any additional external connections required.

Some specifications, such as EN12895, require a higher level of protection. To maximize ESD protection, up to 8kV touch and 15kV air gap, connect the metallic heatsink of the controller to the battery's negative terminal.

Precautions When Connecting PC via USB

Note 6: Always use a USB isolator to protect both the drive and the PC against potential electrical damage. When using a portable PC, operate it on battery power to avoid creating an accidental return ground path via the charger.

Controller Mounting

The drive should be mounted in such a way that its bottom surface makes direct contact with a metallic surface, such as the system chassis or cabinet. This will assist in dissipating the heat generated during the operation of the controller. It's important to note that the nominal and peak ampere values documented in the datasheet can only be fully achieved with adequate cooling.

Single Channel Wiring

On the Single Channel GBLG26xxS, each of the motor wires must be connected to both output tabs labeled with the same letter, as shown in figure 3. The sensors connected to Channel One will be used for the motor's operation.

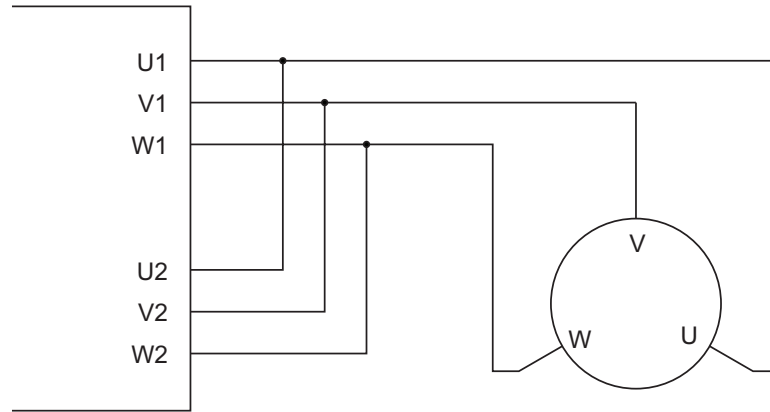

FIGURE 3. Single Channel Wiring Diagram

Caution

This wiring must be done only on the single channel version of the controller. Paralleling the wires on a dual channel product will cause permanent damage. Verify that your controller is an GBLG2660S before you wire in this manner.

Hall Sensors Connection

Connection to the Hall Sensors is done using a 6-pin Molex Microfit 3.0, ref. 43645.

Pin assignment are in Table 1, below.

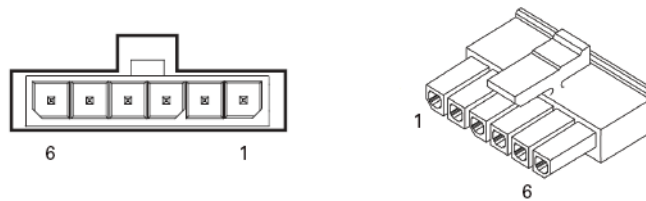

FIGURE 4. Hall Sensors Connector

TABLE 1.

Pin Number	1	2	3	4	5	6
Signal	Ground	Hall A	Hall B	Hall C		5V

Important Note

Hardware revisions prior to 1.4 have a maximum supported sensor frequency of 16 kHz.

Connection to SSI Absolute Encoder

Both multi-turn and single-turn SSI sensors are supported in sinusoidal mode, with pure binary encoding (no Gray code, offset binary, etc.) and a resolution of up to 48 bits. These SSI sensors must be connected to the 6-pin Molex connectors, which are also used for Hall sensors. The specific sensor connected to the Molex connectors can be determined through the controller's configuration settings. The controller employs differential signals for both clock and data. The Molex connector pin assignment for the SSI sensor is shown in Table 2.

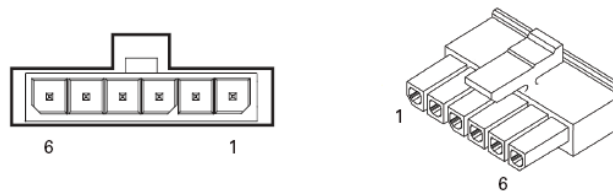

FIGURE 5. Hall Sensor Connector Used for SSI Encoders

TABLE 2.

Pin Number	1	2	3	4	5	6
Signal	Ground	Data +	Data –	Clock +	Clock –	5V

Connection to Analog Sin/Cos Absolute Encoder

The GBLG2660 features four high-speed analog inputs, designed to capture the absolute angular position data from either resolvers or magnetic sensors that have sin/cos voltage outputs. For the sin/cos sensors, the signal must range from 0 to 5V, with 0 at 2.500V. Table 3, below, shows the signals assignment on the 25-pin connector.

TABLE 3.

Signal	Pin Number	Pin Name
Sin1	9	ASIN1
Cos1	10	ACOS1
Sin2	24	ANA7/ASIN2
Cos2	12	ANA8/ACOS2

Connecting Resolver

The wiring for the resolver is similar to a Sin/Cos sensor with the addition of an excitation signal. Figure 6, below, shows the necessary connections.

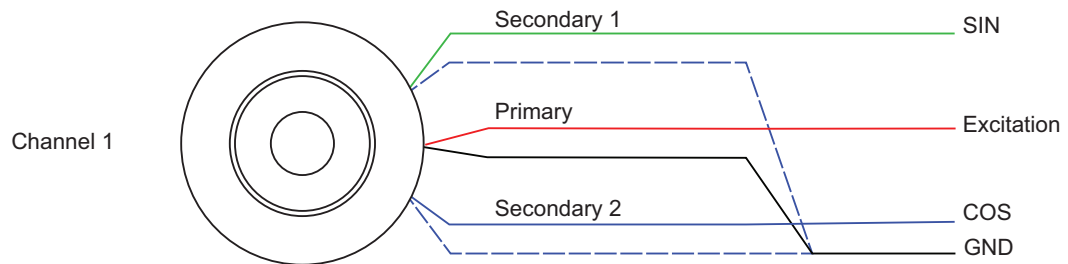

FIGURE 6. Resolver Connections

Table 4, below, shows the signals assignment on the 15-pin connector.

TABLE 4.

Signal	Pin Number	Pin Name
Sin1	9	ASIN1
Cos1	10	ACOS1
Sin2	24	ANA7/ASIN2
Cos2	12	ANA8/ACOS2
Excitation	17	ANA4/EXC

Important Note

Sensor error detection should be disabled when performing motor/sensor setup through USB, as the protection might be triggered due to signal interference. This interference will not affect the motor/sensor setup process or motor control.

Commands and I/O Connections

Connection to external devices, such as RC radios, microprocessors, joysticks, sensors, and low current actuators, is done through the DB25 connector. The controller is equipped with general-purpose inputs that can be configured to function as digital, analog, or pulse inputs. Additionally, it features open collector outputs capable of driving resistive or inductive loads of up to 1 A. The pin assignment can be found on table 5.

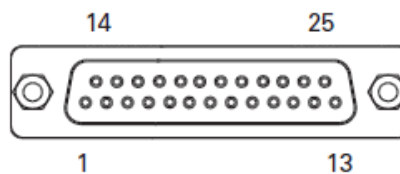

FIGURE 7. Main Connector Pin Locations

TABLE 5.

Connector Pin	Power	Dout	Com	Pulse	Ana	Dinput	STO	Encoder
1	GND							
14	5VOut							
2			RSTxD					
15				RC1 (2)	ANA1	DIN1	STO1 (1)	
3			RS RxD					
16				RC2 (2)	ANA2	DIN2	STO2 (1)	
4				RC3	ANA3	DIN3		
17				RC4 (3)	ANA4/EXC	DIN4		
5	GND							
18		DOUT1						
6		DOUT2						
19		DOUT3						
7		DOUT4						
20			CANH					
8			CANL					
21				RC5 (4)	ANA5	DIN5		ENC2A
9					ASIN1	DIN9		
22				RC6 (4)	ANA6	DIN6		ENC2B
10					ACOS1	DIN10		
23			485+					
11			485-					
24				RC7	ANA7/ASIN2	DIN7		ENC1A
12				RC8	ANA8/ACOS2	DIN8		ENC1B
25	PwrCtrl							
13	GND							

Note 1: STO jumper must be removed for STO signals to be active

Note 2: Not compatible with MultiPWM inputs.

Note 3: Input has high internal capacitance. Not recommended for capture of fast pulses

Note 4: Not compatible with multiPWM when SSI sensor is used.

Enabling Analog Commands

The Analog command mode is disabled by default. To enable this mode, use the PC utility and set "Analog" in Command Priority 2 or 3 (leave "Serial" as priority 1). Note that by default, additional safety features are enabled, preventing the motor from starting unless the potentiometer is centered, or if the voltage is below 0.25V or above 4.75V. Use the PC utility to enable and assign analog inputs.

Connecting Thermistors

NTC temperature sensors can be connected to the controller’s analog inputs. This enables reading of motor temperature through the controller’s runtime variables and allows for active temperature protection. This connection can be achieved by using a pull-up resistor with a value equal to the thermistor’s resistance between the analog input and the controller’s 5V output. For more information about motor temperature readings and controller parameterization, please refer to the Roboteq Controller’s User Manual.

USB communication

Use the USB only for configuration, monitoring, and troubleshooting purposes. USB is not a reliable method of communication and can lead to disconnections when used in electrically noisy environments. These disconnections often require resetting the USB connection or even the controller. For more reliable interfacing with a computer, always opt for RS232 communication.

Important Note

Always use a USB isolator to protect both the drive and the PC from potential electrical damage. When using a portable PC, operate it on battery power to avoid an accidental ground path return via the charger.

CAN Communication

CAN is the GBLG26xx’s primary and recommended communication interface. Up to 127 drives can be networked on a twisted pair network up to 1000m long and at speeds up to 1Mbit/s. Roboteq support four CAN protocols:

- CANOpen for interoperability with other vendor’s DS301 and DS402 compliant devices
- RoboCAN, a simple and effective peer to peer meshed network protocol
- MiniCAN, a simplified subset of CANOpen PDOs
- Raw CAN, a low-level system used with scripting for constructing and parsing CAN frames to handle any protocols

TABLE 6. CANOpen Communications Specification

Feature	Value
Motion Network type	CAN, CANOpen
CANOpen Standards Support	DS301, DS402
Operating Modes	Cyclic sync torque, cyclic sync velocity, cyclic sync position, profile position, profile velocity, profile torque modes, homing
Process Data Objects (PDO)	Cyclic sync and free run modes. Cyclic messages can be set for 20 objects on 4 maps

RS485 Communication

RS485 is a robust industry standard for serial communication, well-suited for long distances and electrically noisy industrial settings. It uses balanced signaling for enhanced stability, allowing the connection of multiple receivers on a single network. The protocol supports half-duplex operation and is particularly compatible with Modbus. The 25-pin connector features designated pins for RS485+ and RS485-.

Important Note

In some models, RS485 communication requires two 10 kΩ resistors to be connected to the A and B signals of the bus as follows:

- One resistor should be connected from the A signal to the controller’s 5V output.
- One resistor should be connected from the B signal to the controller’s ground.

Optional Ethernet Communication

Ethernet communication is only available on the E versions of the controller. The connection port is located on the top of the unit for easy and rapid access. Communication occurs via TCP/IP. Commands can be in Serial over TCP and Modbus TCP. Serial over TCP is the preferred method to access all native commands.

Two LEDs are present on the Ethernet jack, as shown in Figure 8. The left Yellow LED will be On when operating as 100 Mbps connection and Off when as 10 Mbps. The right Green LED will blink when data activity is present.

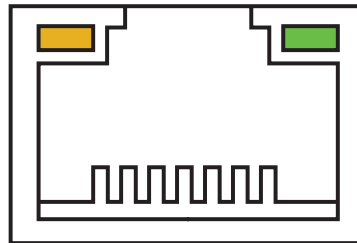

FIGURE 8. Ethernet LED Configuration

Important Note

TCP Mode and CAN Mode cannot work in conjunction on “E” type controllers; only one can be active at a time. By default, TCP Mode is enabled and CAN Mode is disabled, allowing for a plug & play TCP connection. To switch to CANOpen, the user must manually disable TCP Mode and enable CAN Mode. To revert to Ethernet, TCP Mode must be enabled and CAN Mode disabled by the user.

Status LED Flashing Patterns

After the controller is powered on, the Power LED will turn on, indicating that the controller is active. The Status LED will flash at two-second intervals. The flashing pattern and color provide information on operating status or exceptions.

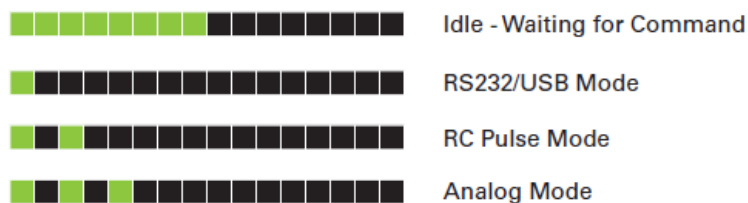

FIGURE 9. Normal Operation Flashing Patterns

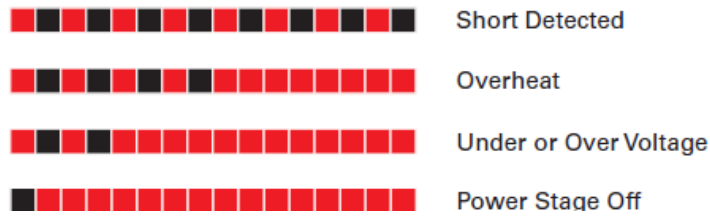

FIGURE 10. Exception or Fault Flashing Patterns

Additional information about the controller’s status and fault conditions can be obtained by monitoring the controller through the PC utility. The Communication LED indicates the status of USB and CAN Bus connectivity.

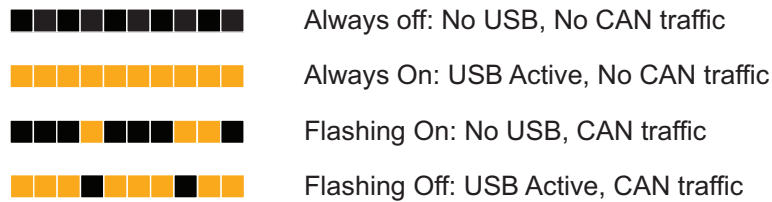

FIGURE 11. Communication LED Flashing Patterns

Safe Torque Off - STO

Safe Torque Off (STO) is a secure method for switching the controller into a state where no torque is generated, regardless of whether the controller is operating normally or is faulty. The STO functionality is achieved through redundant circuitry, incorporated into the STO1 and STO2 inputs of the controller. For the controller to operate normally, both STO inputs must be supplied with a voltage ranging from 6 to 30V. The controller performs a self-test of the STO circuitry every time it powers on, or when both STO inputs go high. If the STO circuitry is found to be functioning properly, the controller will allow the motor to be energized. In the event of an STO failure or if not both STO inputs are in a high state, the power stage will be cut off. Since STO is a hardware implementation and has been verified and validated by Roboteq, it can be trusted to bring the motor to a no-torque condition without the need for an external relay to cut power to the motor. For more information about STO functionality, refer to the STO Manual.

Figure 12 illustrates the STO operation. To properly trigger the STO, both STO inputs must be in a high state. To properly release the STO, both STO inputs must be low. Having only one of the two STO inputs in a high state will trigger the “STO fault” alarm.

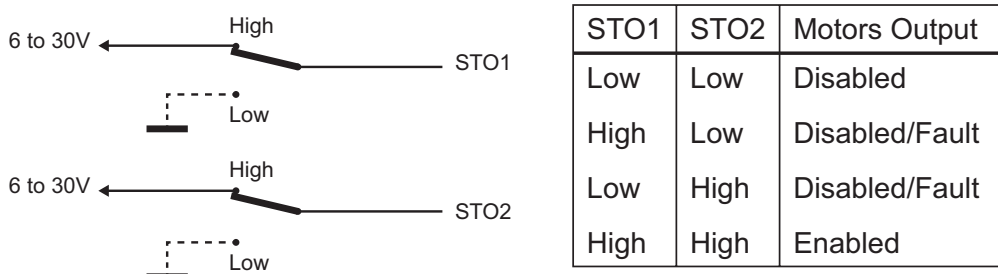

FIGURE 12. STO input levels effects on controller output

Connection to SSI Absolute Encoder

RoboG4 DC products support pure binary encoding (no Gray code, offset binary, etc.) SSI sensors in single-turn version, with a resolution of up to 16 bits. These SSI sensors must be connected to the 6-pin Molex connector, which is also used for Encoder sensors. The specific sensor connected to the Molex connector can be determined through the controller's configuration settings. Please note that the SSI sensor is supported only on channel 1 and channel 2. The Molex connector pin assignment for the SSI sensor is shown in Table 7.

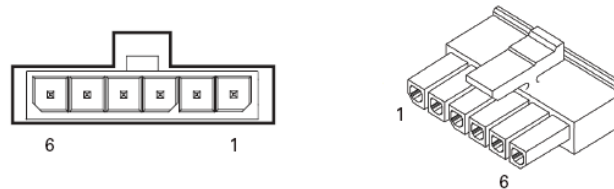

FIGURE 13. SSI Connector

TABLE 7.

Pin Number	1	2	3	4	5	6
Signal	Ground	Data +	Data –	Clock +	Clock –	5V

Electrical Specifications

Absolute Maximum Values

The values in Table 8 should never be exceeded, as doing so may result in permanent damage to the controller.

TABLE 8.

Parameter	Measure point	Min	Typ	Max	Units
Battery Leads Voltage	Ground to Vmot			63	Volts
Reverse Voltage on Battery Leads	Ground to VBat	-1			Volts
Power Control Voltage	Ground to Pwr Control wire			63	Volts
Motor Leads Voltage	Ground to U, V, W wires			63 (1)	Volts
Digital Output Voltage	Ground to Output pins			30	Volts
Analog and Digital Inputs Voltage	Ground to any signal pin on 15-pin & Encoder inputs			30	Volts
Hall inputs voltage	Ground to Hall inputs of Molex connector			5.5	Volts
RS232 I/O pins Voltage	External voltage applied to Rx/Tx pins			30(2)	Volts

Note 1: Maximum motor voltage including regeneration. Never inject a DC voltage from a battery or other fixed source
 Note 2: No voltage must be injected on TxD pin

Power Stage Electrical Specifications (at 25°C ambient)

TABLE 9.

Continuous Max Current per channel	Measure point	Model	Min	Typ	Max	Units
Battery Leads Voltage	Ground to VBat	All	0 (1)		60	Volts
Motor Leads Voltage	Ground to U, V, W wires	All	0 (1)		60 (2)	Volts
Power Control Voltage	Ground to Power Control wire	All	0 (1)		60	Volts
Minimum Operating Voltage	VBat or Pwr Ctrl wires	All	14 (3)			Volts
Over Voltage protection range	Ground to VBat	All	5	60 (4)	60	Volts
Under Voltage protection range	Ground to VBat	All	0	5 (4)	50	Volts
Input Capacitance	Ground to VBat	All		12500		uF
Idle Current Consumption	VBat or Pwr Ctrl wires	All	50	100 (5)	150	mA
ON Resistance (Excluding Wire resistance)	VBat to U, V or W. Ground to U, V or W	GBLG2660		1.2		mOhm
		GBLG2660S		0.6		mOhm
Max Current for 30s	Motor current	GBLG2660			180	Amps
		GBLG2660S			360	Amps
Continuous Max Current per channel	Motor current	GBLG2660			120 (6)	Amps
		GBLG2660S			240 (6)	Amps
Current Limit range	Motor current	GBLG2660	10	120 (7)	180	Amps
		GBLG2660S	20	240 (7)	360	Amps
Stall Detection Amps range	Motor current	GBLG2660	10	180 (7)	180	Amps
		GBLG2660S	20	360 (7)	360	Amps
Stall Detection timeout range	Motor current	All	1	500 (8)	65000	ms
Short Circuit Detection threshold (9)	Between Motor wires or Between Motor wires and round	GBLG2660			330 (10)	Amps
		GBLG2660S			660 (10)	Amps
Short Circuit Detection threshold	Between Motor wires and VBat	All	No Protection. Permanent damage will result			

Note 1: Negative voltage will cause a large surge current. Protection fuse needed if battery polarity inversion is possible
 Note 2: Maximum regeneration voltage in normal operation. Never inject a DC voltage from a battery or other fixed source
 Note 3: Minimum voltage must be present on VBat or Power Control wire
 Note 4: Factory default value. Adjustable in 0.1V increments
 Note 5: Current consumption is lower when higher voltage is applied to the controller's VBat or PwrCtrl wires
 Note 6: Estimate. Limited by case temperature. Current may be higher with better cooling
 Note 7: Factory default value. Adjustable in 0.1A increments
 Note 8: Factory default value. Time in ms that Stall current must be exceeded for detection
 Note 9: Controller will stop until idle command given in case of short circuit detection
 Note 10: Approximate value

Command, I/O and Sensor Signals Specifications

TABLE 10.

Parameter	Measure point	Min	Typ	Max	Units
Main 5V Output Voltage	Ground to 5V pins on	4.6	4.75	4.9	Volts
5V Output Current	5V pins on RJ45 and DSub15			200 (1)	mA
Digital Output Voltage	Ground to Output pins			60	Volts
Output On resistance	Output pin to ground		0.25	0.5	Ohm
Output Short circuit threshold	Output pin	1.7		3.5	Amps
Digital Output Current	Output pins, sink current			1.5	Amps
Input Impedances (except DIN11-19)	AIN/DIN Input to Ground		53		kOhm
Digital Input 0 Level	Ground to Input pins	-1		1	Volts
Digital Input 1 Level	Ground to Input pins	3.8		30	Volts
Analog Input Range	Ground to Input pins	0		5.1	Volts
Analog Input Precision	Ground to Input pins		0.5		%
Analog Input Resolution	Ground to Input pins		1		mV
Pulse durations	Pulse inputs	20000		10	us
Pulse repeat rate	Pulse inputs	50		250	Hz
Pulse Capture Resolution	Pulse inputs		1		us
Minimum Pulse on or Pulse off duration	Pulse inputs	25			us
Frequency Capture	Pulse inputs	100		1000	Hz
Encoder Frequency	Encoder input pins			200	kHz
SSI Frequency	SSI input pins	680		10800	kHz
Note 1: Sum of all 5V Out outputs					

Operating & Timing Specifications

TABLE 11.

Parameter	Measure Point	Min	Typical	Max	Units
Command Latency	Command to output change	0	0.5	1	ms
Maximum PWM duty cycle	Motor Output			93.8	%
Current Loop update rate	Internal		16000		Hz
Closed Loop update rate	Internal		1000		Hz
RS232 baud rate	Rx & Tx pins		115200 (1)		Bits/s
RS232 Watchdog timeout	Rx pin	1 (2)		65000	ms
Note 1: 115200, 8-bit, no parity, 1 stop bit, no flow control					
Note 2: May be disabled with value 0					

Motor Characteristics Requirement for FOC current control

For proper FOC current control and motor operation under sinusoidal commutation, it is necessary for the motor to meet a minimum load inductance, minimum time constant (L/R) and maximum electric operating speed requirements. The minimum required inductance is necessary to ensure low Total Harmonic Distortion (THD) of the motor current. Furthermore, to achieve proper current control and stability, the controller's current loop sampling rate will determine the minimum permissible motor time constant and the maximum operating electric speed.

TABLE 12.

Parameter	Input DC Voltage (V)	Value	Units
Minimum load phase inductance (1)	24	40	uH
	48	60	uH
	60	80	uH
Minimum load inductance/resistance ratio (1)	0 - 60	0.063	msec
Maximum operating electric speed (2)	0 - 60	96000	RPM

Note 1: Star connected three phase load considered. In case the motor phase inductance does not fulfill the above requirements (minimum phase inductance and inductance/resistance ratio) an external AC inductor with proper inductance value is recommended to be added.

Note 2: Maximum rotor speed is calculated from the maximum operating electric speed and pole pairs. For example, in a motor with 4 pole pairs the maximum operating rotor speed is $96000/4 = 24000$ rpm

Scripting

TABLE 13.

Parameter	Measure Point	Min	Typical	Max	Units
Scripting Flash Memory	Internal		32000		Bytes
Integer Variables	Internal		4096		Words (1)
Boolean Variables	Internal		8192		Symbols
Execution Speed (2)	Internal	30,000		70,000	Lines/s

Note 1: 32-bit words

Note 2: Execution Speed was calculated based on low communication load with the controller. In high communication workload, minimum time might be reduced drastically.

Thermal Specifications

TABLE 14.

Parameter	Measure Point	Min	Typ	Max	Units
Heatsink Temperature	Heatsink			75 (1)	°C
Thermal Protection range	PCB	0		90 (2)	°C
Power Dissipation	Case			70	Watts
Thermal resistance	Power MOSFETs to case			0.8	°C/W
Humidity	Case			93 (3)	%
Ambient temperature	Ambient	-10		70	°C
Storage temperature	Ambient	-20		80	°C

TABLE 14.

Parameter	Measure Point	Min	Typ	Max	Units
Pollution Degree	PD2				
Fast fuse to install (4)	GBLG2660T (5)		2 x 180		Amps
	GBLG2660TS (5)		2 x 180		Amps
Overload motor protection	-	Check note 6			
<p>Note 1: The motor drive features overtemperature protection, derating current and power when internal temperature reaches 85°C. Keep the cooling plate temperature below 75°C to maintain rated current at maximum ambient temperatures.</p> <p>Note 2: Max allowed power will start degrade from the selected value.</p> <p>Note 3: Non-condensing</p> <p>Note 4: There are two power terminal tabs. Fuse should be installed in both of them for safety</p> <p>Note 5: Install 180A fuse on each of the Battery+ power terminals. Power source must be capable to blow the fuse instantly in case of short circuit</p> <p>Note 6: Current limiting mechanism available through firmware. External overload motor protection can be used if required (provided by user)</p>					

STO Specifications

TABLE 15.

Parameter	Measure Point	Min	Typ	Max	Units
STO Input High Level	Ground to STO input pin		6	30 (1)	Volts
STO Input Low Level	Ground to STO input pin		0	1	Volts
STO Response Time	Input to output change		5		msec
STO Self Check Time	Internal		1080		msec
Cable Length	2				m
EMC Immunity	According to IEC 61800-3 and IEC 61800-5-2 Annex E				
CE Declaration	Available at www.roboteq.com				

Mechanical Specifications

TABLE 16.

Parameter	Measure Point	Min	Typical	Max	Units
Weight	Board		2940 (6.5)		g (lbs)
Power Terminals	Terminal		M6		
Torque	D-sub standard connector		0.4 (3.54)		Nm (in-lbs)
Torque	Terminal block		0.8 (7.10)		Nm (in-lbs)
Torque	Mounting screws (4/M2.5)		0.36 (3.2)		Nm (in-lbs)
IP rating			IP40		

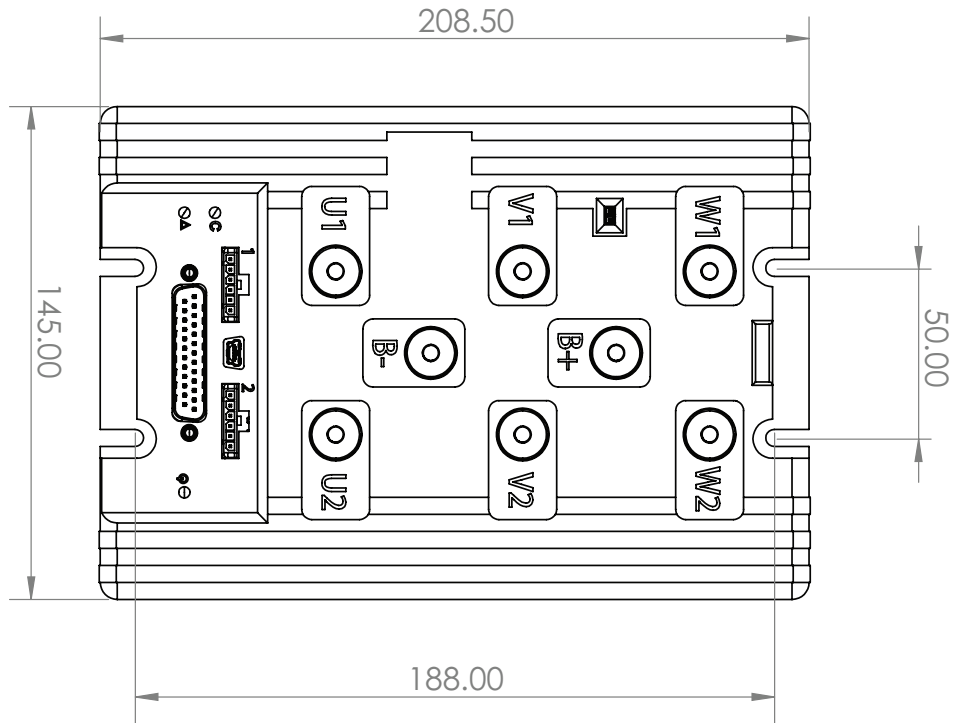

FIGURE 14. GBLG26xx top view and dimensions

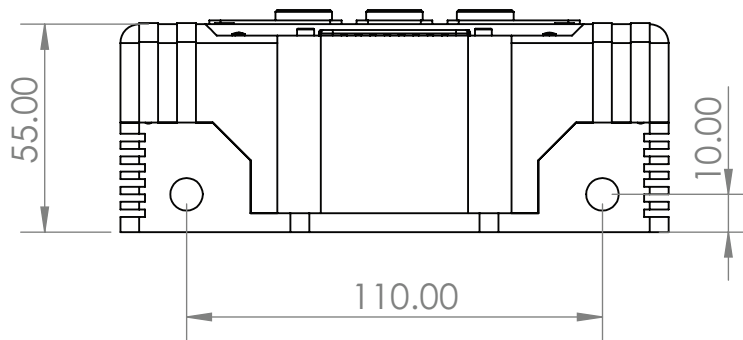

FIGURE 15. GBLG26xx side view and dimensions