

## Fourth Generation 2 x 60A or 1 x 120A Brushless DC Motor Controller

**CANopen****PROFINET****EtherCAT****EtherNet/IP**

RoboteQ's FBLG2360T is a features-packed, low-voltage, high-current, dual or single channel controller for brushless DC motors. It is a direct replacement for the company's popular FBL2360, using a 4th generation processor and implementing many performance, algorithmic, and other qualitative enhancements. The controller can be commanded via serial, USB, Analog or Pulse signals. Multiple controllers can be networked over a low-cost, twisted pair CANbus network. The controller can be ordered with EtherCAT for high speed robotics systems, or Profinet/EthernetIP for integration in factory automation applications.

The FBLG2360T uses the latest motion control technology, such as field-oriented control (FOC), acceleration/velocity feed forward, and fast loop frequency to deliver quick and precise motion control in speed, torque or position modes. Numerous safety features, including Safe Torque Off (STO) are incorporated into the controller to ensure reliable and safe operation. For mobile robot applications, the controller's two motor channels can either be operated independently or mixed to move and steer a vehicle

Numerous safety features are incorporated into the controller, including Safe Torque Off (STO). The controller's operation can be extensively automated and customized using Basic Language scripts. The controller can be configured, monitored and tuned in real-time using a RoboteQ's free PC utility. The controller can also be reprogrammed in the field with the latest features by downloading new operating software from Roboteq.

### Applications

- Automatic Guided Vehicles
- Small Electric Vehicles, Electric Bikes
- Terrestrial and Underwater Robotic Vehicles
- Multi-Axis Robot Arms
- Factory Automation
- Telepresence Systems

### Key Features

- USB, Serial, 0-5V Analog, or Pulse (RC radio) command modes
- RS232 and RS485 serial ports
- MODBUS ASCII & RTU Support over RS232 or RS485
- CAN bus up to 1 Mbit/s. Multi-Protocol support
  - CANOpen DS402
  - RoboCAN Meshed Network
  - RawCAN Customizable to Any Protocol
- Optional EtherCAT Interface CANOpen over EtherCAT (CoE)
- Optional Profinet interface
- Optional EthernetIP interface
- Auto switch between Serial, USB, CAN, fieldbus, Analog, or Pulse based on user-defined priority
- Built-in dual 3-phase high-power drivers for two brushless DC motors
- 2x60A Max, 2x40A continuous Current with I2T protection algorithm
- Output channels can be paralleled in order to drive a single motor at up to 120A
- Programmable current limit up to 60A (120A on single channel version) per motor for protecting controller, motor, wiring and battery.
- Supports Surface Permanent Magnet (SPM) motors or Internal Permanent Magnet (IPM) motors
- 97% or better typical Efficiency
- Multiple Motor Operating mode
  - Trapezoidal with Hall Sensors
  - Sinusoidal with Hall+Encoder
  - Sinusoidal with Encoders
  - Sinusoidal with Hall Sensors
  - Sinusoidal with Absolute Encoder
- Support for absolute angle encoders
  - Sin/Cos analog
  - SSI

- Resolver
- Field Oriented Control in Sinusoidal modes
- Automatic Field Weakening for maximizing motor speed and torque
- Full forward & reverse motor control. Four quadrant operation. Supports regeneration
- Operates from a single 12V-60V power source
- STO - Safe Torque Off (Certification Pending)
- Separate connector for Hall Sensors
- Accurate speed and Odometry measurement using Hall Sensor or Encoder data
- Up to 8 Analog Inputs for use as command and/or feedback
- Up to 8 Pulse Length, Duty Cycle or Frequency Inputs for use as command and/or feedback
- Up to 10 Digital Inputs for use as Deadman Switch, Limit Switch, Emergency stop or user inputs
- Inputs for up to 2 Quadrature Encoders
- 4 general purpose 24V, 1.5A output for brake release or accessories
- Built-in Basic-like scripting language. Execution speed up to 100000 lines per second
- Selectable min, max, center and dead band in Pulse and Analog modes
- Selectable exponentiation factors for each command inputs
- Trigger action if Analog, Pulse or Hall counter capture are outside user selectable range (soft limit switches)
- Open loop speed control operation
- Closed loop speed, position and/or torque control
- Closed loop position control with encoder, hall sensors, analog or pulse/frequency feedback
- Cascaded Speed, Position, Torque PID loops
- High-Performance 16kHz Current Control loop
- Automatic Tuning of Torque, Speed and Position loops
- Automatic Field Weakening for maximum Speed & Torque
- Automatic Motor Characterization
- Advanced performance optimization algorithms (Anti-cogging, notch filter, ...)
- Built-in Battery Voltage and Temperature sensors
- Optional backup power input for powering safely the controller if the main motor batteries are discharged
- Power Control wire for turning On or Off the controller from external microcomputer or switch
- No consumption by output stage when motors stopped
- Regulated 5V output for powering RC radio, RF Modem, sensors or microcomputer
- Separate Programmable acceleration and deceleration for each motor
- Ultra-efficient 2.5 mOhm ON resistance MOSFETs (1.25 mOhm on Single Channel)
- Stall detection and selectable triggered action if Amps is outside user-selected range
- Short circuit protection
- Overvoltage and Undervoltage protection
- Watchdog for automatic motor shutdown in case of command loss
- Overtemperature protection
- Diagnostic LED
- Efficient heat sinking. Operates without a fan in most applications.
- IP40 case protection rating
- Power wiring 0.25" Faston tabs
- 5.5" (139.7mm) L, 5.5" W (139.7mm), 1.0" (25mm) H
- -40oC to +85o C operating environment
- 1 lbs (500g)
- Easy configuration, tuning and monitory using provided PC utility
- Field upgradeable software for installing latest features via the Internet

## Orderable Product References

Reference	Number of Channels	Amps/Channel	Volts	Ethernet
FBLG2360T	2	60	60	No
FBLG2360TS	1	120	60	No
FBLG2360TP	2	60	60	Profinet-TCP/IP
FBLG2360TPS	1	120	60	Profinet-TCP/IP
FBLG2360TI	2	60	60	EthernetIP
FBLG2360TIS	1	120	60	EthernetIP
FBLG2360TC	2	60	60	EtherCAT
FBLG2360TCS	1	120	60	EtherCAT

## Important Safety Disclaimer

Dangerous uncontrolled motor runaway condition can occur for a number of reasons, including, but not limited to: command or feedback wiring failure, configuration error, faulty firmware, errors in user script or user program, or controller hardware failure.

The user must assume that such failures can occur and must make his/her system safe in all conditions. Roboteq will not be liable in case of damage or injury as a result of product misuse or failure.

## Power Terminals Identifications and Connection

Power connections are made by means of faston tabs located at the back of the controller.

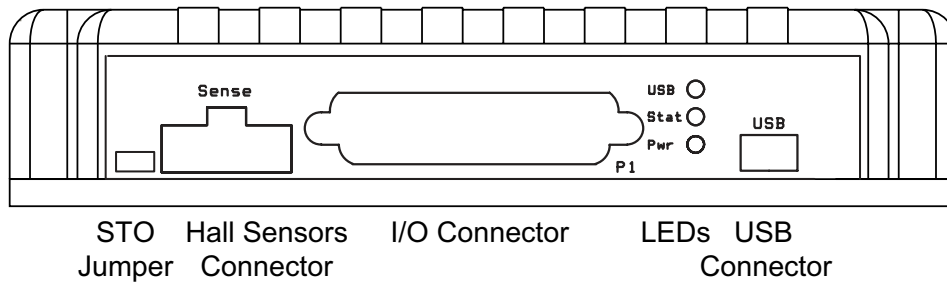

FIGURE 1. FBLG2360T front view

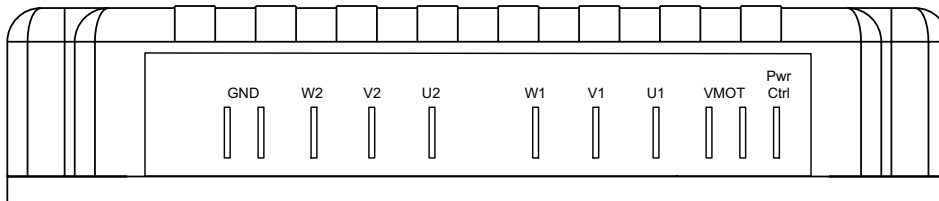

FIGURE 2. FBLG2360T rear view

The diagram below shows how to wire the controller and how to turn power On and Off.

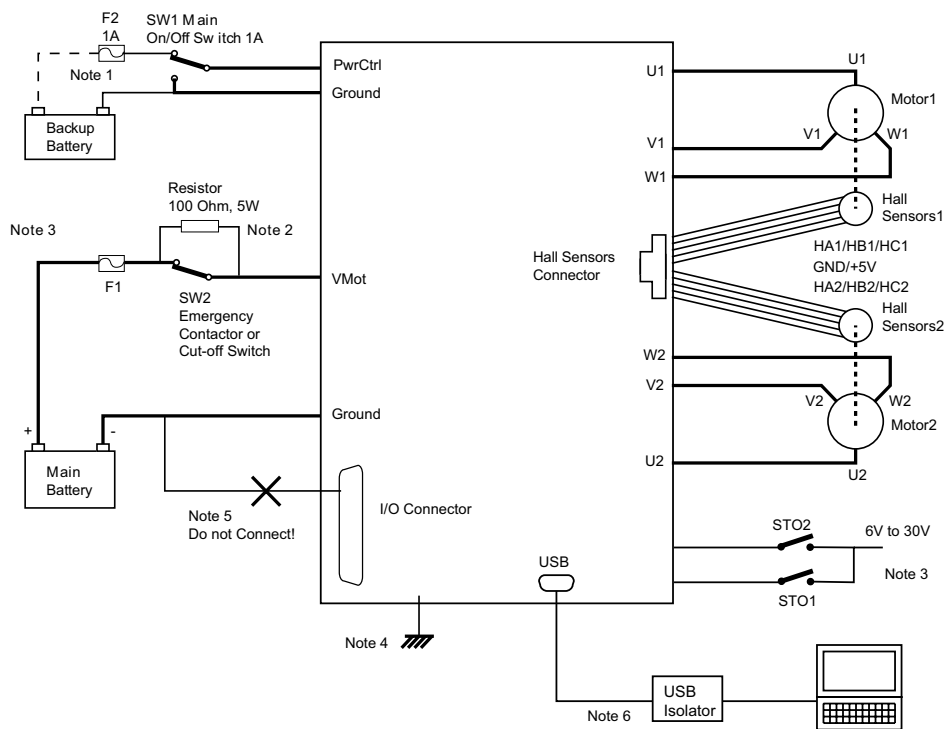

FIGURE 3. Powering the controller. Thick lines identify MANDATORY connections

## Important Warning

**Carefully follow the wiring instructions provided in the Power Connection section of the User Manual. The information on this datasheet is only a summary.**

### Mandatory Connections

It is imperative that the controller is connected as shown in the above diagram in order to ensure a safe and trouble-free operation. All connections shown as thick black lines are mandatory. The controller must be powered On/Off using switch SW1 on the PwrCtrl tab. Use a suitable high-current fuse F1 as a safety measure to prevent damage to the wiring in case of major controller malfunction.

### Emergency Switch or Contactor

The battery must be connected in permanence to the controller's VMot tabs via a high-power emergency switch or contactor SW2 as additional safety measure. The user must be able to deactivate the switch or contactor at any time, independently of the controller state

## Power On/Off Switch

The **controller must be powered On/Off using switch SW1** on the Power Control pin.

Note 1: To ensure motor operation with weak or discharged batteries, connect a second battery to the Power Control pin via the SW1 switch. This will keep the controller alive and responding even if no voltage is present on the Vmot terminal.

## Precharge Resistor

The controller has 2350uF of internal capacitance which will cause a short duration but important current inrush the moment power is applied.

Note 2: If there is a concern that this current can overload the power supply or the contactor, insert a precharge resistors as shown in the figure. For precharging to take place, the controller must be turned off by grounding the Power Control pin.

## Enable Safe Torque Off

Note 3: When STO is enabled (STO jumper removed), the Motor will be prevented from running until its STO inputs are both connected to a voltage of 6V or higher. If one or both STO lines are floated or grounded, the drive will be ON and able to communicate but the motor will not be driven. See details further down in this datasheet and in the User Manual.

## Regeneration Protection and Braking

During rapid deceleration, the kinetic energy will cause regeneration current flow out of the motor, back to the power source. When using a battery, the current will recharge the battery and create a dynamic braking effect. When a power supply is used, current will not be able to flow back to the source. Without that return path, the regeneration will cause voltage to rise up to dangerous level for the electronics.

## Connection to Chassis

Note 4: For improved EMI immunity and reduce emissions, it is recommended to connect the controller's bottom plate to the system's chassis. Note that the integrated controller's ground is not DC electrically connected the plate. There is, however, a capacitor between the controller's ground and the bottom plate, and therefore AC conductivity.

## Avoid Alternate Ground Paths

Note 5: Beware not to create a path from the ground pins on the I/O connector and the battery minus terminal. It is highly recommended to avoid this connection as current could circulate in the signals ground, which could create noise on the low power signals. If the main ground power terminal is loose or disconnected, very high current may circulate in the signals ground wire and damage it.

## Precautions When Connecting PC via USB

Note 6: Always use an USB isolator to protect the drive and the PC against possible electrical damage. When using a portable PC, operate it from battery to avoid accidental return ground path via the charger.

## Electrostatic Discharge Protection

In accordance with IEC 61000-6-4, Roboteq Motor Controllers are designed to withstand ESD up to 4kV touch and 8kV air gap. This protection is implemented without any additional external connections required.

Some specifications, such as EN12895, require a higher level of protection. To maximize ESD protection, up to 8kV touch and 15kV air gap, you may connect the metallic heatsink of the controller to your battery negative terminal.

---

## Single Channel Wiring

On the Single Channel FBLG2360TS, the each of the motor wire must be connected to both output tabs of the same letter as shown in the figure below. Use the Encoders and/or Hall sensors of Channel 1 for operation.

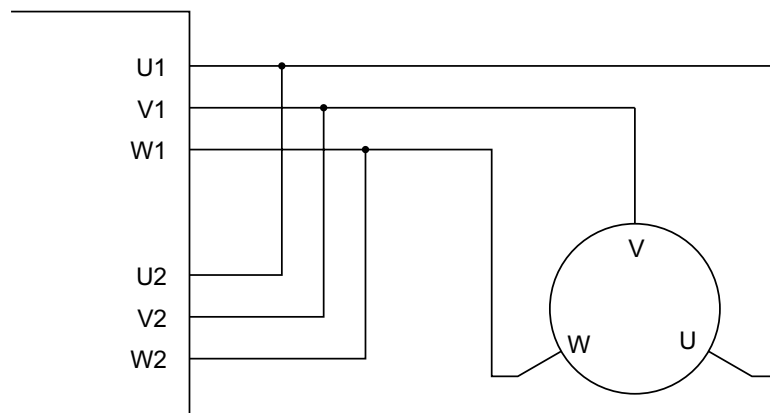

FIGURE 4. Single Channel wiring diagram

---

## Important Warning

**This wiring must be done only on the single channel version of the controller. Paralleling the wires on a dual channel product will cause permanent damage. Verify that your controller is an -S model before you wire in this manner.**

---

## Controller Mounting

During motor operation, the controller will generate heat that must be evacuated. The published amps rating can only be fully achieved if adequate cooling is provided. Good conduction cooling can be achieved by having the bottom surface of the case making direct contact with a metallic surface (chassis, cabinet). The mounting has to be like that, so that the thermal-safety limits are not exceeded.

### Hall Sensors Connection

Connection to the Hall Sensors is done using a special connector on the front side of the controller. The Hall sensor connector is a 10-pin Molex Microfit 3.0, ref. 43025-1000. Pin assignment is in the table below.

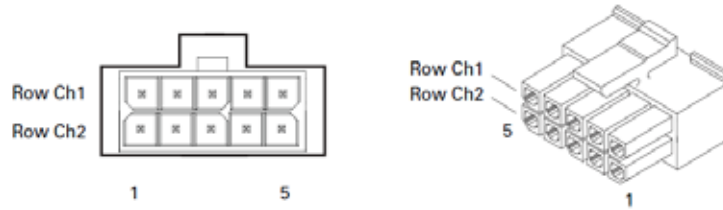

FIGURE 5. Hall Sensors connector

TABLE 1.

Pin Number	1	2	3	4	5
Row Ch1	5V	Hall1 C	Hall1 B	Hall1 A	Ground
Row Ch2	5V	Hall2 C	Hall2 B	Hall2 A	Ground

### Hall Sensor vs Motor Output sequencing

The controller requires the Hall sensors inside the motor to be 120 degrees apart. The controller's 3-phase bridge will activate each of the motor winding according to the sequence shown in the figure below.

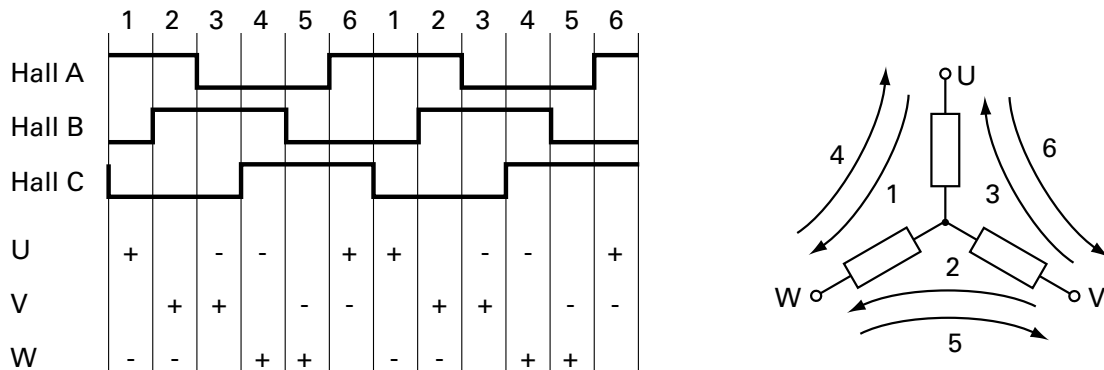

FIGURE 6. Hall Sensors sequence

### Connection to SPI Absolute Encoder

In Sinusoidal Mode, the controller can use motors equipped with absolute angle sensors with SPI interface.

When enabled, the SPI signals are found on the 10-pin Molex connector that is otherwise used for the Hall Sensors. The controller issues a clock and select signal. When two motors are used, these two signals must be connected to both sensors. Serial data from each sensor is captured on separate input pins.

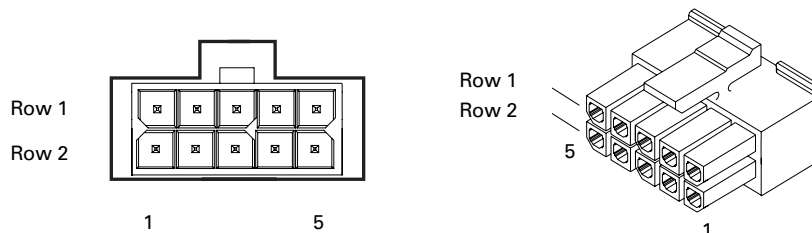

FIGURE 7. Hall Sensor connector used for SPI encoders

TABLE 2.

Pin Number	1	2	3	4	5
Row 1	5V	NC	NC	Sel	GND
Row 2	5V	Clock	Data 2	Data 1	GND

### Connection to SSI Absolute Encoder

In Sinusoidal Mode, the controller can use motors equipped with absolute angle sensors with SSI interface. When enabled, the SSI signals are found on the 10-pin Molex connector that is otherwise used for the Hall Sensors. The controller issues a differential clock signal and expects a 12-bit differential data signal from the encoder. When two motors are used, the clock signals must be connected to both sensors. Serial data from each sensor is captured on separate input pins.

TABLE 3.

Pin Number	1	2	3	4	5
Row 1	5V	CLK –	Data 2 –	Data 1 –	GND
Row 2	5V	Clock +	Data 2 +	Data 1 +	GND

### Connection to Analog Sin/Cos Absolute Encoder

The FBLG2360T has 4 high-speed analog inputs that can be used to capture absolute angle position from resolvers or magnetic sensors with sin/cos voltage outputs. The signal must be 0-5V max with the 0 at 2.500V. The table below shows the signals assignment on the 25-pin connector.

TABLE 4.

Signal	Pin Number	Pin Name
Sin1	9	ASIN1
Cos1	10	ACOS1
Sin2	24	ANA7/ASIN2
Cos2	12	ANA8/ACOS2



### Connecting Resolver

Resolver wiring is similar to a Sin/Cos sensor with the addition of an excitation signal. Diagram below shows the necessary connections.

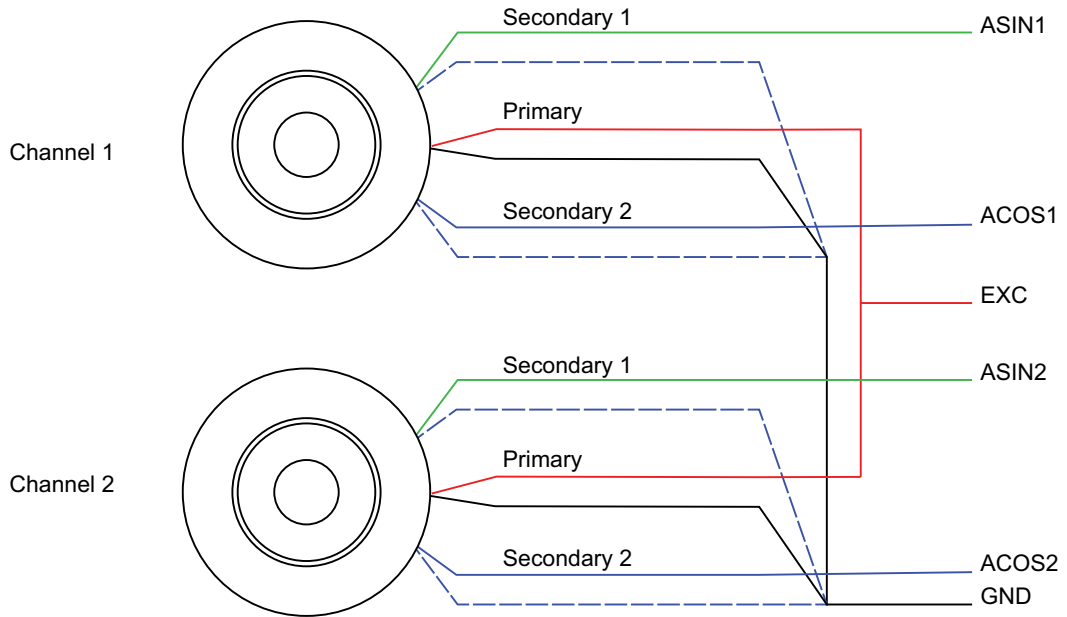

FIGURE 8. Resolver wiring

The table below shows the resolver signals assignment on the 25-pin connector.

TABLE 5.

Signal	Pin Number	Pin Name
Sin1	9	ASIN1
Cos1	10	ACOS1
Sin2	24	ANA7/ASIN2
Cos2	12	ANA8/ACOS2
Exc	17	ANA4/EXC
GND	1-5 or 13	GND

### Commands and I/O Connections

Connection to RC Radio, Microcomputer, Joystick and other low current sensors and actuators is done via the DB25 connector. The functions of many pins vary depending on controller model and user configuration. Pin assignment is found in the table below.

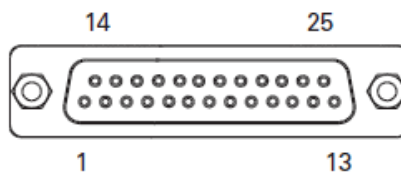

FIGURE 9. Main Connector pin locations

TABLE 6.

Connector Pin	Power	Dout	STO	Com	Pulse	Ana	Dinput	Enc
1	GND							
14	5VOut							
2				RS TxD				
15			STO1 (1)		RC1 (3)	ANA1	DIN1	
3				RS RxD				
16			STO2 (1)		RC2 (3)	ANA2	DIN2	
4					RC3	ANA3	DIN3	
17					RC4	ANA4/EXC (2)	DIN4	
5	GND							
18		DOUT1						
6		DOUT2						
19		DOUT3						
7		DOUT4						
20				CANH				
8				CANL				
21					RC5	ANA5	DIN5	ENC2A
9						ASIN1	DIN9	
22					RC6	ANA6	DIN6	ENC2B
10						ACOS1	DIN10	
23				485 +				
11				485 -				
24					RC7	ANA7/ASIN2	DIN7	ENC1A
12					RC8	ANA8/ACOS2	DIN8	ENC1B
25	5VOut							
13	GND							

Note 1: STO jumper must be removed for STO signals to be active. See STO section for details.

Note 2: Input 4 has a large capacitance which may degrade the Pulse signal. Prefer any of the other pulse inputs.

Note 3: Do not use for multiPWM input signals.

## Enabling Analog Commands

For safety reasons, the Analog command mode is disabled by default. To enable the Analog mode, use the PC utility and set Analog in Command Priority 2 or 3 (leave Serial as priority 1). Note that by default the additional securities are enabled and will prevent the motor from starting unless the potentiometer is centered, or if the voltage is below 0.25V or above 4.75V. Use the PC utility to enable and assign analog inputs.

## USB Communication

Use USB only for configuration, monitoring and troubleshooting. USB is not a reliable communication method when used in a electrically noisy environments and communication will not always recover after it is lost without unplugging and replugging the connector, or restarting the controller. Always prefer RS232 communication when interfacing to a computer.

## Important Warning

**Always use an USB isolator to protect the drive and the PC against possible electrical damage. When using a portable PC, operate it from battery to avoid accidental return ground path via the charger.**

## CAN Communication

CAN is the FBLG2360T's primary and recommended communication interface. Up to 127 drives can be networked on a low cost twisted pair network up to 1000m long and at speeds up to 1Mbit/s. Roboteq support four CAN protocols:

- CANOpen for interoperability with other vendor's DS301 and DS402 compliant devices
- RoboCAN, a simple and effective peer to peer meshed network protocol
- MiniCAN, a simplified subset of CANOpen PDOs
- Raw CAN, a low-level system used with scripting for constructing and parsing CAN frames to handle any protocols

TABLE 7. CANOpen Communications Specification

Feature	Value
Motion Network type	CAN, CANOpen
CANOpen Standards Support	DS301, DS402
Operating Modes	cyclic sync torque, cyclic sync velocity, cyclic sync position, profile position, profile velocity, profile torque modes, homing
Process Data Objects (PDO)	Cyclic sync and free run modes. Cyclic messages can be set for 20 objects on 4 maps

## RS485 Communication

RS485 is an industry standard for defining serial communication. Due to its balanced signalling, RS485 is effective over distances, even if other electrical signals are present. Its stability makes it well suited to connect multiple receivers to a single network.

You can operate RS485 in half-duplex mode and it is well suited for use with the Modbus protocol. On the 25-pin connector, RS485+ and RS485- pins are present.

## Ethernet, EtherCAT, Profinet and EthernetIP Communication

The FBL2360 is available in several versions with different Ethernet-based communication protocols and fieldbuses.

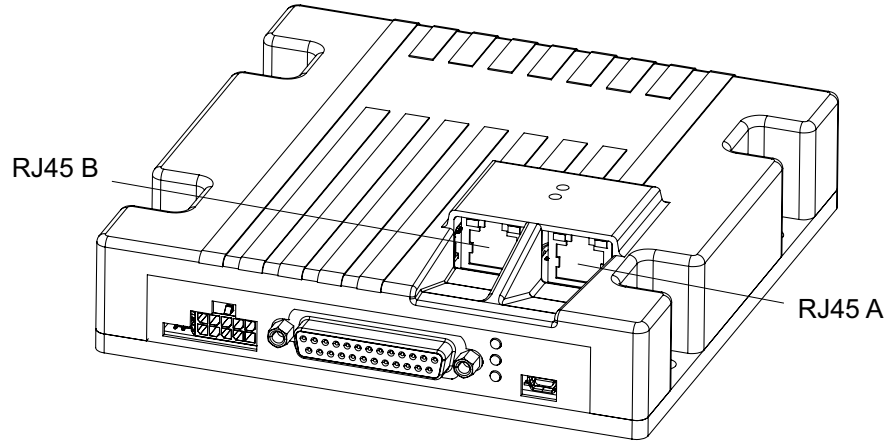

FIGURE 10. Ethernet Ports location

The FBLG2360TC is a version that supports the EtherCAT interface. EtherCAT is an Ethernet-based communication protocol for fast and precise synchronization in multi-drive, multi-axis systems. The controller supports CANOpen over EtherCAT (CoE), meaning that it shares the CANOpen DS402 object directory and operating modes. Connection to the EtherCAT bus is done using two RJ45 connectors. See the EtherCAT/CAN Networking Manual for details.

The FBLG2360TP is a version that supports the Standard Profinet fieldbus. Profinet is an Ethernet-based communication protocol developed by Siemens and that can be used to interface to PLCs, typically in factory automation applications. See the Profinet Communication Manual for details. This version also supports all the controller's serial command set over a TCP/IP connection. Modbus TCP protocols are also supported.

The FBLG2360TI is a version that supports the Standard EthernetIP fieldbus. EthernetIP is an Ethernet-based communication protocol commonly used to interface with Allen-Bradley PLCs. See the EthernetIP Communication Manual for details.

## Status LED Flashing Patterns

After the controller is powered on, the Power LED will turn on, indicating that the controller is On. The Status LED will be flashing at a two-second interval. The flashing pattern and color provide operating or exception status information.

	Idle - Waiting for Command
	RS232/USB Mode
	RC Pulse Mode
	Analog Mode

FIGURE 11. Normal Operation Flashing Patterns

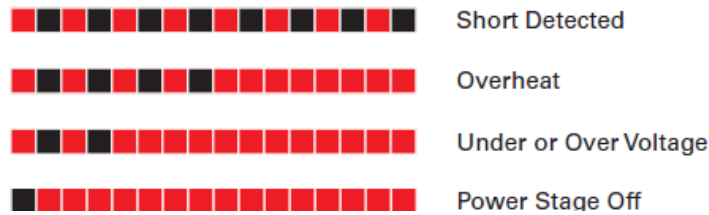

FIGURE 12. Exception or Fault Flashing Patterns

Additional status information may be obtained by monitoring the controller with the PC utility. The communication LED gives status information on the CAN Bus and USB.

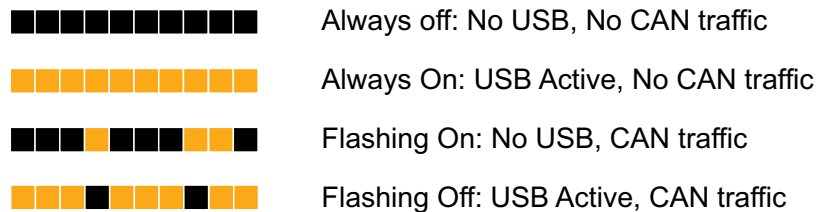

FIGURE 13. Exception or Fault Flashing Patterns

## Battery Backed Clock and Variables

The controller includes a real-time clock/calendar and RAM storage for user variables. Both the clock and the RAM storage require a battery to continue running and for the stored data not to be lost while the controller is powered down. The battery is not installed by Roboteq. Users who wish to use the clock and/or battery backed RAM variables must install a CR1225 or equivalent battery. The battery socket can be reached by removing the screws that are holding the cover. Lift the cover to reach the board and insert a 3V, 12.5mm coin-style battery.

## Safe Torque Off - STO (Certification Pending)

Safe Torque Off is a safe method for switching controller in a state where no torque is generated, regardless whether the controller is operating normally or is faulty. When STO is enabled, two digital inputs, DIN1 and DIN2 are remapped as STO1 and STO2. The inputs are redundant and both must have a 6V to 30V signal present at the same time in order for the Power MOSFETs to be energized. The controller will perform a self-check of the STO circuit at every power on and every time the STO inputs go from any state to both high. Once the STO hardware is verified to work, the controller will safely allow the motors to be energized. If either input is below 1V, the controller's outputs will be disabled. The STO circuit is verified and validated and can therefore be trusted instead of external relays. See [STO Manual](#) for more information and maintenance instructions.

By factory default STO functionality is disabled. It must be enabled by removing the jumper located on the front side of the controller.

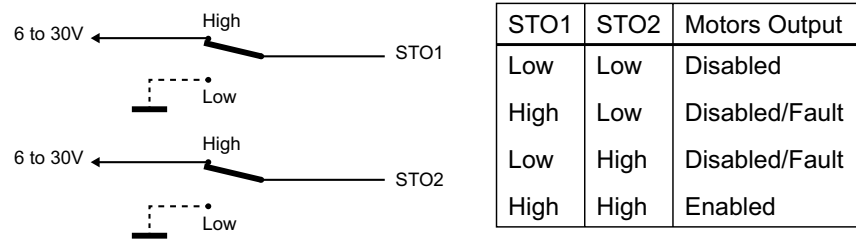

FIGURE 14. STO input levels effects on controller output

The STO function is compliant to:

- IEC 61800-5-2:2017, SIL 3
- IEC 61508:2010, SIL 3
- IEC 62061:2015, SIL 3
- ISO 13849-1:2015, Category 3 Performance Level e

## Important Warning

**Activating STO causes the motor to float and stop generating torque. The motor will not be actively stopped and will slow down only through the system’s friction. In Mobile Robot applications, the robot may keep moving for several meters. To be safe, additional braking should be provided by applying a mechanical brake, or braking electrically by shorting the motor’s winding using Roboteq’s SBSxxxx series Safety Electric Brake Switches.**

## Electrical Specifications

### Absolute Maximum Values

The values in the table below should never be exceeded, permanent damage to the controller may result.

TABLE 8.

Parameter	Measure point	Min	Typ	Max	Units
Battery Leads Voltage	Ground to Vmot			65 (1)	Volts
Reverse Voltage on Battery Leads	Ground to Vmot	-1			Volts
Power Control Voltage	Ground to PwrCtrl wire			65 (1)	Volts
Motor Leads Voltage	Ground to U, V, W wires			60 (1)	Volts
Digital Output Voltage	Ground to Output pins			30	Volts
Analog and Digital Inputs Voltage	Ground to any signal pin on DB25 & Hall inputs			30	Volts
RS232 I/O pins Voltage	External voltage applied to Rx pins			30 (2)	Volts
Case Temperature	Case	-40		85	°C
Humidity	Case			100 (3)	%
Note: Only PELV/SELV voltages shall be used					
Note 1: Can be even higher because of regeneration voltage. Never inject a DC voltage from a battery or other fixed source					
Note 2: No voltage must be applied on Tx pin					
Note 3: Non condensing					

### Power Stage Electrical Specifications (at 25°C ambient)

TABLE 8.

Parameter	Measure point	Model	Min	Typ	Max	Units
Input Voltage	Ground to Vmot	All	0 (1)		60	Volts
Input continuous Max Current	Power source current	All			80	Amps
Output Voltage	Ground to U, V, W wires	All	0 (1)		60 (2)	Volts
Power Control Voltage	Ground to Power Control wire	All	0 (1)		65	Volts
Minimum Operating Voltage	VBat or PwrCtrl wires	All	12 (3)			Volts
Over Voltage protection range	Ground to Vmot	All	5	60 (4)	63	Volts
Under Voltage protection range	Ground to Vmot	All	0	5 (4)	63	Volts
Input Capacitance	Ground to Vmot	All		2350		uF
Idle Current Consumption	Vmot or PwrCtrl wires	All	50	100 (5)	150	mA
ON Resistance (Excluding wire resistance)	Vmot to U, V or W. Ground to U, V or W	FBLG2360T		2.5		mOhm
		FBLG2360TS		1.25		mOhm
Max Current for 30s	Motor current	FBLG2360T			60	Amps
		FBLG2360TS			120	Amps
Continuous Max Current per channel	Motor current	FBLG2360T			40 (6)	Amps
		FBLG2360TS			80 (6)	Amps

TABLE 9.

Parameter	Measure point	Model	Min	Typ	Max	Units
Current Limit range	Motor current	FBLG2360T	10	50 (7)	60	Amps
		FBLG2360TS	20	100 (7)	120	Amps
Stall Detection Amps range	Motor current	FBLG2360T	10	60 (7)	60	Amps
		FBLG2360TS	20	120 (7)	120	Amps
Stall Detection timeout range	Motor current	All	1	500 (8)	65000	msec
Short Circuit Detection threshold (9)	Between Motor wires or Between Motor wires and ground or Between Motor wires and Vmot	FBLG2360T			120(10)	Amps
		FBLG2360TS			220 (10)	Amps
Motor Acceleration/ Deceleration range	Motor Output	All	100	500(11)	65000	msec
Power cable thickness	Power input and output	All		8		AWG

Note 1: Negative voltage will cause a large surge current. Protection fuse needed if battery polarity inversion is possible  
 Note 2: Can be even higher because of regeneration voltage. Never inject a DC voltage from a battery or other fixed source  
 Note 3: Minimum voltage must be present on VBat or Power Control wire  
 Note 4: Factory default value. Adjustable in 0.1V increments  
 Note 5: Current consumption is lower when higher voltage is applied to the controller's VBat or PwrCtrl wires  
 Note 6: Estimate. Limited by case temperature. Current may be higher with better cooling  
 Note 7: Factory default value. Adjustable in 0.1A increments  
 Note 8: Factory default value. Time in ms that Stall current must be exceeded for detection  
 Note 9: Controller will stop until restarted in case of short circuit detection" change with "Controller will stop until zero command given in case of short circuit detection  
 Note 10: Approximate value  
 Note 11: Factory default value. Time in ms for power to go from 0 to 100%

## Command, I/O and Sensor Signals Specifications

TABLE 9.

Parameter	Measure point	Min	Typ	Max	Units
Main 5V Output Voltage	Ground to 5V pins on	4.6	4.9	5.2	Volts
5V Output Current	5V pins on RJ45 and DSub15			200 (1)	mA
Digital Output Voltage	Ground to Output pins			30	Volts
Output On resistance	Output pin to ground		0.25	0.5	Ohm
Output Short circuit threshold	Output pin	1.7		3.5	Amps
Digital Output Current	Output pins, sink current			1.5	Amps
Input Impedances (except DIN11-19)	AIN/DIN Input to Ground		53		kOhm
Digital Input 0 Level	Ground to Input pins	-1		1	Volts
Digital Input 1 Level	Ground to Input pins	3.8		30	Volts
Analog Input Range	Ground to Input pins	0		5.1	Volts
Analog Input Precision	Ground to Input pins		0.5		%



TABLE 9.

Parameter	Measure point	Min	Typ	Max	Units
Analog Input Resolution	Ground to Input pins		1		mV
Encoder Frequency				500	kHz
Pulse durations	Pulse inputs	20000		10	us
Pulse repeat rate	Pulse inputs	50		250	Hz
Pulse Capture Resolution	Pulse inputs		1		us
Min Pulse On/Off Duration	Pulse inputs		25		us
Frequency Capture	Pulse inputs	100		1000	Hz
Note 1: Sum of all 5VOut outputs					

## Operating & Timing Specifications

TABLE 10.

Parameter	Measure Point	Min	Typ	Max	Units
Command Latency	Command to output change	0	0.5	1	ms
Max PWM duty cycle	Motor Output			93.8	%
Closed Loop update rate	Internal		1000 (1)		Hz
Current Loop update rate	Internal		16000		Hz
RS232 baud rate	Rx & Tx pins		115200 (2)		Bits/s
RS232 Watchdog timeout	Rx pin	1 (3)		65000	ms
Note 1: Applies to closed loop speed and closed loop position modes only					
Note 2: 115200, 8-bit, no parity, 1 stop bit, no flow control					
Note 3: May be disabled with value 0					

## Motor Characteristics Requirement for FOC current control

For proper FOC current control and motor operation under sinusoidal commutation, it is necessary for the motor to meet a minimum load inductance, minimum load L/R and maximum electric operating speed requirements. The minimum required inductance is necessary in order to ensure low Total Harmonic Distortion (THD) of the motor current. Furthermore, to achieve proper current response and stability, the controller's current loop sampling rate will limit the minimum permissible motor time constant  $\tau=L/R$  and the maximum operating electric speed.

TABLE 11.

Parameter	Input DC Voltage (V)	Value	Units
Minimum load phase inductance (1)	12	25	uH
	24	40	uH
	48	60	uH
	60	80	uH
Minimum load inductance/resistance ratio (1)	0 - 60	0.063	msec
Maximum operating electric speed (2)	0 - 60	96000	RPM

Note 1: Star connected three phase load considered. In case the motor phase inductance does not fulfill the above requirements (minimum phase inductance and inductance/resistance ratio) an external AC inductor with proper inductance value is recommended to be added.

Note 2: Maximum rotor speed is calculated from the maximum operating electric speed and pole pairs. For example, in a motor with 4 pole pairs the maximum operating rotor speed is  $96000/4 = 24000$  rpm

## Scripting

TABLE 12.

Parameter	Measure Point	Min	Typ	Max	Units
Scripting Flash Memory	Internal		32K		Bytes
Max Basic Language programs	Internal	2000		3000	Lines
Integer Variables	Internal		4096		Words (1)
Boolean Variables	Internal		8192		Symbols
Execution Speed	Internal	50 000	100 000		Lines/s
Note 1: 32-bit words					

## Thermal Specifications

TABLE 13.

Parameter	Measure Point	Min	Typ	Max	Units
Case Temperature	Case	-40		85 (1)	°C
Thermal Protection range	Case	80		90 (2)	°C
Power Dissipation	Case			70	Watts
Thermal resistance	Power MOSFETs to case			0.6	°C/W
Humidity	Case			95	%
Ambient temperature	Ambient			40	°C
Pollution Degree	-				
Fast fuse to install (3)	FBLG2360T (4)		2 x 60		Amps
	FBLG2360TS (4)		2 x 60		Amps
Overload motor protection	-	Check note 5			

Note 1: Thermal protection will protect the controller power

Note 2: Max allowed power out starts lowering at minimum of range, down to 0 at max of range

Note 3: There are two power terminal tabs. Fuse should be installed in both of them for safety

Note 4: In dual channel controller, for operating only one channel install 60A fuse and for operating both channels 2 x 60A fuse should be installed. Power source must be capable to blow the fuse instantly in case of short circuit

Note 5: Current limiting mechanism available through firmware. External overload motor protection can be used if required (provided by user)

### STO Specifications

TABLE 14.

Parameter	Measure Point	Min	Typ	Max	Units
STO Input High Level	Ground to STO input pin	6		30 (1)	Volts
STO Input Low Level	Ground to STO input pin	0		1	Volts
STO Response Time	Input to output change			5	msec
STO Operating temperature		-20		55	°C
STO Storage temperature		-20		70	°C
Humidity		5		95	%
IP degree				IP40	
Operating Altitude				2000	m
Cable Length				2	m
EMC Immunity	According to IEC 61800-3 and IEC 61800-5-2 Annex E				
CE Declaration	Available at <a href="http://www.roboteq.com">www.roboteq.com</a>				

### Mounting and Thermal Consideration

### Mechanical Specifications

TABLE 15.

Parameter	Measure Point	Min	Typ	Max	Units
Weight	Board		500 (1)		g (lbs)
Power Connectors width	Terminal tab		0.25		Inches

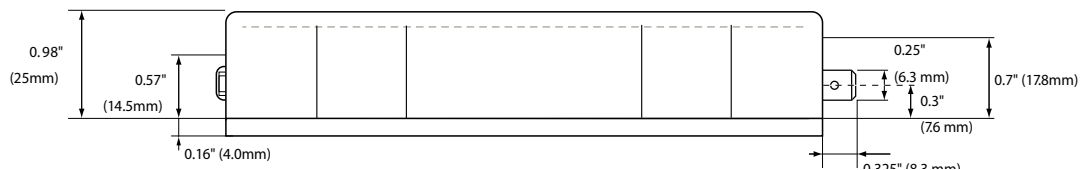

FIGURE 15. FBLG2360T side view and dimensions

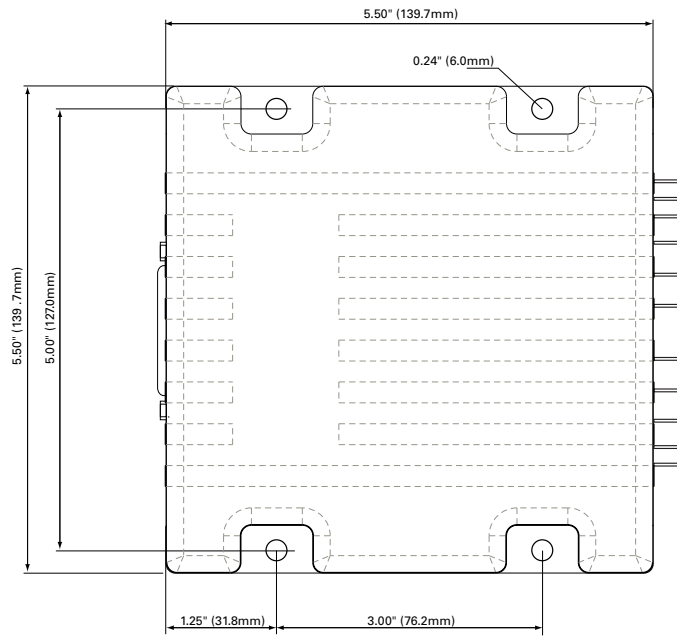

FIGURE 15. FBLG2360T top view and dimensions Mechanical Specifications

**Revision history**

<b>Revision</b>	<b>Date</b>	<b>Additions/Changes</b>
1.1	September 6, 2022	First Official Release
1.0	January 14, 2022	Preliminary Revision Release