

[🏠 \(/xwiki/bin/view/Main/\)](#) ▾ / [Home \(/xwiki/bin/view/Main/\)](#) ▾  
/ [User Manual for LoRaWAN End Nodes \(/xwiki/bin/view/Main/User%20Manual%20for%20LoRaWAN%20End%20Nodes/\)](#) ▾  
/ [SDI-12-LB -- SDI-12 to LoRaWAN Converter User Manual \(/xwiki/bin/view/Main/User%20Manual%20for%20LoRaWAN%20End%20Nodes/SDI-12-LB%20--%20SDI-12%20to%20LoRaWAN%20Converter%20User%20Manual/\)](#) ▾

# SDI-12-LB -- SDI-12 to LoRaWAN Converter User Manual

Last modified by Xiaoling ([/xwiki/bin/view/XWiki/Xiaoling](#)) on 2023/02/24 09:16

---



## Table of Contents :

- 1. Introduction
  - 1.1 What is SDI-12 to LoRaWAN Converter
  - 1.2 Features
  - 1.3 Specification
  - 1.4 Connect to SDI-12 Sensor
  - 1.5 Sleep mode and working mode
  - 1.6 Button & LEDs
  - 1.7 Pin Mapping
  - 1.8 BLE connection
  - 1.9 Mechanical
- 2. Configure SDI-12 to connect to LoRaWAN network
  - 2.1 How it works

- 2.2 Quick guide to connect to LoRaWAN server (OTAA)
- 2.3 SDI-12 Related Commands
  - 2.3.1 Basic SDI-12 debug command
    - all! -- Get SDI-12 sensor Identification
    - aM!,aMC!, aM1!- aM9!, aMC1!- aMC9!
    - aC!, aCC!, aC1!- aC9!, aCC1!- aCC9!
    - aR0!- aR9!, aRC0!- aRC9!
  - 2.3.2 Advance SDI-12 Debug command
  - 2.3.3 Convert ASCII to String
  - 2.3.4 Define periodically SDI-12 commands and uplink.
- 2.4 Uplink Payload
  - 2.4.1 Device Payload, FPORT=5
  - 2.4.2 Uplink Payload, FPORT=2
  - 2.4.3 Battery Info
  - 2.4.4 Interrupt Pin
  - 2.4.5 Payload version
  - 2.4.6 Decode payload in The Things Network
- 2.5 Uplink Interval
- 2.6 Examples To Set SDI commands.
  - 2.6.1 Examples 1
- 2.7 Frequency Plans
- 2.8 Firmware Change Log
- 3. Configure SDI-12-LB via AT Command or LoRaWAN Downlink
  - 3.1 Set Transmit Interval Time
  - 3.2 Set Interrupt Mode
  - 3.3 Set the output time
  - 3.4 Set the all data mode
  - 3.5 Set the splicing payload for uplink
  - 3.6 Set the payload version
- 4. Battery & how to replace
  - 4.1 Battery Type
  - 4.2 Replace Battery
  - 4.3 Power Consumption Analyze
    - 4.3.1 Battery Note
    - 4.3.2 Replace the battery
- 5. Remote Configure device
  - 5.1 Connect via BLE
  - 5.2 AT Command Set
- 6. OTA firmware update
- 7. FAQ
  - 7.1 How to use AT Command to access device?
  - 7.2 How to update firmware via UART port?
  - 7.3 How to change the LoRa Frequency Bands/Region?
- 8. Order Info
- 9. Packing Info

- 10. Support

# 1. Introduction

## 1.1 What is SDI-12 to LoRaWAN Converter

The Dragino **SDI-12-LB** is a **SDI-12 to LoRaWAN Converter** designed for Smart Agriculture solution.

SDI-12 (Serial Digital Interface at 1200 baud) is an asynchronous serial communications ([https://en.wikipedia.org/wiki/Serial\\_communication](https://en.wikipedia.org/wiki/Serial_communication)) protocol for intelligent sensors that monitor environment data. SDI-12 protocol is widely used in Agriculture sensor and Weather Station sensors.

SDI-12-LB has SDI-12 interface and support 12v output to power external SDI-12 sensor. It can get the environment data from SDI-12 sensor and sends out the data via LoRaWAN wireless protocol.

The LoRa wireless technology used in SDI-12-LB allows device to send data and reach extremely long ranges at low data-rates. It provides ultra-long range spread spectrum communication and high interference immunity whilst minimizing current consumption.

SDI-12-LB is powered by **8500mAh Li-SOCI2 battery**, it is designed for long term use up to 5 years.

Each SDI-12-LB is pre-load with a set of unique keys for LoRaWAN registrations, register these keys to local LoRaWAN server and it will auto connect after power on.

### SDI-12-LB in a LoRaWAN Network

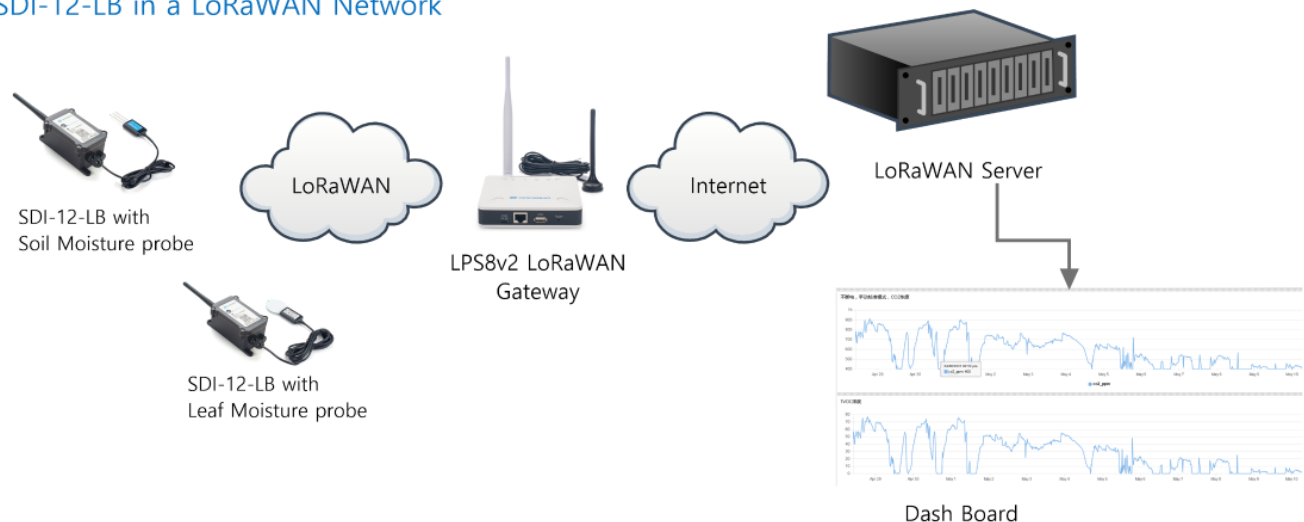

## 1.2 Features

- LoRaWAN 1.0.3 Class A
- Ultra-low power consumption
- Controllable 3.3v, 5v and 12v output to power external sensor
- SDI-12 Protocol to connect to SDI-12 Sensor
- Monitor Battery Level
- Bands: CN470/EU433/KR920/US915/EU868/AS923/AU915/IN865
- Support Bluetooth v5.1 and LoRaWAN remote configure.
- Support wireless OTA update firmware
- Uplink on periodically
- Downlink to change configure
- 8500mAh Battery for long term use

## 1.3 Specification

### Micro Controller:

- MCU: 48Mhz ARM
- Flash: 256KB
- RAM: 64KB

### Common DC Characteristics:

- Supply Voltage: 2.5v ~ 3.6v
- Operating Temperature: -40 ~ 85°C

### LoRa Spec:

- Frequency Range, Band 1 (HF): 862 ~ 1020 Mhz
- Max +22 dBm constant RF output vs.
- RX sensitivity: down to -139 dBm.
- Excellent blocking immunity

### Current Input Measuring :

- Range: 0 ~ 20mA
- Accuracy: 0.02mA
- Resolution: 0.001mA

### Voltage Input Measuring:

- Range: 0 ~ 30v
- Accuracy: 0.02v
- Resolution: 0.001v

### Battery:

- Li/SOCI2 un-chargeable battery
- Capacity: 8500mAh
- Self-Discharge: <1% / Year @ 25°C
- Max continuously current: 130mA
- Max boost current: 2A, 1 second

### Power Consumption

- Sleep Mode: 5uA @ 3.3v
- LoRa Transmit Mode: 125mA @ 20dBm, 82mA @ 14dBm

## 1.4 Connect to SDI-12 Sensor

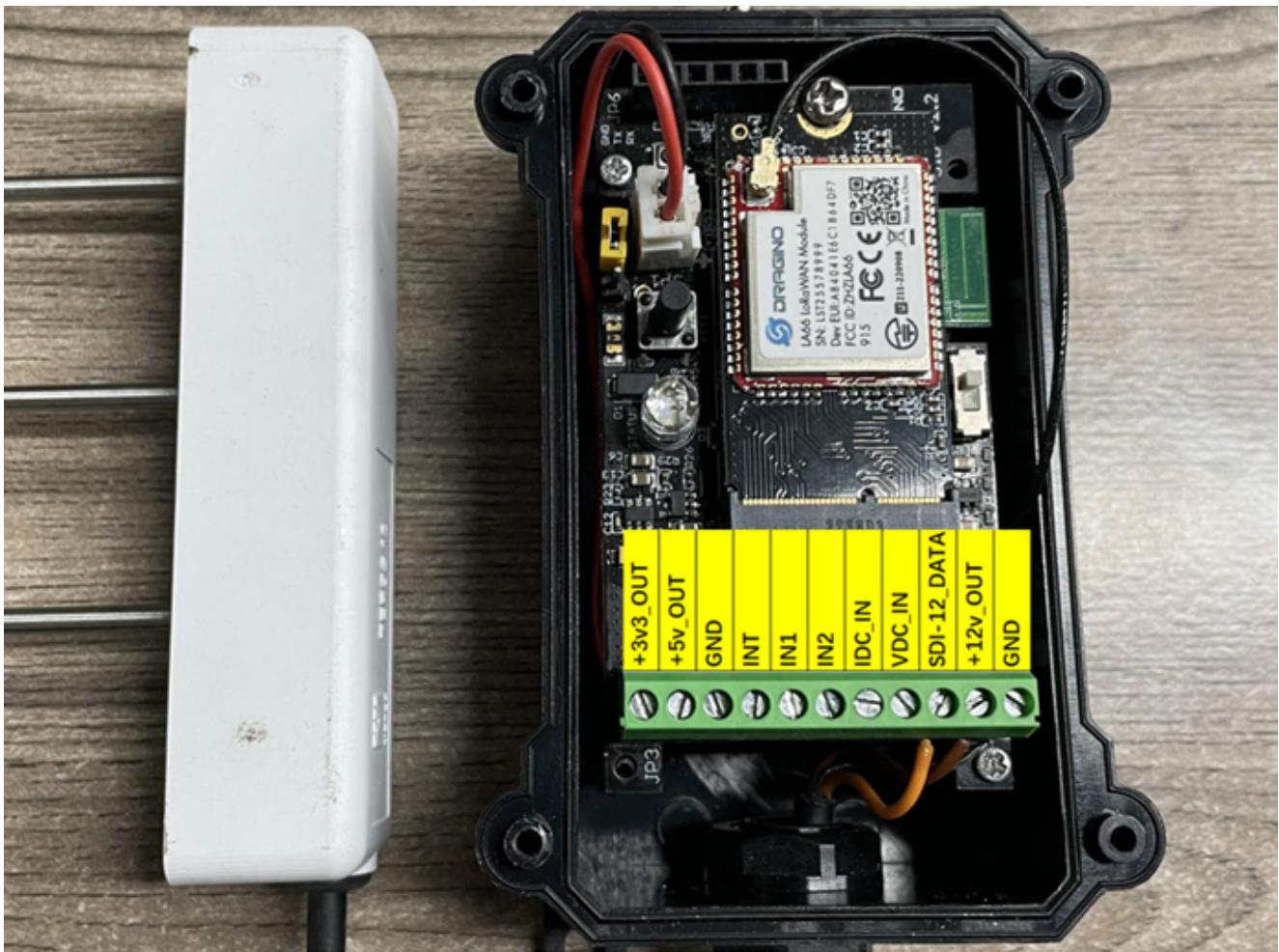

Sensor\_Power<...>+12V  
Sensor\_Ground<...>GND  
Sensor\_Data\_output<...>SDI-12\_DATA

# 1.5 Sleep mode and working mode

**Deep Sleep Mode:** Sensor doesn't have any LoRaWAN activate. This mode is used for storage and shipping to save battery life.

**Working Mode:** In this mode, Sensor will work as LoRaWAN Sensor to Join LoRaWAN network and send out sensor data to server. Between each sampling/tx/rx periodically, sensor will be in IDLE mode), in IDLE mode, sensor has the same power consumption as Deep Sleep mode.

# 1.6 Button & LEDs

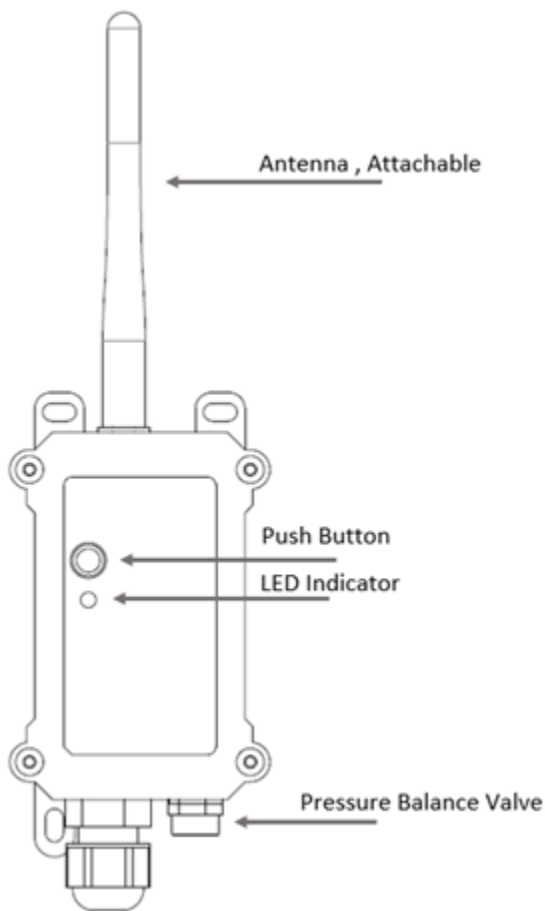

Behavior on ACT	Function	Action
-----------------	----------	--------

Pressing ACT between 1s < time < 3s	Send an uplink	If sensor is already Joined to LoRaWAN network, sensor will send an uplink packet, <b>blue led</b> will blink once. Meanwhile, BLE module will be active and user can connect via BLE to configure device.
Pressing ACT for more than 3s	Active Device	<b>Green led</b> will fast blink 5 times, device will enter <b>OTA mode</b> for 3 seconds. And then start to JOIN LoRaWAN network. <b>Green led</b> will solidly turn on for 5 seconds after joined in network. Once sensor is active, BLE module will be active and user can connect via BLE to configure device, no matter if device join or not join LoRaWAN network.
Fast press ACT 5 times.	Deactivate Device	<b>Red led</b> will solid on for 5 seconds. Means SDI-12-LB is in Deep Sleep Mode.

## 1.7 Pin Mapping





## 1.8 BLE connection

SDI-12-LB support BLE remote configure.

BLE can be used to configure the parameter of sensor or see the console output from sensor. BLE will be only activate on below case:

- Press button to send an uplink
- Press button to active device.
- Device Power on or reset.

If there is no activity connection on BLE in 60 seconds, sensor will shut down BLE module to enter low power mode.

## 1.9 Mechanical

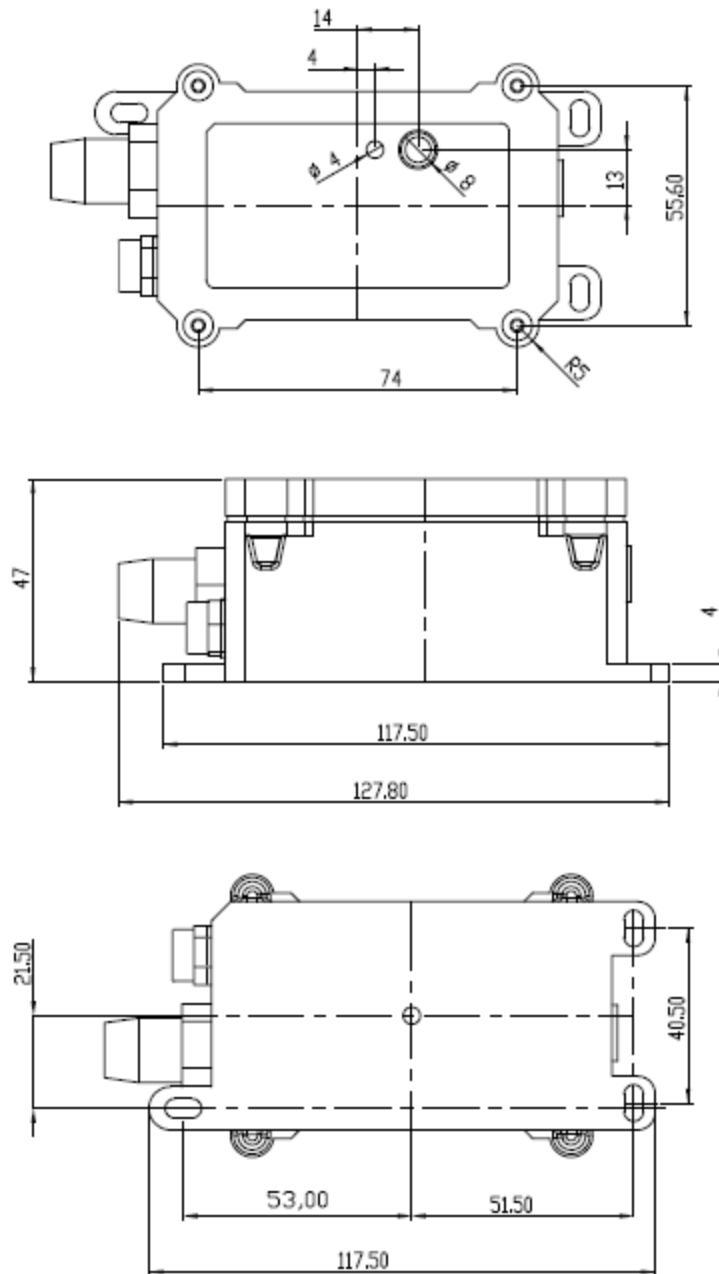

## 2. Configure SDI-12 to connect to LoRaWAN network

### 2.1 How it works

The SDI-12-LB is configured as **LoRaWAN OTAA Class A** mode by default. It has OTAA keys to join LoRaWAN network. To connect a local LoRaWAN network, you need to input the OTAA keys in the LoRaWAN IoT server and activate the SDI-12-LB. It will automatically join the network via OTAA and start to send the sensor value. The default uplink interval is 20 minutes.

## 2.2 Quick guide to connect to LoRaWAN server (OTAA)

Following is an example for how to join the TTN v3 LoRaWAN Network (<https://console.cloud.thethings.network/>) . Below is the network structure; we use the LPS8v2 (<https://www.dragino.com/products/lora-lorawan-gateway/item/228-lps8v2.html>) as a LoRaWAN gateway in this example.

### SDI-12-LB in a LoRaWAN Network

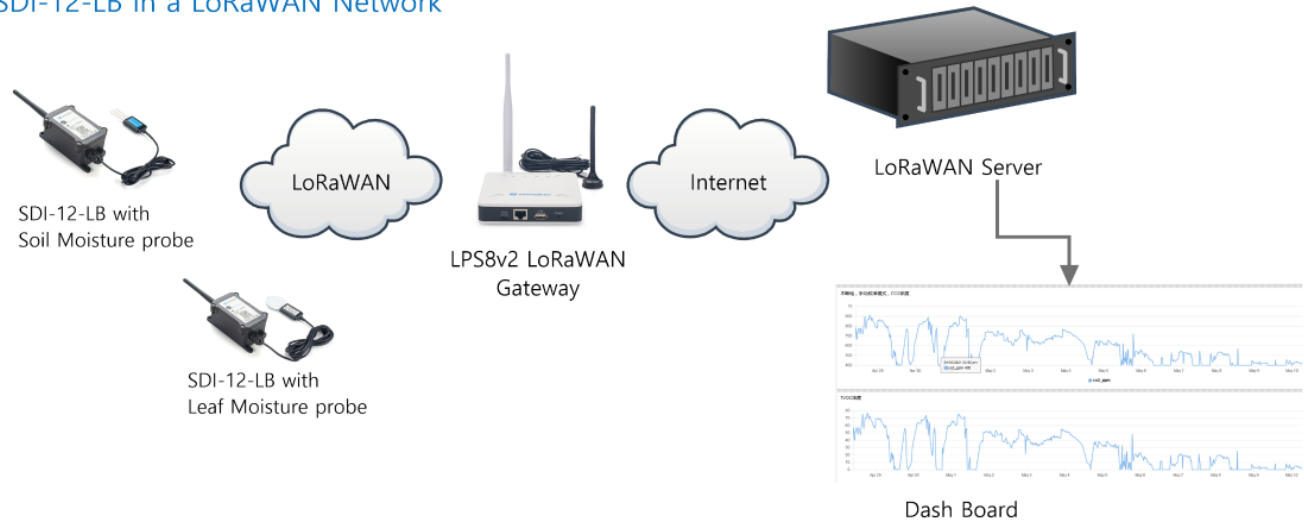

The LPS8V2 is already set to connected to TTN network (<https://console.cloud.thethings.network/>) , so what we need to now is configure the TTN server.

**Step 1:** Create a device in TTN with the OTAA keys from SDI-12-LB.

Each SDI-12-LB is shipped with a sticker with the default device EUI as below:



You can enter this key in the LoRaWAN Server portal. Below is TTN screen shot:

## Register the device

### Register end device

From The LoRaWAN Device Repository [Manually](#)

#### Preparation

##### Activation mode \*

- Over the air activation (OTAA)
- Activation by personalization (ABP)
- Multicast
- Do not configure activation

##### LoRaWAN version ⓘ \*

MAC V1.0.3 | v



##### Network Server address

eu1.cloud.thethings.network

##### Application Server address

eu1.cloud.thethings.network

##### External Join Server ⓘ

Enabled

##### Join Server address

eu1.cloud.thethings.network

Start



## Add APP EUI and DEV EUI

# Register end device

From The LoRaWAN Device Repository [Manually](#)

## 1 Basic settings

End device ID's, Name and Description

## 2 Network layer settings

Frequency plan, regional parameters, end device class and session keys.

## 3 Join settings

Root keys, NetID and kek labels.

End device ID  \*

AppEUI  \*

DevEUI  \*

End device name

End device description

Optional end device description; can also be used to save notes about the end device

[Network layer settings >](#)

## Add APP EUI in the application

# Register end device

From The LoRaWAN Device Repository [Manually](#)



## Basic settings

End device ID's, Name and Description



## Network layer settings

Frequency plan, regional parameters, end device class and session keys.



## Join settings

Root keys, NetID and kek labels.

### Frequency plan \*

Europe 863-870 MHz (SF12 for RX2) |

### LoRaWAN version \*

MAC V1.0.3 |

### Regional Parameters version \*

PHY V1.0.3 REV A |

### LoRaWAN class capabilities

Supports class B

Supports class C

### Advanced settings

[< Basic settings](#)

[Join settings >](#)

## Add APP KEY

## Register end device

From The LoRaWAN Device Repository [Manually](#)

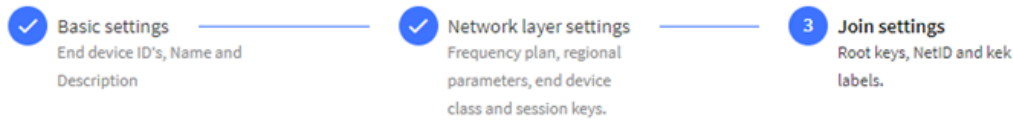

### Root keys

AppKey ⓘ \*

BD 72 1D AC F3 CC AB 67 72 8D 7A F5 4D DF 30 8B ↻

Advanced settings ▾

< Network layer settings

Add end device

### Step 2: Activate on SDI-12-LB

Press the button for 5 seconds to activate the SDI-12-LB.

**Green led** will fast blink 5 times, device will enter **OTA mode** for 3 seconds. And then start to JOIN LoRaWAN network. **Green led** will solidly turn on for 5 seconds after joined in network.

**sdi12-lb**  
ID: sdi12-lb

↑ 1 ↓ n/a \* Last activity 6 seconds ago ⓘ

Overview **Live data** Messaging Location Payload formatters Claiming General settings

Time	Type	Data preview
↓ 16:42:14	Schedule data downlink for t...	DevAddr: 26 0B F3 AA <> Rx1 Delay: 5
↑ 16:42:13	Forward uplink data message	DevAddr: 26 0B F3 AA <> Payload: { BatV: 3.328, EXTI_Trigger: "FALSE", Payver: 1 } 00 00 01 <> FPort: 2 Data rate:
↑ 16:42:13	Successfully processed data _	DevAddr: 26 0B F3 AA <>
↑ 16:42:07	Forward join-accept message	DevAddr: 26 0B F3 AA <>
🔊 16:42:06	Accept join-request	DevAddr: 26 0B F3 AA <>

## 2.3 SDI-12 Related Commands

User need to configure SDI-12-LB to communicate with SDI-12 sensors otherwise the uplink payload will only include a few bytes.

## 2.3.1 Basic SDI-12 debug command

User can run some basic SDI-12 command to debug the connection to the SDI-12 sensor. These commands can be sent via AT Command or LoRaWAN downlink command.

If SDI-12 sensor return value after get these commands, *SDI-12-LB* will uplink the return on FPORT=100, otherwise, if there is no response from SDI-12 sensor. *SDI-12-LB* will uplink NULL (0x 4E 55 4C 4C) to server.

The following is the display information on the serial port and the server.

```
AT+ADDRI=0
AT+ADDRI=0I!
RETURN DATA:
```

OK

Payload = 4E 55 4C 4C

```
***** UpLinkCounter= 9 *****
TX on freq 867.500 MHz at DR 5
txDone
RX on freq 867.500 MHz at DR 5
rxTimeout
RX on freq 869.525 MHz at DR 0
rxTimeout
```

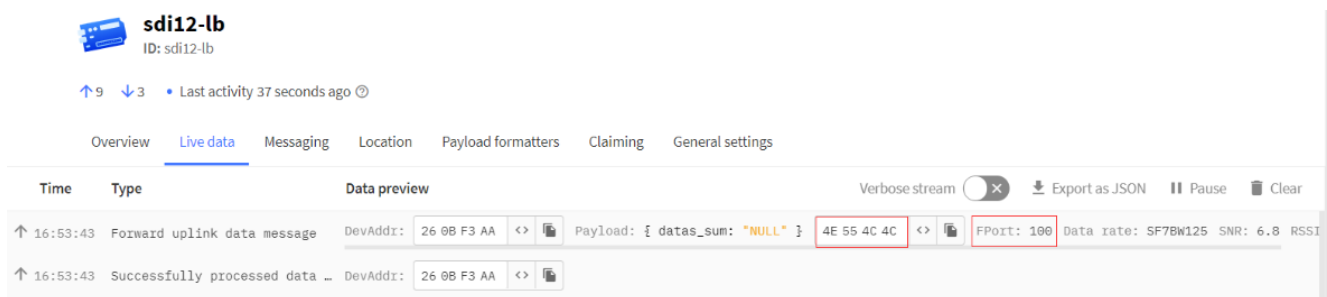

The screenshot shows the web interface for 'sdi12-lb' (ID: sdi12-lb). It features a navigation menu with 'Overview', 'Live data', 'Messaging', 'Location', 'Payload formatters', 'Claiming', and 'General settings'. The 'Live data' section is active, displaying a table of messages. The first message is a 'Forward uplink data message' at 16:53:43, with a DevAddr of 26 0B F3 AA and a Payload of { datas\_sum: "NULL" }. The payload is shown as a hex string '4E 55 4C 4C' and a decimal value 'FPort: 100'. The message also includes 'Data rate: SF7BW125' and 'SNR: 6.8 RSSI'. A second message, 'Successfully processed data ...', is partially visible below.

### al! -- Get SDI-12 sensor Identification

- AT Command: AT+ADDRI=aa
- LoRaWAN Downlink(prefix 0xAA00): AA 00 aa

**Parameter:** aa: ASCII value of SDI-12 sensor address in downlink or HEX value in AT Command)

**Example :** AT+ADDRI=0 ( Equal to downlink: 0x AA 00 30)

The following is the display information on the serial port and the server.



AT+ADDRI=0  
AT+ADDRI=0I!  
RETURN DATA:  
013METER TER12 112T12-00024895

OK

Payload = 30 31 33 4D 45 54 45 52 20 20 20 54 45 52 31 32 20 31 31 32 54 31 32 2D 30 30 30  
32 34 38 39 35 0D 0A

\*\*\*\*\* UpLinkCounter= 1 \*\*\*\*\*  
TX on freq 867.300 MHz at DR 4  
txDone  
RX on freq 867.300 MHz at DR 4  
rxTimeout  
RX on freq 869.525 MHz at DR 0  
rxTimeout

sdi12-lb  
ID: sdi12-lb  
↑1 ↓n/a • Last activity 49 seconds ago

Overview **Live data** Messaging Location Payload formatters Claiming General settings

Time	Type	DevAddr	Payload	FPort	Data rate
↑ 16:43:33	Forward uplink data message	26 0B F3 AA	{ datas_sum: "013METER TER12 112T12-00024895\r\n" }	100	SF8BW125
↑ 16:43:33	Successfully processed data messa...	26 0B F3 AA			

## aM!,aMC!, aM1!- aM9!, aMC1!- aMC9!

**aM!** : Start Non-Concurrent Measurement

**aMC!** : Start Non-Concurrent Measurement – Request CRC

**aM1!- aM9!** : Additional Measurements

**aMC1!- aMC9!** : Additional Measurements – Request CRC

- AT Command : AT+ADDRM=0,1,0,1
- LoRaWAN Downlink(prefix 0xAA01): 0xAA 01 30 01 00 01

Downlink: AA 01 aa bb cc dd

**aa**: SDI-12 sensor address.

**bb**: 0: no CRC, 1: request CRC

**cc**: 1-9: Additional Measurement, 0: no additional measurement

**dd**: delay (in second) to send **aD0!** to get return.

The following is the display information on the serial port and the server.

AT+ADDRM=0,1,0,1  
AT+ADDRM=0MC!  
RETURN DATA:  
0+1825.16+25.0+1Bxy

OK

Payload = 30 2B 31 38 32 35 2E 31 36 2B 32 35 2E 30 2B 31 42 78 79 0D 0A

\*\*\*\*\* UpLinkCounter= 2 \*\*\*\*\*  
TX on freq 867.700 MHz at DR 4  
txDone  
RX on freq 867.700 MHz at DR 4

Received: ADR Message

rxDone  
Rssi= -63

The screenshot shows a network manager interface for a device named 'sdi12-lb'. It displays a list of messages with columns for Time, Type, and Data preview. The selected message is a 'Forward uplink data message' at 16:44:58. The data preview shows the payload: [ datas\_sum: "0+1825.16+25.0+1Bxy\r\n" ] and the hex representation: 30 2B 31 38 32 35 2E 31 36 2B 32 35 2E 30 2B 31 42 78 79 0D 0A. The interface also shows the device address (26 9B F3 AA) and various settings like 'FPort: 100', 'Data rate: SF8Bw125', and 'SNR: 10.2'.

## aC!, aCC!, aC1!- aC9!, aCC1!- aCC9!

**aC!** : Start Concurrent Measurement

**aCC!** : Start Concurrent Measurement – Request CRC

**aC1!- aC9!** : Start Additional Concurrent Measurements

**aCC1!- aCC9!** : Start Additional Concurrent Measurements – Request CRC

- AT Command : AT+ADDRM=0,1,0,1
- LoRaWAN Downlink(0xAA02): 0xAA 02 30 01 00 01

Downlink: AA 02 aa bb cc dd

**aa**: SDI-12 sensor address.

**bb**: 0: no CRC, 1: request CRC

**cc**: 1-9: Additional Measurement, 0: no additional measurement

**dd**: delay (in second) to send **aD0!** to get return.

The following is the display information on the serial port and the server.

```
AT+ADDRC=0,1,0,1
AT+ADDRC=0CC!
RETURN DATA:
0+1825.58+25.3+0JJ{
```

OK

Payload = 30 2B 31 38 32 35 2E 35 38 2B 32 35 2E 33 2B 30 4A 4A 7B 0D 0A

```
***** UpLinkCounter= 3 *****
TX on freq 868.500 MHz at DR 5
txDone
RX on freq 868.500 MHz at DR 5
rxTimeout
RX on freq 869.525 MHz at DR 0
rxTimeout
```

The screenshot shows a web interface for a LoRaWAN network server. At the top, there is a device icon and name 'sdi12-lb' with ID 'sdi12-lb'. Below it, there are navigation tabs: Overview, Live data (selected), Messaging, Location, Payload formatters, Claiming, and General settings. A message log is visible with two entries. The first entry is a 'Forward upLink data message' at 16:47:32 from device address '26 0B F3 AA'. The payload is shown as a JSON object: { datas\_sum: "0+1825.58+25.3+0JJ{\r\n" }. The second entry is a 'Successfully processed data messa...' at the same time from the same device address. The interface also shows a 'Verbose stream' toggle, 'Export as JSON', 'Pause', and 'Clear' buttons.

## aR0!- aR9!, aRC0!- aRC9!

Start Continuous Measurement

Start Continuous Measurement – Request CRC

- AT Command : AT+ADDRR=0,1,0,1
- LoRaWAN Downlink (0xAA 03): 0xAA 03 30 01 00 01

Downlink: AA 03 aa bb cc dd

**aa**: SDI-12 sensor address.

**bb**: 0: no CRC, 1: request CRC

**cc**: 1-9: Additional Measurement, 0: no additional measurement

**dd**: delay (in second) to send **aD0!** to get return.

The following is the display information on the serial port and the server.

```
AT+ADDRR=0,1,0,1
AT+ADDRR=0RC0!
RETURN DATA:
0+1819.51+25.4+1Itp
```

OK

Payload = 30 2B 31 38 31 39 2E 35 31 2B 32 35 2E 34 2B 31 49 74 70 0D 0A

```
***** UpLinkCounter= 4 *****
TX on freq 867.300 MHz at DR 5
txDone
RX on freq 867.300 MHz at DR 5
rxTimeout
RX on freq 869.525 MHz at DR 0
rxTimeout
```

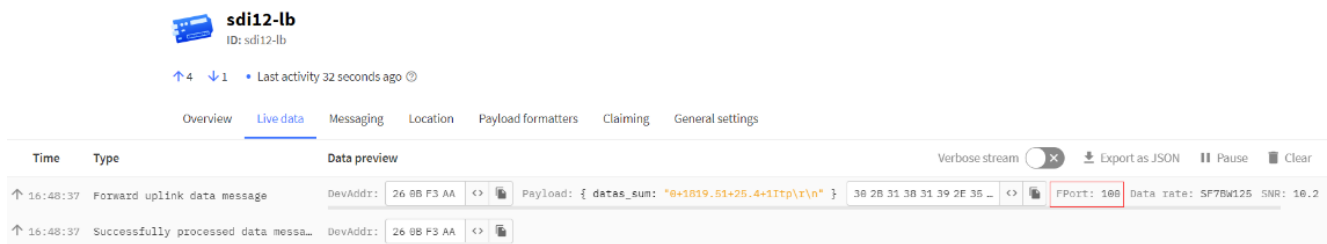

## 2.3.2 Advance SDI-12 Debug command

This command can be used to debug all SDI-12 command.

LoRaWAN Downlink: A8 aa xx xx xx xx bb cc

**aa** : total SDI-12 command length

**xx** : SDI-12 command

**bb** : Delay to wait for return

**cc** : 0: don't uplink return to LoRaWAN, 1: Uplink return to LoRaWAN on FPORT=100

**Example:** AT+CFGDEV =0RC0!,1

**0RC0!** : SDI-12 Command,

**1** : Delay 1 second. ( 0: 810 mini-second)

Equal Downlink: 0xA8 05 30 52 43 30 21 01 01

The following is the display information on the serial port and the server.

```
***** UpLinkCounter= 6 *****
TX on freq 868.500 MHz at DR 5
txDone
RX on freq 868.500 MHz at DR 5
```

```
rxDone
Rssi= -63
AT+CFGDEV=0RC0!,1
RETURN DATA:
0+1818.57+25.5+1Hoe
```

Receive data  
BuffSize:9,Run AT+RECVB=? to see detail

Payload = 30 2B 31 38 31 38 2E 35 37 2B 32 35 2E 35 2B 31 48 6F 65 0D 0A

```
***** UpLinkCounter= 7 *****
TX on freq 867.700 MHz at DR 5
txDone
RX on freq 867.700 MHz at DR 5
rxTimeout
RX on freq 869.525 MHz at DR 0
rxTimeout
```

**sdi12-lb**  
ID: sdi12-lb

↑ 8 ↓ 3 • Last activity 26 seconds ago

Overview Live data Messaging Location Payload formatters Claiming General settings

Time	Type	Data preview
↑ 16:52:12	Successfully processed data ...	DevAddr: 26 0B F3 AA
↑ 16:51:33	Forward uplink data message	DevAddr: 26 0B F3 AA Payload: { datas_sum: "0+1818.57+25.5+1Hoe\r\n" } 30 2B 31 38 31 38 2E 35 ... FPort: 100
↑ 16:51:33	Successfully processed data ...	DevAddr: 26 0B F3 AA
↓ 16:51:27	Schedule data downlink for t...	DevAddr: 26 0B F3 AA FPort: 1 MAC payload: 03 03 94 09 EA 04 F4 DF ... Rx1 Delay: 5
↑ 16:51:27	Forward uplink data message	DevAddr: 26 0B F3 AA Payload: { BatV: 3.328, EXTI_Trigger: "FALSE", Payver: 1 } 00 00 01 FPort: 2 Data rate:
↑ 16:51:27	Successfully processed data ...	DevAddr: 26 0B F3 AA
↓ 16:51:22	Receive downlink data message	Payload: AB 05 30 52 43 30 21 01 FPort: 1

## 2.3.3 Convert ASCII to String

This command is used to convert between ASCII and String format.

AT+CONVFORM ( Max length: 80 bytes)

### Example:

1) AT+CONVFORM=0, string Convert String from String to ASCII

```
AT+CONVFORM=0,0+1823.43+22.6+0LaL
ASCII is:
30 2B 31 38 32 33 34 33 2B 32 32 36 2B 30 4C 61 4C
```

OK

2) AT+CONVFORM=1, ASCII Convert ASCII to String.

```
AT+CONVFORM=1,30 2B 31 38 32 33 34 33 2B 32 32 36 2B 30 4C 61 4C
String is:
0+182343+226+0LaL
```

OK

## 2.3.4 Define periodically SDI-12 commands and uplink.

AT+COMMANDx & AT+DATACUTx

User can define max 15 SDI-12 Commands (AT+COMMAND1 ~ AT+COMMANDF). On each uplink period (TDC time, default 20 minutes), SDI-12-LB will send these SDI-12 commands and wait for return from SDI-12 sensors. SDI-12-LB will then combine these returns and uplink via LoRaWAN.

- **AT Command:**

**AT+COMMANDx=var1,var2,var3,var4.**

**var1:** SDI-12 command , for example: 0RC0!

**var2:** Wait timeout for return. (unit: second)

**var3:** Whether to send *addrD0!* to get return after var2 timeout. 0: Don't Send *addrD0!*; 1: Send *addrD0!*.

**var4:** validation check for return. If return invalid, SDI-12-LB will resend this command. Max 3 retries.

**0** No validation check;

**1** Check if return chars are printable char(0x20 ~ 0x7E);

**2** Check if there is return from SDI-12 sensor

**3** Check if return pass CRC check ( SDI-12 command var1 must include CRC request);

Each AT+COMMANDx is followed by a **AT+DATACUT** command. AT+DATACUT command is used to take the useful string from the SDI-12 sensor so the final payload will have the minimum length to uplink.

**AT+DATACUTx** : This command defines how to handle the return from AT+COMMANDx, max return length is 100 bytes.

**AT+DATA CUTx=a,b,c****a:** length for the return of AT+COMMAND**b:** 1: grab valid value by byte, max 6 bytes. 2: grab valid value by bytes section, max 3 sections.**c:** define the position for valid value.

For example, if return from AT+COMMAND1 is "013METER TER12 112T12-00024895<CR><LF>",  
 Below AT+DATA CUT1 will get different result to combine payload:

AT+DATA CUT1 value	Final Result to combine Payload
34,1,1+2+3	0D 00 01 30 31 33
34,2,1~8+12~16	0D 00 01 30 31 33 4D 45 54 45 52 54 45 52 31 32
34,2,1~34	0D 00 01 30 31 33 4D 45 54 45 52 20 20 20 54 45 52 31 32 20 31 31 32 54 31 32 2D 30 30 30 32 34 38 39 35 0D 0A

- **Downlink Payload:**

**0xAF** downlink command can be used to set AT+COMMANDx or AT+DATA CUTx.

**Note :** if user use AT+COMMANDx to add a new command, he also need to send AT+DATA CUTx downlink.

Format: **AF MM NN LL XX XX XX XX YY**

Where:

- **MM** : the AT+COMMAND or AT+DATA CUT to be set. Value from 01 ~ 0F,
- **NN** : 1: set the AT+COMMAND value ; 2: set the AT+DATA CUT value.
- **LL** : The length of AT+COMMAND or AT+DATA CUT command
- **XX XX XX XX** : AT+COMMAND or AT+DATA CUT command
- **YY** : If YY=0, SDI-12-LB will execute the downlink command without uplink; if YY=1, SDI-12-LB will execute an uplink after got this command.

**Example:**

**AF 03 01 07 30 4D 43 21 01 01 01 00:** Same as AT+COMMAND3= **OMC!**, **1**, **1**, **1**

**AF 03 02 06 10 01 05 06 09 0A 00:** Same as AT+DATA CUT3= **16,1,5+6+9+10**

**AF 03 02 06 0B 02 05 07 08 0A 00:** Same as AT+DATA CUT3= **11,2,5~7+8~10**

**Clear SDI12 Command**

The AT+COMMANDx and AT+DATA CUTx settings are stored in special location, user can use below command to clear them.

- **AT Command:**

**AT+CMDEAR=mm,nn** mm: start position of erase ,nn: stop position of erase

Etc. AT+CMDEAR=1,10 means erase AT+COMMAND1/AT+DATA CUT1 to AT+COMMAND10/AT+DATA CUT10

- **Downlink Payload:**

**0x09 aa bb** same as AT+CMDEAR=aa,bb

**command combination**

Below shows a screen shot how the results combines together to a uplink payload.

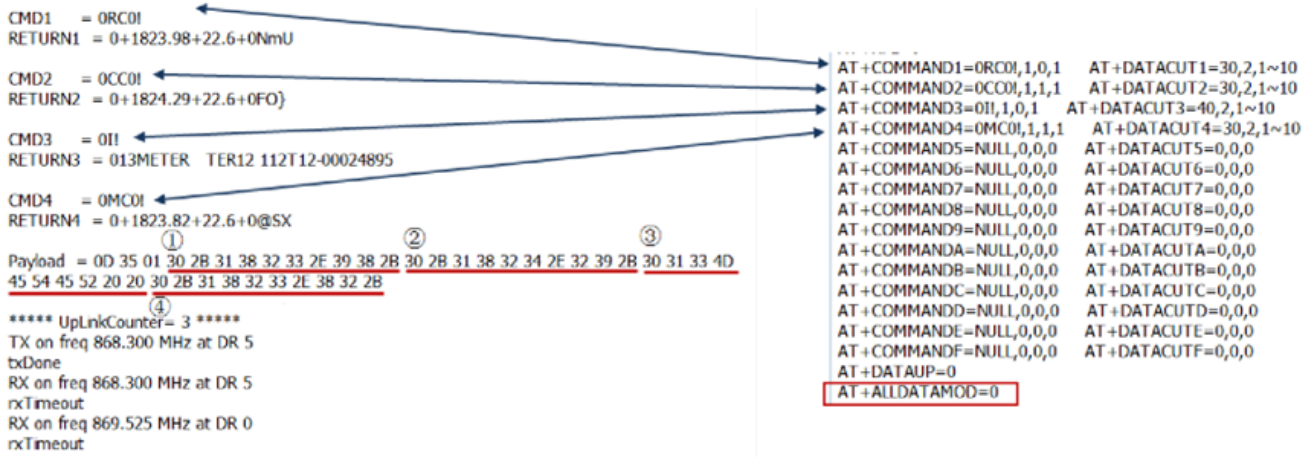

If user don't want to use DATA CUT for some command, he simply want to uplink all returns.

AT+ALLDATAMOD can be set to 1.

**AT+ALLDATAMOD** will simply get all return and don't do CRC check as result for SDI-12 command.

AT+DATA CUTx command has higher priority, if AT+DATA CUTx has been set, AT+ALLDATAMOD will be ignore for this SDI-12 command.

**For example:** as below photo, AT+ALLDATAMOD=1, but AT+DATA CUT1 has been set, AT+DATA CUT1 will be still effect the result.



```

CMD1 = 0RC0!
RETURN1 = 0+1827.09+22.5+1H_Z

CMD2 = 0RC0!
RETURN2 = 0+1823.38+22.5+0Do[

CMD3 = 0II
RETURN3 = 013METER TER12 112T12-00024895

Payload = 0D 35 01 F1 05 30 2B 31 38 32 F2 15 30 2B 31 38 32 33 2E 33 38 2B 32 32 2E 35 2B
30 44 6F 5B 0D 0A F3 22 30 31 33 4D 45 54 45 52 20 20 54 45 52 31 32 20 31 31 32 54 31 32
2D 30 30 30 32 34 38 39 35 0D 0A

***** UpLinkCounter= 1 *****
TX on freq 868.500 MHz at DR 5
txDone
RX on freq 868.500 MHz at DR 5
rxTimeout
RX on freq 869.525 MHz at DR 0
rxTimeout

AT+COMMAND1=0RC0!,1,0,1 AT+DATAACUT1=22,2,1~5
AT+COMMAND2=0RC0!,1,0,1 AT+DATAACUT2=0,0,0
AT+COMMAND3=0II,1,0,1 AT+DATAACUT3=0,0,0
AT+COMMAND4=NULL,0,0,0 AT+DATAACUT4=0,0,0
AT+COMMAND5=NULL,0,0,0 AT+DATAACUT5=0,0,0
AT+COMMAND6=NULL,0,0,0 AT+DATAACUT6=0,0,0
AT+COMMAND7=NULL,0,0,0 AT+DATAACUT7=0,0,0
AT+COMMAND8=NULL,0,0,0 AT+DATAACUT8=0,0,0
AT+COMMAND9=NULL,0,0,0 AT+DATAACUT9=0,0,0
AT+COMMANDA=NULL,0,0,0 AT+DATAACUTA=0,0,0
AT+COMMANDB=NULL,0,0,0 AT+DATAACUTB=0,0,0
AT+COMMANDC=NULL,0,0,0 AT+DATAACUTC=0,0,0
AT+COMMANDD=NULL,0,0,0 AT+DATAACUTD=0,0,0
AT+COMMANDE=NULL,0,0,0 AT+DATAACUTE=0,0,0
AT+COMMANDF=NULL,0,0,0 AT+DATAACUTF=0,0,0
AT+DATAUP=0
AT+ALLDATAMOD=1

```

If AT+ALLDATAMOD=1, **FX,X** will be added in the payload, FX specify which command is used and X specify the length of return. for example in above screen, F1 05 means the return is from AT+COMMAND1 and the return is 5 bytes.

### Compose Uplink

#### AT+DATAUP=0

Compose the uplink payload with value returns in sequence and send with **A SINGLE UPLINK**.

Final Payload is **Battery Info+PAYVER + VALID Value from RETURN1 + Valid Value from RETURN2 + ... + RETURNx**

Where PAYVER is defined by AT+PAYVER, below is an example screen shot.

```

CMD1 = 0RC0!
RETURN1 = 0+1823.98+22.6+0NmU

CMD2 = 0CC0!
RETURN2 = 0+1824.29+22.6+0FO}

CMD3 = 0II
RETURN3 = 013METER TER12 112T12-00024895

CMD4 = 0MC0!
RETURN4 = 0+1823.82+22.6+0@SX
Battery Info
PAYVER

Payload = 0D 35 01 30 2B 31 38 32 33 2E 39 38 2B 30 2B 31 38 32 34 2E 32 39 2B 30 31 33 4D
45 54 45 52 20 20 30 2B 31 38 32 33 2E 38 32 2B

***** UpLinkCounter= 3 *****
TX on freq 868.300 MHz at DR 5
txDone
RX on freq 868.300 MHz at DR 5
rxTimeout
RX on freq 869.525 MHz at DR 0
rxTimeout

AT+COMMAND1=0RC0!,1,0,1 AT+DATAACUT1=30,2,1~10
AT+COMMAND2=0CC0!,1,1,1 AT+DATAACUT2=30,2,1~10
AT+COMMAND3=0II,1,0,1 AT+DATAACUT3=40,2,1~10
AT+COMMAND4=0MC0!,1,1,1 AT+DATAACUT4=30,2,1~10
AT+COMMAND5=NULL,0,0,0 AT+DATAACUT5=0,0,0
AT+COMMAND6=NULL,0,0,0 AT+DATAACUT6=0,0,0
AT+COMMAND7=NULL,0,0,0 AT+DATAACUT7=0,0,0
AT+COMMAND8=NULL,0,0,0 AT+DATAACUT8=0,0,0
AT+COMMAND9=NULL,0,0,0 AT+DATAACUT9=0,0,0
AT+COMMANDA=NULL,0,0,0 AT+DATAACUTA=0,0,0
AT+COMMANDB=NULL,0,0,0 AT+DATAACUTB=0,0,0
AT+COMMANDC=NULL,0,0,0 AT+DATAACUTC=0,0,0
AT+COMMANDD=NULL,0,0,0 AT+DATAACUTD=0,0,0
AT+COMMANDE=NULL,0,0,0 AT+DATAACUTE=0,0,0
AT+COMMANDF=NULL,0,0,0 AT+DATAACUTF=0,0,0
AT+DATAUP=0
AT+ALLDATAMOD=0

```

#### AT+DATAUP=1

Compose the uplink payload with value returns in sequence and send with **Multiply UPLINKS**.

Final Payload is **Battery Info+PAYVER + PAYLOAD COUNT + PAYLOAD# + DATA**

1. Battery Info (2 bytes): Battery voltage
2. PAYVER (1 byte): Defined by AT+PAYVER
3. PAYLOAD COUNT (1 byte): Total how many uplinks of this sampling.
4. PAYLOAD# (1 byte): Number of this uplink. (from 0,1,2,3...,to PAYLOAD COUNT)
5. DATA: Valid value: max 6 bytes(US915 version here, Notice\*) for each uplink so each uplink <= 11

bytes. For the last uplink, DATA will might less than 6 bytes

```

CMD1 = ORC01
RETURN1 = 0+1814.61+22.5+000z

CMD2 = ORC01
RETURN2 = 0+1814.78+22.5+000w

CMD3 = 011
RETURN3 = 013METER TER12_112T12-00024895

Payload = 00 00 01 02 00 00 20 31 38 31 34 2E 36 31 28 32 2E 35 28 30 40 44 7A 00 00 00 20 31 38 31 34 2E 37 38 28 32 2E 35 28 30 4F 6F 77 00 00 00 30 31 33 4D
          ① ② ③
***** UplinkCounter= 6 *****

TX on Freq 868.300 MHz at DR 0
TxDone
RX on Freq 868.300 MHz at DR 0
rxTimeout
RX on Freq 869.525 MHz at DR 0
rxTimeout

CMD1 = ORC01
RETURN1 = 0+1814.61+22.5+000z

CMD2 = ORC01
RETURN2 = 0+1814.78+22.5+000w

CMD3 = 011
RETURN3 = 013METER TER12_112T12-00024895

Payload = 00 00 01 02 01 45 54 45 52 20 20 20 54 45 52 31 32 20 31 31 32 54 31 32 20 30 30 30 32 34 38 39 35 00 00
          ① ② ③
***** UplinkCounter= 7 *****

TX on Freq 868.300 MHz at DR 0
TxDone
RX on Freq 868.300 MHz at DR 0
rxTimeout
RX on Freq 869.525 MHz at DR 0
rxTimeout

```

First Uplink

Second Uplink

**Notice: the Max bytes is according to the max support bytes in different Frequency Bands for lowest SF. As below:**

- For AU915/AS923 bands, if UplinkDwell time=0, max 51 bytes for each uplink ( so 51 -5 = 46 max valid date)
- For AU915/AS923 bands, if UplinkDwell time=1, max 11 bytes for each uplink ( so 11 -5 = 6 max valid date).
- For US915 band, max 11 bytes for each uplink ( so 11 -5 = 6 max valid date).
- For all other bands: max 51 bytes for each uplink ( so 51 -5 = 46 max valid date).

**When AT+DATAUP=1, the maximum number of segments is 15, and the maximum total number of bytes is 1500;**

**When AT+DATAUP=1 and AT+ADR=0, the maximum number of bytes of each payload is determined by the DR value.**

## 2.4 Uplink Payload

### 2.4.1 Device Payload, FPORT=5

Include device configure status. Once SDI-12-LB Joined the network, it will uplink this message to the server.

Users can also use the downlink command(0x26 01) to ask SDI-12-LB to resend this uplink.

Device Status (FPORT=5)					
Size(bytes)	1	2	1	1	2
Value	Sensor Model	Firmware Version	Frequency Band	Sub-band	BAT

## Example parse in TTNv3

The screenshot shows the TTNv3 interface for device 'sdi12-lb'. The 'Live data' tab is active, displaying a table of messages. The first message is a 'Forward uplink data message' at 16:58:55. The payload is: { BAT: 3.328, FIRMWARE\_VERSION: "1.0.0", FREQUENCY\_BAND: "EU868", SENSOR\_MODEL: "SDI12-LB", SUB\_BAND: "NULL" }. The second message is 'Successfully processed data' at 16:58:55, with DevAddr: 26 08 F3 AA.

**Sensor Model:** For SDI-12-LB, this value is 0x17

**Firmware Version:** 0x0100, Means: v1.0.0 version

### Frequency Band:

\*0x01: EU868

\*0x02: US915

\*0x03: IN865

\*0x04: AU915

\*0x05: KZ865

\*0x06: RU864

\*0x07: AS923

\*0x08: AS923-1

\*0x09: AS923-2

\*0x0a: AS923-3

\*0x0b: CN470

\*0x0c: EU433

\*0x0d: KR920

\*0x0e: MA869

### Sub-Band:

AU915 and US915: value 0x00 ~ 0x08

CN470: value 0x0B ~ 0x0C

Other Bands: Always 0x00

### Battery Info:

Check the battery voltage.

Ex1: 0x0B45 = 2885mV

Ex2: 0x0B49 = 2889mV

## 2.4.2 Uplink Payload, FPORT=2

There are different cases for uplink. See below

- SDI-12 Debug Command return: FPORT=100
- Periodically Uplink: FPORT=2

Size(bytes)	2	1	Length depends on the return from the commands
Value	Battery(mV) & Interrupt_Flag	PAYLOAD_VER	If the valid payload is too long and exceed the maximum support. Payload length in server,server will show payload not provided in the LoRaWAN server.

The screenshot shows the LoRaWAN console for device 'sdi12-lb'. The 'Live data' tab is selected, displaying a list of uplink messages. The most recent message at 17:02:25 is a 'Forward uplink data message' with a payload: { BatV: 3.328, EXTI\_Trigger: 'FALSE', Payver: 1, data\_sum: '013METER TER12 112712-000248' }. The interface includes navigation tabs like Overview, Messaging, Location, and settings for the device.

## 2.4.3 Battery Info

Check the battery voltage for SDI-12-LB.

Ex1: 0x0B45 = 2885mV

Ex2: 0x0B49 = 2889mV

## 2.4.4 Interrupt Pin

This data field shows if this packet is generated by **Interrupt Pin** or not. Click here for the hardware and software set up. Note: The Internet Pin is a separate pin in the screw terminal. See pin mapping.

## Example:

Ex1: 0x0B45:0x0B&0x80= 0x00 Normal uplink packet.

Ex2: 0x8B49:0x8B&0x80= 0x80 Interrupt Uplink Packet.

## 2.4.5 Payload version

The version number of the payload, mainly used for decoding. The default is 01.

## 2.4.6 Decode payload in The Things Network

While using TTN network, you can add the payload format to decode the payload.

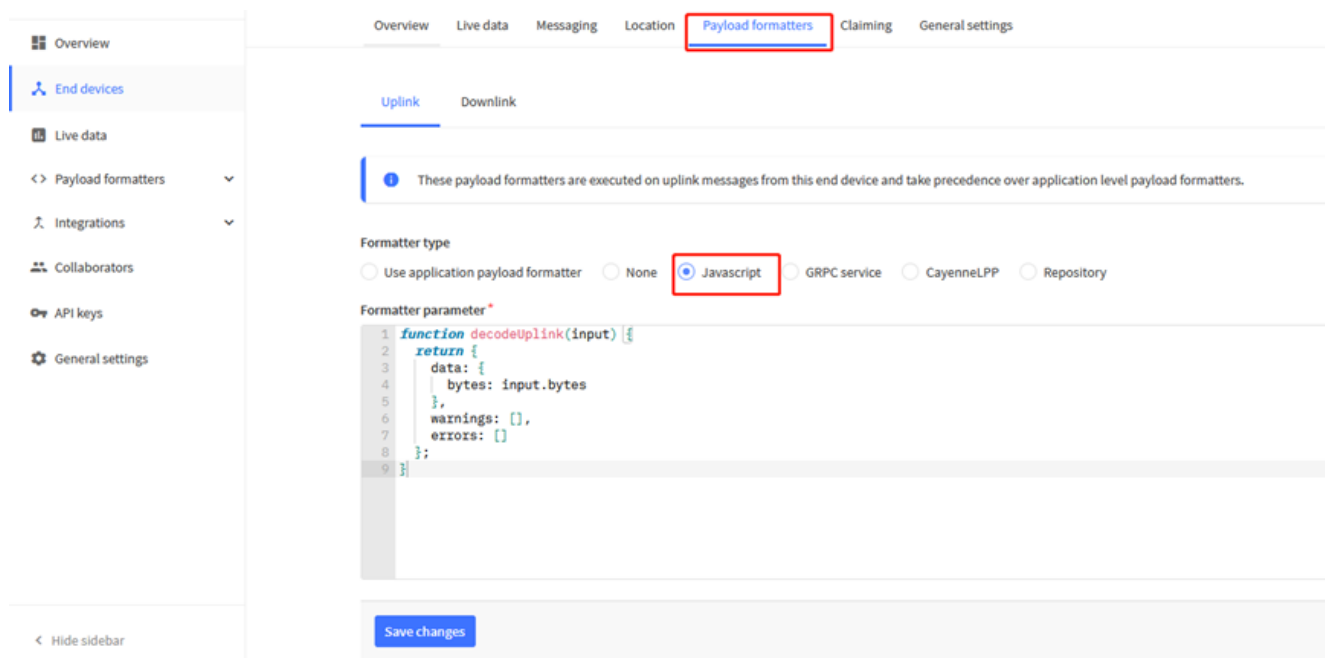

The screenshot shows the TTN Payload Formatters configuration page. The left sidebar contains navigation options: Overview, End devices, Live data, Payload formatters (selected), Integrations, Collaborators, API keys, and General settings. The main content area has tabs for Overview, Live data, Messaging, Location, Payload formatters (selected), Claiming, and General settings. Below the tabs, there are sub-tabs for Uplink and Downlink. A blue information box states: "These payload formatters are executed on uplink messages from this end device and take precedence over application level payload formatters." Under "Formatter type", the "Javascript" radio button is selected and highlighted with a red box. Below this, the "Formatter parameter" field contains a JavaScript function: 

```
1 function decodeUplink(input) {  
2   return {  
3     data: {  
4       bytes: input.bytes  
5     },  
6     warnings: [],  
7     errors: []  
8   };  
9 }
```

 A "Save changes" button is located at the bottom of the configuration area.

There is no fix payload decoder in LoRaWAN server because the SDI-12 sensors returns are different. User need to write the decoder themselves for their case.

SDI-12-LB TTN Payload Decoder: <https://github.com/dragino/dragino-end-node-decoder>  
(<https://github.com/dragino/dragino-end-node-decoder>)

## 2.5 Uplink Interval

The SDI-12-LB by default uplink the sensor data every 20 minutes. User can change this interval by AT Command or LoRaWAN Downlink Command. See this link:

<http://wiki.dragino.com/xwiki/bin/view/Main/End%20Device%20AT%20Commands%20and%20Downlink%20Command/#H4.1ChangeUplinkInterval> ([http://wiki.dragino.com/xwiki/bin/view](http://wiki.dragino.com/xwiki/bin/view/Main/End%20Device%20AT%20Commands%20and%20Downlink%20Command/#H4.1ChangeUplinkInterval)

/Main/End%20Device%20AT%20Commands%20and%20Downlink%20Command  
/#H4.1ChangeUplinkInterval)

## 2.6 Examples To Set SDI commands.

### 2.6.1 Examples 1

COM port and SDI-12 sensor communication converted to SDI-12-LB and SDI-12 sensor communication.

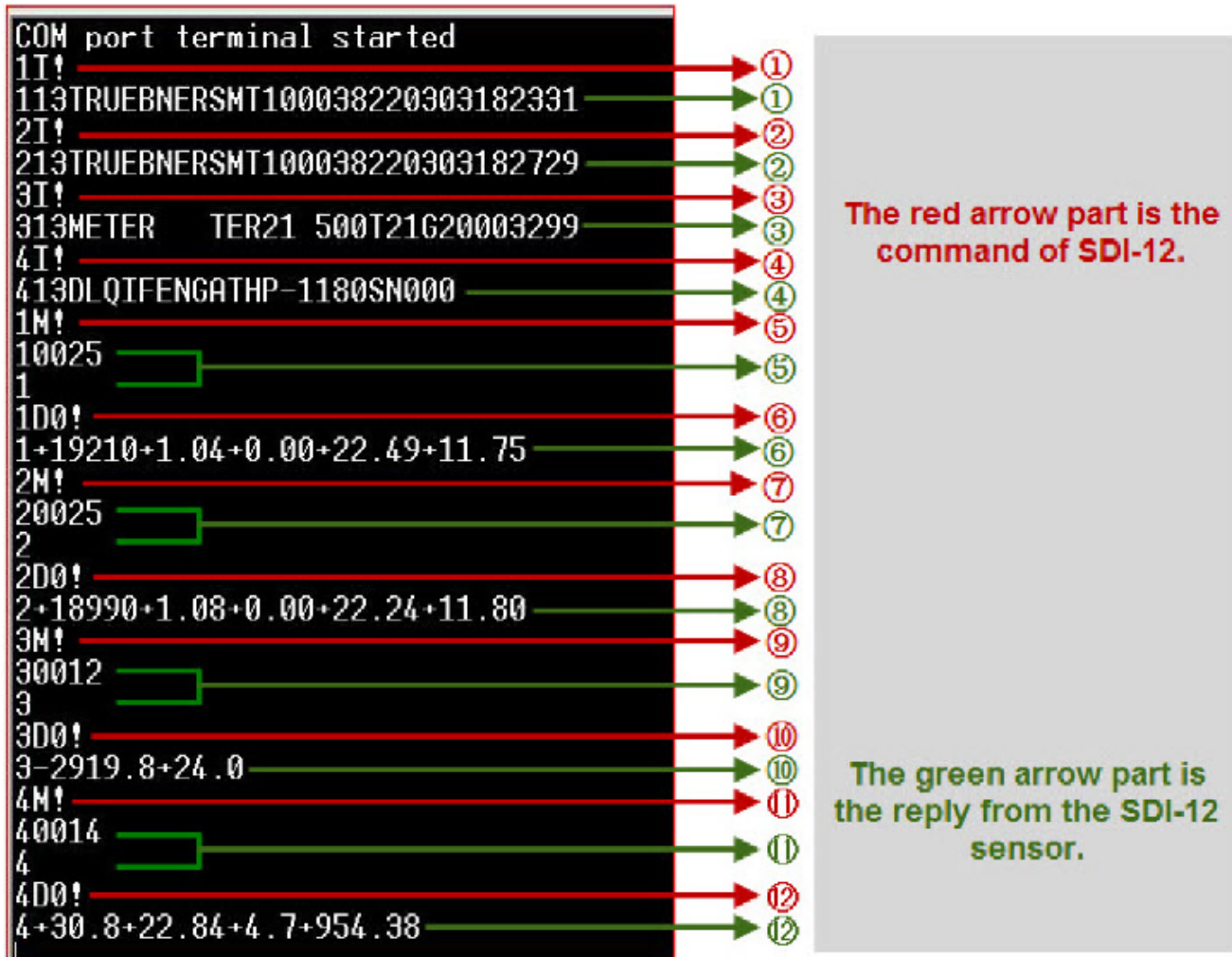

1) The AT+COMMANDx command is applied to the red arrow part, and sends the SDI12 command to the SDI12 sensor:

a. Send the first command and get the first reply:

**AT+COMMANDx=1I!,0,0,1**

b. Send the second command and get the second reply:

**AT+COMMANDx=2I!,0,0,1**

c. Send the third command and get the third reply:

**AT+COMMANDx=3I!,0,0,1**

d. Send the fourth command and get the fourth reply:

**AT+COMMANDx=4I!,0,0,1**

e. Send the fifth command plus the sixth command, get the sixth reply:

**AT+COMMANDx=1M!,2,1,1**

f. Send the seventh command plus the eighth command, get the eighth reply:

**AT+COMMANDx=2M!,2,1,1**

g. Send the ninth command plus the tenth command, get the tenth reply:

**AT+COMMANDx=3M!,1,1,1**

h. Send the eleventh command plus the twelfth command, get the twelfth reply:

**AT+COMMANDx=4M!,1,1,1**

**2) The AT+DATA CUTx command is applied to the green arrow part, receiving and cut out data from the SDI12 sensor:**

a. The first reply, all 34 characters: "113TRUEBNERSMT100038220303182331<CR><LF>"

Cut out all characters: **AT+ALLDATAMOD=1** or **AT+DATA CUTx=34,2,1~34;**

b. The sixth reply, all 31 characters: "1+19210+1.04+0.00+22.49+11.75<CR><LF>"

Cut out all characters: **AT+ALLDATAMOD=1** or **AT+DATA CUTx=31,2,1~31;**

c. The eighth reply, all 31 characters: "2+18990+1.08+0.00+22.24+11.80<CR><LF>"

Cut out all characters: **AT+ALLDATAMOD=1** or **AT+DATA CUTx=31,2,1~31;**

d. The tenth reply, all 15 characters: "3-2919.8+24.0<CR><LF>"

Cut out all characters: **AT+ALLDATAMOD=1** or **AT+DATA CUTx=15,2,1~15;**

e. The twelfth reply, all 25 characters: "4+30.8+22.84+4.7+954.38<CR><LF>"

Partial cut, the cut sensor address and the first two parameters: **AT+DATA CUTx=25,2,1~12, cut out the character field " 4+30.8+22.84".**

## 2.7 Frequency Plans

The SDI-12-LB uses OTAA mode and below frequency plans by default. If user want to use it with different frequency plan, please refer the AT command sets.

<http://wiki.dragino.com/xwiki/bin/view/Main/End%20Device%20Frequency%20Band/>  
(<http://wiki.dragino.com/xwiki/bin/view/Main/End%20Device%20Frequency%20Band/>)

## 2.8 Firmware Change Log

### Firmware download link:

[https://www.dropbox.com/sh/qrbgbikb109lkiv/AACBR-v\\_ZhZAMengcY7Nsa1ja?dl=0](https://www.dropbox.com/sh/qrbgbikb109lkiv/AACBR-v_ZhZAMengcY7Nsa1ja?dl=0)  
([https://www.dropbox.com/sh/qrbgbikb109lkiv/AACBR-v\\_ZhZAMengcY7Nsa1ja?dl=0](https://www.dropbox.com/sh/qrbgbikb109lkiv/AACBR-v_ZhZAMengcY7Nsa1ja?dl=0))

## 3. Configure SDI-12-LB via AT Command or LoRaWAN Downlink

Use can configure SDI-12-LB via AT Command or LoRaWAN Downlink.

- AT Command Connection: See FAQ.
- LoRaWAN Downlink instruction for different platforms: See IoT LoRaWAN Server (<http://wiki.dragino.com/xwiki/bin/view/Main/>) section.

There are two kinds of commands to configure SDI-12-LB, they are:

- **General Commands.**

These commands are to configure:

- General system settings like: uplink interval.
- LoRaWAN protocol & radio related command.

They are same for all Dragino Device which support DLWS-005 LoRaWAN Stack. These commands can be found on the wiki:

<http://wiki.dragino.com/xwiki/bin/view/Main/End%20Device%20AT%20Commands%20and%20Downlink%20Command/>  
(<http://wiki.dragino.com/xwiki/bin/view/Main/End%20Device%20AT%20Commands%20and%20Downlink%20Command/>)

- **Commands special design for SDI-12-LB**

These commands only valid for SDI-12-LB, as below:

### 3.1 Set Transmit Interval Time

Feature: Change LoRaWAN End Node Transmit Interval.

#### AT Command: AT+TDC

Command Example	Function	Response
-----------------	----------	----------



AT+TDC=?	Show current transmit Interval	30000 OK the interval is 30000ms = 30s
AT+TDC=60000	Set Transmit Interval	OK Set transmit interval to 60000ms = 60 seconds

### Downlink Command: 0x01

Format: Command Code (0x01) followed by 3 bytes time value.

If the downlink payload=0100003C, it means set the END Node's Transmit Interval to 0x00003C=60(S), while type code is 01.

- Example 1: Downlink Payload: 0100001E // Set Transmit Interval (TDC) = 30 seconds
- Example 2: Downlink Payload: 0100003C // Set Transmit Interval (TDC) = 60 seconds

## 3.2 Set Interrupt Mode

Feature, Set Interrupt mode for GPIO\_EXIT.

### AT Command: AT+INTMOD

Command Example	Function	Response
AT+INTMOD=?	Show current interrupt mode	0 OK the mode is 0 = Disable Interrupt
AT+INTMOD=2	Set Transmit Interval 0. (Disable Interrupt), 1. (Trigger by rising and falling edge) 2. (Trigger by falling edge) 3. (Trigger by rising edge)	OK

### Downlink Command: 0x06

Format: Command Code (0x06) followed by 3 bytes.

This means that the interrupt mode of the end node is set to 0x000003=3 (rising edge trigger), and the type code is 06.

- Example 1: Downlink Payload: 06000000 // Turn off interrupt mode

- Example 2: Downlink Payload: 06000003 // Set the interrupt mode to rising edge trigger

### 3.3 Set the output time

Feature, Control the output 3V3 , 5V or 12V.

#### AT Command: AT+3V3T

Command Example	Function	Response
AT+3V3T=?	Show 3V3 open time.	0 OK
AT+3V3T=0	Normally open 3V3 power supply.	OK default setting
AT+3V3T=1000	Close after a delay of 1000 milliseconds.	OK
AT+3V3T=65535	Normally closed 3V3 power supply.	OK

#### AT Command: AT+5VT

Command Example	Function	Response
AT+5VT=?	Show 5V open time.	0 OK
AT+5VT=0	Normally closed 5V power supply.	OK default setting
AT+5VT=1000	Close after a delay of 1000 milliseconds.	OK
AT+5VT=65535	Normally open 5V power supply.	OK

#### AT Command: AT+12VT

Command Example	Function	Response
AT+12VT=?	Show 12V open time.	0 OK

AT+12VT=0	Normally closed 12V power supply.	OK
AT+12VT=500	Close after a delay of 500 milliseconds.	OK

### Downlink Command: 0x07

Format: Command Code (0x07) followed by 3 bytes.

The first byte is which power, the second and third bytes are the time to turn on.

- Example 1: Downlink Payload: 070101F4 ---> AT+3V3T=500
- Example 2: Downlink Payload: 0701FFFF ---> AT+3V3T=65535
- Example 3: Downlink Payload: 070203E8 ---> AT+5VT=1000
- Example 4: Downlink Payload: 07020000 ---> AT+5VT=0
- Example 5: Downlink Payload: 070301F4 ---> AT+12VT=500
- Example 6: Downlink Payload: 07030000 ---> AT+12VT=0

## 3.4 Set the all data mode

Feature, Set the all data mode.

### AT Command: AT+ALLDATAMOD

Command Example	Function	Response
AT+ALLDATAMOD=?	Show current all data mode	0 OK
AT+ALLDATAMOD=1	Set all data mode is 1.	OK

### Downlink Command: 0xAB

Format: Command Code (0xAB) followed by 1 bytes.

- Example 1: Downlink Payload: AB 00 // AT+ALLDATAMOD=0
- Example 2: Downlink Payload: AB 01 // AT+ALLDATAMOD=1

## 3.5 Set the splicing payload for uplink

Feature, splicing payload for uplink.

### AT Command: AT+DATAUP

Command Example	Function	Response
AT+DATAUP=?	Show current splicing payload for uplink mode	0 OK
AT+DATAUP=0	Set splicing payload for uplink mode is 0.	OK
AT+DATAUP=1	Set splicing payload for uplink mode is 1 , and the each splice uplink is sent sequentially.	OK
AT+DATAUP=1,20000	Set splicing payload for uplink mode is 1, and the uplink interval of each splice to 20000 milliseconds.	OK

#### Downlink Command: 0xAD

Format: Command Code (0xAD) followed by 1 bytes or 5 bytes.

- Example 1: Downlink Payload: AD 00 // AT+DATAUP=0
- Example 2: Downlink Payload: AD 01 // AT+DATAUP=1
- Example 3: Downlink Payload: AD 01 00 00 14 // AT+DATAUP=1,20000

This means that the interval is set to 0x000014=20S

## 3.6 Set the payload version

Feature, Set the payload version.

#### AT Command: AT+PAYVER

Command Example	Function	Response
AT+PAYVER=?	Show current payload version	1 OK
AT+PAYVER=5	Set payload version is 5.	OK

#### Downlink Command: 0xAE

Format: Command Code (0xAE) followed by 1 bytes.

- Example 1: Downlink Payload: AE 01 // AT+PAYVER=1
- Example 2: Downlink Payload: AE 05 // AT+PAYVER=5

## 4. Battery & how to replace

### 4.1 Battery Type

SDI-12-LB is equipped with a 8500mAh ER26500 Li-SOCI<sub>2</sub> battery (<https://www.dropbox.com/sh/w9l2oa3ytpculph/AAAPtt-apH4lYfCj-2Y6lHvQa?dl=0>). The battery is un-rechargeable battery with low discharge rate targeting for 8~10 years use. This type of battery is commonly used in IoT target for long-term running, such as water meter.

The discharge curve is not linear so can't simply use percentage to show the battery level. Below is the battery performance.

#### 1. Typical discharge profile at +20 °C (Typical value)

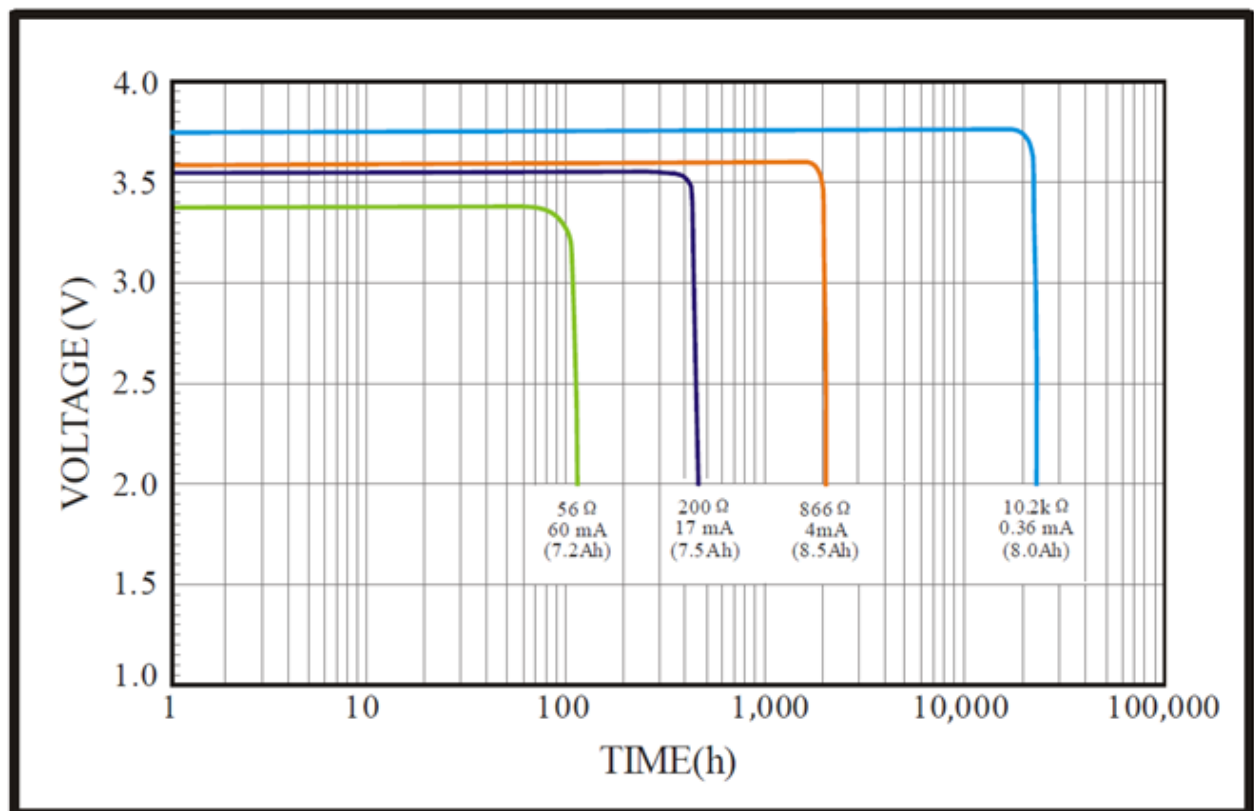

Minimum Working Voltage for the SDI-12-LB:

SDI-12-LB: 2.45v ~ 3.6v

### 4.2 Replace Battery

Any battery with range 2.45 ~ 3.6v can be a replacement. We recommend to use Li-SOCI<sub>2</sub> Battery.

And make sure the positive and negative pins match.

## 4.3 Power Consumption Analyze

Dragino Battery powered product are all runs in Low Power mode. We have an update battery calculator which base on the measurement of the real device. User can use this calculator to check the battery life and calculate the battery life if want to use different transmit interval.

Instruction to use as below:

**Step 1:** Downlink the up-to-date DRAGINO\_Battery\_Life\_Prediction\_Table.xlsx from: [https://www.dropbox.com/sh/zwex6i331j5oeq2/AACIMf9f\\_v2qsJ39CuMQ5Py\\_a?dl=0](https://www.dropbox.com/sh/zwex6i331j5oeq2/AACIMf9f_v2qsJ39CuMQ5Py_a?dl=0) ([https://www.dropbox.com/sh/zwex6i331j5oeq2/AACIMf9f\\_v2qsJ39CuMQ5Py\\_a?dl=0](https://www.dropbox.com/sh/zwex6i331j5oeq2/AACIMf9f_v2qsJ39CuMQ5Py_a?dl=0))

**Step 2:** Open it and choose

- Product Model
- Uplink Interval
- Working Mode

And the Life expectation in difference case will be shown on the right.

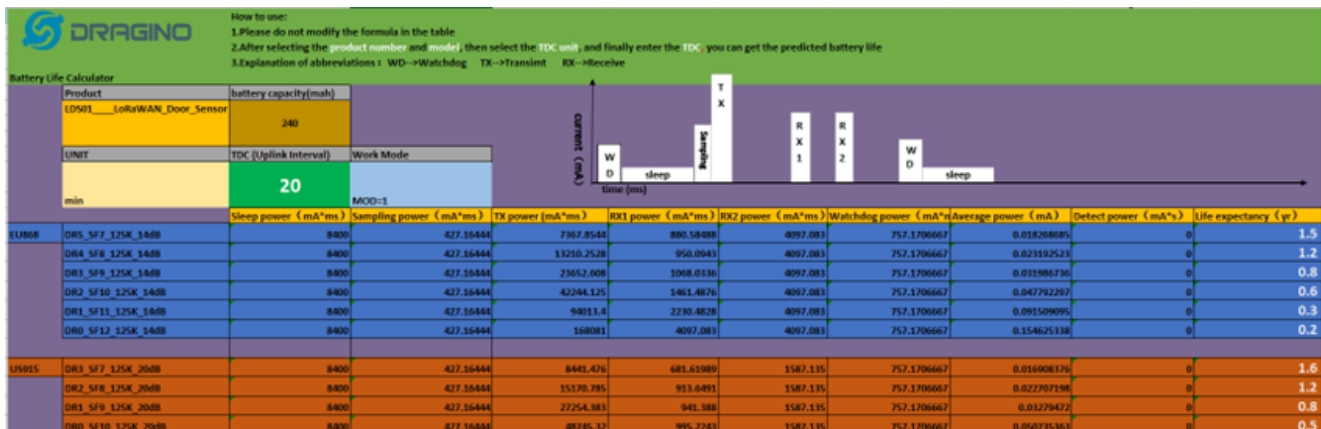

The battery related documents as below:

- Battery Dimension (<https://www.dropbox.com/s/ox5g9njwjl7aw3/LSN50-Battery-Dimension.pdf?dl=0>) ,
- Lithium-Thionyl Chloride Battery datasheet, Tech Spec (<https://www.dropbox.com/sh/d4oyfnp8o94180o/AABQewCNSH5GPeQH86UxRgQQa?dl=0>)
- Lithium-ion Battery-Capacitor datasheet ([https://www.dropbox.com/s/791gjes2lcbfi1p/SPC\\_1520\\_datasheet.jpg?dl=0](https://www.dropbox.com/s/791gjes2lcbfi1p/SPC_1520_datasheet.jpg?dl=0)) , Tech Spec (<https://www.dropbox.com/s/4pkepr9qqqvtzf2/SPC1520%20Technical%20Specification20171123.pdf?dl=0>)



### 4.3.1 Battery Note

The Li-SiCO battery is designed for small current / long period application. It is not good to use a high current, short period transmit method. The recommended minimum period for use of this battery is 5 minutes. If you use a shorter period time to transmit LoRa, then the battery life may be decreased.

### 4.3.2 Replace the battery

You can change the battery in the SDI-12-LB. The type of battery is not limited as long as the output is between 3v to 3.6v. On the main board, there is a diode (D1) between the battery and the main circuit. If you need to use a battery with less than 3.3v, please remove the D1 and shortcut the two pads of it so there won't be voltage drop between battery and main board.

The default battery pack of SDI-12-LB includes a ER26500 plus super capacitor. If user can't find this pack locally, they can find ER26500 or equivalence, which will also work in most case. The SPC can enlarge the battery life for high frequency use (update period below 5 minutes)

## 5. Remote Configure device

### 5.1 Connect via BLE

Please see this instruction for how to configure via BLE: <http://wiki.dragino.com/xwiki/bin/view/Main/BLE%20Bluetooth%20Remote%20Configure/> (<http://wiki.dragino.com/xwiki/bin/view/Main/BLE%20Bluetooth%20Remote%20Configure/>)

### 5.2 AT Command Set

## 6. OTA firmware update

Please see this link for how to do OTA firmware update.

<http://wiki.dragino.com/xwiki/bin/view/Main/Firmware%20OTA%20Update%20for%20Sensors/>  
(<http://wiki.dragino.com/xwiki/bin/view/Main/Firmware%20OTA%20Update%20for%20Sensors/>)

## 7. FAQ

### 7.1 How to use AT Command to access device?

See: <http://wiki.dragino.com/xwiki/bin/view/Main/UART%20Access%20for%20LoRa%20ST%20v4%20base%20model/#H1.LoRaSTv4baseHardware> (<http://wiki.dragino.com/xwiki/bin/view/Main/UART%20Access%20for%20LoRa%20ST%20v4%20base%20model/#H1.LoRaSTv4baseHardware>)

### 7.2 How to update firmware via UART port?

See: <http://wiki.dragino.com/xwiki/bin/view/Main/UART%20Access%20for%20LoRa%20ST%20v4%20base%20model/#H1.LoRaSTv4baseHardware> (<http://wiki.dragino.com/xwiki/bin/view/Main/UART%20Access%20for%20LoRa%20ST%20v4%20base%20model/#H1.LoRaSTv4baseHardware>)

### 7.3 How to change the LoRa Frequency Bands/Region?

You can follow the instructions for how to upgrade image ([/xwiki/bin/view/Main/Firmware%20Upgrade%20Instruction%20for%20STM32%20base%20products/](http://wiki.dragino.com/xwiki/bin/view/Main/Firmware%20Upgrade%20Instruction%20for%20STM32%20base%20products/)).  
When downloading the images, choose the required image file for download.

## 8. Order Info

**Part Number: SDI-12-LB-XXX**

XXX: The default frequency band

**AS923:** LoRaWAN AS923 band

**AU915:** LoRaWAN AU915 band

**EU433:** LoRaWAN EU433 band

**EU868:** LoRaWAN EU868 band

**KR920:** LoRaWAN KR920 band



**US915:** LoRaWAN US915 band

**IN865:** LoRaWAN IN865 band

**CN470:** LoRaWAN CN470 band

## 9. Packing Info

### Package Includes:

- SDI-12-LB SDI-12 to LoRaWAN Converter x 1

### Dimension and weight:

- Device Size: cm
- Device Weight: g
- Package Size / pcs : cm
- Weight / pcs : g

## 10. Support

- Support is provided Monday to Friday, from 09:00 to 18:00 GMT+8. Due to different timezones we cannot offer live support. However, your questions will be answered as soon as possible in the before-mentioned schedule.
- Provide as much information as possible regarding your enquiry (product models, accurately describe your problem and steps to replicate it etc) and send a mail to support@dragino.com (<http://.../D:%5C%E5%B8%82%E5%9C%BA%E8%B5%84%E6%96%99%5C%E8%AF%B4%E6%98%8E%E4%B9%A6%5C%5CLoRa%5CLT%E7%B3%BB%E5%88%97%5Csupport@dragino.com>)



Tags:

Created by Xiaoling (/xwiki/bin/view/XWiki/Xiaoling) on 2023/01/30 10:48

No comments for this page