

**DEEP**Robotics

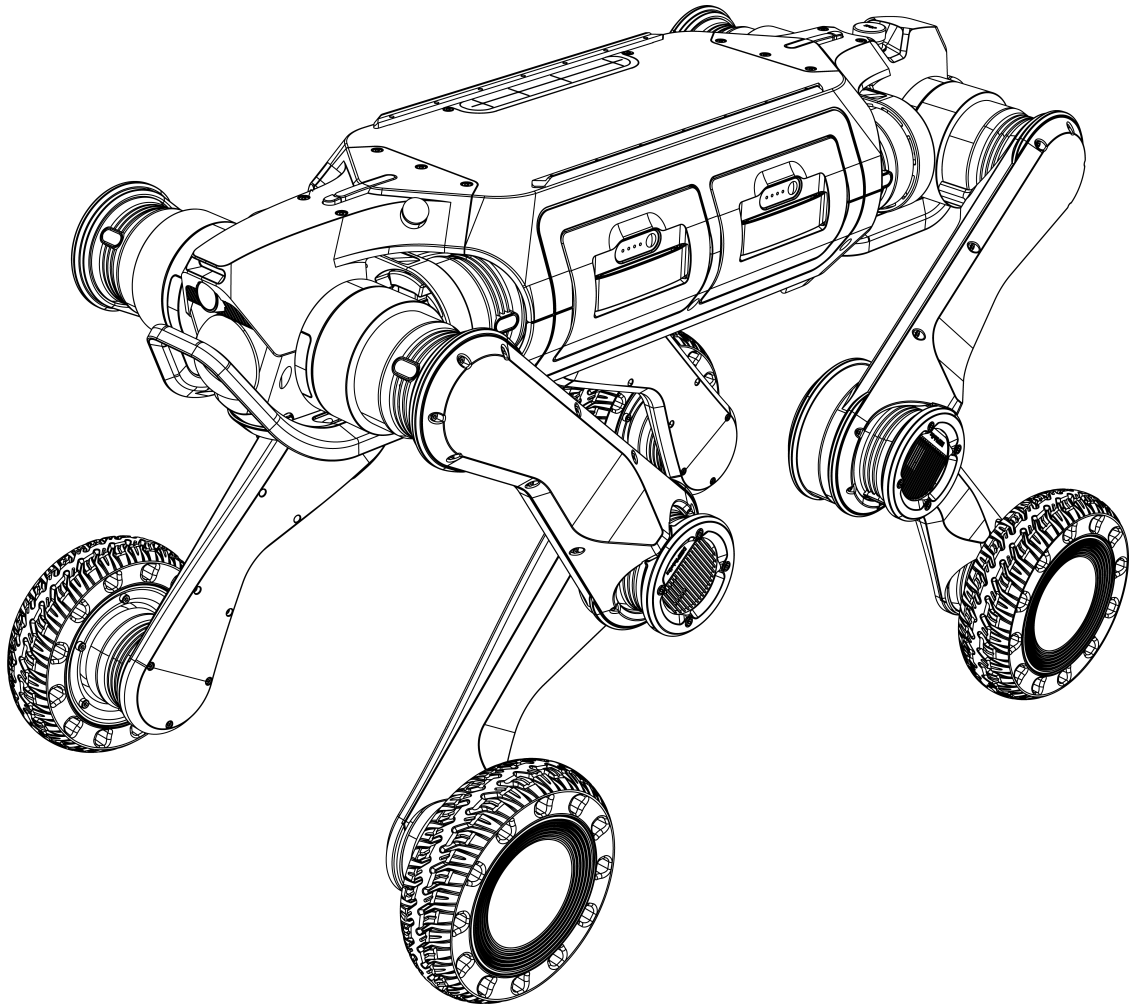

# **LYNX M20**

***Maintenance and Service Manual***  
***V0.0.2-1(2025.11.12)***



## Statement

- This manual is the information asset owned by Hangzhou Yunshenchu Technology Co.,Ltd. (hereafter referred to as DEEP Robotics) and any reproduction of part or all of this manual is strictly prohibited without the permission of DEEP Robotics.
- This manual explains the basic components, safety operation guidelines, inspection and maintenance, Service & Warranty of "Lynx M20". Be sure to read and understand this manual carefully before operating the robot.
- Basic information on safe use is described in detail in the "Reading Tips", so be sure to read this part thoroughly to ensure proper use.
- The diagrams and photographs in this manual are representative examples and may differ in details from the product purchased.
- This manual may be modified as appropriate for product improvements, specification changes, etc.
- The contents of this manual do not exclude the possibility of misremembering or omission.If this manual is damaged or lost or if you have questions about the contents of this manual, please contact us promptly.
- Failure caused by unauthorized disassembly or modification of the product by the customer is not covered by our warranty, see "Service & Warranty" for details.

## Reading Tips

### Description of Symbol

Before use (installation, transportation, maintenance, inspection), please be sure to read and master this manual, and familiarize yourself with the equipment and safety matters before you start using it. The safety matters in this manual are divided into three kinds: "Caution", "Mandatory" and "Prohibition". Even the contents of "Caution" may have serious consequences depending on the situation, so any of these safety matters are extremely important and should be strictly observed.

- |   |                    |  |
|---|--------------------|--|
|  | <b>Caution</b>     | Usage tips or operational recommendations. Improper using or operating the robot may cause damage to it. |
|  | <b>Mandatory</b>   | Matters that must be observed.   |
|  | <b>Prohibition</b> | Matters prohibited. Misoperation is dangerous and may cause injury to operators or damage to the robot.  |

### Get Help

For more resources to assist you in using Lynx M20 proficiently, you can also visit DEEP Robotics' corporate website: <https://www.deeprobotics.cn>.

# Content

<b>1 Introduction</b>	<b>1</b>
<b>2 Safety Operating Condition Requirements</b>	<b>1</b>
2.1 Operational Requirements	1
2.2 Working Environment Requirements	1
2.3 Operational Precautions	1
<b>3. Inspection and Maintenance</b>	<b>2</b>
3.1 Inspection Work	2
3.2 Maintenance	2
3.2.1 Main components	2
3.2.2 Maintenance Operations	3
3.2.3 Maintenance Cycle	8
<b>4 Transport &amp; Storage</b>	<b>9</b>
4.1 Transportation	9
4.2 Storage	9
4.3 Carrying	9
<b>5 Service &amp; Warranty</b>	<b>11</b>
5.1 Warranty Policy	11
5.2 Warranty Coverage	11
5.3 Repair Instructions	12

# 1 Introduction

The Maintenance and Service Manual is intended to guide users in routine maintenance and care operations, as well as provide direction for after-sales repair services. This document focuses on precautions for the daily operation of the Lynx M20 and the requirements for component maintenance procedures. Please read both the User Manual and the Maintenance and Service Manual carefully to understand safe operating requirements. If you have additional questions about maintenance, please contact DEEP Robotics for technical support.

## 2 Safety Operating Condition Requirements

### 2.1 Operational Requirements

Before using the product, please carefully read the *User Manual* and the *Maintenance and Service Manual* to prevent damage caused by improper operation.

### 2.2 Working Environment Requirements

- Before start the robot, ensure that all people or objects present are more than 2 meters away from the robot to avoid collisions.
- Please use the robot in an environment of 0°C ~40°C.
- Please do not operate the robot in environments with strong WiFi signal interference. Be sure to turn off all other WiFi signal source, and then use the joystick to operate the robot.
- Do not operate the robot in bad weather with fog, snow, lightning, sandstorms, windstorms, tornadoes, etc.
- Keep the robot in sight and keep it at least 2 meters away from people, water, open flames, etc at all times.
- Do not use robot on smooth surfaces such as ice, glass and tiles, If need to pass through smooth surfaces, please avoid violent movements to prevent the robot from slipping and falling.
- Do not run the robot on the edge of a high place to prevent it from falling from a height and causing damage.
- If operation in environments with strong electromagnetic interference is required, please consult after-sales support first.
- Ensure that the load does not exceed 15kg during movement.

### 2.3 Operational Precautions

	<ul style="list-style-type: none"> <li>• When carrying the robot, pay attention to the anti-pinch label on the robot and do not put your hands into the position where the anti-pinch label is attached!</li> <li>• Do not lift the robot while it is moving to avoid unintended movements that could cause damage to robot or injury to people!</li> </ul>
---	---

## 3. Inspection and Maintenance

Conducting pre-operation inspections and performing regular maintenance can extend product lifespan, maintain performance, and reduce safety hazards.

### 3.1 Inspection Work

Before each use, perform the following checks:

- Insert both batteries and check their charge levels. It is recommended to use the robot only when both batteries are at least 75% charged (each LED represents 25% charge).
- Ensure the emergency stop button is in a ready-to-trigger state (the hard emergency stop button is not pressed).
- Confirm no visible damage to the robot's exterior.
- Make sure the controller has sufficient battery power.

### 3.2 Maintenance

#### 3.2.1 Main components

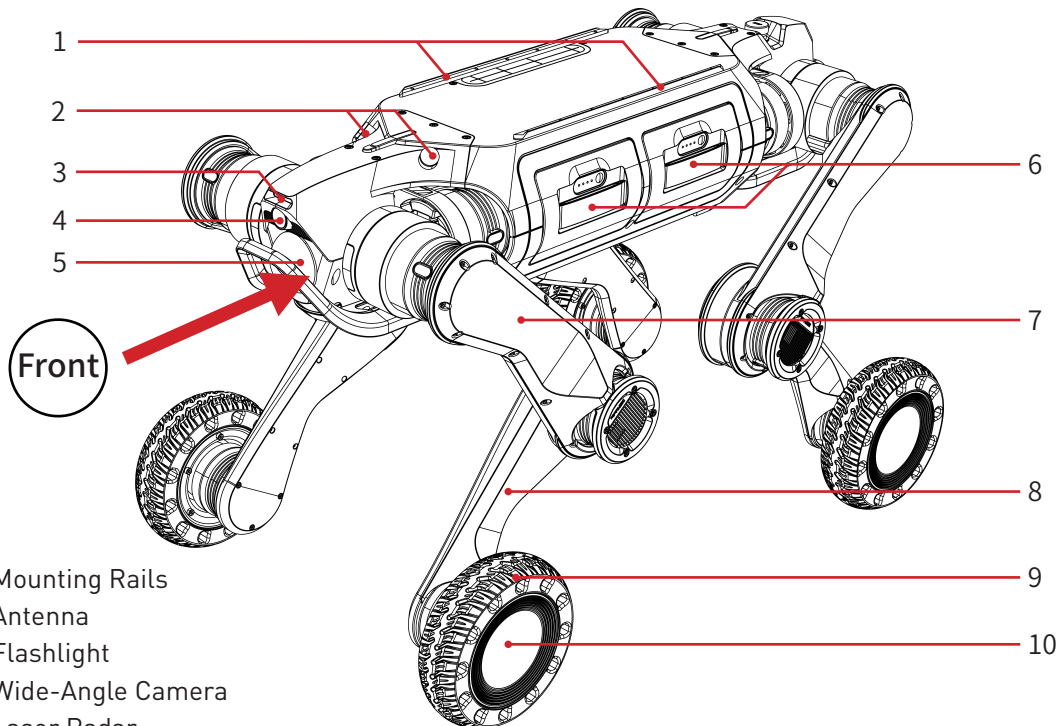

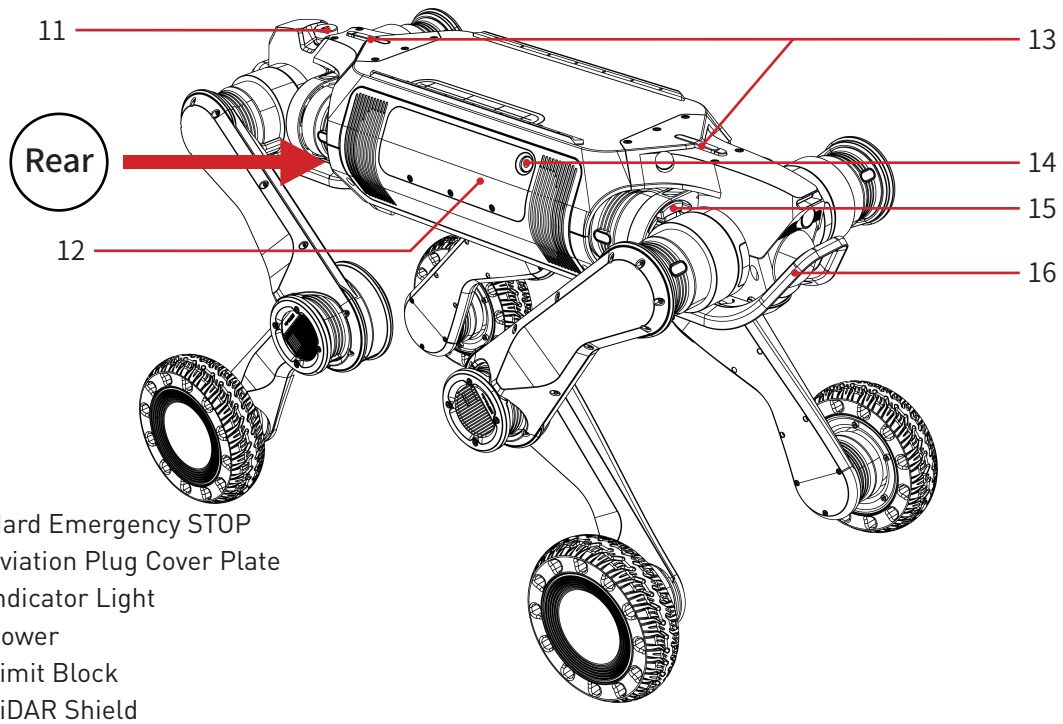









※The robot features a front–rear symmetrical design. The side with the controller’s antenna is the front of the robot, while the side with the hard emergency stop button is the rear.

### 3.2.2 Maintenance Operations

Before performing maintenance, ensure the robot's power and battery are turned off, and remove the battery from the battery compartment.

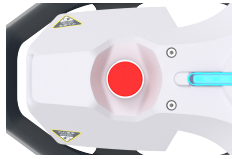
Complete Unit Part		
Robot Appearance	<ol style="list-style-type: none"> <li>1. The robot’s exterior should be clean and free from damage.</li> <li>2. Use a clean, soft cloth or a non-abrasive cotton cloth to wipe the body, paying particular attention to the LiDAR and wide-angle cameras.</li> </ol>	
Robot Screws	<ol style="list-style-type: none"> <li>1. Ensure that all screws on the robot are secure and not loose or missing, with particular attention to the motor joints.</li> <li>2. When tightening hex screws, make sure the tool is fully aligned with the screw head, inserted vertically to the bottom, and tightened with appropriate torque to avoid stripping the screw head.</li> </ol>	

Component Cleaning and Maintenance		
<p>LiDAR</p>	<ol style="list-style-type: none"> <li>1. Use a cotton cloth to gently wipe away any dust or stains on the LiDAR surface.</li> <li>2. Repeat the above step until all LiDAR sensors have been cleaned.</li> </ol>	
<p>Wide-angle Camera</p>	<ol style="list-style-type: none"> <li>1. Use a cotton cloth to gently wipe away any dust or stains on the camera surface.</li> <li>2. Repeat the above step until all camera have been cleaned.</li> </ol>	
<p>Leg Joints</p>	<ol style="list-style-type: none"> <li>1. Inspect the tightness of all joint screws and other fasteners. If necessary, use a hex wrench to tighten or adjust them to ensure the stability of the device.</li> </ol>	
<p>Battery Interface/ Battery Bin Interface</p>	<ol style="list-style-type: none"> <li>1. Inspect the battery and battery bin connectors on both the front and rear sides for corrosion, damage, or loose connections. Pay particular attention to the metal contact points.</li> <li>2. Inspect the rectangular foolproof device to ensure it is undamaged and the pins are not deformed.</li> </ol>	<div style="display: flex; justify-content: space-around;"> <div style="text-align: center;">  <p>Battery Interface</p> </div> <div style="text-align: center;">  <p>Battery Bin Interface</p> </div> </div>

Component Cleaning and Maintenance		
<p>Operation Buttons</p>	<ol style="list-style-type: none"> <li>1. Inspect the battery button, power button, and hard emergency stop button.</li> <li>2. Check the appearance to ensure the buttons are not deformed or damaged.</li> <li>3. For the power and hard emergency stop button: press and release each button two times in succession to check for any rebound issues. For the battery button: short-press it and verify that the battery indicator lights correctly display the battery level.</li> </ol>	 <p>Hard Emergency STOP Button</p>  <p>Power Button</p>  <p>Battery Button</p>
<p>Antenna</p>	<ol style="list-style-type: none"> <li>1. Inspect and clean the connection ports, ensuring the antenna connectors are neither loose nor corroded.</li> <li>2. Verify that the antenna is securely attached to the device.</li> <li>3. Check whether the antenna is broken or missing.</li> </ol>	
<p>Aviation Plug</p>	<ol style="list-style-type: none"> <li>1. Use an M3 hex key to remove the three M3 hex socket screws securing the aviation plugs cover plate, then remove the cover plate.</li> <li>2. Open the unused aviation plug covers and check whether the plugs are secure, ensuring that they are neither loose nor corroded.</li> <li>3. Replace the covers on the unused aviation plugs, reinstall the cover plate, and use the M3 hex key to tighten the three M3 hex socket screws securing the cover plate.</li> </ol>	 <p>DEEPRobotics 云深处科技</p>

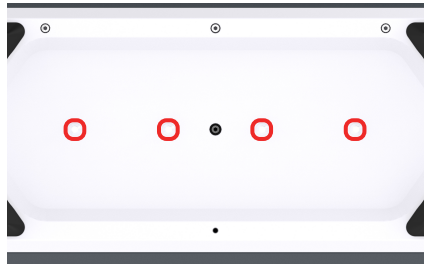
Component Cleaning and Maintenance		
<p>Controller</p>	<ol style="list-style-type: none"> <li>1. Avoid exposing the controller to liquids or food to prevent liquids from entering internal components.</li> <li>2. Do not operate the controller with excessive force to prevent undue wear on buttons and joysticks.</li> <li>3. Inspect the controller for issues such as button sticking or joystick malfunction.</li> <li>4. Check if the controller antenna is broken or missing.</li> <li>5. Verify if the controller experiences charging difficulties or fails to charge fully.</li> </ol>	
<p>Charging contacts</p>	<ol style="list-style-type: none"> <li>1. Check whether the four charging contacts on the underside of the robot show any signs of oxidation or aging.</li> <li>2. If so, use coarse sandpaper to polish off the aged layer on the contacts.</li> </ol>	

※Joint disassembly and assembly involve marking and zeroing. Please contact after-sales service before disassembly or assembly.

※One antenna is located inside the aviation plug compartment. Refer to the aviation plug maintenance procedure to remove and install the aviation plug cover plate for antenna maintenance.

Replacement of wear parts and cosmetic parts		
<p>Tire</p>	<ol style="list-style-type: none"> <li>1. Inspect for severe wear that has caused tread loss, cracks, or loss of elasticity.</li> <li>2. Prepare tools: M4 hex key; Materials: Tire*4, M4*12 hex socket screw with thread sealant*24.</li> <li>3. Unscrew the M4×12 hex socket screws securing the inner and outer wheel hubs.</li> <li>4. Mount the new tire on the outer wheel hub and fasten the inner and outer wheel hubs together with the M4 hex key.</li> </ol>	

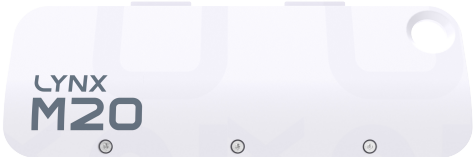
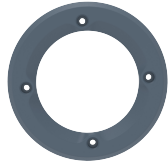
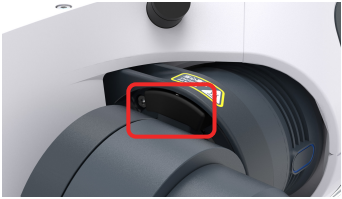
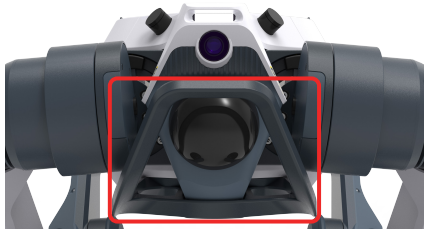
Replacement of wear parts and cosmetic parts		
<p>Outer Wheel Hub</p>	<ol style="list-style-type: none"> <li>1. Inspect for severe wear that has caused tread loss, cracks, or loss of elasticity.</li> <li>2. Prepare tools: M4 hex wrench; Materials: Tire*4, M4*12 hex socket screw with thread sealant*24.</li> <li>3. Unscrew the M4×12 hex socket screws securing the inner and outer wheel hubs.</li> <li>4. Mount the tire on the new outer wheel hub and fasten the inner and outer wheel hubs together with the M4 hex key.</li> </ol>	
<p>Aviation Plugs Cover Plate</p>	<ol style="list-style-type: none"> <li>1. Inspect for damage, cracks, or detachment.</li> </ol>	
<p>Cover</p>	<ol style="list-style-type: none"> <li>1. Avoid excessive stretching or squeezing of the protective cover to prevent deformation or damage.</li> <li>2. Inspect for cracks, tears, or severe wear.</li> </ol>	 <p>Knee Joint Cover</p>
<p>Limit Block</p>	<ol style="list-style-type: none"> <li>1. Inspect whether the limit block has any cracks or damage.</li> </ol>	
<p>LiDAR Shield</p>	<ol style="list-style-type: none"> <li>1. Inspect for rust or corrosion.</li> <li>2. Inspect for severe deformation.</li> </ol>	

※For outer wheel hub replacement, please refer to the tire replacement diagram.

※If you encounter any issues, please contact after-sales service for evaluation.

### 3.2.3 Maintenance Cycle

Maintenance Cycle	
LiDAR	3–6 weeks (depending on specific operating conditions)
Wide-angle Camera	3–6 weeks (depending on specific operating conditions)
Charging Contacts	6 weeks (depending on specific operating conditions)
Tire	3–6 months (depending on specific operating conditions)
Wheel Hub	3–6 months (depending on specific operating conditions)
Battery Interface / Battery Bin Interface	Inspect before use
Antenna	3 months (depending on specific operating conditions)
Aviation Plugs	3 months (depending on specific operating conditions)
Controller	3 months (depending on specific operating conditions)
Aviation Plugs Cover Plate	- (depending on specific operating conditions)
Cover	- (depending on specific operating conditions)
Limit Block	- (depending on specific operating conditions)
LiDAR Shield	- (depending on specific operating conditions)
Leg Joint	3 months (depending on specific operating conditions)
Operation Button	- (depending on specific operating conditions)

## 4 Transport & Storage

### 4.1 Transportation

When transporting the Lynx M20, please use the transport case specifically designed for it.

	<p>Before shipping the robot with transport case, remove the batteries from the robot. And when shipping, make sure the front of the transport case is facing up.</p>
---	---

### 4.2 Storage

- Lynx M20 requires a clean and dry storage environment of 0°C ~40°C .
- Robot power must be off.
- Do not allow water or other liquids to drench the robot.
- It is strictly forbidden to place other objects within the joint rotation range.
- It is recommended to store Lynx M20 in the transport case specifically designed for it to protect it from shock and vibration.
- Lynx M20 must be placed in the transport case with its back facing up.
- If not in use for a long time, please remove the battery from the robot, store it separately and charge it to 60%, so as to avoid over-discharging of the battery, which may cause damage to the battery cell and make it impossible to continue to use.

### 4.3 Carrying

Lynx M20 weights approximately 35kg and it is recommended that two people carry it: One person stands at the front of the robot, firmly gripping both the lower and upper legs on each side with both hands; another person stands at the rear of the robot and adopts the same method to assist in completing the carrying task.

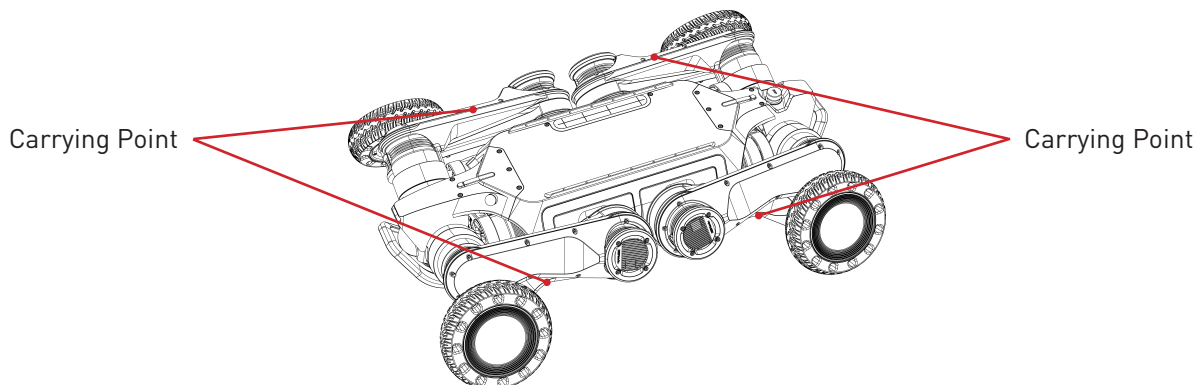



- Power off Lynx M20 and carry it gently.
- Keep your hands away from easy pinch points and the range of motion of joints prevent pinching or scratching.
- The metal components of the robot's legs that have just finished running are hot, so please wait until it cools down to suitable temperature before carrying.

The robot's high temperature and pinch points are shown in the figure below:

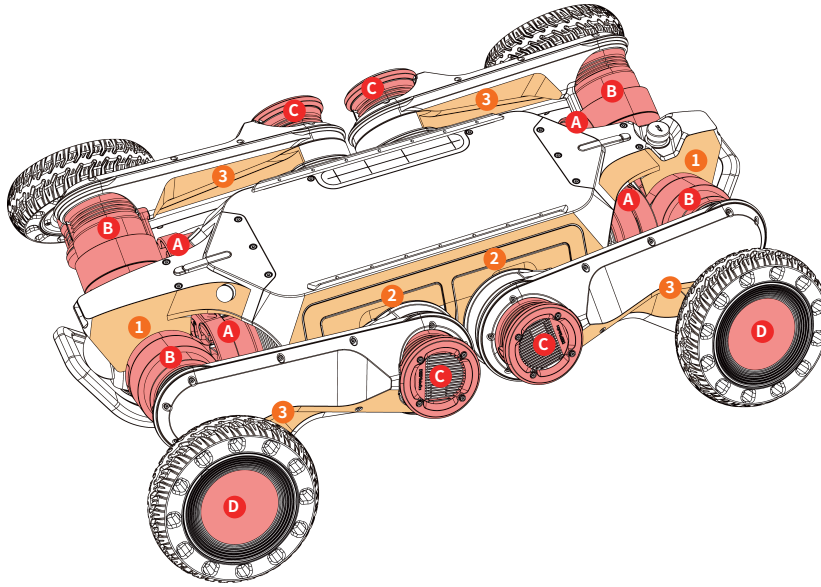

※Red letters indicate areas prone to high temperatures, and orange numbers mark easy pinch points.

※① , ② , ③ correspond to the HipX, HipY, and Knee joints, respectively. ④ indicates the hub surface connected to the wheel joint. These areas, especially the joint modules and surrounding metal parts, may become hot after operation, DO NOT TOUCH!

※① : Gap between the shell of the head/tail and the adjacent joint. ② : Gap between the lower leg and the body side cover. ③ : Gap between the upper and lower leg.

※ Note: Pinch points on the right side of the robot are not fully marked in the diagram. However, since the robot is symmetrically designed, the right side mirrors the left.

※ The pinch points listed above are not exhaustive. Exercise caution when carrying the robot.

## 5 Service & Warranty

### 5.1 Warranty Policy

The warranty period for the major components of Lynx M20 is as below.

Component Name	Warranty Period
Joint Module	Six Months
Replaceable Battery, Wide Angle Camera, Laser Rader, Control System, Other Electronic Components	One year

**Tip: Shell, tyre and other fragile parts, and transport case and other accessories are not covered by warranty. If necessary, please consult after-sales support.**

The warranty period starts from the date of receipt. Products or parts that meet the warranty period and the contents of the warranty will receive free after-sales service. If the product you purchased is beyond the warranty period, you can also get help from us by purchasing a separate service.

### 5.2 Warranty Coverage

Depending on the specific situation, we will repair or replace parts accordingly for the product you purchased. However, the following cases will not be covered by the free warranty, but you can still choose to have paid after-sales service, for which please consult the after-sales support for details.

- Damage caused by man-made non-product quality problems.
- Unauthorized modification, disassembly, shell opening, etc.
- Out of warranty.
- Damage caused by improper installation, use and operation (such as dropping, crushing, immersion, violent use, etc.) as required by the manual.
- Damage caused by use in excess of the safe weight capacity.
- Damage caused by self-repair or replacement of parts without official instructions.
- Damage caused by installing third-party products by yourself.
- Damage caused by the use of a non-original battery pack for power supply.
- Failure or damage due to force majeure factors such as typhoon, earthquake, fire, lightning strike, abnormal voltage.
- Damage caused by operating the robot in an environment with severe signal interference.
- Damage caused by improper handling of the robot on slippery surfaces such as glass and ice.
- Fallen damage caused by the use of a robot near a high edge.
- Fallen damage other than operate the robot on flat terrain.

- Damage caused by operation in environments such as sharp terrain and large undulations.
- Damage caused by forced operation of parts in the event of aging or damage.
- Damage caused by not keeping a safe distance when used in complex environments.
- There are obvious traces of dust, grit, water, and metal powder intrusion inside the robot.
- Damage caused by improper handling operations.
- Damage caused by violent or non-violent means applied to the robot when it exceeds its anti-interference limit.
- Due to operation errors, there are obvious marks of collision and scratches on the surface of the robot.

### 5.3 Repair Instructions

- Before getting after-sales service, please make sure to backup all data and delete important data to prevent data loss or leakage. DEEP Robotics is not responsible for the loss or leakage of any data contained in the product.
- When you obtain after-sales service from DEEP Robotics, you authorize DEEP Robotics to make any modification, delete data or restore factory settings for the purpose of after-sales service.
- Before sending it for repair, please contact after-sales support, DEEP Robotics will try to diagnose and solve your problem remotely.
- If the above methods cannot solve your problem, you can send it back to the robot for repair after verifying with after-sales support. You need to pay for the postage first when you send the product to DEEP Robotics. After DEEP Robotics receives the product in need of maintenance, the product will be tested to determine the problem and responsibility.
- If the problem is caused by defects in quality of the product itself, DEEP Robotics will be responsible for the testing fee, material fee, labor fee and the postage for sending back.
- If the product does not meet the conditions of free repair, you can choose to pay for repair, and the corresponding testing fee, material fee, labor fee and the postage for sending back will be paid by you. You can also choose not to repair and to send back the product, the corresponding postage and insurance fee will be paid by you.
- Considering environmental protection and safety, please do not send back seriously damaged batteries. If you have sent back, DEEP Robotics will scrap such batteries and will not return them back.
- If you provide an incorrect delivery address which results in non-delivery or rejection by the recipient, the adverse consequences and losses shall be afforded by you.
- To ensure your rights and interests, when you sign for the after-sale products sent by DEEP Robotics, please check carefully whether the products are intact. If there is any abnormality, please immediately take video or photos on the spot and contact DEEP

Robotics to get the solution. If there are unresolved after-sale problems, please also contact DEEP Robotics immediately, otherwise it is regarded as the end of this after-sale service without dispute.

- ※The final interpretation of these after-sales terms and conditions belongs to DEEP Robotics.
- ※Please contact us if you have any questions before obtaining after-sales service.
- ※These after-sales terms and conditions are only used in Chinese mainland, and the after-sales policies of other countries or regions are subject to local laws.

# DEEP Robotics

Hangzhou Yunshenchu Technology Co.,Ltd.

ADD: Building 3, Zijin Dream Plaza, No.36 Xinran Street, Sandun Town,  
Xihu District, Hangzhou, Zhejiang, China

TEL: +86 400-0559-095

WEB: [www.deeprobotics.cn](http://www.deeprobotics.cn)

