

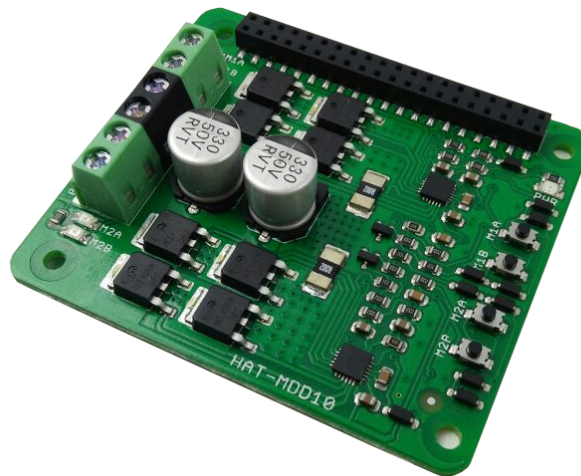

HAT-MDD10

10Amp DC Motor Driver for Raspberry Pi



User's Manual

V1.0

Mac 2017

Information contained in this publication regarding device applications and the like is intended through suggestion only and may be superseded by updates. It is your responsibility to ensure that your application meets with your specifications. No representation or warranty is given and no liability is assumed by Cytron Technologies Incorporated with respect to the accuracy or use of such information or infringement of patents or other intellectual property rights arising from such use or otherwise. Use of Cytron Technologies's products as critical components in life support systems is not authorized except with express written approval by Cytron Technologies. No licenses are conveyed, implicitly or otherwise, under any intellectual property rights.

INDEX

1. Introduction/Overview	3
2. Packing List	4
3. Board Layout	5
4. Product Specification	8
5. Dimension	9
6. Getting Started	10
7. Warranty	11

1. INTRODUCTION/OVERVIEW

[HAT-MDD10](#) is designed to drive two high current brushed DC motor up to 10A continuously by using [Raspberry Pi](#) as a controller. It offers several enhancements such as support for both locked-antiphase and sign-magnitude PWM signal as well as using full solid state components which result in faster response time and eliminate the wear and tear of the mechanical relay.

The [HAT-MDD10](#) has been designed with the capabilities and features of:

- Bi-directional control for two brushed DC motor.
- Support motor voltage ranges from **6V to 24V**.
- Maximum current up to **10A continuous** (without heatsink at 25°C) and 30A peak (10 second).
- Current limiting at **30A**.
- 3.3V and 5V logic level input.
- Raspberry Pi compatible connector.
- Manual/test button to fast verification.
- Solid state components provide faster response time and eliminate the wear and tear of mechanical relay.
- Fully NMOS H-Bridge for better efficiency and no heat sink is required.
- Speed control PWM frequency up to 20KHz (Actual output frequency is same as input frequency).
- Support both locked-antiphase and sign-magnitude PWM operation.
- Support TTL PWM from microcontroller, **not PWM from RC receiver**.
- **Dimension:**67.5mm x 59mm

2. PACKING LIST

Please check the parts and components according to the packing list. If there are any parts missing, please contact us at sales@cytron.com.my immediately.

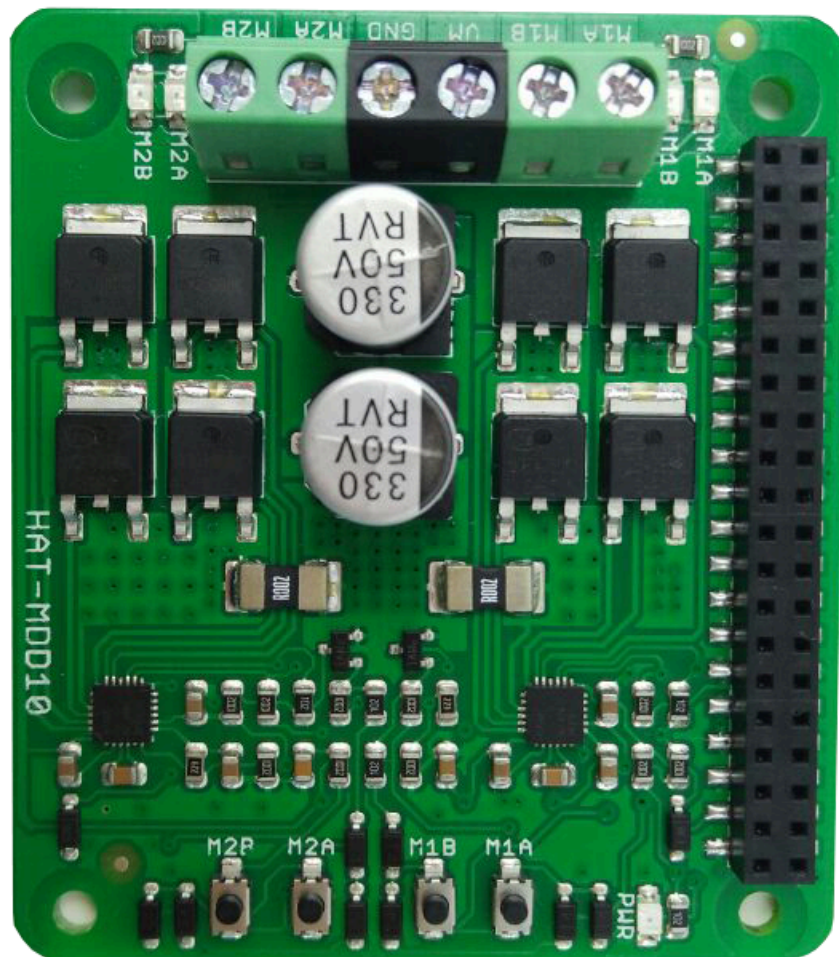

1. 1 x Hat-MDD10 10A DC Motor Driver.
2. 1 x PC104 Header Pin (2x20) (CN-PH-PC104)
3. User's manual can be downloaded from <https://www.cytron.io/p-hat-mdd10>

3. BOARD LAYOUT AND SPECIFICATION

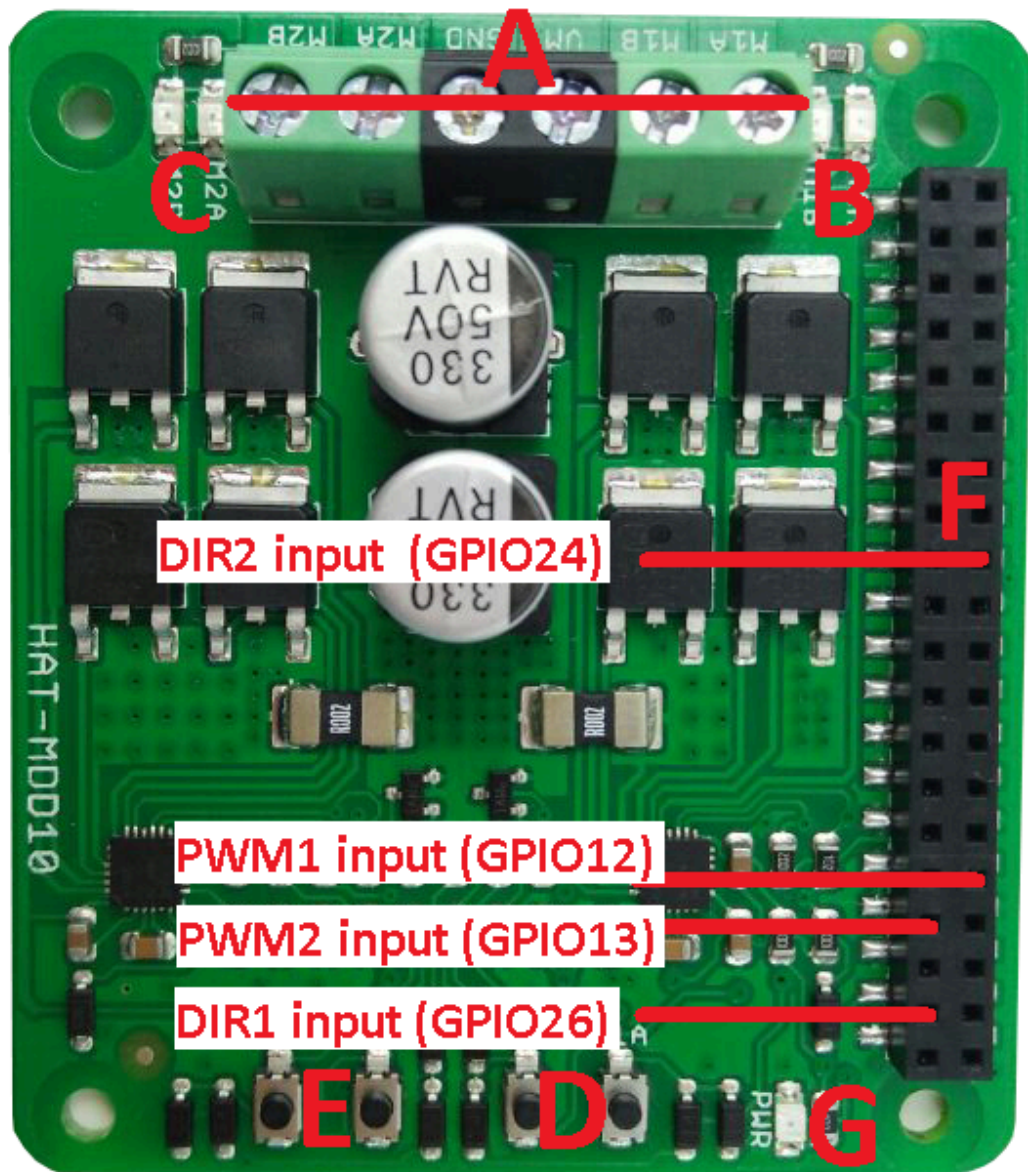

Label	Function
A	Terminal Block
B	Motor1 LED Indicator
C	Motor2 LED Indicator
D	Motor1 Test Switch
E	Motor2 Test Switch

F	Raspberry Pie Connector
G	Power LED Indicator
H	PWM1 input (GPIO12)
I	DIR1 input (GPIO26)
J	PWM2 input (GPIO13)
K	DIR2 input (GPIO24)

1. Terminal Block – Connect to motor and power source.

	Pin Name	Description
1	M1A	Connect to motor1 terminal A
2	M1B	Connect to motor1 terminal B
3	VM	Positive Supply (6V to 24V ^{*1})
4	GND	Negative Supply
5	M2A	Connect to motor2 terminal A
6	M2B	Connect to motor2 terminal B

^{*1}: Absolute Maximum

2. M1A/M2A LED Indicator – Turns on when the output A is high and output B is low. Indicates the current flows from output A to B.

3. M1B/M2B LED Indicator – Turns on when the output A is low and output B is high. Indicates the current flows from output B to A.

4. M1A/M2A Test Switch – When this button is pressed, current flows from output A to B and motor will turn CW (or CCW depending on the connection).

5. M1B/M2B Test Switch – When this button is pressed, current flows from output B to A and motor will turn CCW (or CW depending on the connection).

6. Input

.	Pin Name	Description
1	GND	Logic ground.
2	**PWM1 (GPIO12)	PWM input for motor 1 speed control
3	DIR1 (GPIO26)	Direction control for motor 1.

4	**PWM2 (GPIO13)	PWM input for motor 2 speed control
5	DIR2 (GPIO24)	Direction control for motor 2.

****Note that it is not for RC PWM operation**

The truth table for the control logic is as follow:

Pin PWM	Pin DIR	Output A	Output B
Low	X (Don't care)	Low	Low
High	Low	High	Low
High	High	Low	High

7. Power LED Indicator – Power LED. Should be on when the board is powered on.

4. PRODUCT SPECIFICATION AND LIMITATIONS

Absolute Maximum Rating

No.	Parameters	Min	Typical	Max	Unit
1	Power Input Voltage	6	-	24	V
2	I_{MAX} (Maximum Continuous Motor Current)	-	-	10	A
3	I_{PEAK} – (Peak Motor Current) *	-	-	30	A
4	V_{IOH} (Logic Input – High Level)	3	-	5.5	V
5	V_{IOL} (Logic Input – Low Level)	0	0	0.5	V
6	Maximum PWM Frequency **	-	-	20	KHz

* **Must not exceed 10 seconds.**

** **Actual output frequency is same as input frequency.**

*** **Tested in room temperature.**

5. DIMENSION

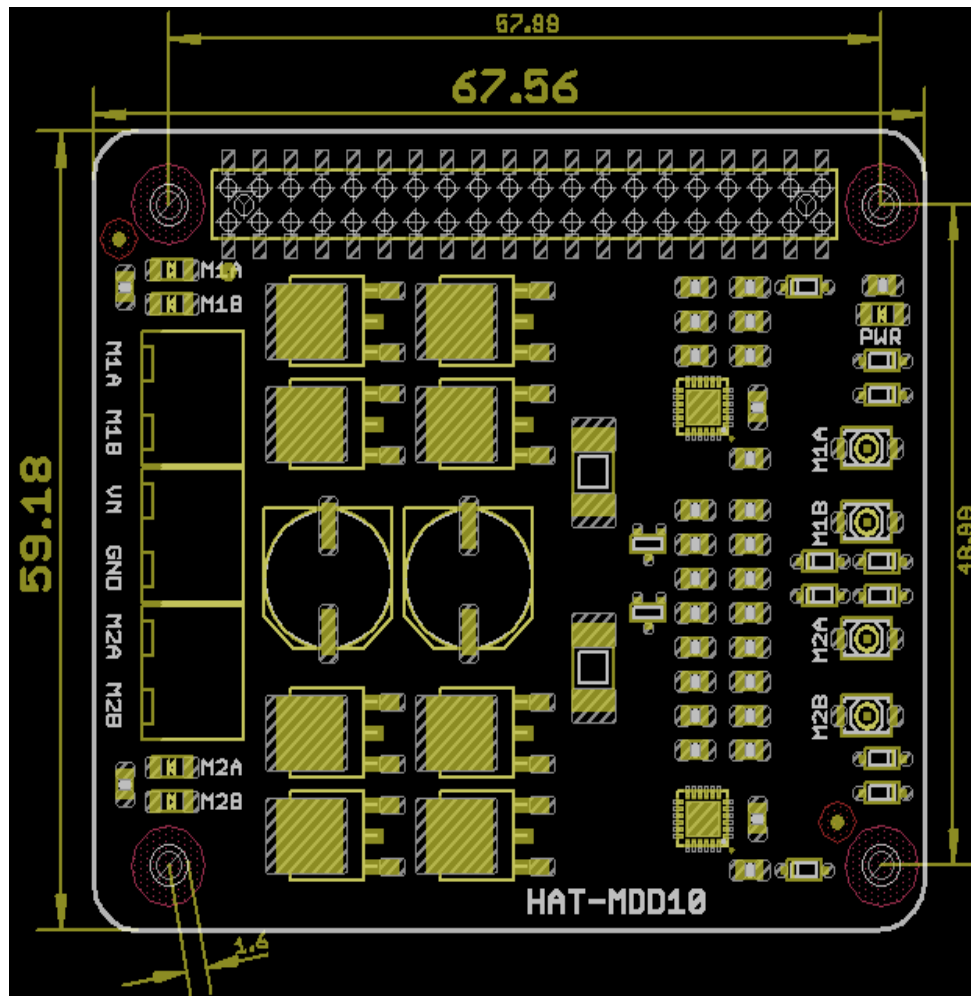

Footprint Dimension

6. GETTING STARTED

Hat-MDD10 is compatible with 2 types of PWM operation, which are:

1. Sign-Magnitude PWM – For sign-magnitude PWM operation, 2 different control signals are used to control the speed and direction of the motor. PWM is feed to the PWM pin to control the speed while DIR pin is used to control the direction of the motor.
2. Locked-Antiphase PWM – For locked-antiphase PWM operation, only 1 control signal is needed to control the speed and direction of the motor, while another input is to enable the driver. PWM pin is connected to logic high while the DIR pin is being feed with the PWM signal. When the PWM signal has 50% duty cycle, the motor stops running. If the PWM has less than 50% duty cycle, the motor will turn CW (or CCW depending on the connection). If the PWM signal has more than 50% duty cycle, motor will turn CCW (or CW depending on the connection).

Sample connection diagram is as follow:

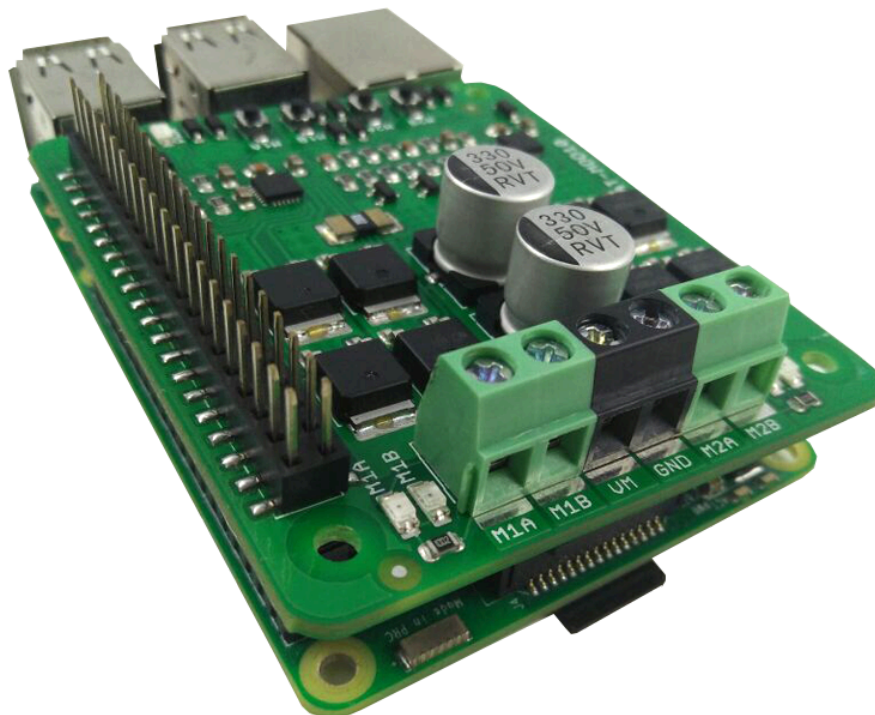

6. WARRANTY

- Product warranty is valid for 12 months.
- Warranty only applies to manufacturing defect.
- Damaged caused by misuse is not covered under warranty
- Warranty does not cover freight cost for both ways.

Prepared by:

Cytron Technologies Sdn. Bhd.

No. 1, Lorong Industri Impian 1,
Taman Industri Impian,
14000 Bukit Mertajam,
Pulau Pinang, Malaysia.

Tel: +604-548 0668

Fax: +604-548 0669

URL: www.cytron.io

Email: support@cytron.io
sales@cytron.io