

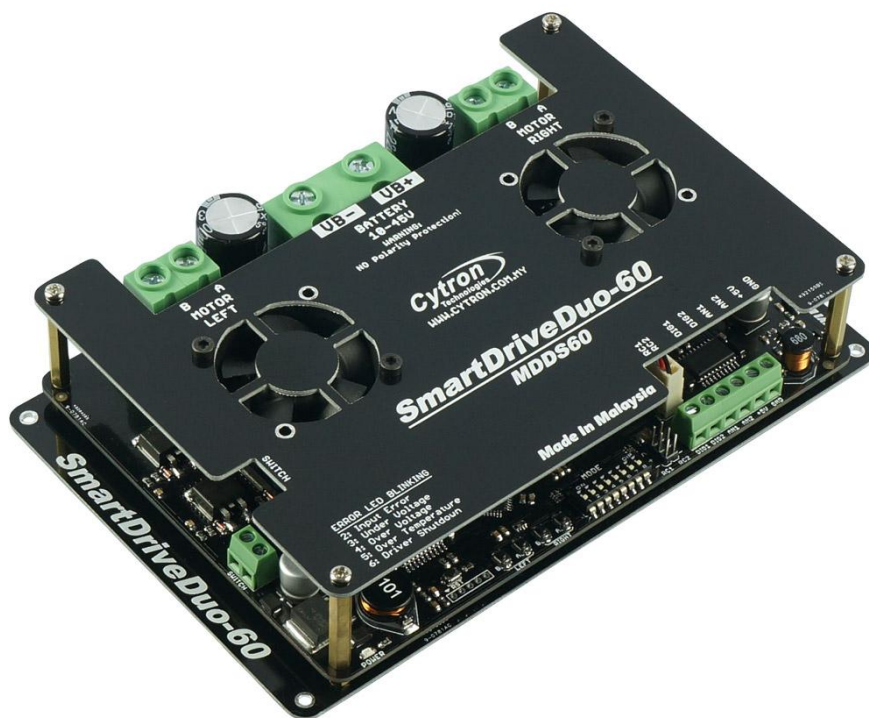

## SmartDriveDuo-60 MDDS60



## User's Manual

Rev 1.1

July 2019

Information contained in this publication regarding device applications and the like is intended through suggestion only and may be superseded by updates. It is your responsibility to ensure that your application meets with your specifications. No representation or warranty is given and no liability is assumed by Cytron Technologies Incorporated with respect to the accuracy or use of such information or infringement of patents or other intellectual property rights arising from such use or otherwise. Use of Cytron Technologies's products as critical components in life support systems is not authorized except with express written approval by Cytron Technologies. No licenses are conveyed, implicitly or otherwise, under any intellectual property rights.

## INDEX

1. <a href="#">Introduction</a>	3
2. <a href="#">Packing List</a>	4
3. <a href="#">Product Specifications</a>	5
4. <a href="#">Board Layout</a>	6
5. <a href="#">Power Supply</a>	9
6. <a href="#">Motor Connection</a>	10
7. <a href="#">Hardware setup for external Power Switch</a>	11
8. <a href="#">Safety Features</a>	13
9. <a href="#">Input Modes</a>	15
a. <a href="#">RC Input Mode</a>	17
b. <a href="#">Analog/PWM Input Mode</a>	20
c. <a href="#">Simplified Serial Mode</a>	24
d. <a href="#">Packetized Serial Mode</a>	26
10. <a href="#">Warranty</a>	28

## 1. INTRODUCTION

SmartDriveDuo-60 is one of the latest smart series motor drivers designed to drive medium power brushed DC motor with current capacity up to 100A peak (few seconds) and 60A continuously, each channel. This driver is designed specially for controlling differential drive mobile robot using RC controller. Nevertheless, MDDS60 also can be controlled using analog joystick or microcontroller (PWM, Serial). MOSFETs are switched at 16 KHz to ensure quiet operation and no annoying whining sound. Besides, it also equipped with a microcontroller unit to provide smart features such as multiple input mode and thermal protection.

SmartDriveDuo-60's feature makes driving a robot with differential drive a truly plug and play experience.

Some of the features for SmartDriveDuo-60 are summarized as below:

- Bi-directional control for dual brushed DC motor.
- Support motor voltage from 10V to 45V.
- Maximum current up to 100A peak (1 second), 60A continuously, each channel.
- On board MOSFETs are switched at 16 KHz for quiet operation.
- Battery low voltage indicator.
- Battery over voltage indicator.
- Thermal protection.
- Multiple input modes: RC, Analog, PWM, Simplified Serial and Packetized Serial.
- On board push buttons for fast test and manual operation.
- **No polarity protection for V motor.**

**Note:** MDDS60 is shipped in **Rev1.10 since January 2019**. There is a component changes on the circuit. The modification does not affect the performance or the interface.

## 2. PACKING LIST

Please check the parts and components according to the packing list. If there are any parts missing, please contact us at [sales@cytron.com.my](mailto:sales@cytron.com.my) immediately.



- 1 x [SmartDriveDuo-60](#) with top and bottom cover.
- 2 x [2561 Servo Extension cable](#)

## MDDS60 SmartDriveDuo-60 Revision



**Note:** MDDS60 is shipped in **Rev1.10** since **January 2019**. There is a component changes on the circuit. The modification does not affect the performance or the interface.

### 3. PRODUCT SPECIFICATIONS

Dimension:

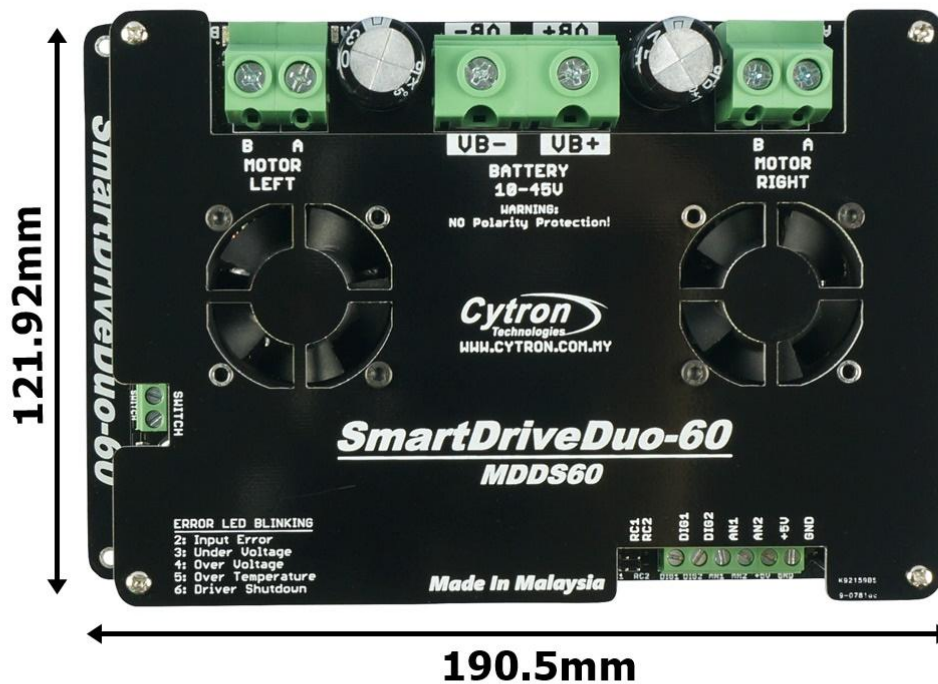

Absolute Maximum Rating of SmartDriveDuo-60

No	Parameters	Min	Typical	Max	Unit
1	Input Voltage (Motor Supply Voltage)	10	-	45	V
2	$I_{MAX}$ (Maximum Continuous Motor Current)*	-	-	60	A
3	$I_{PEAK}$ – (Peak Motor Current) **	-	-	100	A
4	$V_{IOH}$ (Logic Input – High Level)	1.3	-	5	V
5	$V_{IOL}$ (Logic Input – Low Level)	0	-	0.7	V
6	5V Output Current	-	-	500	mA

\* Depends on the room temperature.

\*\* Must not exceed 1 second.

#### 4. BOARD LAYOUT

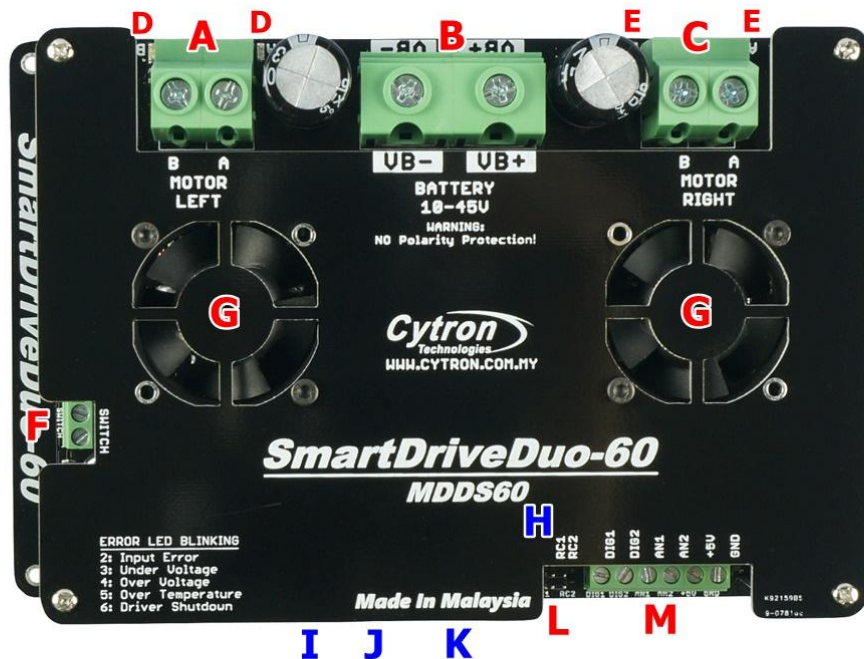

Label	Function
<b>A</b>	Motor LEFT Terminal Block
<b>B</b>	Power Supply Terminal block
<b>C</b>	Motor RIGHT Terminal Block
<b>D</b>	Motor LEFT LED Indicator
<b>E</b>	Motor RIGHT LED Indicator
<b>F</b>	Power Switch Terminal Block
<b>G</b>	Cooling Fan
<b>H</b>	Run and Error LED
<b>I</b>	Motor LEFT Test Button
<b>J</b>	Motor RIGHT Test Button
<b>K</b>	Mode Selection DIP Switch
<b>L</b>	RC Input Pin
<b>M</b>	Analog/PWM/Serial Input Terminal Block

\*Note: For **BLUE** font, the component is located at middle board.

## **FUNCTION Description:**

### **Motor LEFT Terminal Block**

Connect to motor LEFT at your mobile robot. User can screw to lock the wire to the terminal block or solder the wire directly to the pad at bottom layer. Please use wire with proper thickness to support the expected current.

### **Power Supply Terminal Block**

Connect to power source. User can screw to lock the wire to the terminal block or solder the wire directly to the pad at bottom layer. **No polarity protection**, please double check before power up. Please use wire with proper thickness to support the expected current.

### **Motor RIGHT Terminal Block**

Connect to motor RIGHT at your mobile robot. User can screw to lock the wire to the terminal block or solder the wire directly to the pad at bottom layer. Please use wire with proper thickness to support the expected current.

### **Motor LEFT LED Indicator**

Indication for current flow and direction for motor LEFT. If LED MLA turns on, means current flows from output MLA to MLB. Vice versa.

### **Motor RIGHT LED Indicator**

Indication for current flow and direction for motor RIGHT. If LED MRA turns on, means current flows from output MRA to MRB. Vice versa.

### **Power Switch Terminal Block**

Switch for power up MDDS60's microcontroller and logic circuit. This switch is ON by default. User need to cut the PCB track at the bottom layer of PCB to utilize this terminal.

### **Cooling Fan**

Once MDDS60 is powered up, this fan will blow the board.

### **Run and Error LED**

RUN\_L: Turns on when motor LEFT is running. If signal error received for motor LEFT, it will blink.

RUN\_R: Turns on when motor RIGHT is running. If signal error received for motor RIGHT, it will blink.

**Error LED**

Number of Blinks	Error	Description
Off	No Error	No error has been detected.
2	Input Error	Invalid or no input detected.
3	Under Voltage	The battery voltage is low.
4	Over Voltage	Supply voltage is over the limit. MDDS60 will not operate.
5	Over Temperature	Board temperature is high.
6	Shutdown	Board temperature is too high! Motor automatically stop.

**Motor LEFT Test Button**

Fast test to check driver functionality for motor LEFT. If A is pressed, current flows from output A to B. Vice Versa.

**Motor RIGHT Test Button**

Fast test to check driver functionality for motor RIGHT. If A is pressed, current flows from output A to B. Vice Versa.

**Mode Selection DIP Switch**

User can select different input mode by setting the DIP switch.

**RC Input Pin**

This pins specially for RC receiver input wire. RC1 for forward/reverse and RC2 for steering.

**Analog/PWM/Serial Input Terminal Block**

No	Pin Name	Description
1	DIG1*	1: Digital signal (Direction) for motor LEFT. 2: Serial Simplified, Serial Packetized.
2	DIG2	Digital signal (Direction) for motor RIGHT.
3	AN1	Analog/PWM signal for motor LEFT.
4	AN2	Analog/PWM signal for motor RIGHT.
5	+5V	+5V output. <b>Do not</b> connect to another 5V source.
6	GND	Ground.

\*DIG1 can accept 2 types of input.

\*\*Please refer to INPUT MODE section for more detail.



## 5. POWER SUPPLY

SmartDriveDuo-60 supports input voltage ranges from 10V to 45V. The recommended power sources are:

- 6 – 18 cells NiMH or NiCd battery.
- 3 – 6 cells LiPo or Li-Ion battery.
- 10V – 45V sealed lead acid battery.
- 10V – 45V power supply (**Must be in parallel with a battery with same voltage**).

The power source can be connected to SmartDriveDuo-60 either via the terminal block, or soldered directly to the pad at the bottom layer. **There is no polarity protection on MDDS60, please double check the connection before connecting to power source.**

### **NOTE:**

1. If a power supply that cannot sink current is being used (example: bench top and AC to DC switching power supply), the input voltage will rise when the driver is regenerating (motor is slowing down). Thus, it is important to connect a battery with same voltage in parallel with the power supply to absorb the current generated by the motor. Else, the input voltage might rise to a level where SmartDriveDuo-60 will be destroyed permanently or the power supply trigger protection mode.

## 6. MOTOR CONNECTION

Similar to the power supply, connection to the motor can be made either via the terminal block, or it can be soldered directly to the bottom layer pad.

For Mixed mode, especially for [RC input mode](#) (or [Breakout board with Joystick soldered](#)), each terminal block must be connected to the same side of the motor. For example, **left terminal block connected to motor LEFT and right terminal block connected to motor RIGHT**. User can further test it by controlling the motor by using RC controller. If the motor give wrong direction, reverse the polarity of the motor connection at the terminal block.

## 7. HARDWARE SETUP FOR EXTERNAL POWER SWITCH



As shown in the picture above, there is terminal block for external power switch. Here are the steps on how to add external power switch.

- 1) Connect Switch to the terminal block.

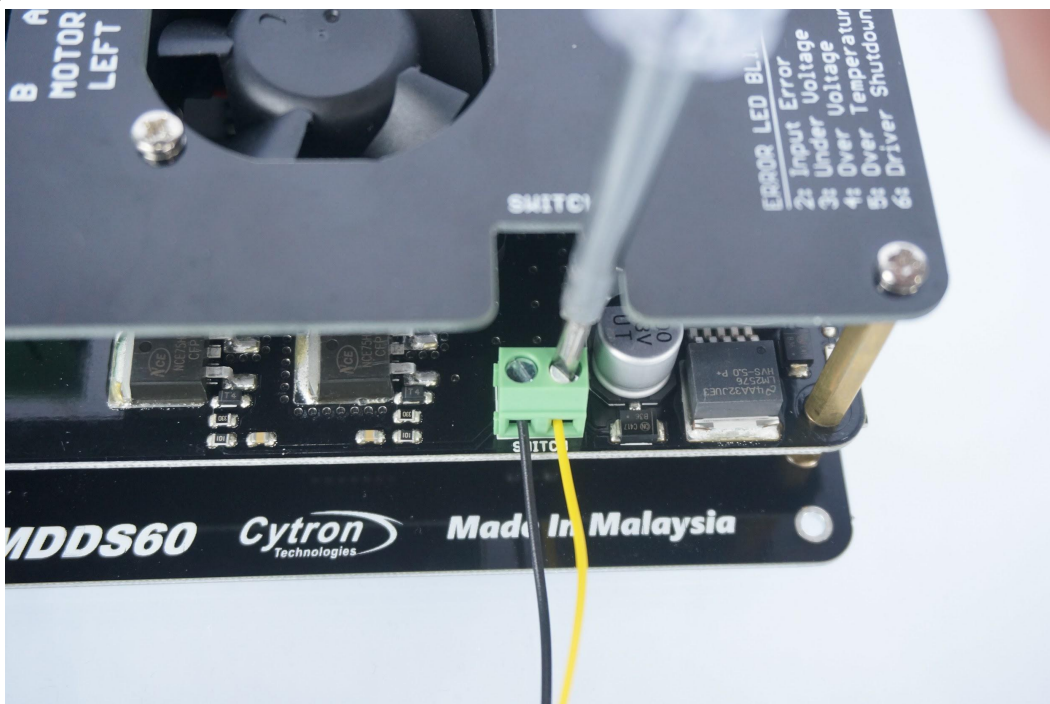

2) At the back of board under Switch terminal block, unsolder it like shown in the figure below.

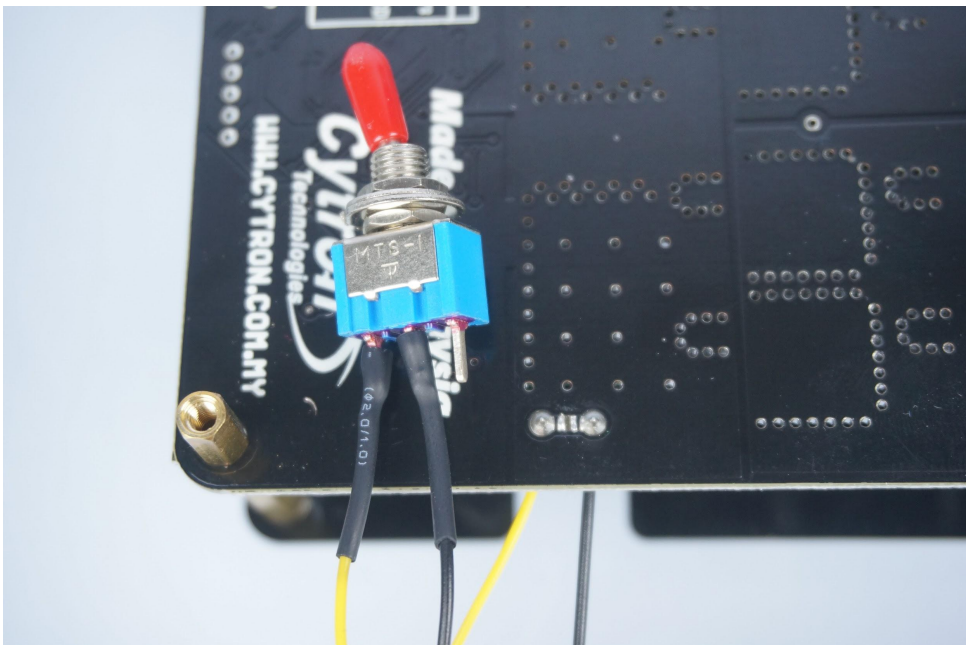
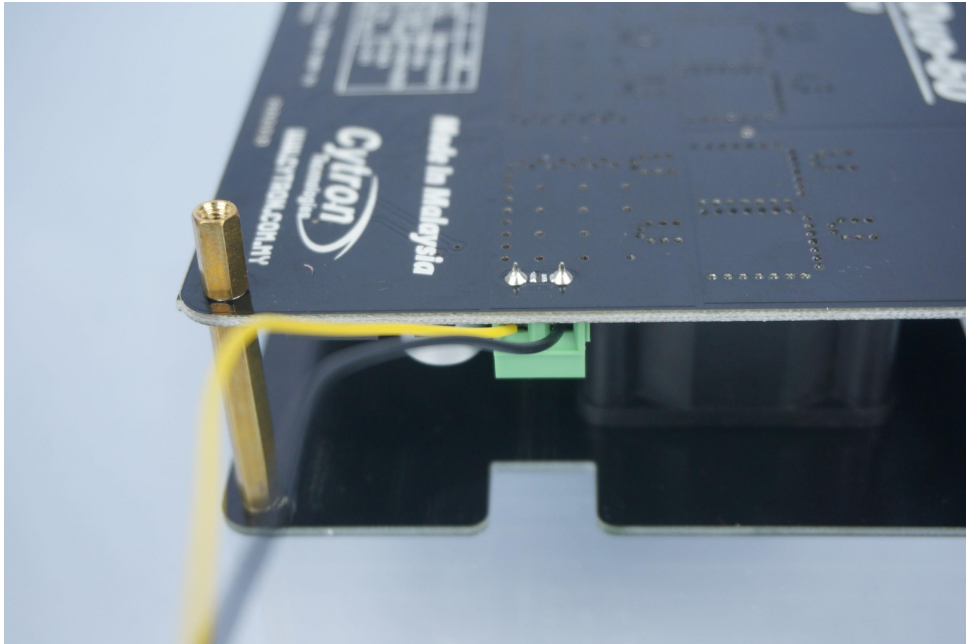

## 8. SAFETY FEATURES

SmartDriveDuo-60 incorporates some safety features which make it robust and reliable motor driver. Below are the detailed descriptions for each feature.

- a. **Input Error (Error LED blinks 2 times)**  
 Every time SmartDriveDuo-60 is power up, the input data must be 'stop' (for RC, Analog, PWM input mode). This feature prevent the driver from sudden run, especially when the driver accidently reset.
  
- b. **Under Voltage Warning (Error LED blinks 3 times)**  
 Upon power on, SmartDriveDuo-60 will automatically detect the number of cells for the battery. If it is set to LiPo, when the input voltage falls below 3.0V per cell during operation, the error LED will blink to warn the user. However, the power to the motor will be maintained and will not be cut out. Thus, it is user's responsibility to stop the motor driving and replace battery to avoid further damage to the battery. If other types of battery is used to power the board (e.g NiMH, NiCD, SLA), the under voltage warning will still be shown. In this case, user may ignore the warning and he/she needs to estimate when to replace the battery by him/herself.
  
- c. **Over Voltage Protection (Error LED blinks 4 times)**  
 If over voltage is detected (> 45V), SmartDriveDuo-60 will not operate.
  
- d. **Over Temperature Protection (Error LED blinks 5 times)**  
 SmartDriveDuo-60 is equipped with a temperature sensor to monitor its operating temperature. It will gradually lower down the duty cycle percentage base on the temperature as shown below:

Temperature Range (°C)	Duty Cycle (%)
< 50	100
50 – 55	90
55 – 60	80
60 – 65	70
65 – 70	60
70 – 80	50
80 – 85	40
85 – 90	30
90 – 95	20
95 – 100	10
100 – 105	5
> 105	0 (Shutdown)

- e. **Shutdown (Error LED blinks 6 times)**  
 Shutdown will occur when SmartDriveDuo-60 temperature become too high (temperature > 105°C). As a result, motor will stop automatically. The driver for respective channel starts operate again when temperature decrease less than 70°C.

**Note:** MDDS60 does not come with polarity protection, please double check the connection before powering up.

## 9. INPUT MODE

When the SmartDriveDuo-60 is powered up, RUN-L LED, ERR LED and RUN-R LED will running once. After that, the input mode will be read from the DIP switch and retained as long as the driver is powered. If you wish to change the input mode, you will need to change the setting on the DIP switch and **press the “RST” reset button**, or power cycle the driver (Turn it off and turn it on again).

SmartDriveDuo-60 supports four different types of input mode (RC, Analog, PWM and Serial). The DIP switch settings for each mode and the function for input pin are summarized on the following page.

DIP Switch	1	2	3	4	5	6	7	8			
RC	<input type="radio"/>	<input type="radio"/>	<b>Channel:</b> <input type="radio"/> : Mixed <input type="radio"/> 1 : Independent Right <input type="radio"/> 1 <input type="radio"/> : Independent Left <input type="radio"/> 1 1 : Independent Both						<input type="radio"/> : RC		
	<input type="radio"/>	1							<input type="radio"/> : Linear		
	<input type="radio"/>	1							<input type="radio"/> : Exponential		
Analog	<input type="radio"/>	1	<b>Baudrate:</b> <input type="radio"/> <input type="radio"/> 1 : 2400 <input type="radio"/> 1 <input type="radio"/> : 4800 <input type="radio"/> 1 1 : 9600						<input type="radio"/> : Locked Anti-Phase		
	<input type="radio"/>	1							<input type="radio"/> : Sign Magnitude		
	<input type="radio"/>	1									
PWM	1	<input type="radio"/>	<b>Address:</b> Start from <input type="radio"/> <input type="radio"/> <input type="radio"/> to <input type="radio"/> <input type="radio"/> <input type="radio"/>						<b>Battery Monitor:</b>		
		<input type="radio"/>							<input type="radio"/> : LiPo		
		<input type="radio"/>							<input type="radio"/> : NiMH		
Serial Simplified	1	1	<input type="radio"/>	<b>Baudrate:</b> <input type="radio"/> <input type="radio"/> 1 : 19200 <input type="radio"/> <input type="radio"/> 1 : 38400 <input type="radio"/> 1 <input type="radio"/> : 57600 <input type="radio"/> 1 1 : 115200						<input type="radio"/> : SLA	
		<input type="radio"/>	<input type="radio"/> : Off								
		<input type="radio"/>									
Serial Packetized	1	1	<b>Address:</b> Start from <input type="radio"/> <input type="radio"/> <input type="radio"/> to <input type="radio"/> <input type="radio"/> <input type="radio"/>								
		<input type="radio"/>									



## 9.1 RC INPUT MODE

In RC input mode, the speed and direction of the motor is controlled by the signal from the standard hobby radio control transmitter and receiver, or a microcontroller generating the similar signal.

**NOTE:** The RC transmitter must be ON before power up the SmartDriveDuo-60.

RC Input mode is selected by setting the **SW1 & SW2 to 0 (Down)**. SW3 – SW6 can be configured depending on the requirement of the user.

Input Mode	SW1:SW2 00	RC Input Mode
Single/Mix Mode	SW3:SW4 00	<b>Mixed</b> – The motor speed is controlled by channel RC1 and direction is controlled by channel RC2. Recommended this mode if controlled using RC transmitter/receiver.
	01	<b>Independent Right</b> – Only motor Right will active, motor Left will inactive. Motor Right is controlled by channel RC2.
	10	<b>Independent Left</b> – Only motor Left will active, motor Right will inactive. Motor Right is controlled by channel RC1.
	11	<b>Independent Both</b> - Both motor is active and can be controlled individually through channel RC1 and RC2. Recommended this mode if controlled using Microcontroller.
Exponential Mode	SW5 0	<b>Off</b> – The speed is linear with the input signal. This is for low to medium speed motor.
	1	<b>On</b> –The response to input is exponential and thus soften the control around the center zero speed point. This is suitable for high speed and very sensitive motor.
MCU Mode	SW6 0	<b>Off</b> – The center point will be calibrated upon power up. Timeout occurs after lost of signal for 100ms and the motor will be stopped for safety purpose.
	1	<b>On</b> – The center point is fixed at 1.5ms and the timeout feature is disabled. Motor will continue to run with previous speed if new signal is not detected. This is useful when a microcontroller is used to control the motor. The microcontroller does not need to send the pulse continuously to the SmartDriveDuo-60. Instead, it only needs to send a single pulse when the speed or direction of the motor needs to be changed.

0 – OFF      1 – ON      X – Don't Care

Figures below show the connection in RC mode.

RC Mode with RC Transmitter/Receiver (Mixed), DIP switch

1 2 3 4 5 6 7 8  
 0 0 0 0 0 0 0 0

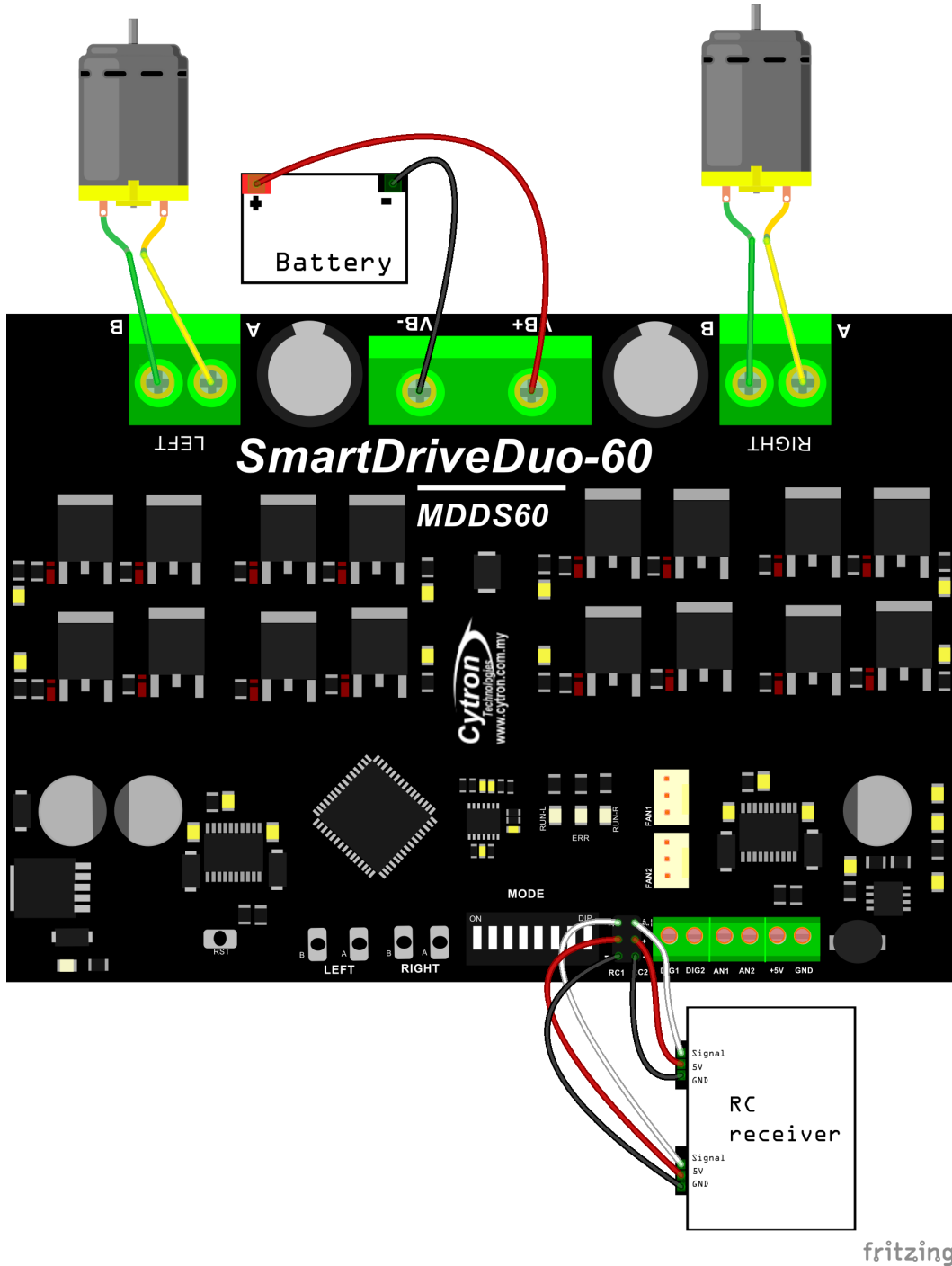

RC Mode with Microcontroller (Independent Both), DIP switch

1 2 3 4 5 6 7 8  
 0 0 1 1 0 1 0 0

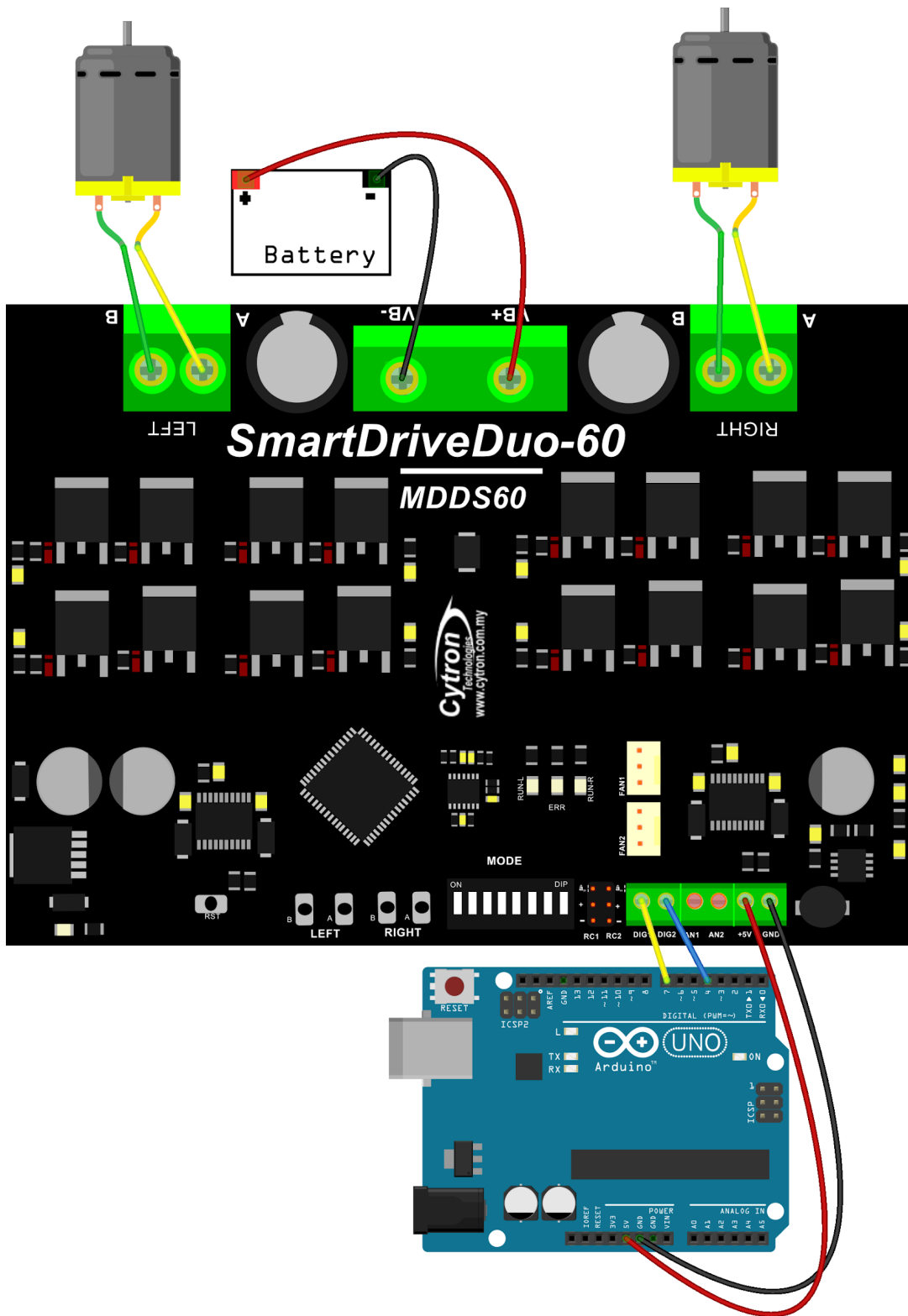

fritzing

## 9.2 ANALOG/PWM INPUT MODE

In Analog/PWM input mode, the speed and direction of the motor is controlled by the analog voltage or PWM signal. The valid input range is 0 – 5V and it's very easy to control by using a potentiometer. For example, the motor can be controlled by a joystick or foot pedal with potentiometer.

**NOTE:** The Analog/PWM signal to stop the motor (2.5V if Sign-Magnitude mode is off, 0V otherwise) must be available when the SmartDriveDuo-60 is turned on. Else, the driver will show Input Error until the correct signal is available.

Analog input mode is selected by setting **SW1 to 0 (Down) and SW2 to 1 (Up)**. PWM input mode is selected by setting **SW1 to 1 (Up) and SW2 to 0 (Down)**. SW3 – SW6 can be configured depending on the requirement of the user.

Input Mode	<b>SW1:SW2</b> 01	<b>Analog Input Mode</b> – The input is analog signal. The filter capacitor is not connected and the input signal is not filtered. SW1 is for Input 1 while SW2 is for Input 2.
	10	<b>PWM Input Mode</b> – The input is PWM signal. The filter capacitor is connected and the input signal is low pass filtered to be an analog signal. SW1 is for Input 1 while SW2 is for Input 2. SW2 must be set to 0 if Sign-Magnitude mode is turned on.
Single/Mix Mode	<b>SW3:SW4</b> 00	<b>Mixed</b> – The motor speed is controlled by channel RC1 and direction is controlled by channel RC2. Recommended this mode if controlled using <a href="#">Breakout board with Joystick soldered</a> .
	01	<b>Independent Right</b> – Only motor Right will active, motor Left will inactive. Motor Right is controlled by channel RC2.
	10	<b>Independent Left</b> – Only motor Left will active, motor Right will inactive. Motor Right is controlled by channel RC1.
	11	<b>Independent Both</b> - Both motor is active and can be controlled individually through channel RC1 and RC2. <b>Recommended this mode if controlled using Microcontroller.</b>
Exponential Mode	<b>SW5</b> 0	<b>Off</b> – The speed is linear with the input signal. This is for low to medium speed motor.
	1	<b>On</b> –The response to input is exponential and thus soften the control around the center zero speed point. This is suitable for high speed and very sensitive motor.
Sign-Magnitude Mode	<b>SW6</b> 0	<b>Locked Anti-Phase</b> – Motor stops when the input signal is 2.5V. Motor moves in one direction when the input is < 2.5V and in another direction when the input is > 2.5V. Recommended this mode if controlled using <a href="#">Breakout board with Joystick soldered</a> .
	1	<b>Signed Magnitude</b> – AN1 and AN2 controls the speed of the motor. Motor stops when the input is 0V and run at full speed

		when the input is 5V. DIG1 and DIG2 is digital inputs and it controls the direction of the motor respectively.
--	--	--

0 - OFF      1 - ON      X - Don't Care

Figures below show the connection in analog/PWM input mode.

Analog input mode with Joystick board (Mixed), DIP switch

**DIP Switch Setting**

1 2 3 4 5 6 7 8

0 1 0 0 0 0 0 0

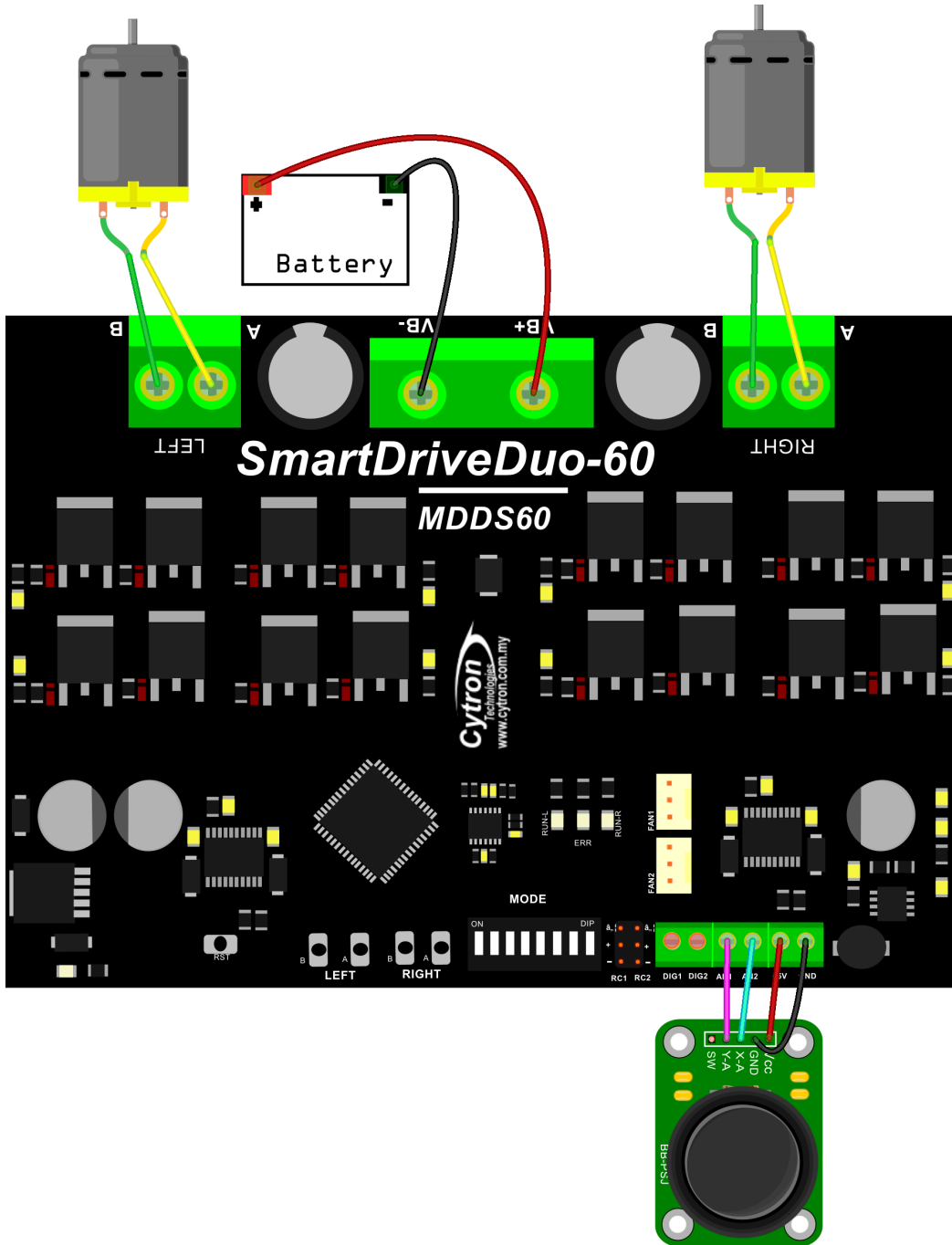

fritzing

PWM input mode with microcontroller (Independent Both), DIP switch

**DIP Switch Setting**

1 2 3 4 5 6 7 8  
 1 0 1 1 0 1 0 0

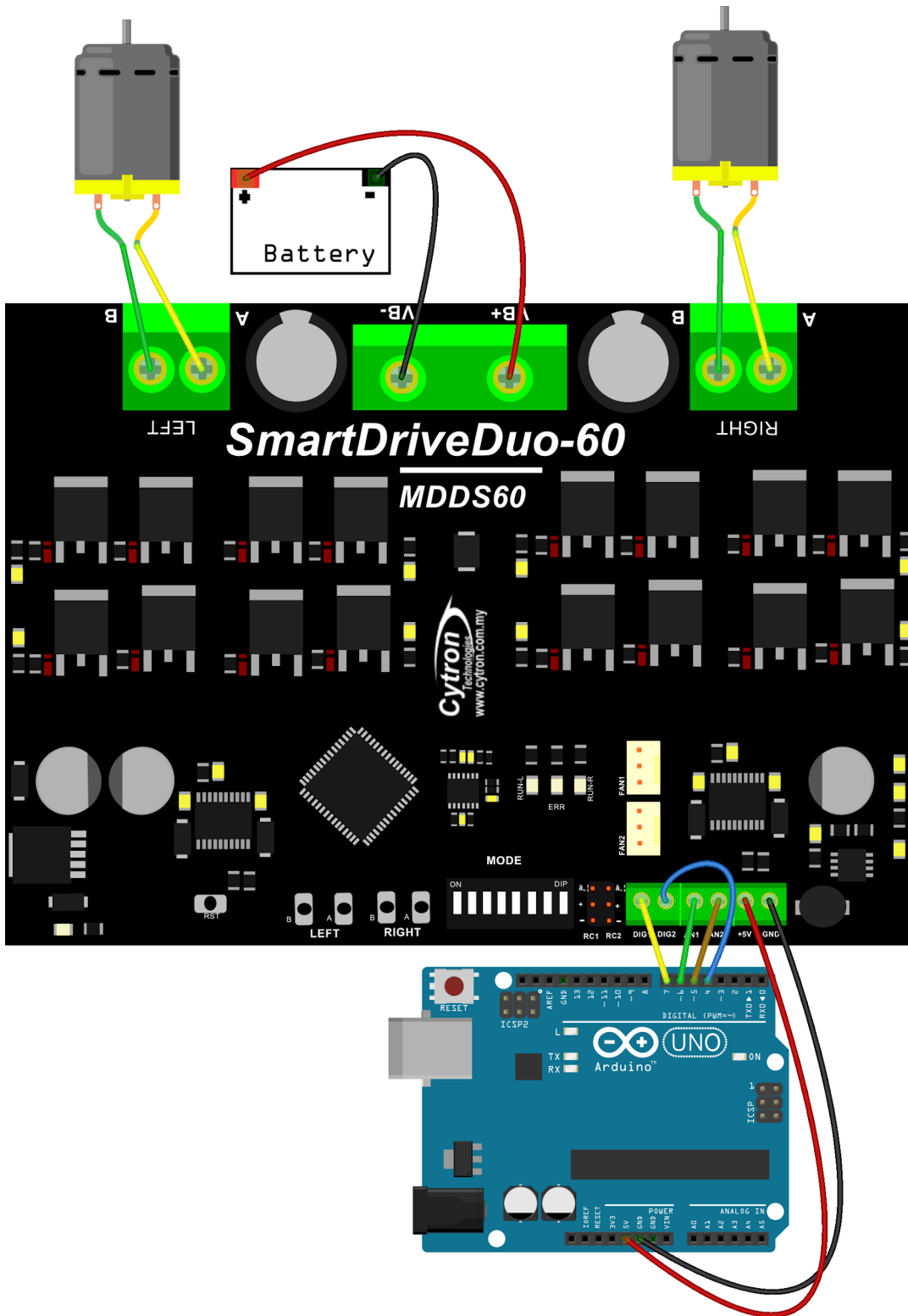

fritzing

### 9.3 SERIAL SIMPLIFIED MODE

In Simplified Serial mode, SmartDriveDuo-60 is controlled by using the UART interface. DIG1 pin is the UART Rx. DIG2, AN1 and AN2 pins are not used in this mode.

A single byte of data is all you need to control the speed and direction for each motor. First MSB bit is to select which motor to control, and the rest bits is to control.

Bit	7 (MSB)	6	5	4	3	2	1	0 (LSB)
Function	Channel	Direction	Speed					

Bit 7 (Channel): 0 - motor LEFT, 1 - motor RIGHT.

Bit 6 - 0: Control motor direction and speed.

Example: Value in Decimal

- 0 or 64 - motor LEFT stop.
- 63 - motor LEFT full forward.
- 127 - motor LEFT full reverse.
- 128 or 192 - motor RIGHT stop.
- 191 - motor RIGHT full forward.
- 255 - motor RIGHT full reverse.

Simplified Serial mode is selected by setting **SW1, SW2 to 1 (Up) and SW3 to 0 (Down)**. SW4 – SW6 are used to select the UART baud rate.

Input Mode	SW1 - SW3 110	Simplified Serial Mode
UART Baud Rate	<b>SW4 - SW6</b>	<b>Baud Rate</b>
	000	1200
	001	2400
	010	4800
	011	9600
	100	19200
	101	38400
	110	57600
111	115200	

0 - OFF      1 - ON      X - Don't Care

Figure below shows the connection to multiple SmartDriveDuo-60 in Simplified Serial Mode.

Simplified Serial mode with microcontroller (9600bps), DIP switch

**DIP Switch Setting**

1 2 3 4 5 6 7 8  
 1 1 0 0 1 1 0 0

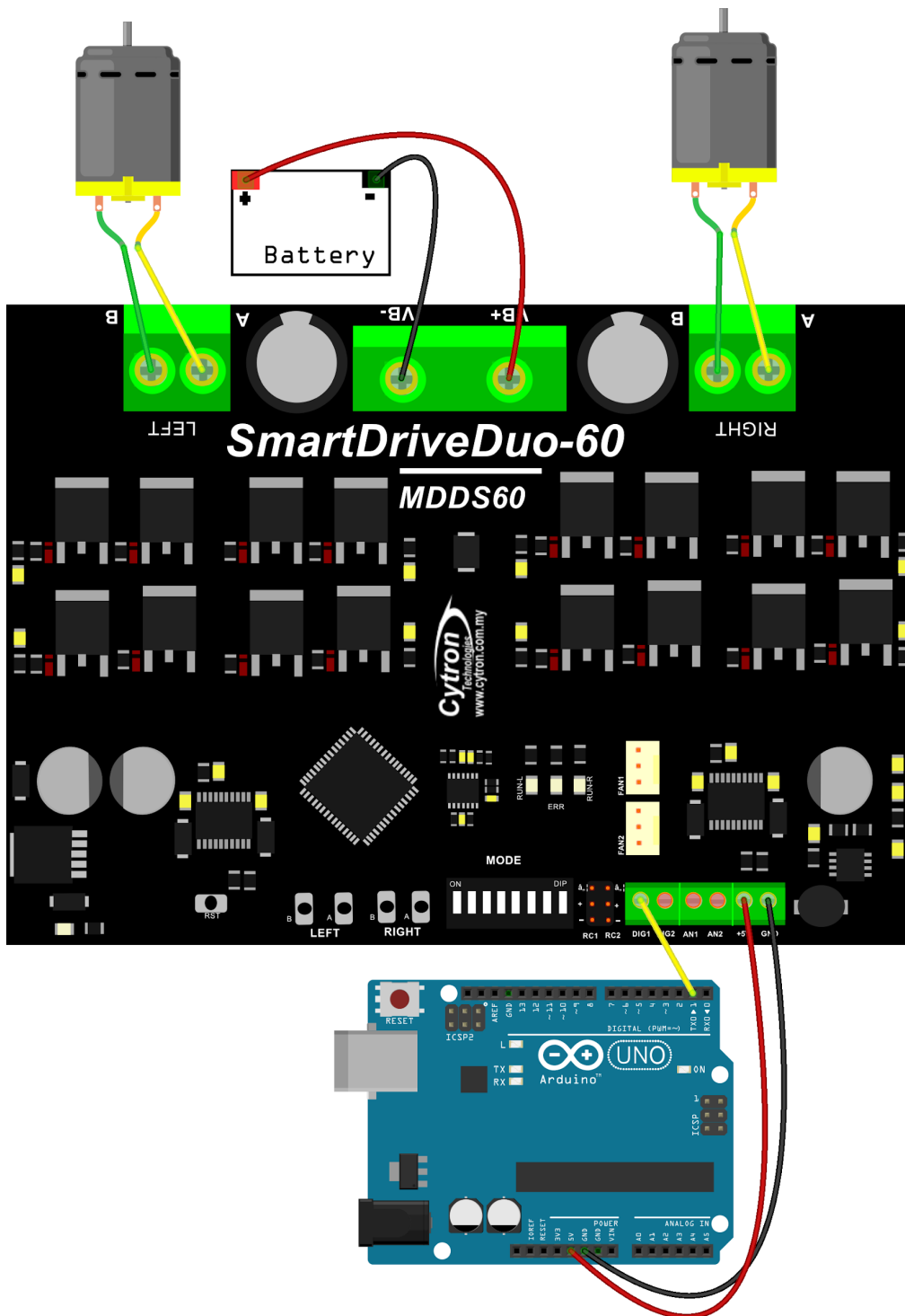

fritzing



## 9.4 SERIAL PACKETIZED MODE

In Packetized Serial mode, SmartDriveDuo-60 is controlled by using the UART interface. DIG1 pin is the UART Rx pin. DIG2, AN1 and AN2 pins are not used in this mode. To control the motor, data sent to the driver must be in 4 bytes packet format which includes a header, address, command and checksum. Up to 8 units of SmartDriveDuo-60 can be connected together to a single microcontroller UART Tx pin.

Besides that, the SmartDriveDuo-60 also incorporates an Auto-Baud feature in Packetized Serial mode. When the driver is first powered up, the host microcontroller must send a header byte (Decimal 85 or hex 55) once to the driver. The driver will then calculate the baud rate automatically based on this byte. After that, SmartDriveDuo-60 is ready to read full packet (4 bytes) and the baud rate cannot be changed without power recycle (power off and on) or reset button.

**NOTE:**

1. When the driver is powered up and waiting for the header byte, the error LED will blink and indicate that there is input error.
2. SmartDriveDuo-60 may take up to 500ms to start up after power is applied. Sending the header byte for auto baud during this time period may cause undesirable results. Please allow one-second delay between applying power and sending the header byte.

Packetized Serial mode is selected by setting **SW1, SW2 and SW3** to **1 (Up)**. SW4 – SW6 are used to select the address.

Input Mode	<b>SW1 - SW3</b> 111	<b>Packetized Serial Mode</b>
UART Address	<b>SW4 - SW6</b> 000 - 111	<b>0 - 7</b>

0 - OFF      1 - ON      X - Don't Care

A packet consists of 4 bytes and the format is shown in the following table.

Byte	Name	Value (Decimal)	Description
1	Header	85	To indicate the start of packet.
2	Channel & Address	Channel: Bit 3 Address: Bit 2 - 0	Used to identify the driver when multiple units are connected together. The address bits (bit 2 - 0) must match the address configured with the DIP switch. Bit 3 represent which motor to be controlled, 0 for motor LEFT and 1 for motor RIGHT.
3	Command	0 – 255	Value 127 stops the motor, 0 is full reverse and 255 is full forward.
4	Checksum	0 – 255	The value for checksum must be the result of Header + Address + Command

Figure below shows the connection to multiple drivers in Packetized Serial Mode.

Packetized Serial mode with microcontroller (Address = 0), DIP switch

**DIP Switch Setting**  
 1 2 3 4 5 6 7 8  
 1 1 1 0 0 0 0 0

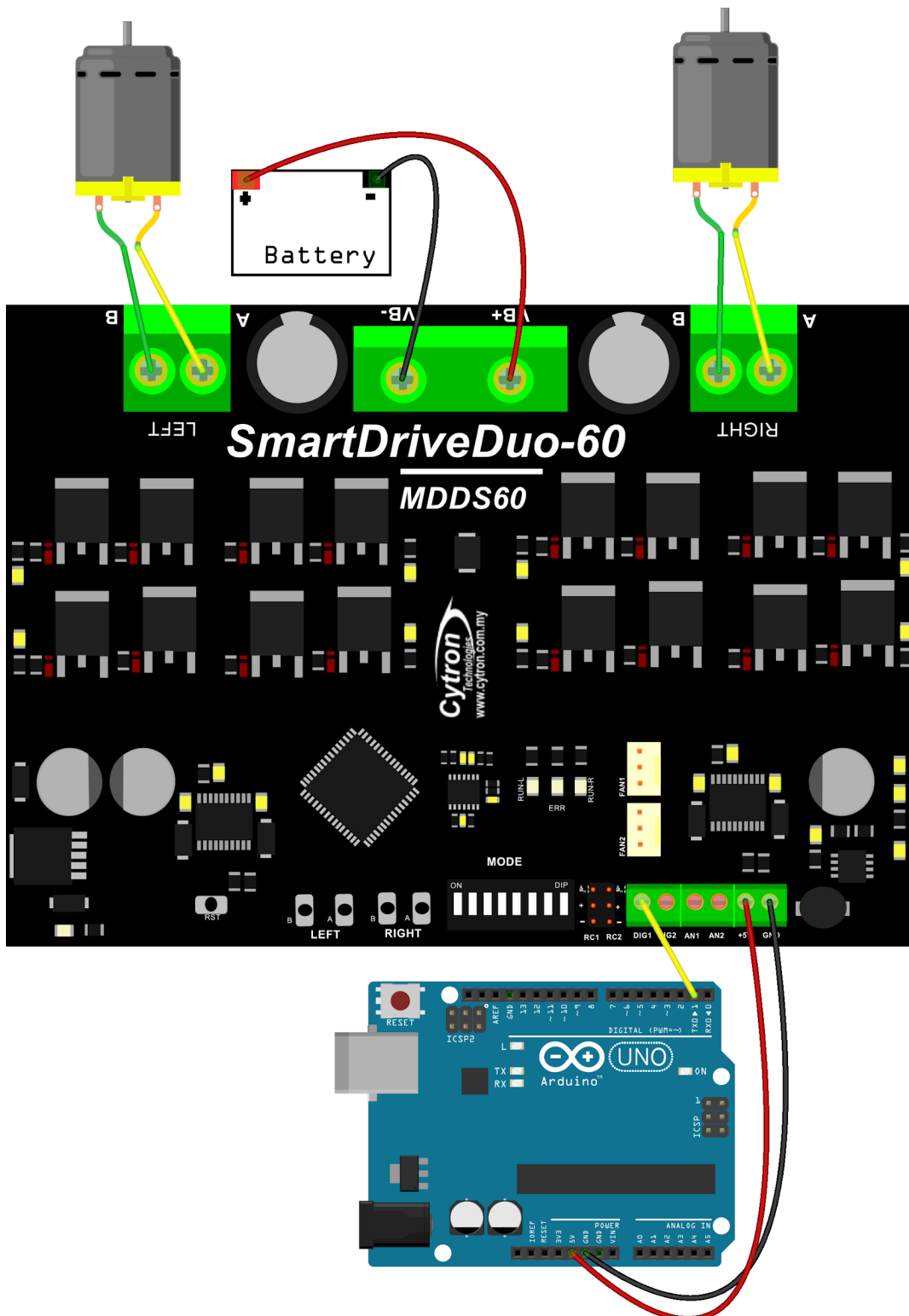

fritzing

## 10. WARRANTY

- Product warranty is valid for 12 months.
- Warranty only applies to manufacturing defect.
- Damaged caused by misuse is not covered under warranty
- Warranty does not cover freight cost for both ways.

*Prepared by:*

***Cytron Technologies Sdn. Bhd.***

No. 16, Jalan Industri Ringan Permatang Tinggi 2,  
Kawasan Industri Ringan Permatang Tinggi,  
14100 Simpang Ampat,  
Penang, Malaysia.

*Tel:* +604 - 504 1878

*Fax:* +604 - 504 0138

*URL:* [www.cytron.com.my](http://www.cytron.com.my)

*Email:* [support@cytron.com.my](mailto:support@cytron.com.my)  
[sales@cytron.com.my](mailto:sales@cytron.com.my)