

[www.codlai.com/en](http://www.codlai.com/en)

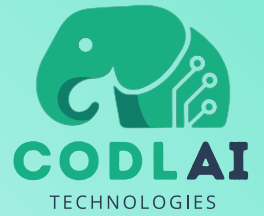

# CARBOT INSTALLATION GUIDE

"ROBOTIC CODING FOR EVERYONE"

**CarBot Installation Guide**

2025 (v2.0)

CODLAI

# Contents

<b>i. CarBot Assembly Instructions</b>	ii
<b>ii. What Do We Offer?</b>	iii
<b>Warning</b>	2
<b>1. Introduction</b>	2
1.1 Regulatory Information	2
1.2 Safety Instructions	2
1.3 Guidance Information	3
<b>2. Basic Information</b>	4
2.1 Overview	4
2.2 Dimensions	4
<b>3. Diagram and Material List</b>	5
3.1 CarBot Diagram	5
3.2 Material List	5
<b>4. CarBot Assembly Instructions</b>	6
4.1 Mechanical Assembly	6
4.2 Electronic Assembly	11
4.3 Calibration	13
<b>Closing</b>	15

[www.codlai.com/en](http://www.codlai.com/en)

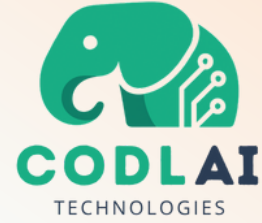

# Who Are We?

## *CODLAI TECHNOLOGIES INC.*

CODLAI Technology Inc. was founded during the pandemic, when the challenges and shortcomings of distance learning became apparent. During this period, it was observed that the existing infrastructure, particularly in robotics coding and similar practical courses, was inadequate, leading to significant decreases in productivity. To address these issues, in 2021, one of our founders and a graduate student, Samed Kaya, completed his thesis titled "Internet-Oriented Sensor Board Design and Production for Intermediate and Advanced Robotics Coding Education." This work laid the foundation for the CODROB brand and our first products, the IoTBot and sensor modules.

The resulting products have attracted attention with their innovative features as well as eliminating the deficiencies in the market. In 2022, with the partnership of Kule Mold Machinery and Industry INC. located in Gebze/Kocaeli, CODROB has gained wider opportunities and developed new generation programmable robots, advanced program called "CODROB Editor" and web platform.

The CODROB Project, awarded the "Seal of Excellence" in the first call of the 2025 TÜBİTAK 1812 (BIGG) Program, began its R&D and commercial activities under the name "**CODLAI TECHNOLOGY INC.**" The company operates in the Teknopark Istanbul area.

CODLAI currently offers a wide range of products, including three different programmable IoT-based motherboards, more than 20 sensor modules, programmable cars, robotic arms, and drones. Furthermore, it aims to meet all needs in the field with its next-generation AI-powered products, coding editor, and training curriculum. Curricula and sample projects appropriate to the learning level have been created for all devices produced.

## **Our Future Vision**

As CODLAI, we aim to focus on innovative topics such as new programmable motherboards, developable robots for robotics competitions, and robotic coding via virtual reality in the future. Our aim is to provide pioneering and innovative solutions in educational technologies and to ensure that students and educators have the best experience.

## **Our Mission**

As CODLAI Technologies Inc., our mission is to provide innovative, accessible and effective solutions to students and educators by using technology in education in the most effective way. We aim to raise the technology leaders of the future by increasing the quality in robotic coding and applied courses. In this direction, with our constantly developing product range and educational materials, we aim to provide practical and advanced technology-based educational tools that are suitable for the needs of learners at all levels. Increasing efficiency in education, integrating technological innovations into the world of education and developing products that can compete on a global scale are among our basic principles.

CODLAI@2025 All Rights Reserved.

[www.codlai.com/en](http://www.codlai.com/en)

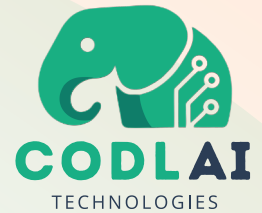

# What Do We Offer?

## STEM TRAINING KITS

*You can learn robotics and electronics from scratch to advanced level with training sets consisting of CODLAI Products!*

## PROGRAMMABLE ROBOTIC KITS

*You can reinforce the foundations established with training kits with robotic kits, and learn what, when, where and how you can use it in daily life!*

## CODLAI EDITOR

You can perform either block-based or text-based programming and simulation with the dual-language supported 'CODLAI Editor' program that you can use on all platforms. Moreover, a web editor that does not require installation is waiting for you! For more: [www.editor.codlai.com](http://www.editor.codlai.com)

## CURRENT CURRICULUM

CODLAI products are supported by course programs and sample applications prepared by leading instructors in the sector. Get a 1-0 head start on your training with its current and even future-visioned curriculum.

## RELIABLE CONTENT

Our sample applications and programs on our CODLAI site have been prepared by expert trainers and checked by our engineer team. We take a firm stance against misinformation and misinformation!

## ALWAYS FULL SUPPORT

CODLAI products are always with you, not just until the first sale. We are waiting for you at [www.codlai.com](http://www.codlai.com), where you can find all kinds of support and updated content about the products! You can also always get a response as quickly as possible with our Whatsapp live support line.

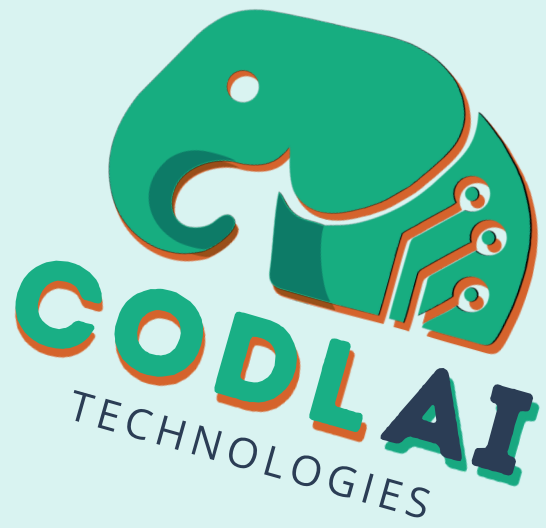

## CarBot Installation Guide

Basic Information  
Parts List  
Basic Information  
CarBot Assembly Instructions

# WARNING

The information contained in this manual, including products and software, may not be reproduced, transmitted, copied, stored, or translated into any language. SUPPLIERS (MANUFACTURERS AND RESELLERS) SHALL NOT BE LIABLE FOR ANY ERRORS OR OMISSIONS IN THIS MANUAL OR FOR DAMAGES THAT MAY RESULT FROM USER USAGE. The images and illustrations in this manual are for illustrative purposes only. Actual product appearances may differ based on various terms and conditions. The content of this manual is subject to change without prior notice or confirmation.

## 1. Entrance

### 1.1 Overview of the Regulation

- **CE Compliance**



*This device is appropriate for both residential and commercial environments. The CE Mark indicates compliance with European Union regulations.*

- *Electromagnetic Compatibility (EMC) Directive 2014/30/EU*
- *Low Voltage Directive 2014/35/EU (equivalent to A2:2013)*
- *Radio and Telecommunications Terminal Equipment (R&TTE) Directive 1999/5/EC*

### 1.2 Safety Guidelines



Avoid using this device in proximity to magnetic fields, as this may negatively impact its performance.



If you suspect an issue with the device or any of its components, please consult the technical service team. In the event of a malfunction, the device should be repaired by the technical service. Kindly refrain from attempting repairs on your own.



Avoid applying excessive pressure to the device through striking, dropping, or pushing it. Such actions may result in damage to or destruction of the device and its components.



Avoid exposing the device to direct sunlight. Keep it away from high-temperature environments and refrain from contact with hot surfaces.



Avoid direct exposure of your device to liquids. Refrain from leaving it in rainy or humid conditions, and take measures to prevent such exposure. Do not keep the product's power adapter connected during thunderstorms or heavy rainfall.



Keep the device, its accessories, components, and packaging out of reach of infants and children to mitigate the risk of suffocation and injury.

### 1.3 Guidance Information



**ATTENTION:** This sign and warning message denotes specific regulations that must be adhered to for user safety.



Before utilizing your device for the first time, please read and adhere to this original user manual along with the accompanying safety warnings. Retain this manual for future reference or for subsequent users.



- Before utilizing CarBot, ensure that it is assembled properly.
- Conduct the installation in a spacious, clean, and level area.
- Keep children and pets away from components during installation.

# 1.2. Fundamental Information

## 2.1 Overview



Picture 1 - CarBot

CarBot is a versatile mechanical instrument developed by the Codlai R&D team for application in your robotics projects. CarBot offers a broad spectrum of functionalities;

- It can be outfitted with MiniBot and operate autonomously.
- Equipped with MiniBot, IoTBot can be operated through Wi-Fi using a computer, phone, or tablet.
- It can be directly controlled with the IoTBot utilizing an appropriate cable.
- Due to its expandable platform, it can accommodate a range of sensors.
- The entire product is manufactured using 3D printing technology. This allows you to produce the components on your own 3D printer and even innovate by adding new features. The installation of CarBot is notably straightforward and user-friendly.

In addition to these features, the Codlai editor offers specialized block options for CarBot.

## 2.2 Dimensions

Package Dimensions	: 30 cm x 25 cm x 10 cm (Shipped disassembled)
Installed Dimensions	: 24.5 cm x 19 cm x 9 cm
Product Weight	: 497 gr

# 3. Diagram and Inventory of Materials

## 3.1 CarBot Schematic

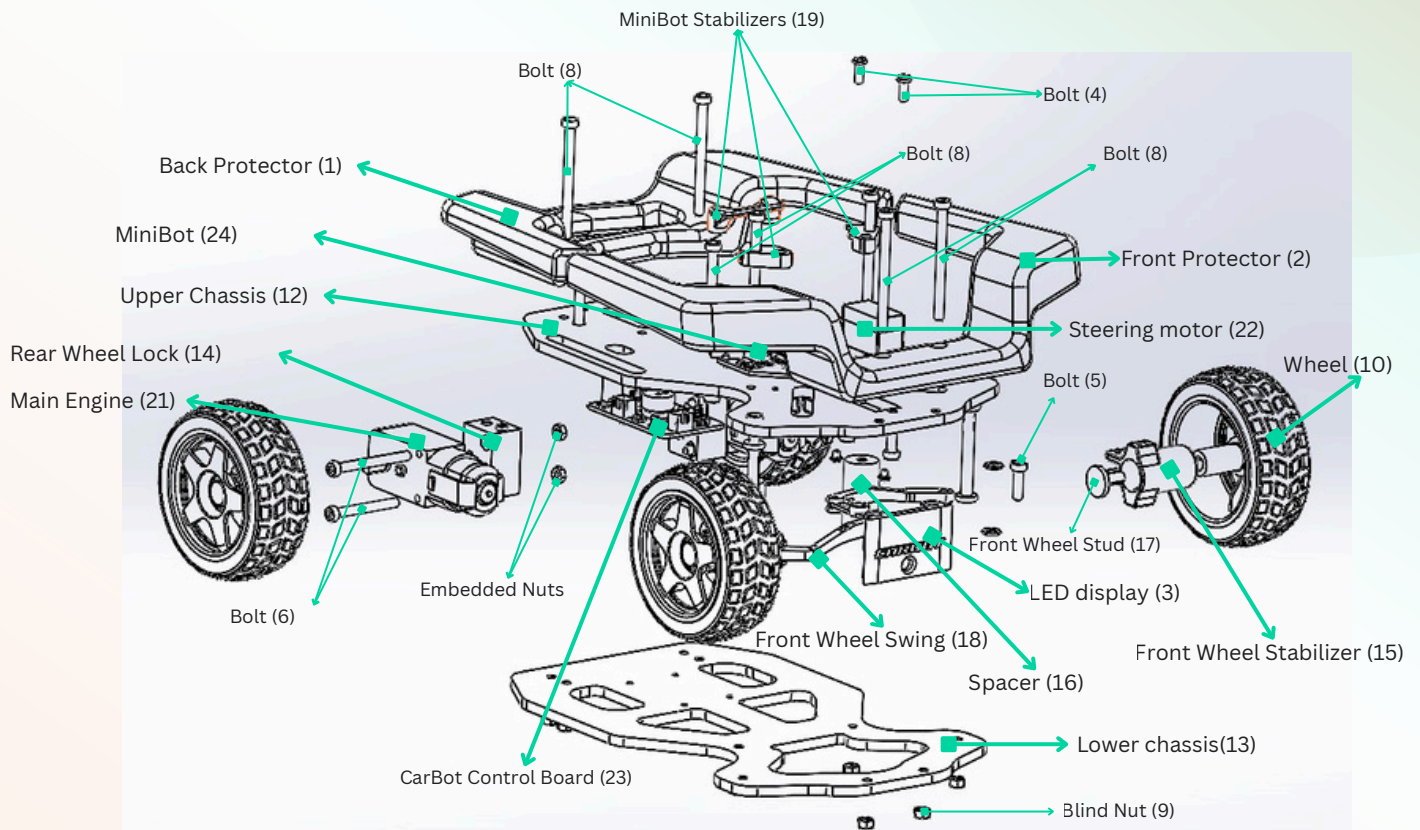

Picture 2 - CarBot Schematic

## 3.2 Inventory of Materials

PICES NO.	PIECES	QN.	PICES NO.	PIECES	QN.
1	Back Protector	1	13	Lower Chassis	1
2	Front Protector	1	14	Rear Wheel Lock	2
3	Plate and LED	1	15	Front Wheel Stabilizer	2
4	M3 x 8 mm Bolt	4	16	Spacer	2
5	M3 x 12 mm Bolt	2	17	Front Wheel Stud	2
6	M3 x 30 mm Bolt	4	18	Front Wheel Swing	2
7	M3 x 35 mm Bolt	2	19	MiniBot Stabilizers	3
8	M3 x 45 mm Bolt	6	20	Servo Motor Tip	1
9	M3 Blind Nut	8	21	Main Motors	2
10	Wheel	4	22	Steering Motor	1
11	Com. Cable	1	23	CarBot Control Board	1
12	Upper Chassis	1	24	MiniBot	1

# 4. CarBot Assembly Guidelines

## 4.1 Mechanical Assembly

The assembly components are outlined in the preceding section. The parts required for the instructions provided below are indicated in parentheses, and each step is accompanied by images to aid in the assembly process. It is important to establish an appropriate assembly environment and to adhere to the steps sequentially.

### ***Assembly Step - 1: Assembly of the Front Wheel***

Install the front wheel stud components (17) onto the front wheel stabilizer components (15), then attach the wheels (10).



Picture 3 - Step 1 of Assembly

### ***Assembly Step - 2: Rear Wheel Installation***

Attach the primary motors (21) to the rear wheel mounting components (14) and fasten them with bolts (6). Connect the wheels (21) to the primary motor supports.

NOTE: Ensure that the DC motor is properly secured to the rear wheel stabilizer.

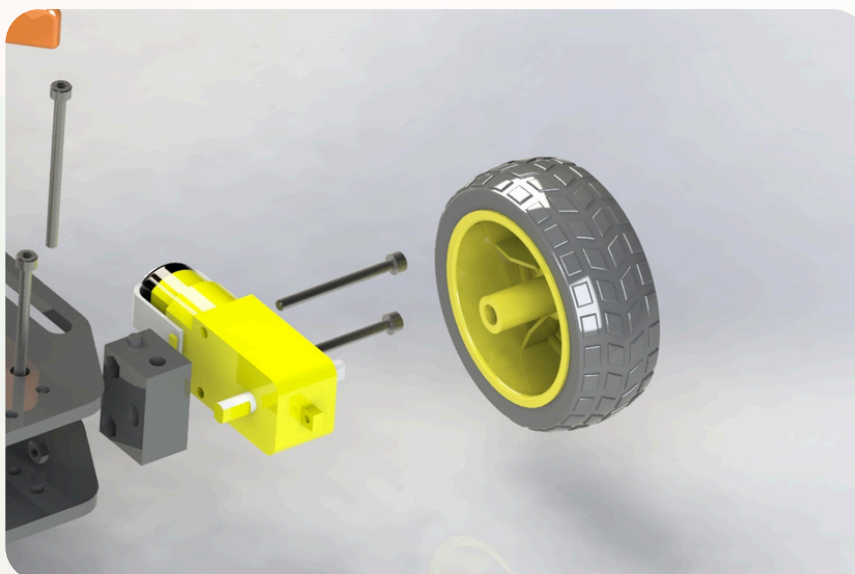

Picture 4 - Step 2 of Assembly

### **Assembly Step - 3: Assembly of the Steering System**

Attach the steering motor (22) to the upper chassis (12) and connect the servo motor end (20) to the steering motor. Affix the front wheel wishbones (2) to the servo motor end with the inclination directed downwards, securing them to the wishbones using the screws included in the steering motor package (utilize the last screw hole of the propellers). The servo motor end fixing screw will be attached to the motor following calibration. Secure the front wheel fixing components prepared earlier (assembly step - 1) to the free ends of the wishbones using bolts (5). Connect the chassis and front wheel block from the upper section of the chassis with bolts (7).

- Utilize the screws with washer heads from the steering motor package on the perforated section (9) of the servo motor end, and the flat screw on the central part of the servo motor end.
- Reversing the swing direction will limit movement. Install as illustrated in the image. (Picture 5)

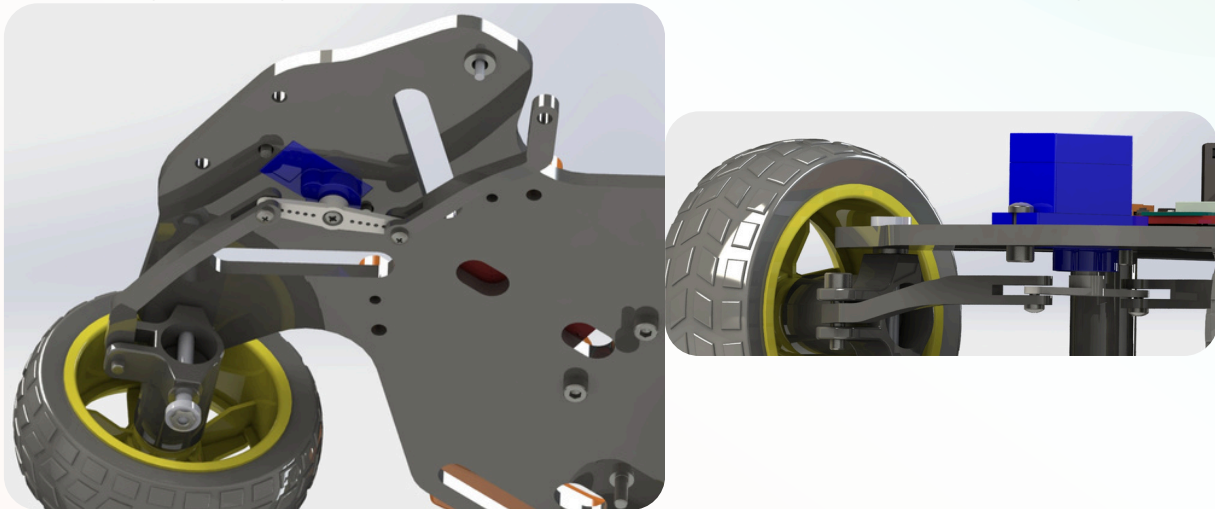

**Picture 5 - Step 3 of Assembly**

### **Assembly Step - 4: Assembly of the CarBot Control Card**

Attach the CarBot control card (23) to the lower chassis (13) using the bolt (4).

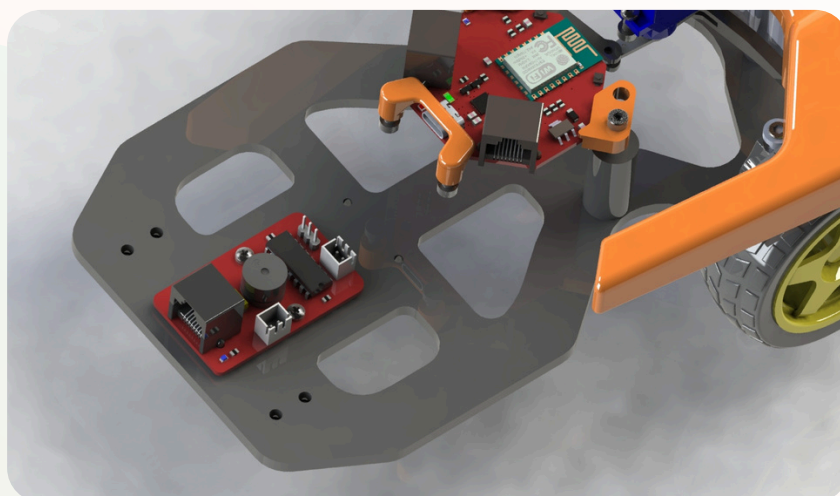

**Picture 6 - Step 4 of Assembly**

### ***Assembly Step - 5: Assembly of Lower and Upper Chassis***

After positioning the two smaller components of the MiniBot fixing parts (19) in their designated spots on the upper chassis, insert the bolts (8) and secure the spacer components (16) to these bolts. Then, connect the lower chassis (13) and the upper chassis (14) using the bolts that were previously affixed to the front wheel block, and tighten the ends of the bolts with the blind nut (9).

- Leaving the nuts loose and securing them after assembly will facilitate the assembly process.

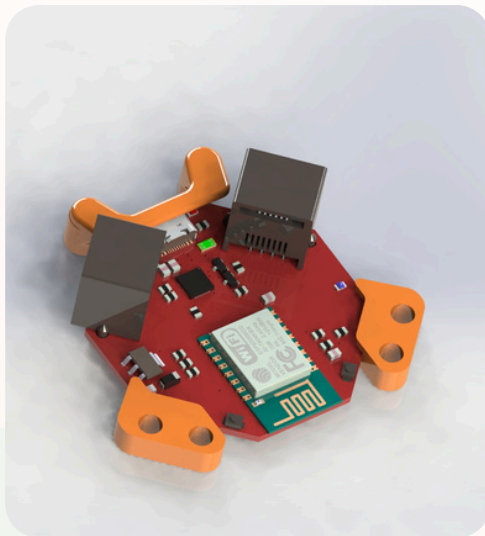
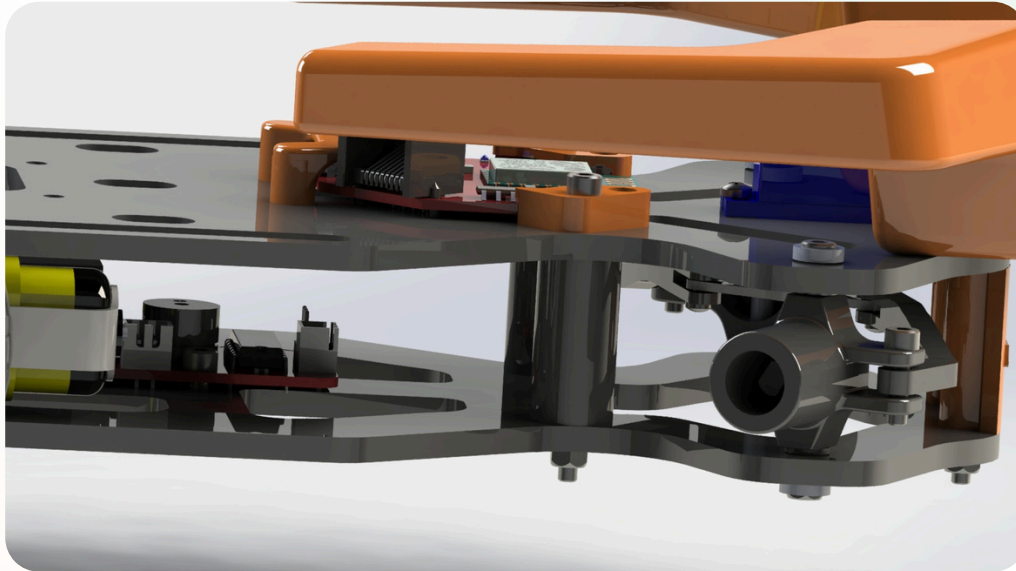

Picture 7 - Step 5 of Assembly

### Assembly Step - 6: Connecting the Steering Motor Electrically

Ensure the servo motor socket is properly connected to the CarBot control board. (Picture 8)

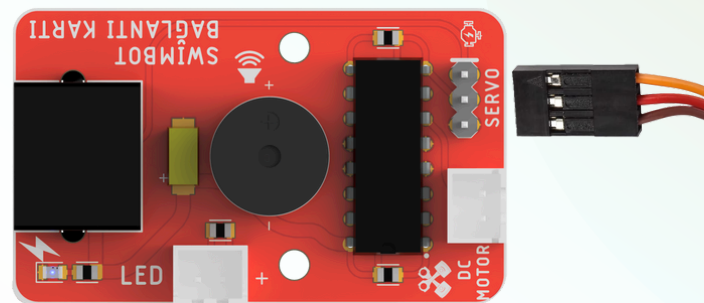

Be mindful of the cable colors during installation!

Picture 8 - Step 6 of Assembly

### Installation Step - 7: Mounting the Plate and Connecting the LED

Fasten the plate and LED component (3) along with the front protective part (2) to the chassis using the bolt (8) and secure the bolt end with the blind nut (9). Properly connect the LED socket to the CarBot control board. (Picture 9)

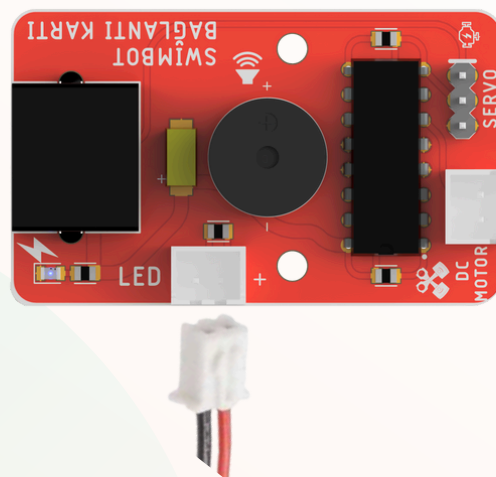

Be mindful of the cable colors during installation!

Picture 9 - Step 7 of Assembly

### **Assembly Step - 8: Assembly of the Main Engine and Electronic Connections**

Connect the DC motor socket to the CarBot control board properly. Position the rear wheel fasteners between the chassis. Fasten the rear wheel fasteners with the rear protective part (1) to the chassis using bolts (8) and tighten the ends of the bolts with the blind nut (9).

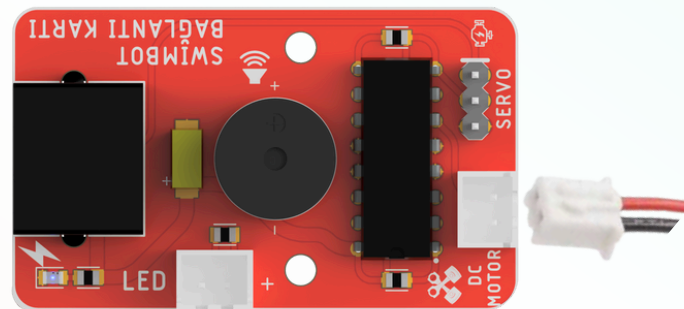

Picture 10 - Step 8 of Assembly

### **Assembly Step - 9: Assembly of the MiniBot Control Card**

9. Connect the final section of the MiniBot stabilizer (19) and fasten it using the bolt (4) from the underside of the vehicle.



Picture 11 - Step 9 of Assembly

## 4.2 Electronic Construction

To operate CarBot and maneuver it according to our preferences, we will utilize the circuit boards of MiniBot and CarBot. CarBot will link to our motors, while MiniBot will supply the necessary power. We will now proceed to connect the motors and LEDs.

- The 7 cm long cables will be correctly positioned on the connection pins of our motors and soldered with solder paste. Care must be taken during soldering to protect the plastic components and to ensure the cables are oriented properly.

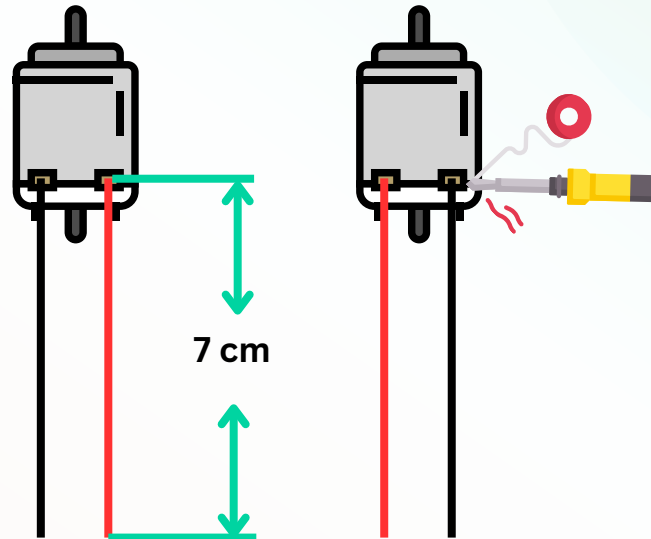

Picture 12 - Electronic Assembly Phase 1

- To achieve synchronous operation of the motors, we connect them in series and create a joint using a third cable. This joint point is then soldered and covered with shrink tubing. We ensure that our third cable measures 4 cm.

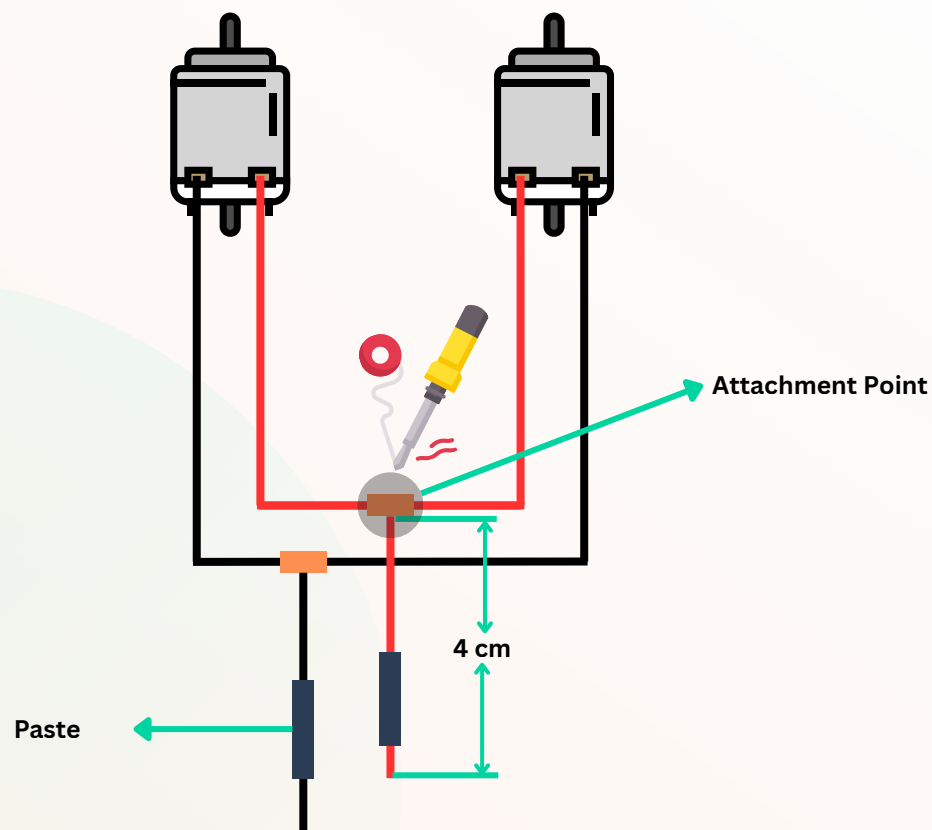

Picture 13 - Electronic Assembly Phase 2

- We shorten the legs of the LEDs, solder 18 cm wires to the ends, and cover them with shrink tubing. This will serve as the headlight for the LED CarBot.

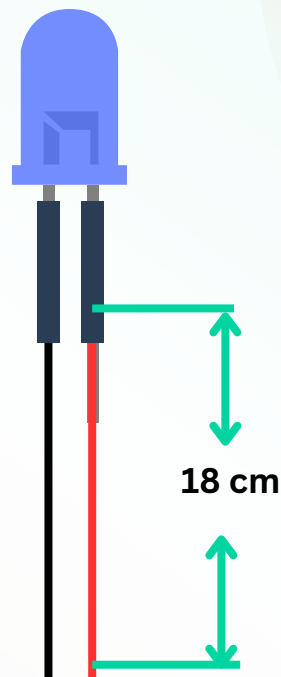

Picture 14 - Electronic Assembly Phase 3

- Sockets will be inserted into the cable ends of the LEDs and Motors. (The box will be dispatched with the socket inserted.) All sockets will be verified and connected to the CarBot card. It is essential to ensure that the sockets are inserted correctly and placed in the appropriate sections on the card.

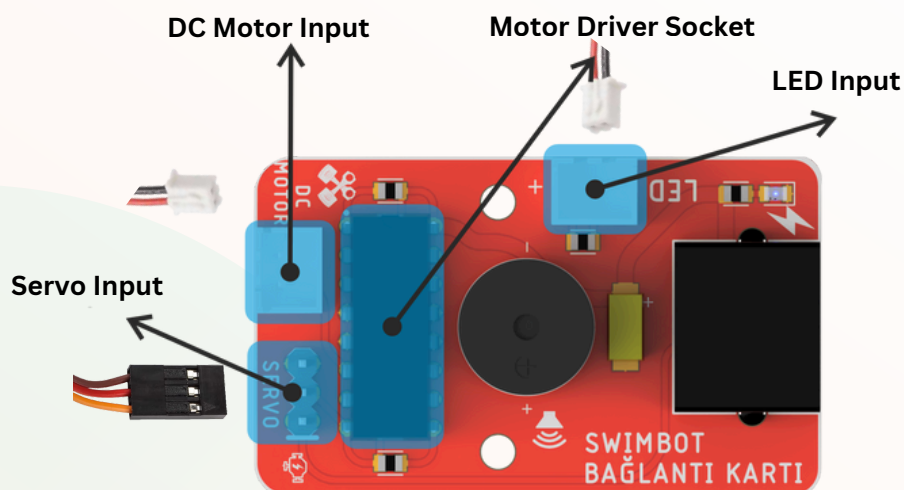

Picture 15 - Electronic Assembly Phase 4

### 4.3 Calibration

In order for CarBot to work properly, its motors need to be calibrated. We will calibrate the motors with the Codlai Editor. We load the code below into the Codlai editor (MiniBot).

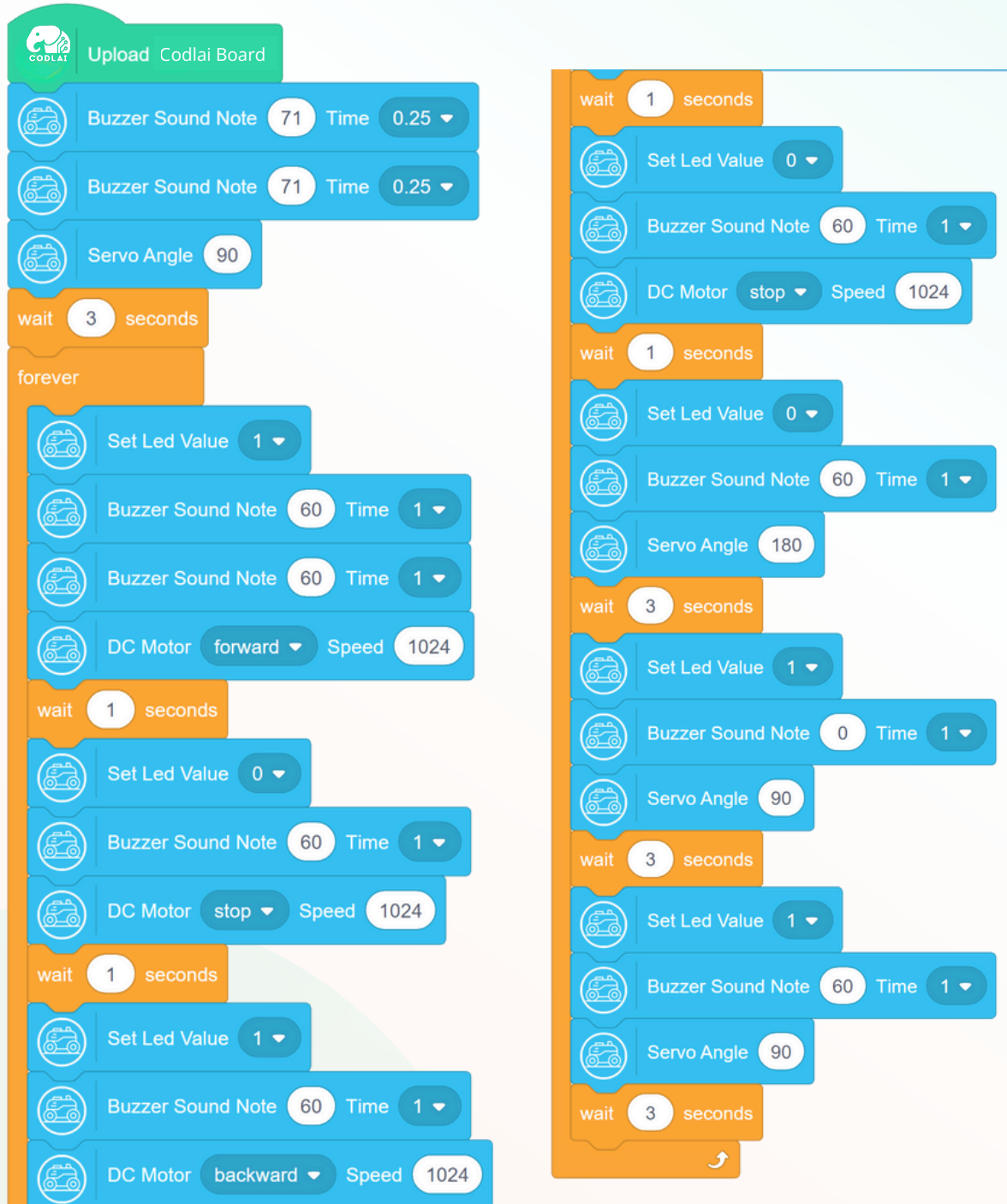

Picture 15 - Codlai Editor CarBot Calibration Blocks

### 4.3.1 Calibration Instructions

- After uploading the code, turn MiniBot off and on.
- Wait for the steering motor to reach a 90° angle. (Picture 16)
- When the motor is fixed, connect the steering motor and servo motor end with a screw so that the wheels are straight.

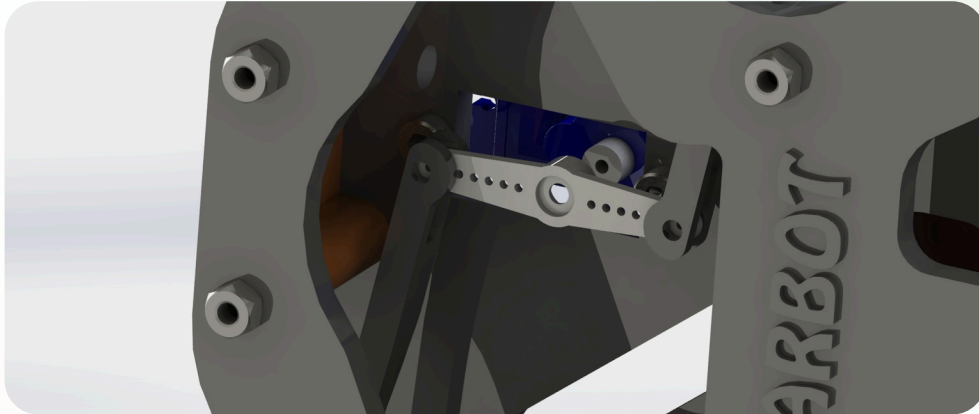

Picture 16 - Motor & Servo Motor End Calibration Angle 90°

After calibration, insert the screw into the propeller and tighten it. (Picture 17)

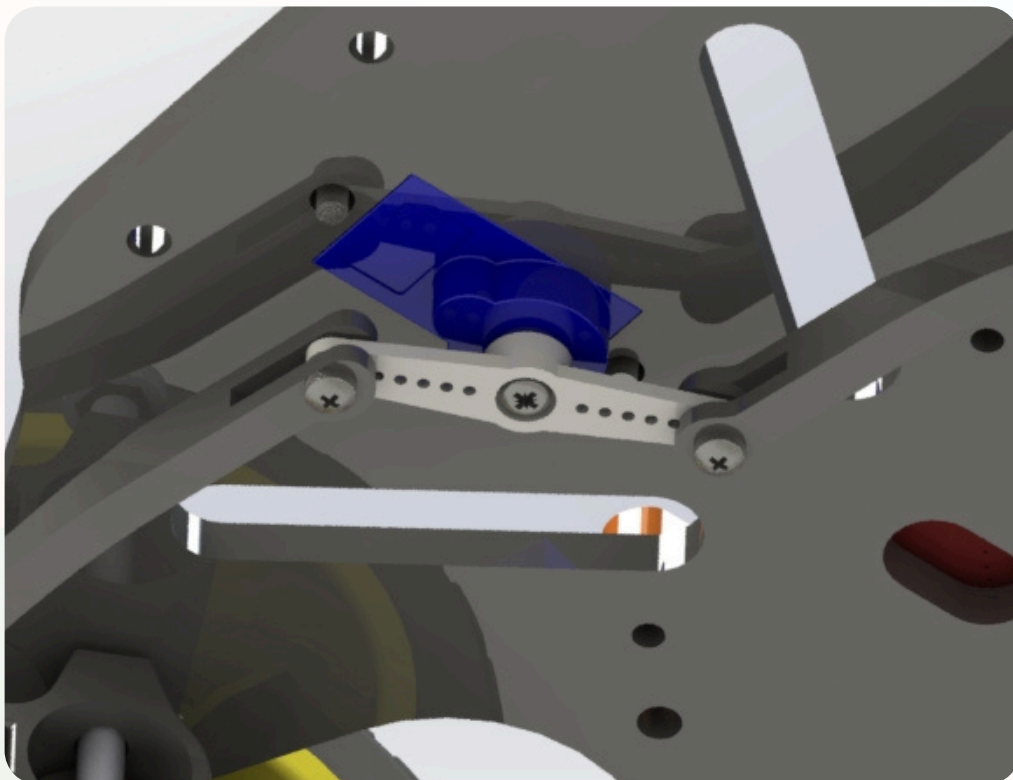

Picture 17 - Motor & Servo Motor Calibration

# CARBOT INSTALLATION GUIDE

"ROBOTIC CODING FOR EVERYONE"

## *CODLAI TECHNOLOGIES INC.*

In this period when technology is advancing Decently, robotics and coding skills are among the most valuable competencies of the future. CODLAI Technologies A.S. as such, we invite you to step into this exciting world.

### **Encode the Future with CODLAI**

Our mission is to provide innovative, accessible and effective solutions to students and educators by using technology in education in the most effective way.

### **Be the Technology Leaders of the Future**

We aim to educate the technology leaders of the future by increasing the quality in robotic coding and applied courses. With our constantly developing product range and educational materials, we offer practical and advanced technology-based educational tools that are suitable for the needs of students at all levels.

CODLAI Technologies INC.

"Innovative Solutions in Education, Strong Steps to the Future"

[www.codlai.com/en](http://www.codlai.com/en)



Pendik / ISTANBUL



[info@codlai.com](mailto:info@codlai.com)



[+90 \(536\) 593 65 84](tel:+90(536)5936584)



**2025** (v2.0)