

BRAVO 7

A Tough, 7-Function Manipulator for Inspection Class Vehicles

The Bravo 7 is a 7-Function manipulator that opens up new compact inspection and intervention opportunities for service providers, researchers, and other operators.

- **DEXTEROUS**
7-Function (or custom fit)
Highly Modular & Configurable
- **RUGGED**
450m Depth Rating (600m in future)
10kg Full Reach Lift
- **SMART**
In-Built Kinematics
Master Arm Controlled

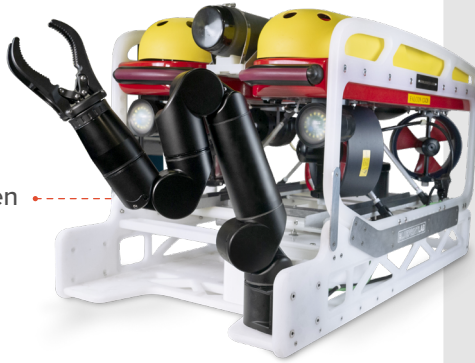

ROV & UGV Proven

NEW MK2 FEATURES

- Slip-rings in all inlines
- Increased 450m depth rating (600m rated in the future)
- High strength linear (approx. up to 10kN)
- Higher joint speed
- Increased reliability & easier maintenance

FEATURES

- Ready-built and designed for industry leading inspection-class vehicles
- All-Electric, Zero Oil
- End effectors: grabbers, probe handlers, cutters (or BYO)
- Advanced software interface with 3D visualisation
- One-click deploy/stow position
- Adjustable grab force - pick up a sea urchin or cut a cable

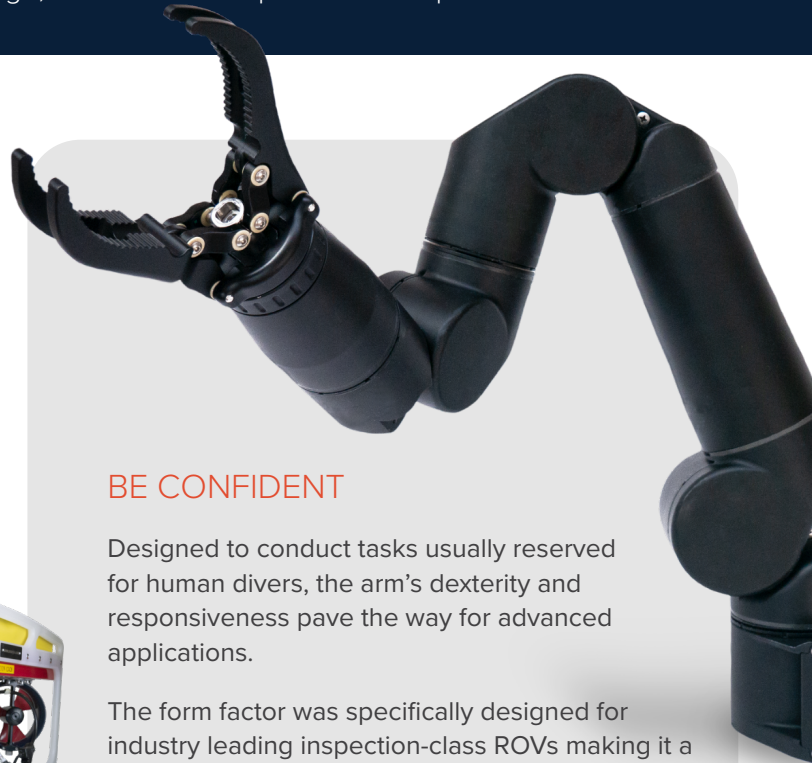

BE CONFIDENT

Designed to conduct tasks usually reserved for human divers, the arm's dexterity and responsiveness pave the way for advanced applications.

The form factor was specifically designed for industry leading inspection-class ROVs making it a ready-to-go option for existing fleets.

ELECTRICAL

Voltage	20-48V
Nominal Power	200W
Peak Power	300W
COMS	RS232/RS485/Ethernet

ENVIRONMENTAL

Depth	450MSW
Temp	0°C to 40°C
Material	AL7075 T6

MECHANICAL

Lift Capacity	10kg
Max Lift	20kg
Weight (Air)	9500g
Weight (Water)	4500g

Master Arm Controller Enabled

Note: Master Arm not included



Mission Specific End-Effectors | Interchange With Ease



RB-1025



RB-1055



RB-1041



RB-1043

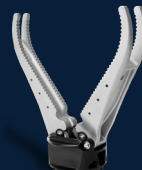

RB-1044 SS



RB-1042



RB-1034

SPECIFICATIONS

Reach	900mm
Full Reach Lift	10kg
Joint Speed	45°/s
Linear Force	10kN
End-effector Accuracy	<10mm
Grabber Close Force	80kg (800N)
Optional Sensor Interface	PWR + 485 + Ethernet
Control Modes	Position, Velocity, Cartesian (XYZ)

Power Interface

Bulkhead	MCBH4M – MC 4C Male
Pigtail	MCIL4F – MC Inline, 4C Female, 60cm

Comms Interface

Bulkhead	MCBH8ME – MC Ethernet, 8C Male
Pigtail	MC Ethernet Inline, 8C Female 100cm

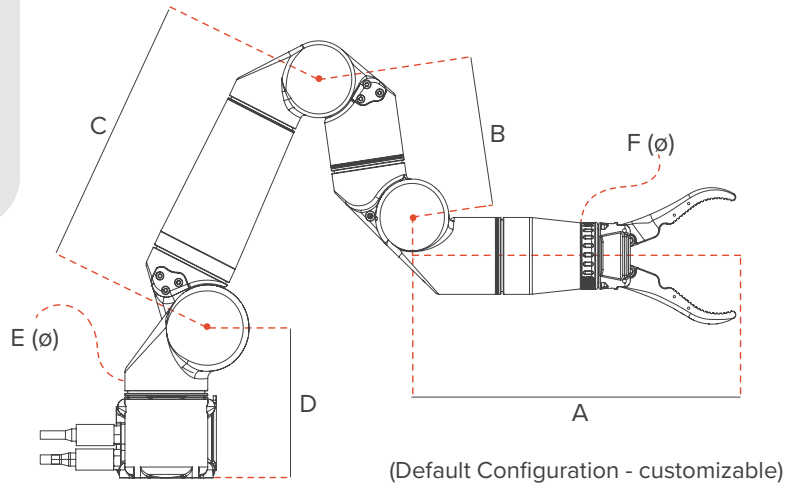
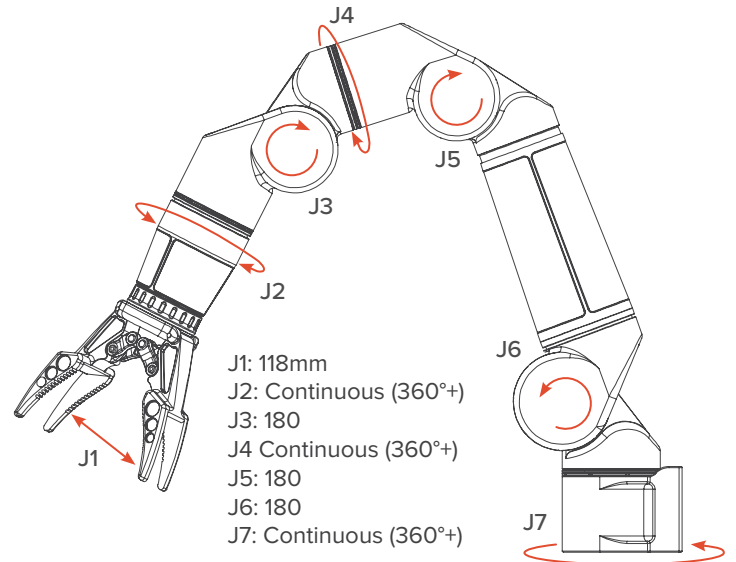

A: 365mm
 B: 160mm
 C: 292mm
 D: 159mm
 Max OD (E): 92mm
 Min OD (F): 82mm

HIGH MOBILITY & COMPACT

TOP VIEW

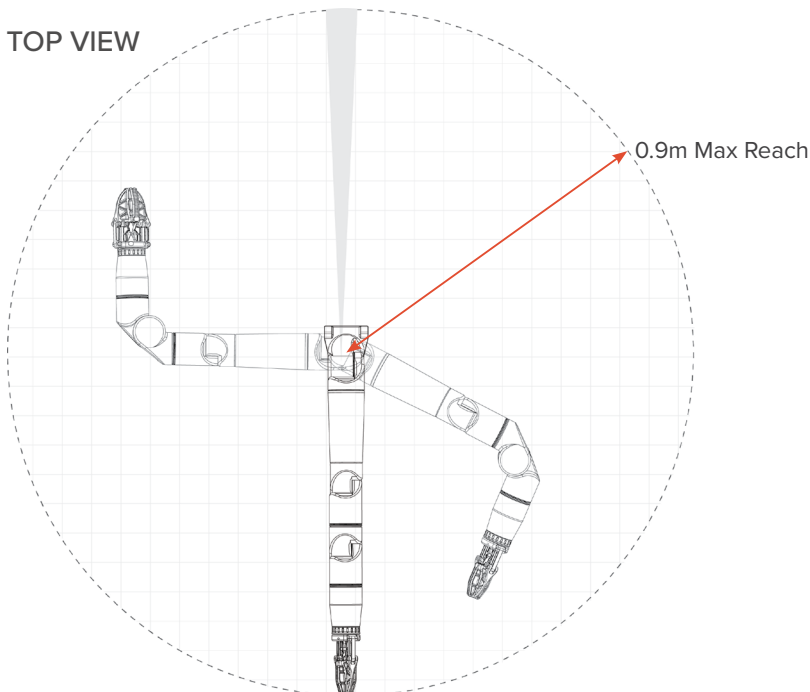

SIDE VIEW

