

4

3

2

1

REVISION HISTORY			
REV.	DESCRIPTION	DATE	DRAWN BY
1	ORIGINAL PRINT	7/2/2018	N. LAWRENCE
3	SEE am-3915_25_lhc AND am-3915_25_rhc	11/16/2018	N. LAWRENCE
3	SEE am-3915_25_lhc AND am-3915_25_rhc	11/26/2018	N. LAWRENCE

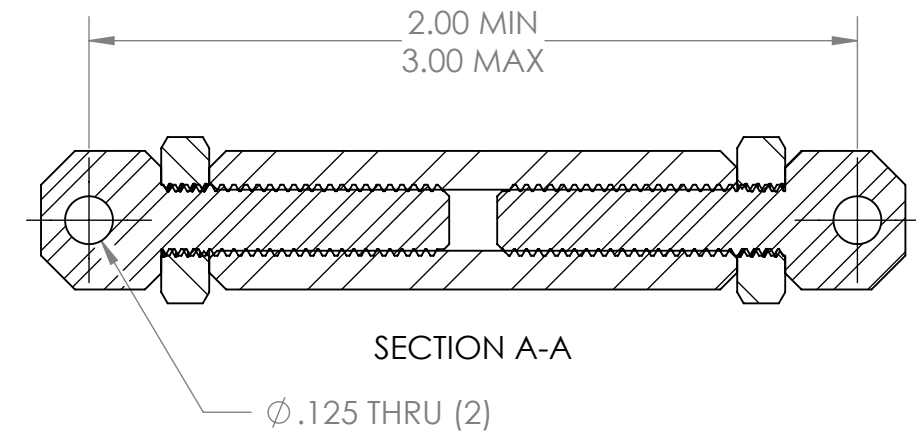
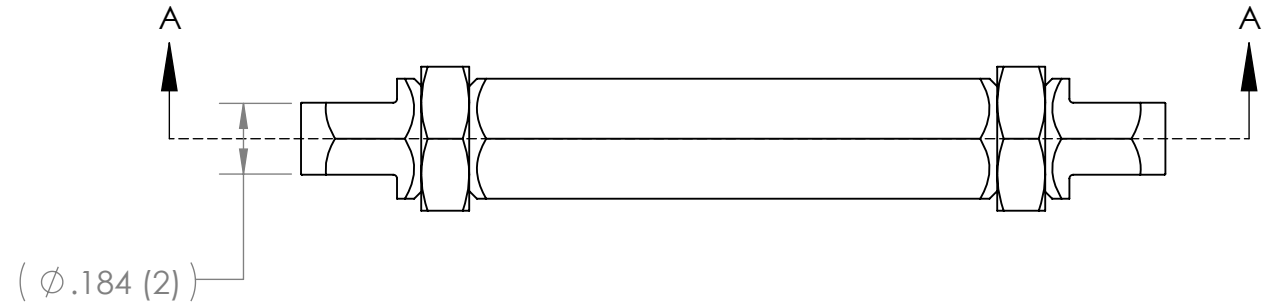
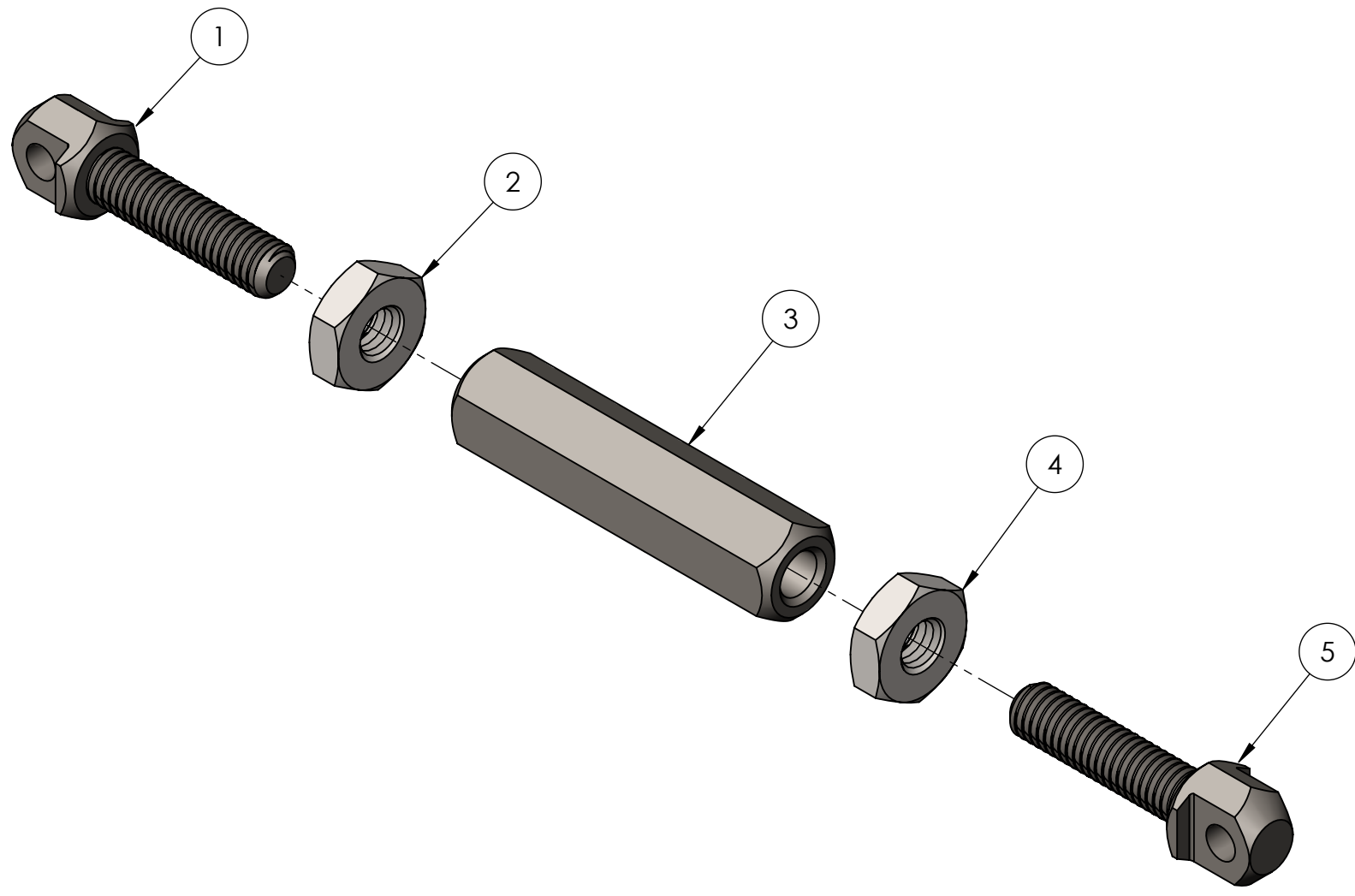

*** SEE CAD FOR ADDITIONAL TOOLPATH INFO***

BILL OF MATERIALS		
ITEM NO.	PART NUMBER	DESCRIPTION
1	am-3915_25_lhc	#25 CHAIN ATTACHMENT CLEVIS, LEFT HAND THREAD
2	am-3914_lhn	#10-32 NUT, LEFT HAND THREAD
3	am-3914_body	INLINE CHAIN TENSIONER BODY
4	am-3914_rhn	#10-32 NUT, RIGHT HAND THREAD
5	am-3915_25_rhc	#25 CHAIN ATTACHMENT CLEVIS, RIGHT HAND THREAD

UNLESS OTHERWISE SPECIFIED:	COMMENTS:
DIMENSIONS ARE IN INCHES	DUAL DIMENSIONS ARE IN MILLIMETERS.
TOLERANCES:	BREAK ALL SHARP EDGES.
FRACTIONAL	±1/16
ANGULAR: MACH	±1°
ANGULAR: BEND	±5°
ONE PLACE DECIMAL	±0.1
TWO PLACE DECIMAL	±0.01
THREE PLACE DECIMAL	±0.005
FOUR PLACE DECIMAL	±0.0005
MATERIAL	
FINISH	
DO NOT SCALE DRAWING	

AndyMark

TITLE: **#25 CHAIN
INLINE TENSIONER**

SIZE	DWG. NO.	REV
B	am-3915_25	3

SCALE: 2:1 SHEET 1 OF 6

4

3

2

1

REVISIONS			
REV.	DESCRIPTION	DATE	DRAWN
1	ORIGINAL PRINT	7/2/2018	N. LAWRENCE
2	INCREASED HOLE DIAMETER, CHANGED HOLE POSITION, SHORTENED CLEVIS	11/16/2018	N. LAWRENCE
3	RETURNED CLEVIS TO ORIGINAL SIZE, INCREASED HOLE DIA.	11/26/2018	N. LAWRENCE

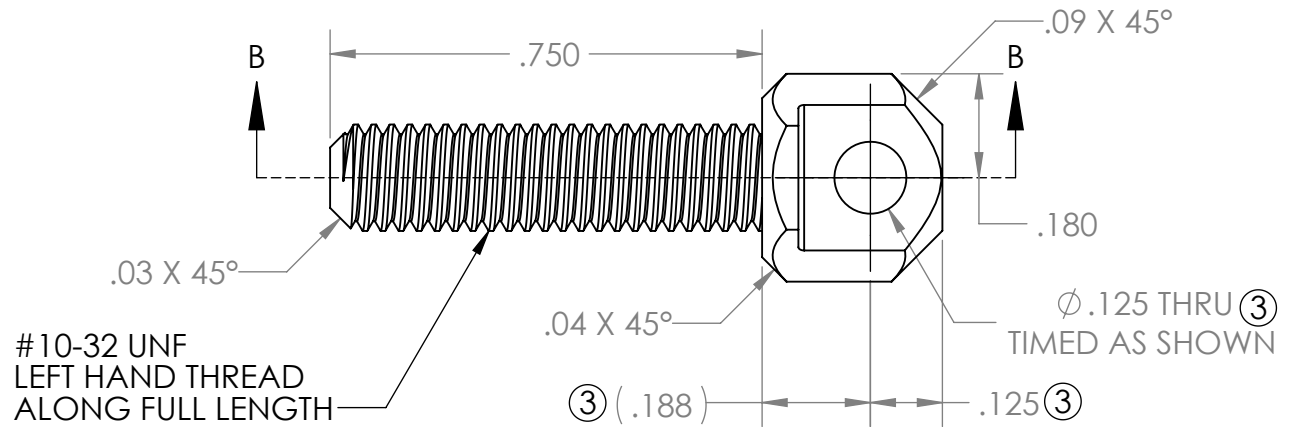
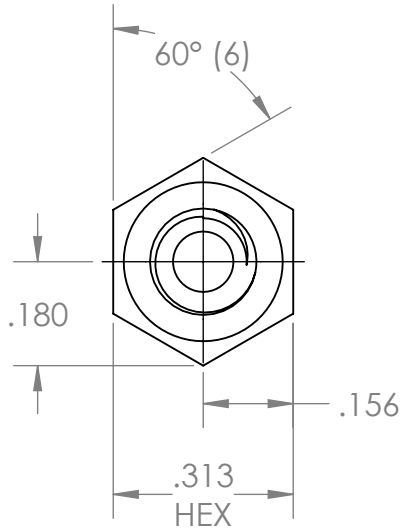

#10-32 UNF
LEFT HAND THREAD
ALONG FULL LENGTH

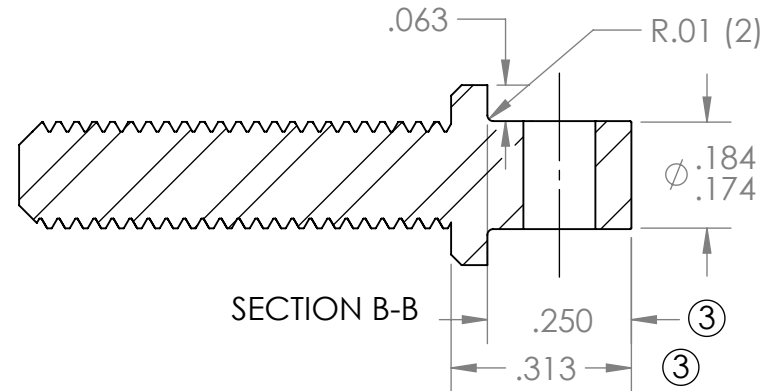

*** SEE CAD FOR ADDITIONAL TOOLPATH INFO***

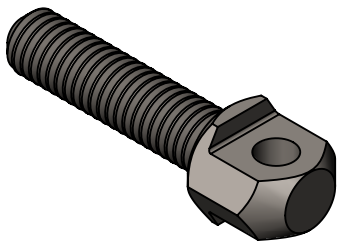

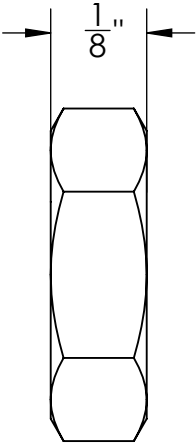
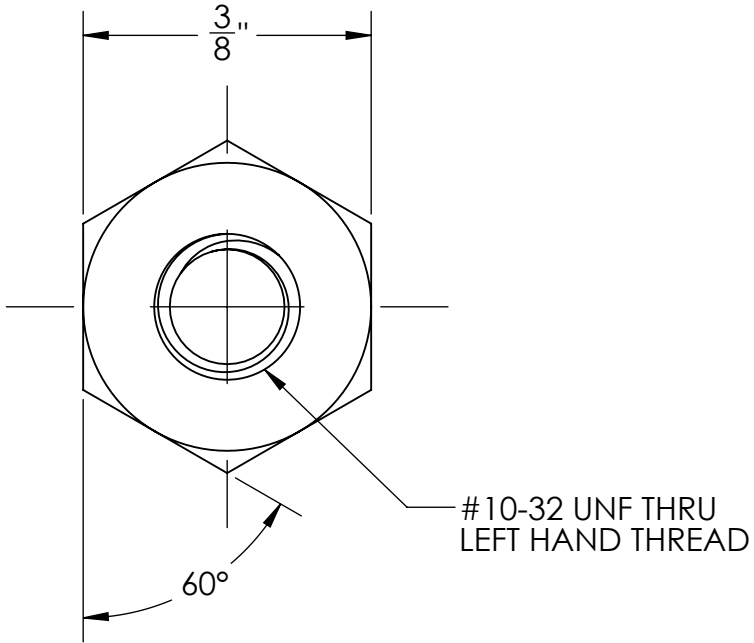

UNLESS OTHERWISE SPECIFIED:		COMMENTS:				
DIMENSIONS ARE IN INCHES		DUAL DIMENSIONS ARE IN MILLIMETERS.				
TOLERANCES: FRACTIONAL ±1/16 ANGULAR: MACH ±1° ANGULAR: BEND ±5° ONE PLACE DECIMAL ±0.1 TWO PLACE DECIMAL ±0.01 THREE PLACE DECIMAL ±0.005 FOUR PLACE DECIMAL ±0.0005		BREAK ALL SHARP EDGES		TITLE: 25 CHAIN ATTACHMENT CLEVIS LEFT HAND THREAD		
MATERIAL 1045 CRS		NAME KK	DATE 7/2/18	SIZE A	DWG. NO. am-3915_25_lhc	REV 3
FINISH ZINC PLATED		ENG APPR.	MFG APPR.	SCALE: 3:1 WEIGHT:		SHEET 2 OF 6
DO NOT SCALE DRAWING		Q.A.				

REVISIONS			
REV.	DESCRIPTION	DATE	DRAWN
1	ORIGINAL PRINT	6/18/2018	N. LAWRENCE

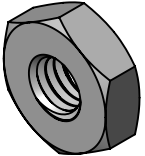

*** SEE CAD FOR ADDITIONAL TOOLPATH INFO***



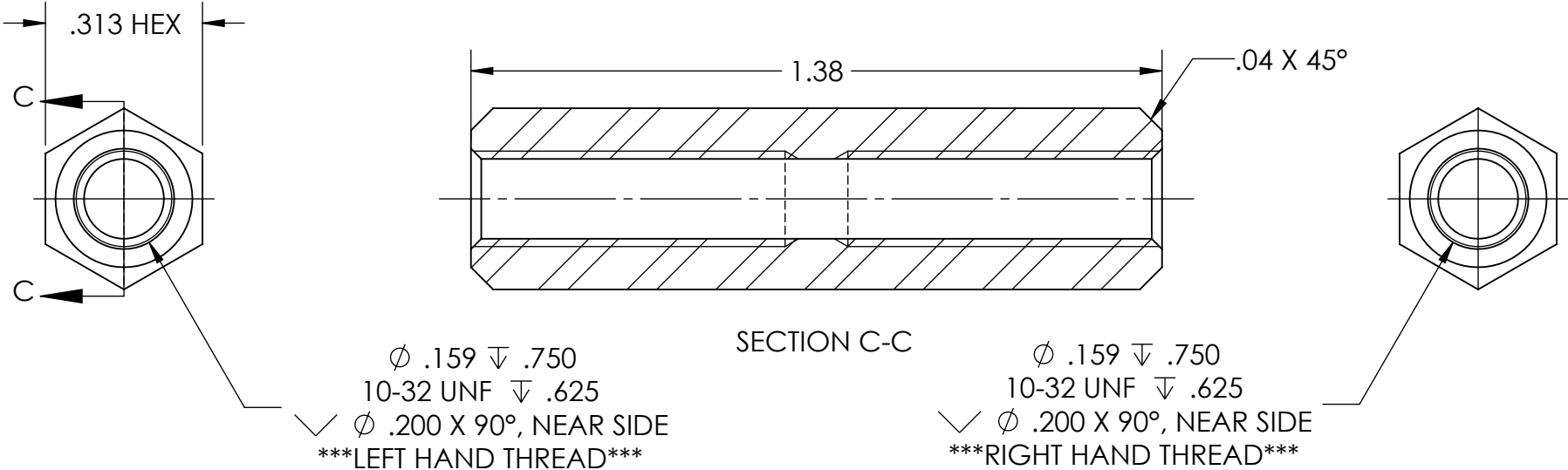

UNLESS OTHERWISE SPECIFIED:		COMMENTS:					
DIMENSIONS ARE IN INCHES		DUAL DIMENSIONS ARE IN MILLIMETERS.					
TOLERANCES: FRACTIONAL ±1/16 ANGULAR: MACH ±1° ANGULAR: BEND ±5° ONE PLACE DECIMAL ±0.1 TWO PLACE DECIMAL ±0.01 THREE PLACE DECIMAL ±0.0005 FOUR PLACE DECIMAL ±0.0005		BREAK ALL SHARP EDGES		TITLE: 10-32 LEFT HAND THREAD NUT			
MATERIAL 1018 CRS		CHECKED	NAME KK	DATE 7/2/18	SIZE A	DWG. NO. am-3914_lhn	REV 3
FINISH ZINC PLATED		MFG APPR.		SCALE: 4:1		WEIGHT:	SHEET 3 OF 6
DO NOT SCALE DRAWING		Q.A.					

REVISIONS			
REV.	DESCRIPTION	DATE	DRAWN
1	ORIGINAL PRINT	6/18/2018	N. LAWRENCE

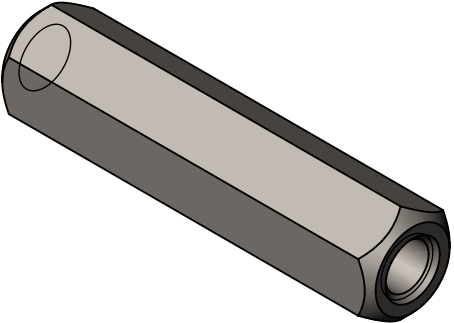

*** SEE CAD FOR ADDITIONAL TOOLPATH INFO***



UNLESS OTHERWISE SPECIFIED:		COMMENTS:			
DIMENSIONS ARE IN INCHES		DUAL DIMENSIONS ARE IN MILLIMETERS.			
TOLERANCES:		BREAK ALL SHARP EDGES		TITLE:	
FRACTIONAL	±1/16			INLINE CHAIN TENSIONER BODY	
ANGULAR: MACH	±1°			SIZE	
ANGULAR: BEND	±5°			DWG. NO.	
ONE PLACE DECIMAL	±0.1			am-3914_body	
TWO PLACE DECIMAL	±0.01			REV	
THREE PLACE DECIMAL	±0.005			3	
FOUR PLACE DECIMAL	±0.0005			SCALE: 3:1	
MATERIAL	1045 CRS	CHECKED	NAME	DATE	WEIGHT:
FINISH	ZINC PLATED	ENG APPR.	KK	7/2/18	SHEET 4 OF 6
DO NOT SCALE DRAWING		MFG APPR.			
		Q.A.			

REVISIONS			
REV.	DESCRIPTION	DATE	DRAWN
1	ORIGINAL PRINT	6/18/2018	N. LAWRENCE

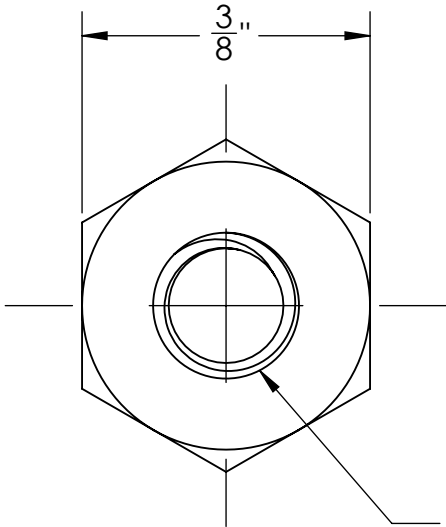

#10-32 UNF THRU
RIGHT HAND THREAD

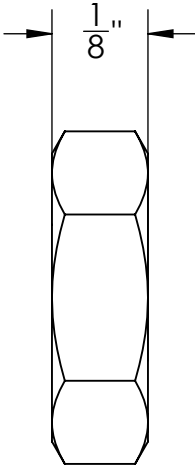

*** SEE CAD FOR ADDITIONAL TOOLPATH INFO***

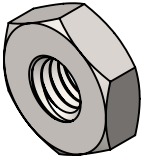

UNLESS OTHERWISE SPECIFIED:		COMMENTS:				
DIMENSIONS ARE IN INCHES		DUAL DIMENSIONS ARE IN MILLIMETERS.				
TOLERANCES: FRACTIONAL ±1/16 ANGULAR: MACH ±1° ANGULAR: BEND ±5° ONE PLACE DECIMAL ±0.1 TWO PLACE DECIMAL ±0.01 THREE PLACE DECIMAL ±0.005 FOUR PLACE DECIMAL ±0.0005		BREAK ALL SHARP EDGES		TITLE: 10-32 RIGHT HAND THREAD NUT		
MATERIAL 1018 CRS		NAME	DATE	SIZE	DWG. NO.	REV
FINISH ZINC PLATED		CHECKED	7/2/18	A	am-3914_rhn	3
DO NOT SCALE DRAWING		ENG APPR.		SCALE: 4:1		WEIGHT:
		MFG APPR.		SHEET 5 OF 6		
		Q.A.				

REVISIONS			
REV.	DESCRIPTION	DATE	DRAWN
1	ORIGINAL PRINT	7/2/2018	N. LAWRENCE
2	INCREASED HOLE DIAMETER, CHANGED HOLE POSITION, SHORTENED CLEVIS	11/16/2018	N. LAWRENCE
3	RETURNED CLEVIS TO ORIGINAL SIZE, INCREASED HOLE DIA.	11/26/2018	N. LAWRENCE

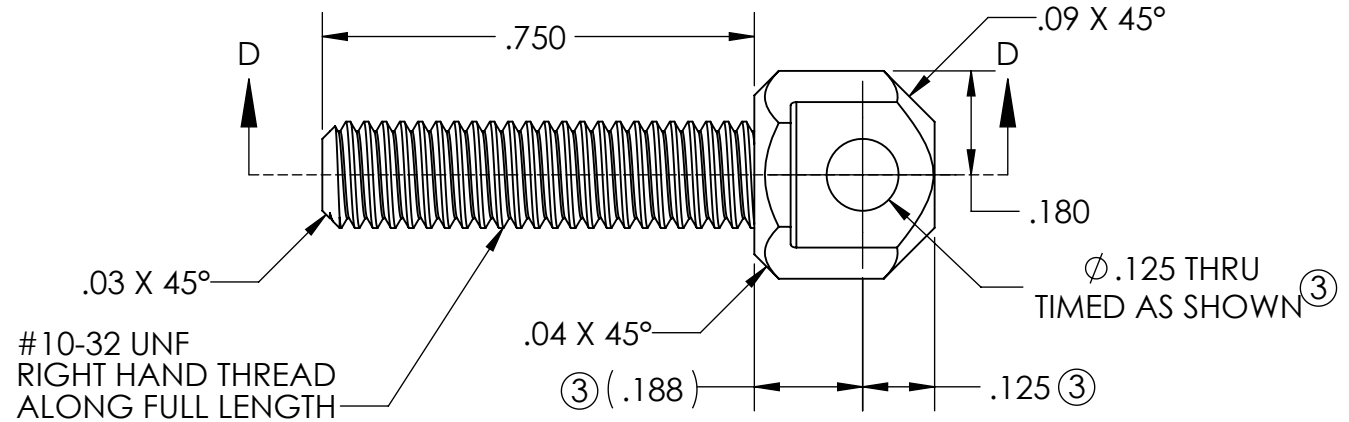
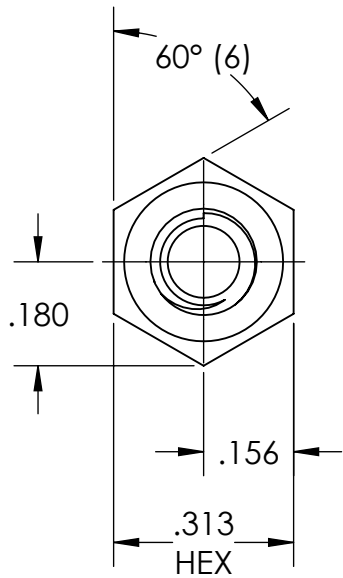

#10-32 UNF
RIGHT HAND THREAD
ALONG FULL LENGTH

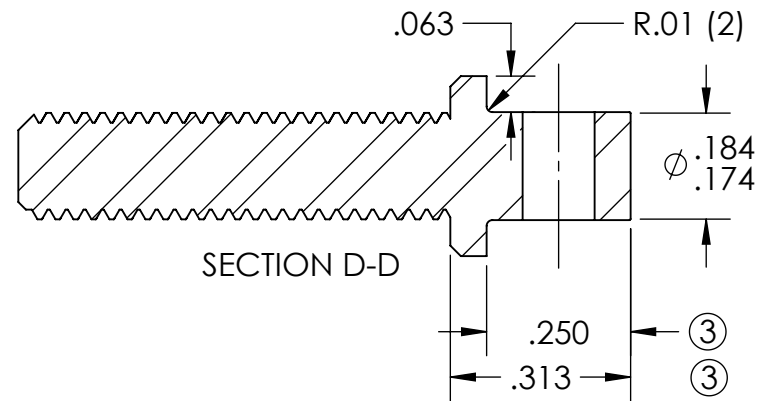

*** SEE CAD FOR ADDITIONAL TOOLPATH INFO***

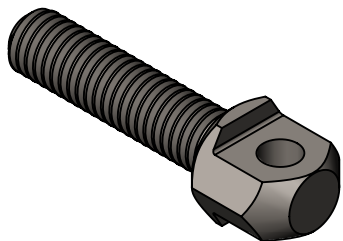

UNLESS OTHERWISE SPECIFIED:		COMMENTS:			
DIMENSIONS ARE IN INCHES		DUAL DIMENSIONS ARE IN MILLIMETERS.			
TOLERANCES:		BREAK ALL SHARP EDGES		TITLE:	
FRACTIONAL	±1/16			25 CHAIN ATTACHMENT CLEVIS	
ANGULAR: MACH	±1°			RIGHT HAND THREAD	
ANGULAR: BEND	±5°			SIZE	
ONE PLACE DECIMAL	±0.1			DWG. NO.	
TWO PLACE DECIMAL	±0.01			A am-3915_25_rhc	
THREE PLACE DECIMAL	±0.005			REV	
FOUR PLACE DECIMAL	±0.0005			3	
MATERIAL	1045 CRS	NAME	DATE	SCALE: 3:1	
FINISH	ZINC PLATED	CHECKED	KK 7/2/18	WEIGHT:	
DO NOT SCALE DRAWING		ENG APPR.		SHEET 6 OF 6	
		MFG APPR.			
		Q.A.			