

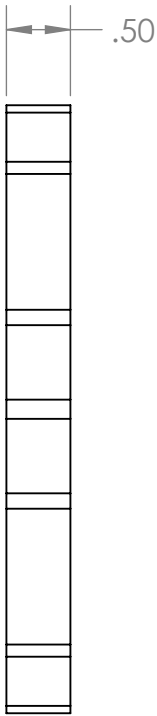

REVISION HISTORY			
REV.	DESCRIPTION	DATE	DRAWN BY
1	ORIGINAL PRINT	2/17/2021	N. LAWRENCE
2	UPDATED PART NUMBER FOR PRODUCTION	4/1/2021	N. LAWRENCE

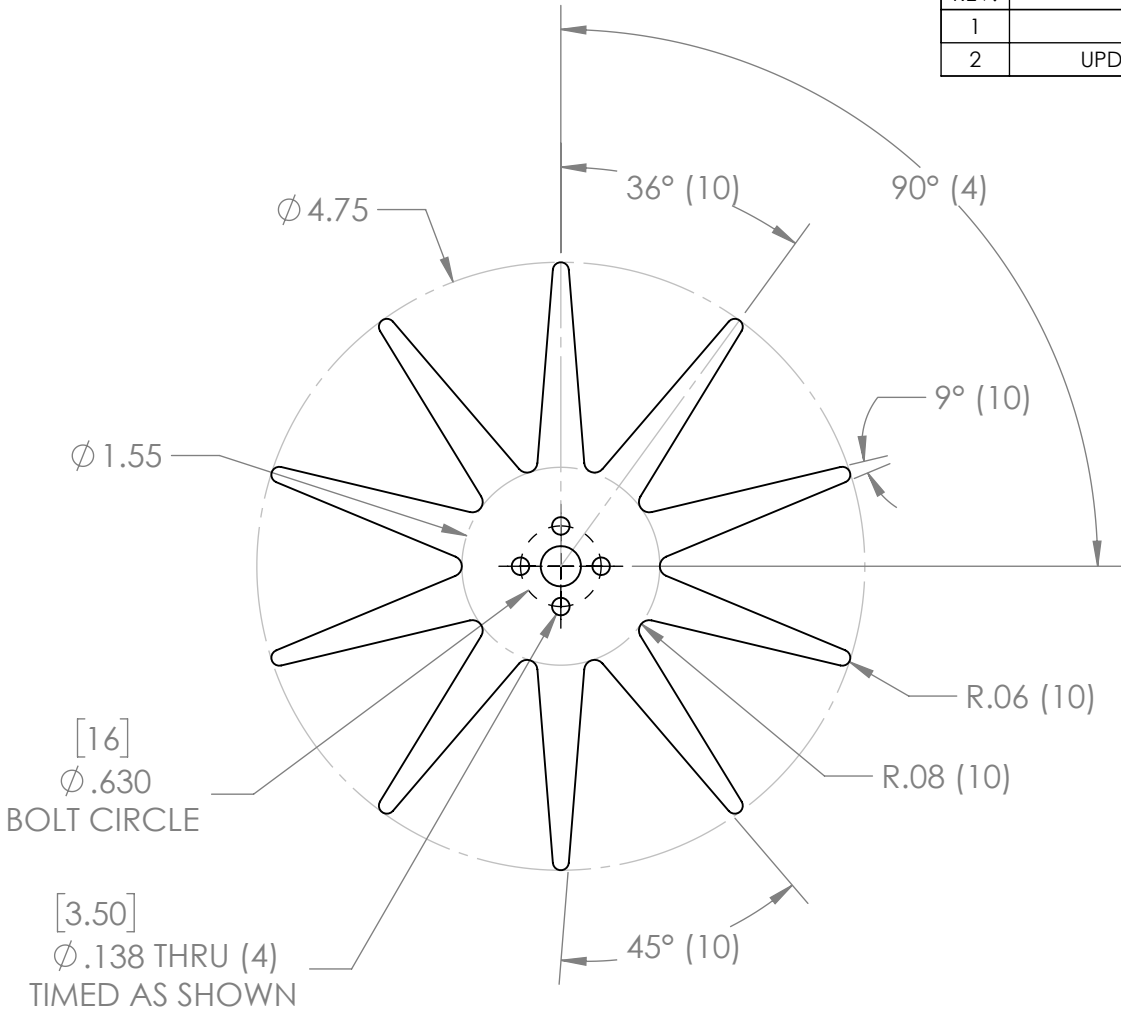

*** SEE CAD FOR ADDITIONAL TOOLPATH INFO***

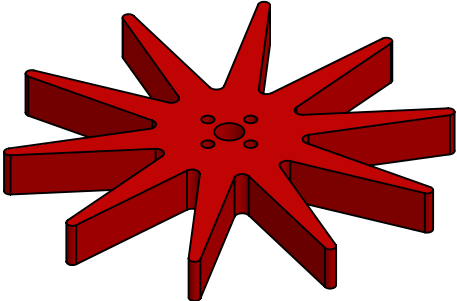

UNLESS OTHERWISE SPECIFIED:		COMMENTS:				
DIMENSIONS ARE IN INCHES		DUAL DIMENSIONS ARE IN MILLIMETERS.				
TOLERANCES:		BREAK ALL SHARP EDGES.		TITLE:		
FRACTIONAL	±1/16			ENTRAPPTION STAR		
ANGULAR: MACH	±1°			8mm BORE		
ANGULAR: BEND	±5°			SIZE	DWG. NO.	REV
ONE PLACE DECIMAL	±0.1			A	am-4577	2
TWO PLACE DECIMAL	±0.01			SCALE: 1:1.5		
THREE PLACE DECIMAL	±0.005			SHEET 1 OF 1		
FOUR PLACE DECIMAL	±0.0005					
MATERIAL	45A RED SILICONE	CHECKED	NAME	DATE		
FINISH	DEBURRED	ENG APPR.	NM	2/22/21		
DO NOT SCALE DRAWING		MFG APPR.				
		Q.A.				